

All knockouts are actual size / Les disques défonçables sont grandeur réel
 All dimensions are before paint / Toutes les dimensions sont avant peinture

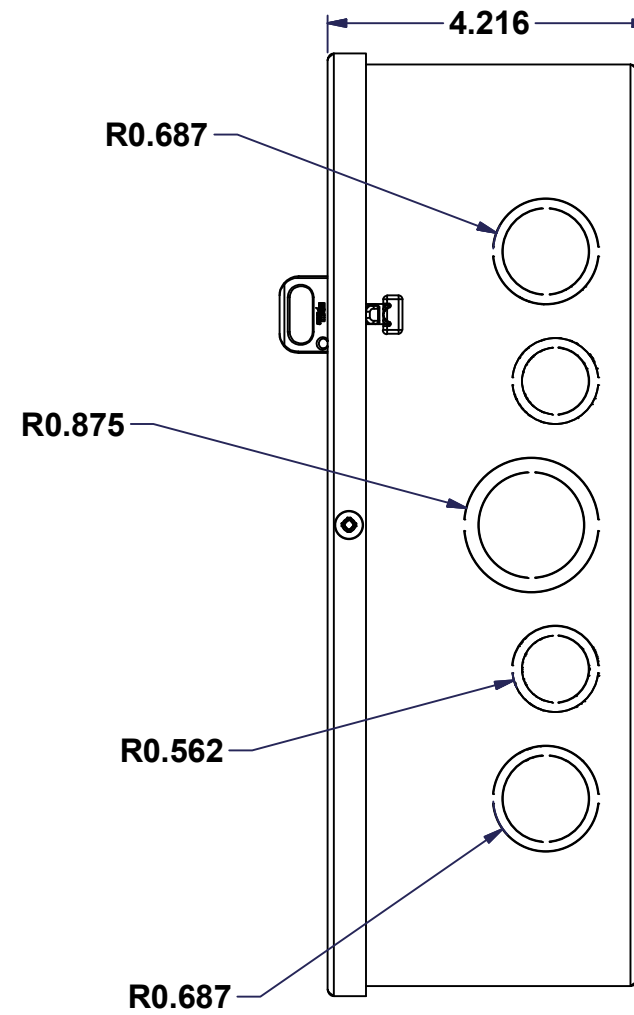

No.	Revisions	Date	By/Par
1	Add laser cut on ground bend, KO was 0.625" to back and 125AMP use STK-Q-67220	10/12/2012	AllenL
1.1	Change insulator grooves distance to 16mm on 1100B73 and 1100B74	28/3/2013	AllenL

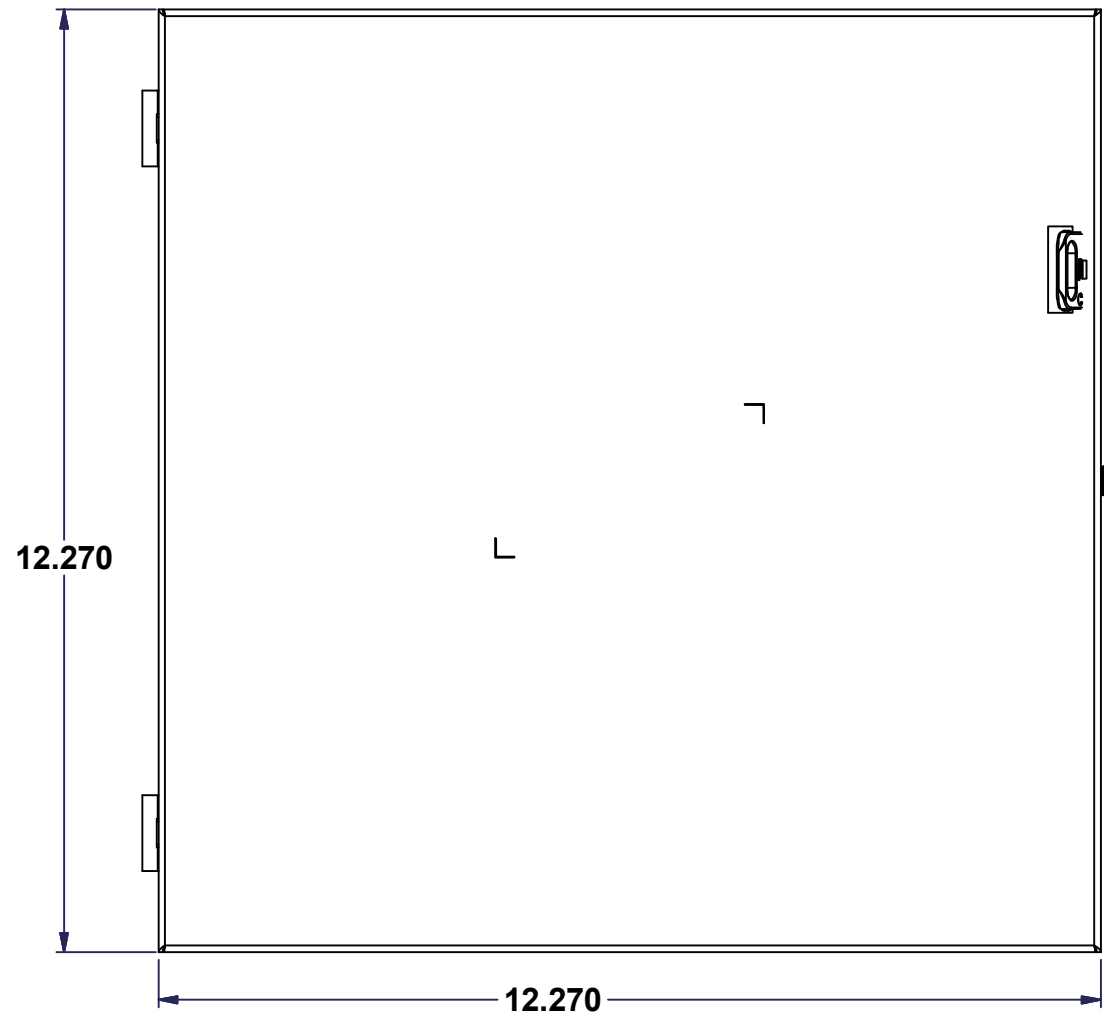
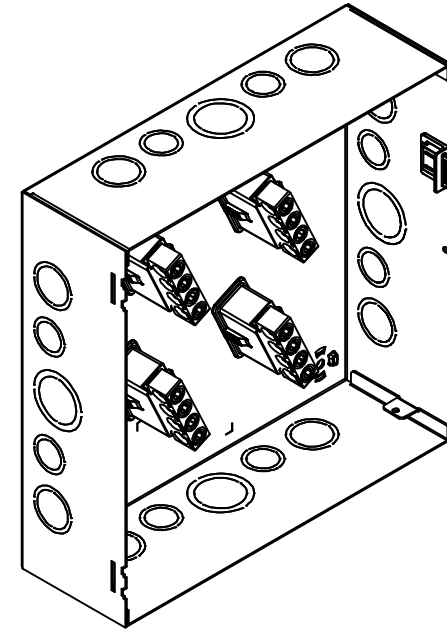
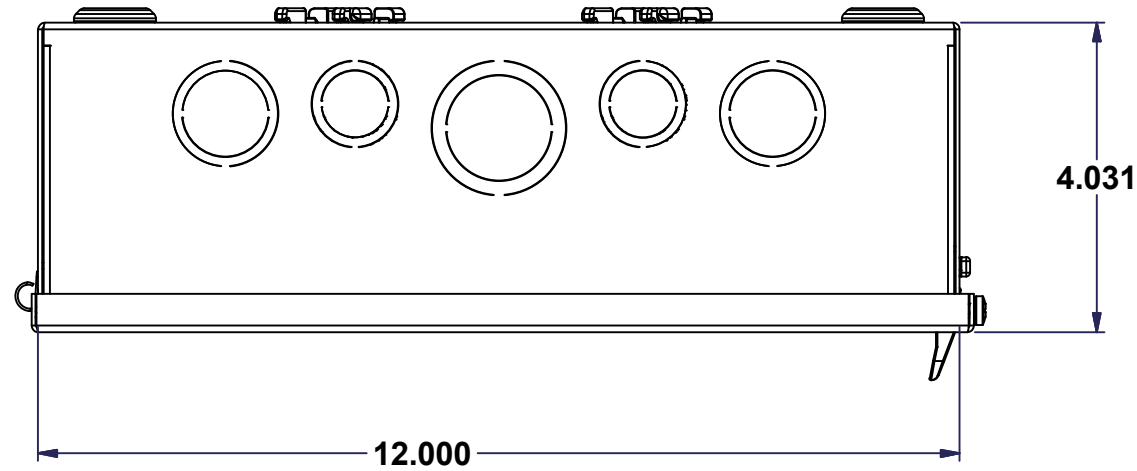
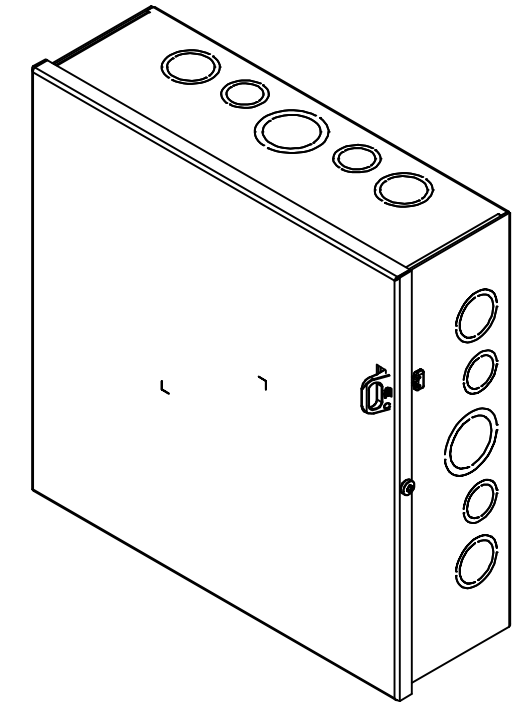

Isometric View

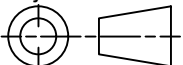

Ce dessin est confidentiel et ne doit pas être reproduit ou utilisé sans le consentement de EXM

 Tél: (450) 979-4373 Fax: (450) 979-4626 www.exmweb.com		Flatness Aplatissement Max 3.0mm Projection 
Customer Client	EXM Manufacturin	Date
Drawn By / Dessiné Par	MichaelA	Date 28-Jan-15
Material / Matière	See Part List	
Color / Couleur	See Part List	Finish / Fini See Part List
Description		Detail Rev.
1100B104 12" x 12" x 4" - 4 Wire Assembly		
Part Number / Numéro Pièce	Rev.	
1100B104	1	1 / 3

This drawing is confidential and must not be reproduced or used without the consent of EXM

This drawing is confidential and must not be reproduced or used without the consent of EXM

All knockouts are actual size / Les disques défonçables sont grandeur réel
 All dimensions are before paint / Toutes les dimensions sont avant peinture

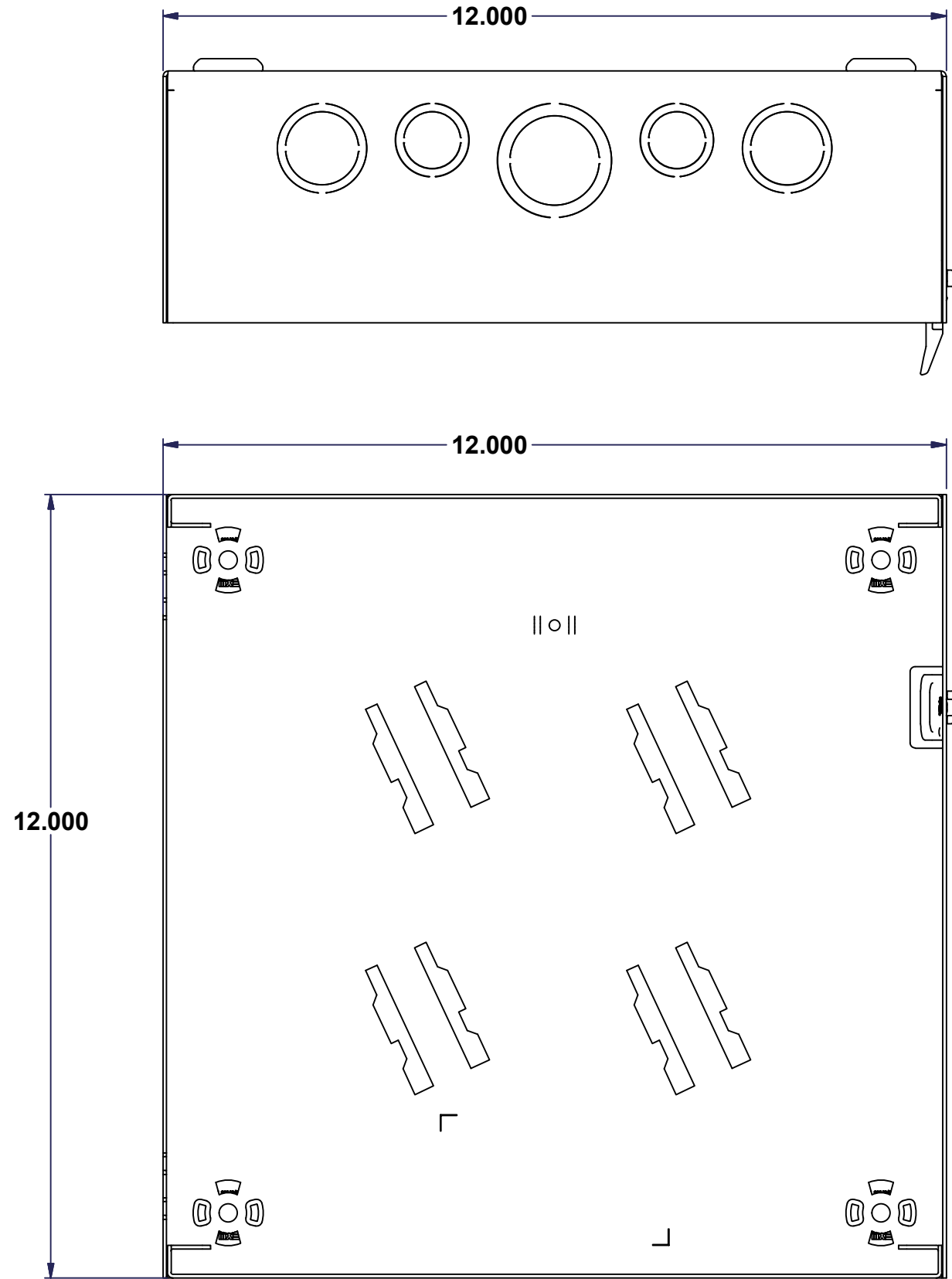

No.	Revisions	Date	By/Par
1	Add laser cut on ground bend, KO was 0.625" to back and 125AMP use STK-Q-67220	10/12/2012	AllenL
1.1	Change insulator grooves distance to 16mm on 1100B73 and 1100B74	28/3/2013	AllenL

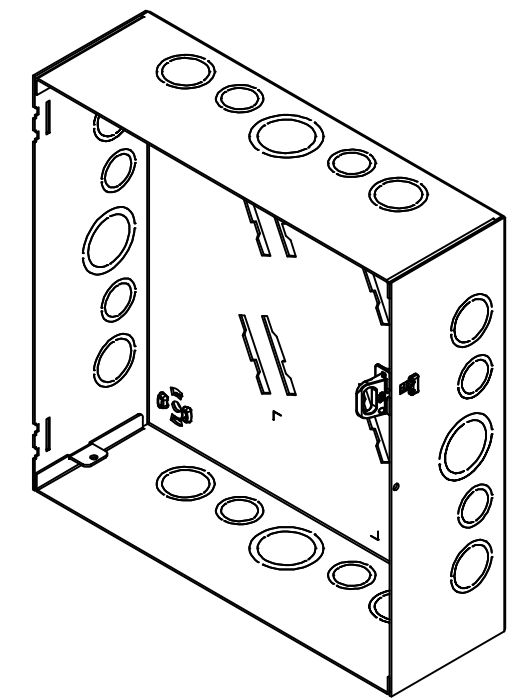

Isometric View

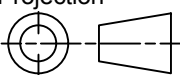

Ce dessin est confidentiel et ne doit pas être reproduit ou utilisé sans le consentement de EXM

 Tél: (450) 979-4373 Fax: (450) 979-4626 www.exmweb.com		Flatness Aplatissement Max 3.0mm Projection 
Customer Client	EXM Manufacturin	Date
Drawn By / Dessiné Par	MichaelA	Date 28-Jan-15
Material Matière	See Part List	
Color Couleur	See Part List	Finish Fini See Part List
Description		Detail Rev.
1100B 12" x 12" x 4" 4 Wire - Body		
Part Number / Numéro Pièce	Rev.	
1100B104B	1	2 / 3

This drawing is confidential and must not be reproduced or used without the consent of EXM

All knockouts are actual size / Les disques défonçables sont grandeur réel
 All dimensions are before paint / Toutes les dimensions sont avant peinture

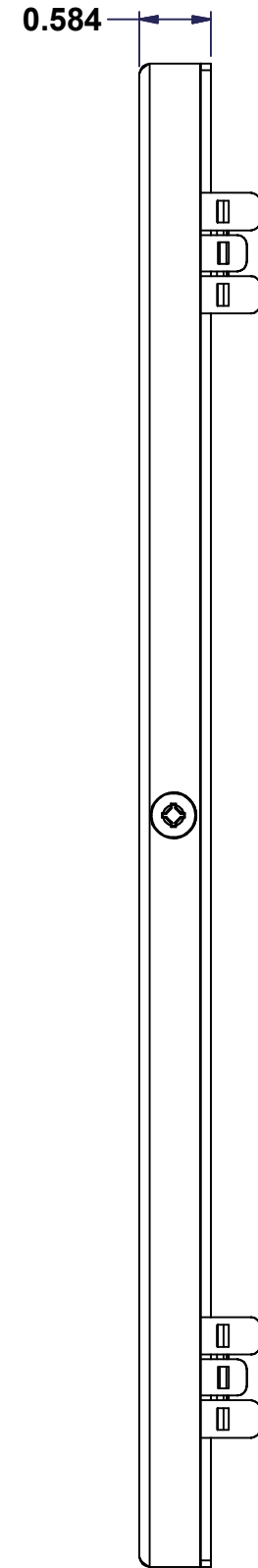
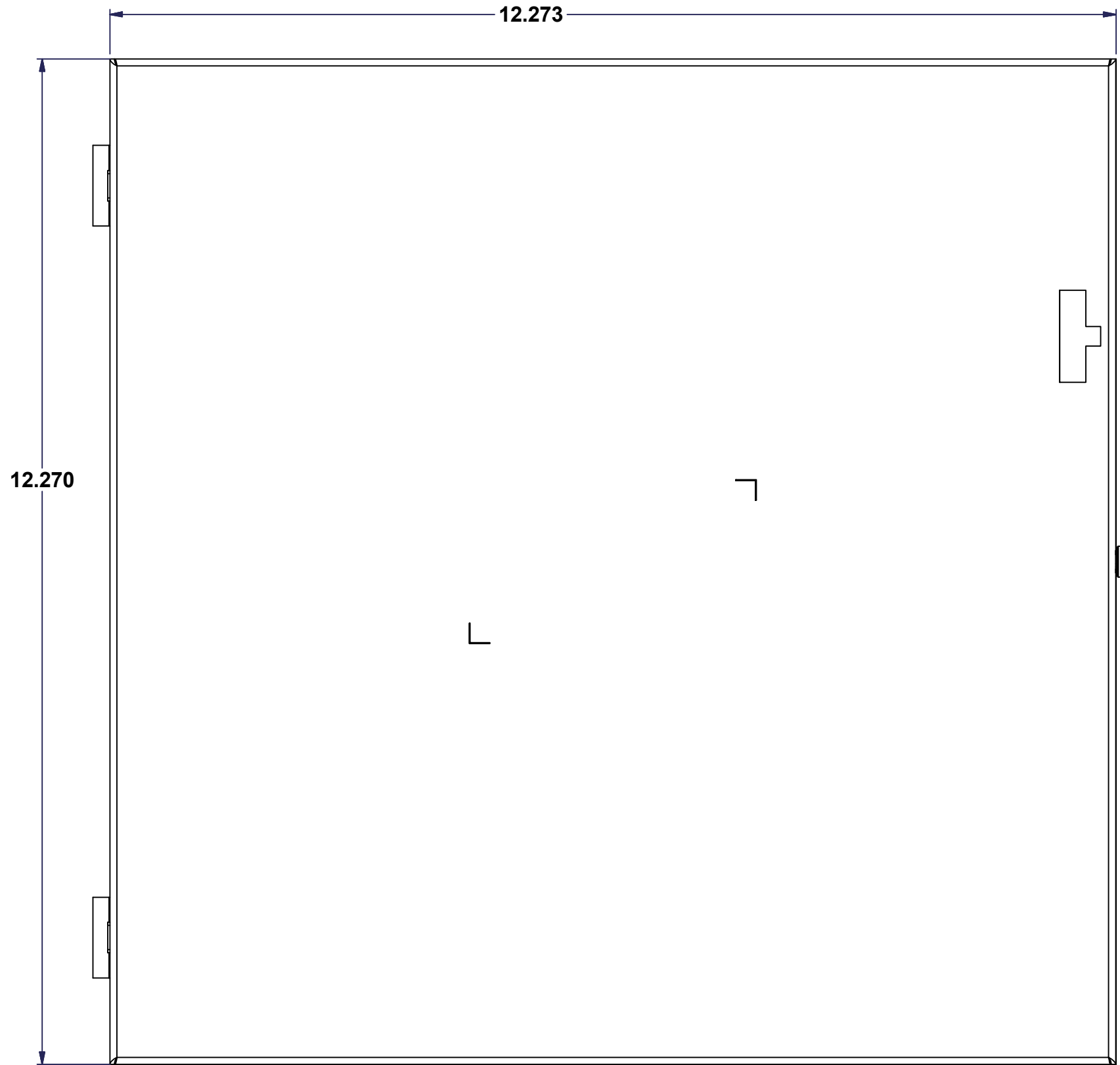

No.	Revisions	Date	By/Par
1	Revision Update As Body	10/12/2012	AllenL
1.1	Revision update as body part	28/3/2013	AllenL

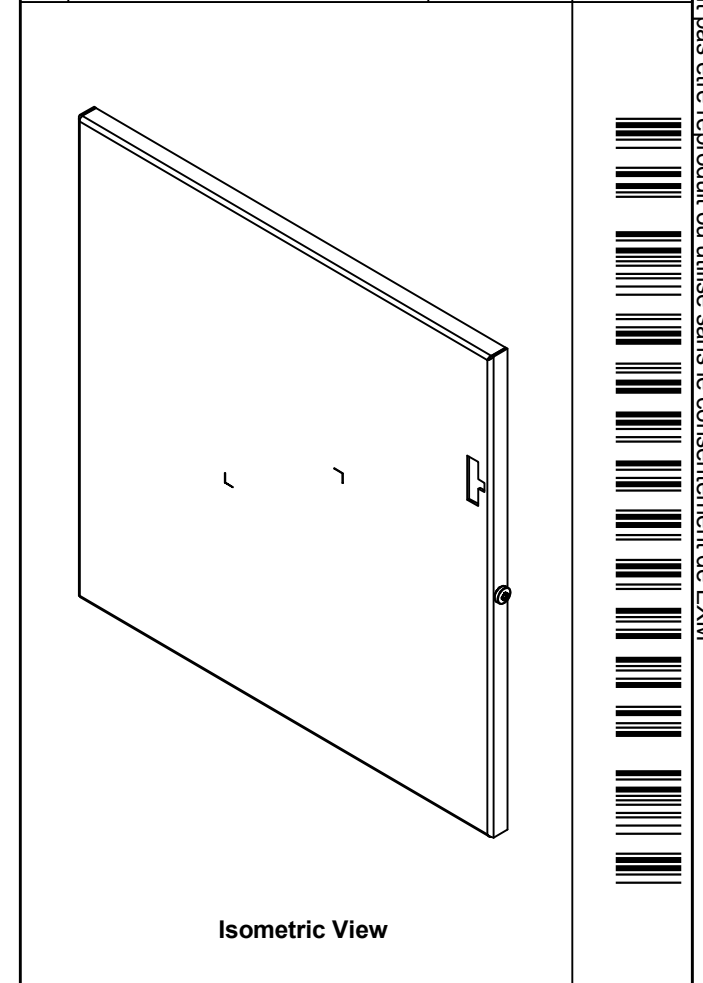

Ce dessin est confidentiel et ne doit pas être reproduit ou utilisé sans le consentement de EXM

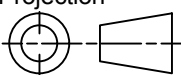
 Tél: (450) 979-4373 Fax: (450) 979-4626 www.exmweb.com		Flatness Aplatissement Max 3.0mm Projection 
Customer Client	EXM Manufacturin	Date
Drawn By / Dessiné Par	MichaelA	Date 28-Jan-15
Material Matière	See Part List	
Color Couleur	See Part List	Finish Fini See Part List
Description	Detail Rev.	
1100B 10" x 10" - Cover		
Part Number / Numéro Pièce	Rev.	3
1100B73C	1	3