

This drawing is confidential and must not be reproduced or used without the consent of EXM

Ce dessin est confidentiel et ne doit pas être reproduit ou utilisé sans le consentement de EXM

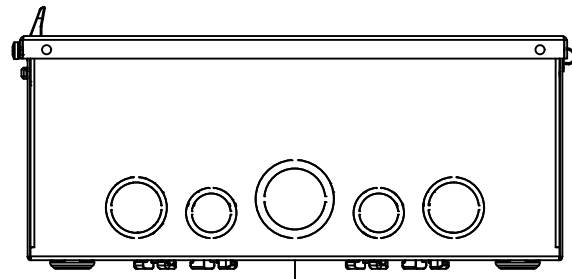

TOP

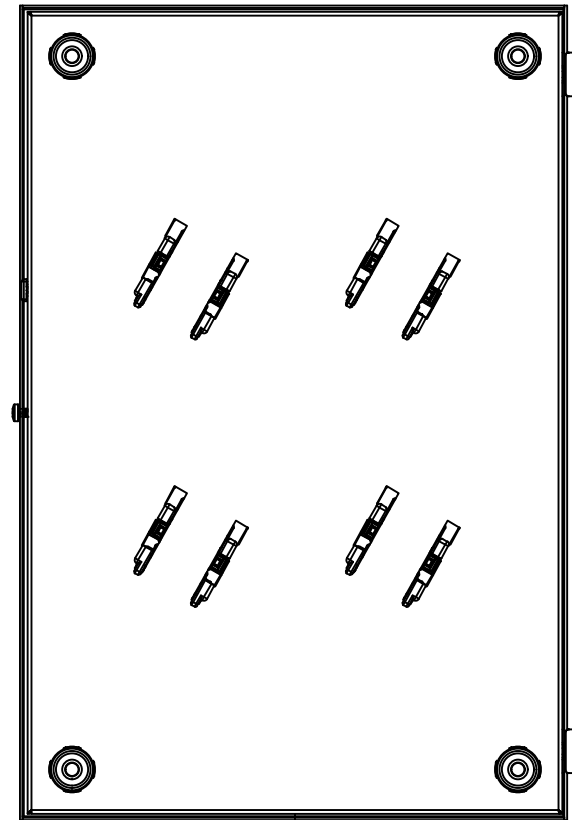

BACK

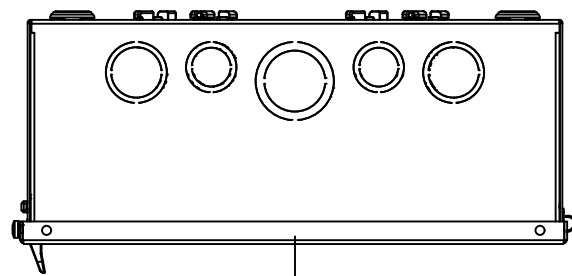

BOTTOM

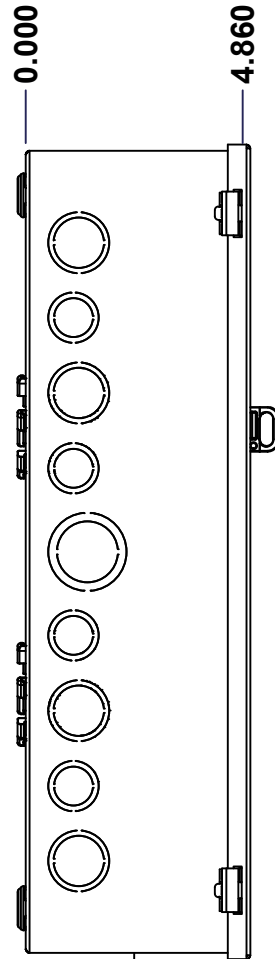

LEFT

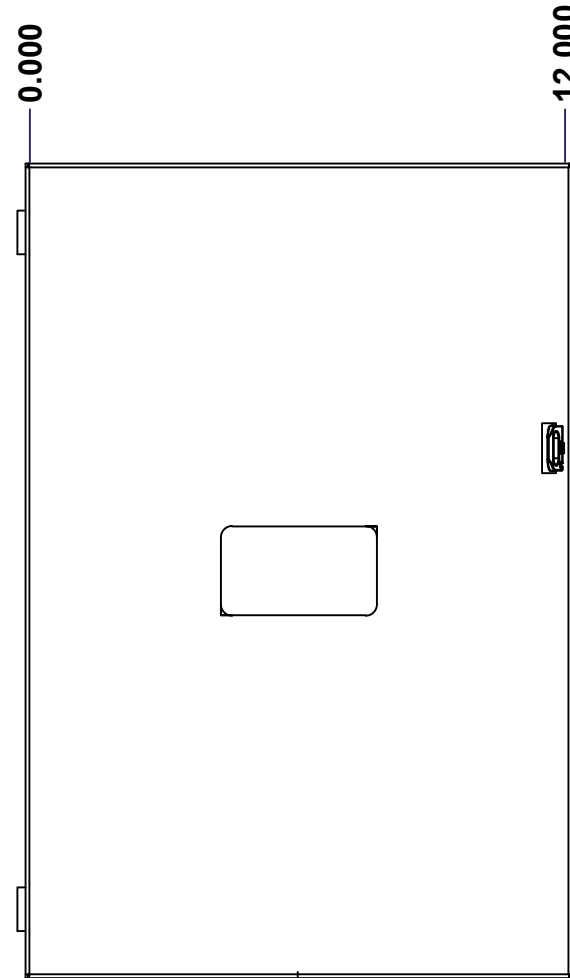

FRONT

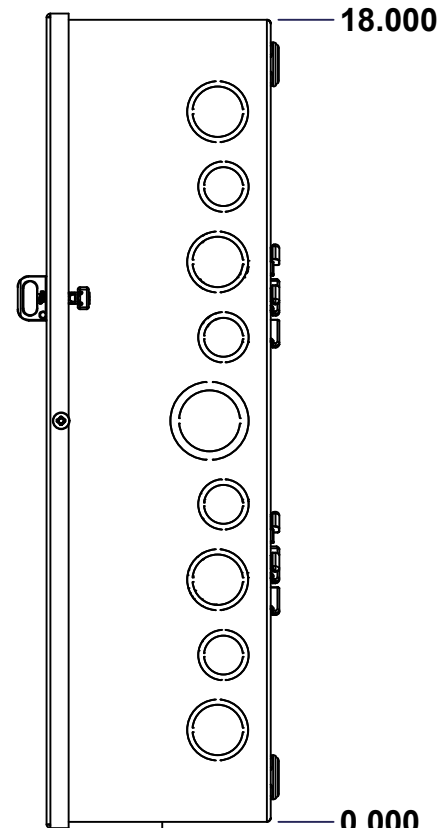

RIGHT

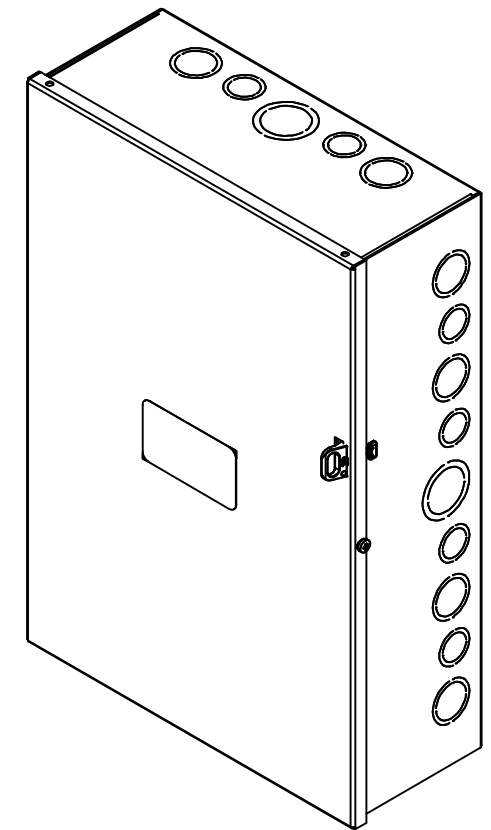

Isometric View

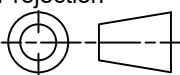

No.	Revisions	Date	By/Par

 Tél: (450) 979-4373 Fax: (450) 979-4626 <a href="http://www.exmweb.com">www.exmweb.com</a>		Flatness Aplatissement Max 3.0mm Projection 
Customer Client	Date	
Drawn By Dessiné Par	BoxCad: BoxCad	Date 27-Jan-25
Material Matière	16 Ga Cold Rolled A1008 CS Type B (1.4mm)	
Color Couleur	Asa-61 Grey	Finish Fini Smooth
Description	Detail Rev.	
1100B 18" x 12" x 4.86" Assembly		
Part Number Numéro Pièce	Rev. 0	1 / 10

SEE BILL OF MATERIAL ON LAST PAGE

**1100B204**

This drawing is confidential and must not be reproduced or used without the consent of EXM

Ce dessin est confidentiel et ne doit pas être reproduit ou utilisé sans le consentement de EXM

NOTE	
ITEM	DESCRIPTION
1	NEMA 1 Enclosure (IP20)
2	C/W Standard ground studs on box and cover
3	W/O Inner panel
4	W/O Inner panel mounting studs

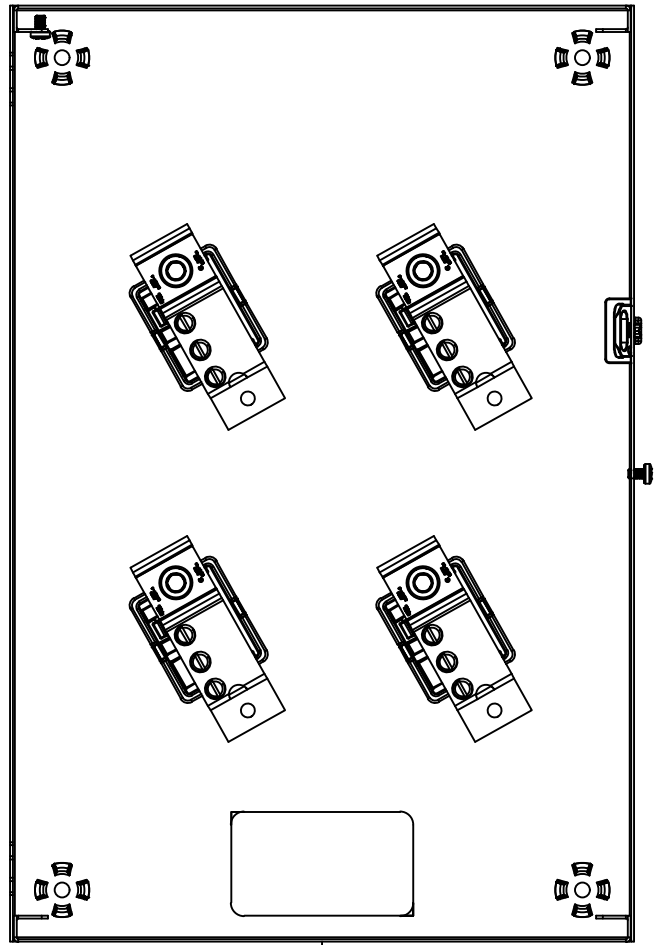

FRONT

No.	Revisions	Date	By/Par

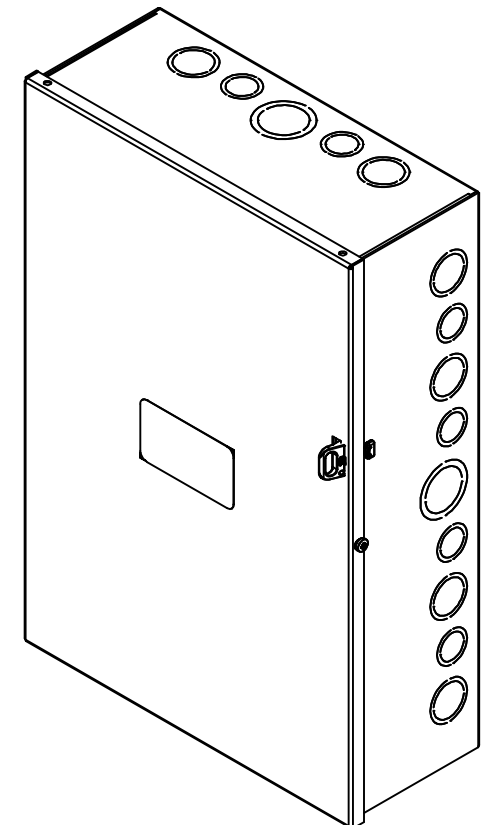

Isometric View



PACKING		
ITEM	QTY	DESCRIPTION
Cardboard sleeve	2	Top and Bottom
Cardboard strip	2	Between back of enclosure and inner panel
Plastic bag	1	To protect cover surface and inside gasket
Cardboard corner	4	To reinforced for the plastic strap tightening
Plastic strap - Black	2	To Squeeze the 2 cardboard sleeve together
Packaging label	3	White label with PN
Plastic strap- Green	2	To secure the enclosure to the wood pallet
Wood Pallet	1	2" deeper and 3" larger than enclosure size

Qty	Part Number	Rev	Description
1	STK-Q-77450	3	Plastic Padlock Provision
1	1100B204C	0	1100B 18" x 12" Cover
1	STK-K-02700	0	1412 T Accessory Kit
1	1100B204B	0	1100B 18" x 12" x 4.86" Body
4	881 BRB225	0	Aluminum Lug with Insulator

Parts List

Tél: (450) 979-4373  
Fax: (450) 979-4626  
[www.exmweb.com](http://www.exmweb.com)

Flatness  
Aplatissement  
Max 3.0mm

Projection

Customer Client	Date
Drawn By Dessiné Par BoxCad: BoxCad	Date 27-Jan-25
Material Matière 16 Ga Cold Rolled A1008 CS Type B (1.4mm)	
Color Couleur Asa-61 Grey	Finish Fini Smooth
Description 1100B 18" x 12" x 4.86" Assembly	Detail Rev.
Part Number Numéro Pièce <b>1100B204</b>	Rev. <b>0</b>

This drawing is confidential and must not be reproduced or used without the consent of EXM

Ce dessin est confidentiel et ne doit pas être reproduit ou utilisé sans le consentement de EXM

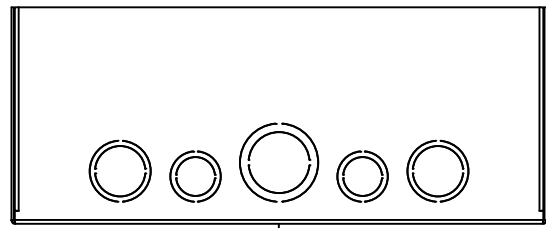

TOP

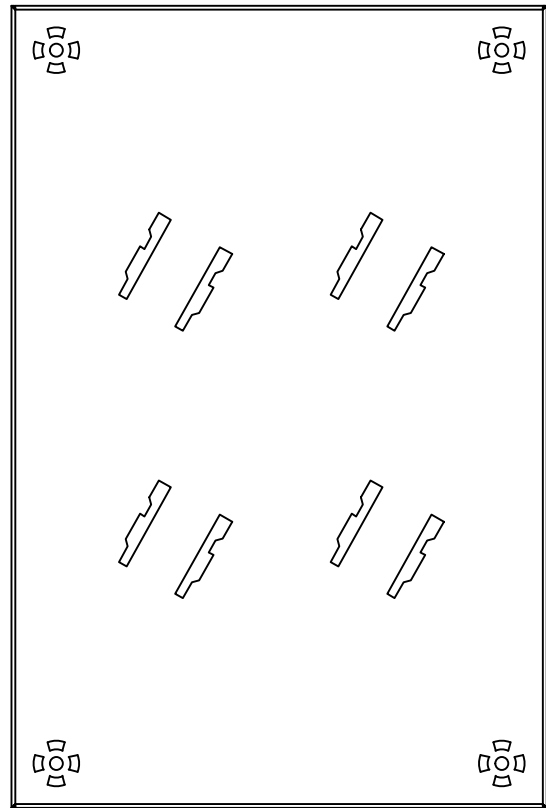

BACK

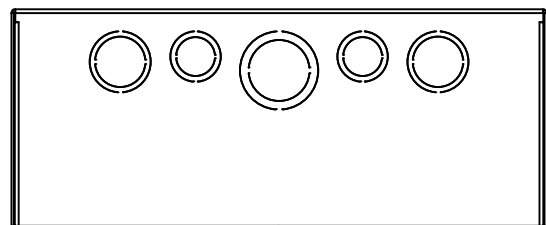

BOTTOM

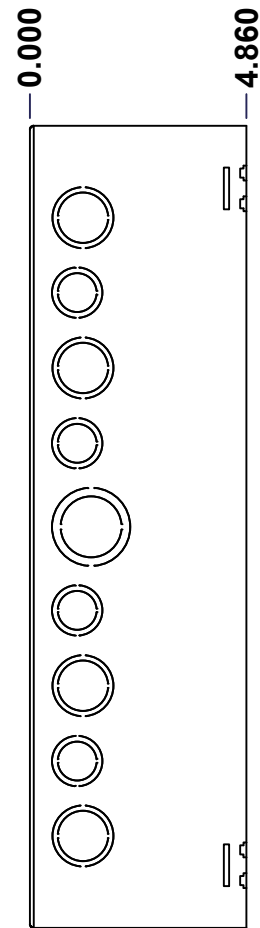

LEFT

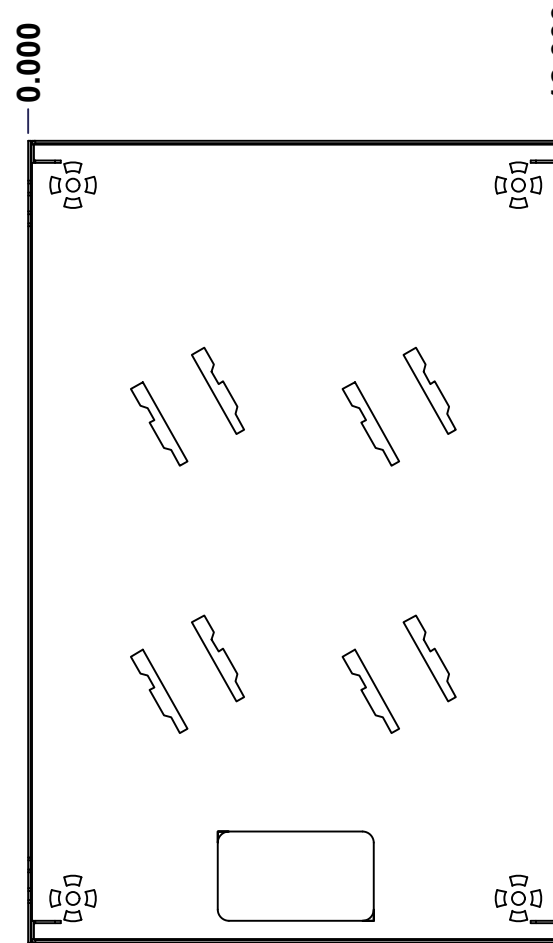

FRONT

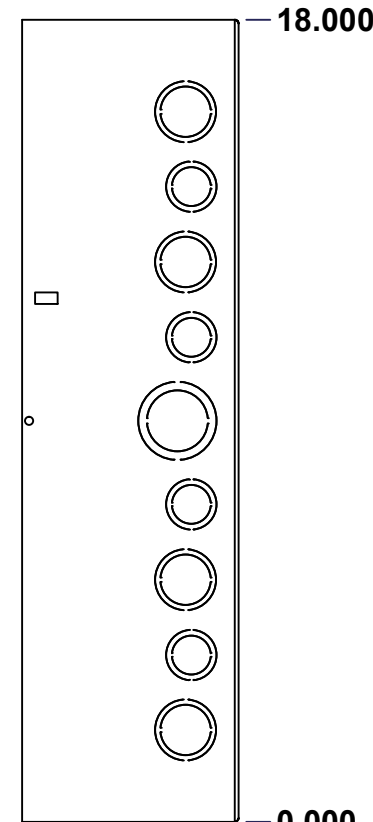

RIGHT

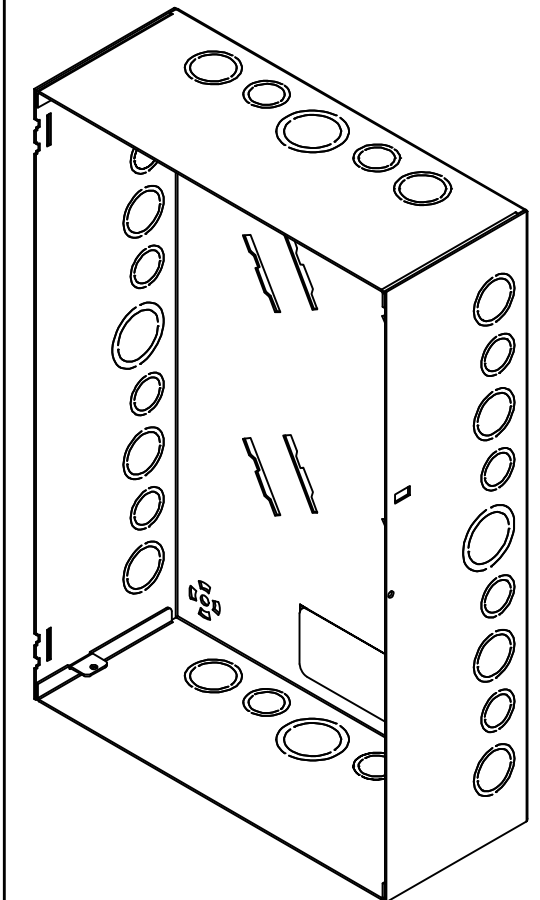

Isometric View

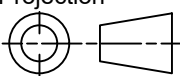

No.	Revisions	Date	By/Par

 Tél: (450) 979-4373 Fax: (450) 979-4626 <a href="http://www.exmweb.com">www.exmweb.com</a>		Flatness Aplatissement Max 3.0mm Projection 
Customer Client	Date	
Drawn By Dessiné Par	BoxCad: BoxCad	Date 27-Jan-25
Material Matière	16 Ga Cold Rolled A1008 CS Type B (1.4mm)	
Color Couleur	Asa-61 Grey	Finish Fini Smooth
Description 1100B 18" x 12" x 4.86" Body		Detail Rev.
Part Number Numéro Pièce	1100B204B	Rev. 3 0

SEE BILL OF MATERIAL ON LAST PAGE

This drawing is confidential and must not be reproduced or used without the consent of EXM

Ce dessin est confidentiel et ne doit pas être reproduit ou utilisé sans le consentement de EXM

**STANDARD FEATURES ARE NOT LISTED IN THIS HOLE TABLE**

**HOLE TABLE - TOP VIEW (CUSTOM FEATURE ONLY)**

CUT-OUT	XDIM	YDIM	DESCRIPTION
1	9.563	1.188	DKO Ø1.375 - 1.125
2	7.875	1.063	DKO Ø1.125 - 0.875
3	6.000	1.375	DKO Ø1.750 - 1.375
4	4.125	1.063	DKO Ø1.125 - 0.875
5	2.437	1.188	DKO Ø1.375 - 1.125

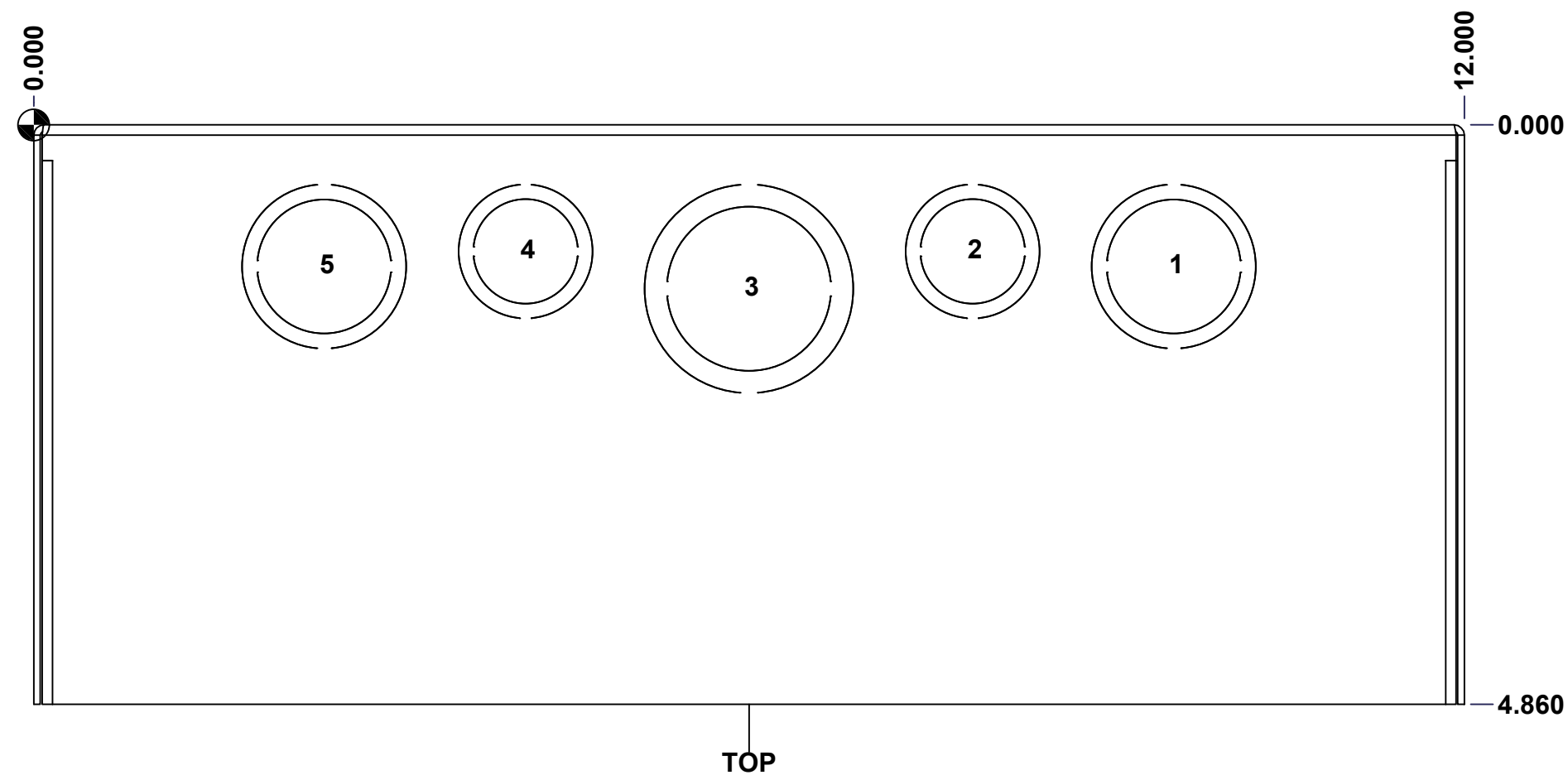

	Description	Status
	1100B 18" x 12" x 4.86" Body	(NULL)
	Part Number Numéro Pièce	Rev.
	<b>1100B204B</b>	<b>0</b>
		4
		10

This drawing is confidential and must not be reproduced or used without the consent of EXM

Ce dessin est confidentiel et ne doit pas être reproduit ou utilisé sans le consentement de EXM

**STANDARD FEATURES ARE NOT LISTED IN THIS HOLE TABLE**

**HOLE TABLE - RIGHT VIEW (CUSTOM FEATURE ONLY)**

CUT-OUT	XDIM	YDIM	DESCRIPTION
1	1.188	15.939	DKO Ø1.375 - 1.125
2	1.063	14.251	DKO Ø1.125 - 0.875
3	1.188	12.563	DKO Ø1.375 - 1.125
4	1.063	10.875	DKO Ø1.125 - 0.875
5	1.375	9.000	DKO Ø1.750 - 1.375
6	1.063	7.125	DKO Ø1.125 - 0.875
7	1.188	5.437	DKO Ø1.375 - 1.125
8	1.063	3.749	DKO Ø1.125 - 0.875
9	1.188	2.061	DKO Ø1.375 - 1.125

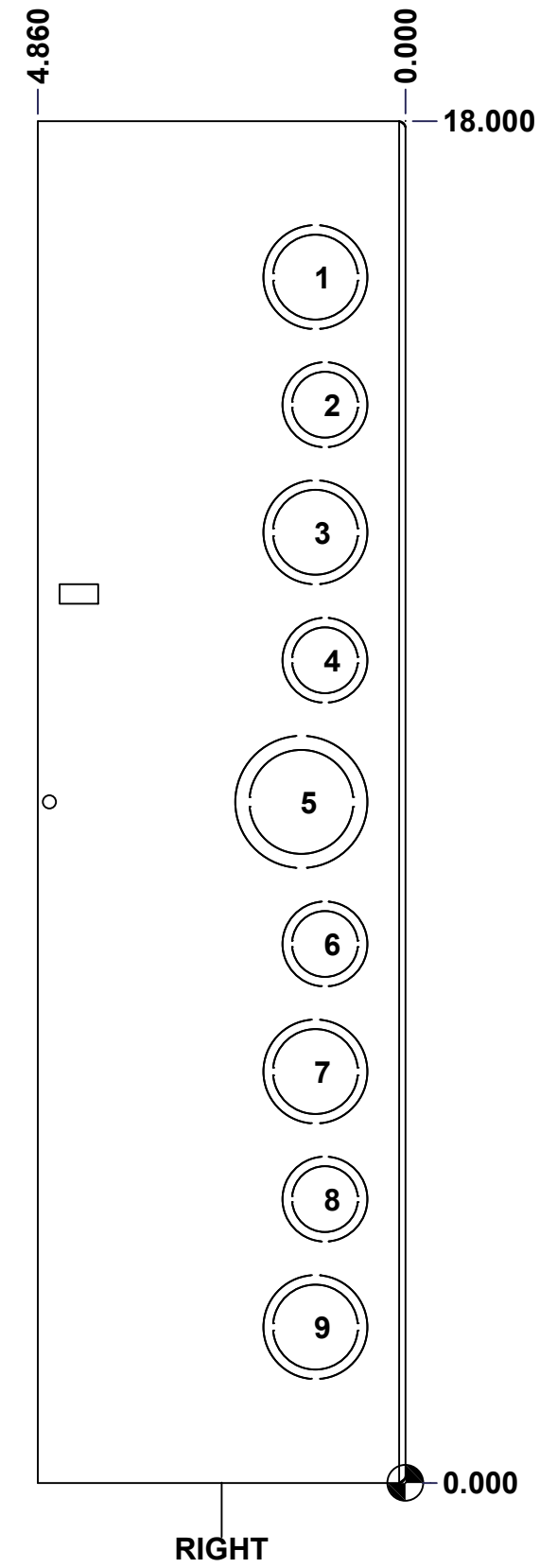

	Description 1100B 18" x 12" x 4.86" Body	Status (NULL)
	Part Number Numéro Pièce <b>1100B204B</b>	Rev. 5 <b>0</b>

This drawing is confidential and must not be reproduced or used without the consent of EXM

Ce dessin est confidentiel et ne doit pas être reproduit ou utilisé sans le consentement de EXM

**STANDARD FEATURES ARE NOT LISTED IN THIS HOLE TABLE**

**HOLE TABLE - BOTTOM VIEW (CUSTOM FEATURE ONLY)**

CUT-OUT	XDIM	YDIM	DESCRIPTION
1	9.563	1.188	DKO Ø1.375 - 1.125
2	7.875	1.063	DKO Ø1.125 - 0.875
3	6.000	1.375	DKO Ø1.750 - 1.375
4	4.125	1.063	DKO Ø1.125 - 0.875
5	2.437	1.188	DKO Ø1.375 - 1.125

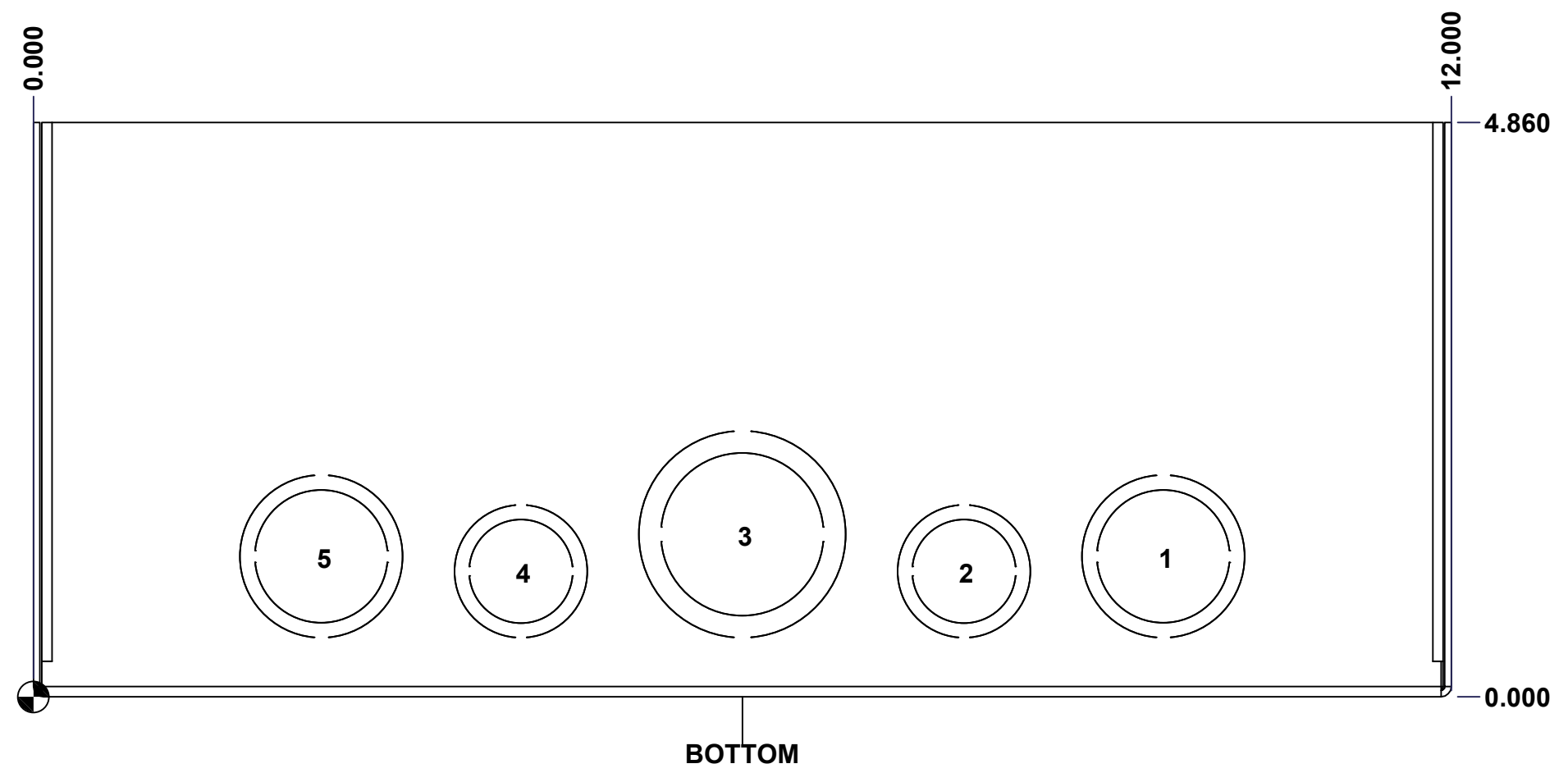

	Description 1100B 18" x 12" x 4.86" Body	Status (NULL)
	Part Number Numéro Pièce <b>1100B204B</b>	Rev. 6 <b>0</b> / 10

This drawing is confidential and must not be reproduced or used without the consent of EXM

Ce dessin est confidentiel et ne doit pas être reproduit ou utilisé sans le consentement de EXM

**STANDARD FEATURES ARE NOT LISTED IN THIS HOLE TABLE**

**HOLE TABLE - LEFT VIEW (CUSTOM FEATURE ONLY)**

CUT-OUT	XDIM	YDIM	DESCRIPTION
1	1.188	15.939	DKO Ø1.375 - 1.125
2	1.063	14.251	DKO Ø1.125 - 0.875
3	1.188	12.563	DKO Ø1.375 - 1.125
4	1.063	10.875	DKO Ø1.125 - 0.875
5	1.375	9.000	DKO Ø1.750 - 1.375
6	1.063	7.125	DKO Ø1.125 - 0.875
7	1.188	5.437	DKO Ø1.375 - 1.125
8	1.063	3.749	DKO Ø1.125 - 0.875
9	1.188	2.061	DKO Ø1.375 - 1.125

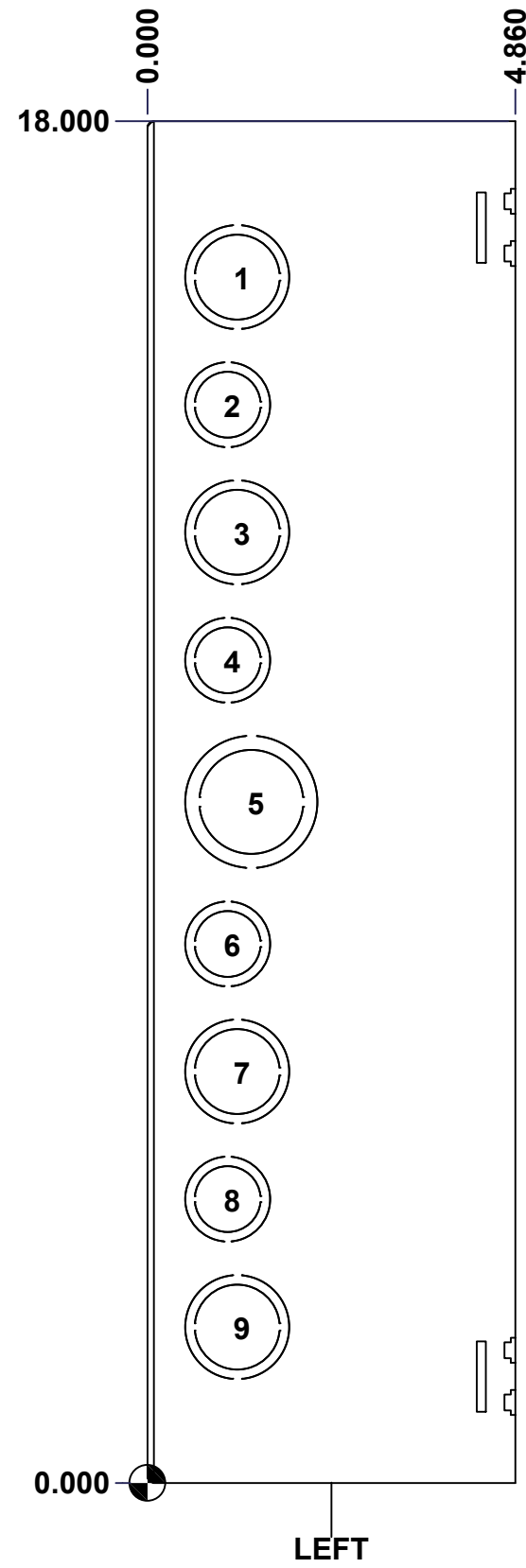



	Description	Status	
	1100B 18" x 12" x 4.86" Body	(NULL)	
	Part Number Numéro Pièce	Rev.	7
	<b>1100B204B</b>	<b>0</b>	10

This drawing is confidential and must not be reproduced or used without the consent of EXM

Ce dessin est confidentiel et ne doit pas être reproduit ou utilisé sans le consentement de EXM

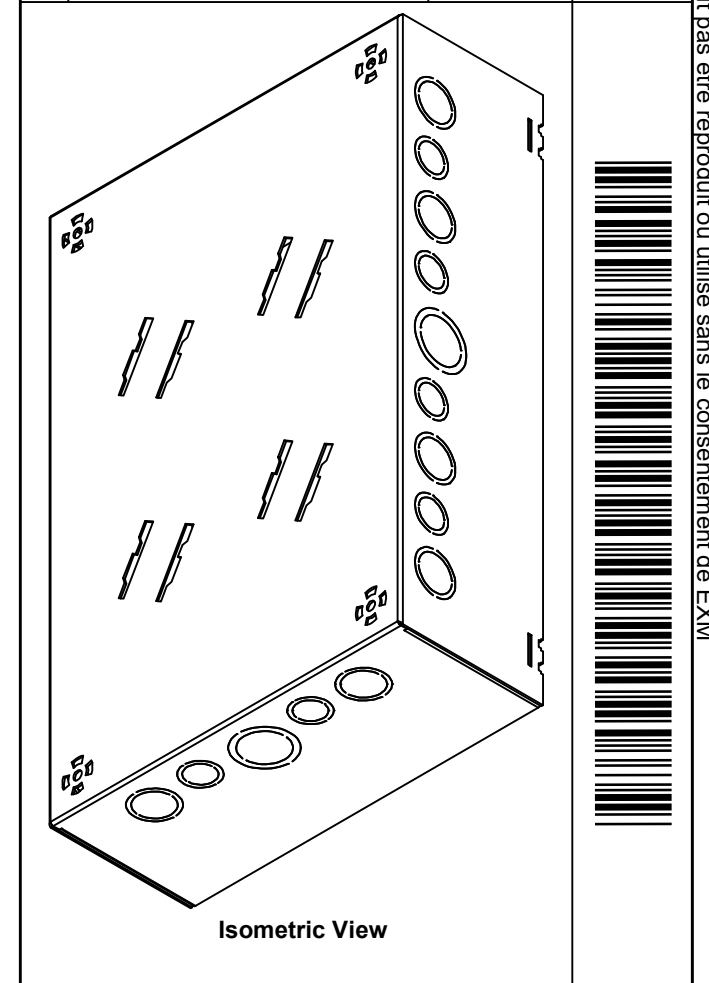
No.	Revisions	Date	By/Par

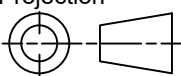

 Tél: (450) 979-4373 Fax: (450) 979-4626 <a href="http://www.exmweb.com">www.exmweb.com</a>		Flatness Aplatissement Max 3.0mm
Customer Client		Projection 
Drawn By Dessiné Par BoxCad: BoxCad		Date 27-Jan-25
Material Matière 16 Ga Cold Rolled A1008 CS Type B (1.4mm)		
Color Couleur Asa-61 Grey	Finish Fini Smooth	
Description 1100B 18" x 12" x 4.86" Body		Detail Rev.
Part Number Numéro Pièce <b>1100B204B</b>		Rev. 8 <b>0</b>

Qty	Part Number	Rev	Description
1	STK-P-02400S	0	Powder Paint (Asa-61 Grey / Smooth)
1	STK-S-00100	0	3.5" x 2" Silver Milar Flexcon Sticker
1	1100B204B-P	0	1100B 18" x 12" x 4.86" Body Part
Parts List			



This drawing is confidential and must not be reproduced or used without the consent of EXM

Ce dessin est confidentiel et ne doit pas être reproduit ou utilisé sans le consentement de EXM

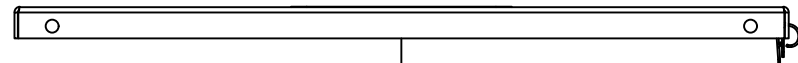

TOP

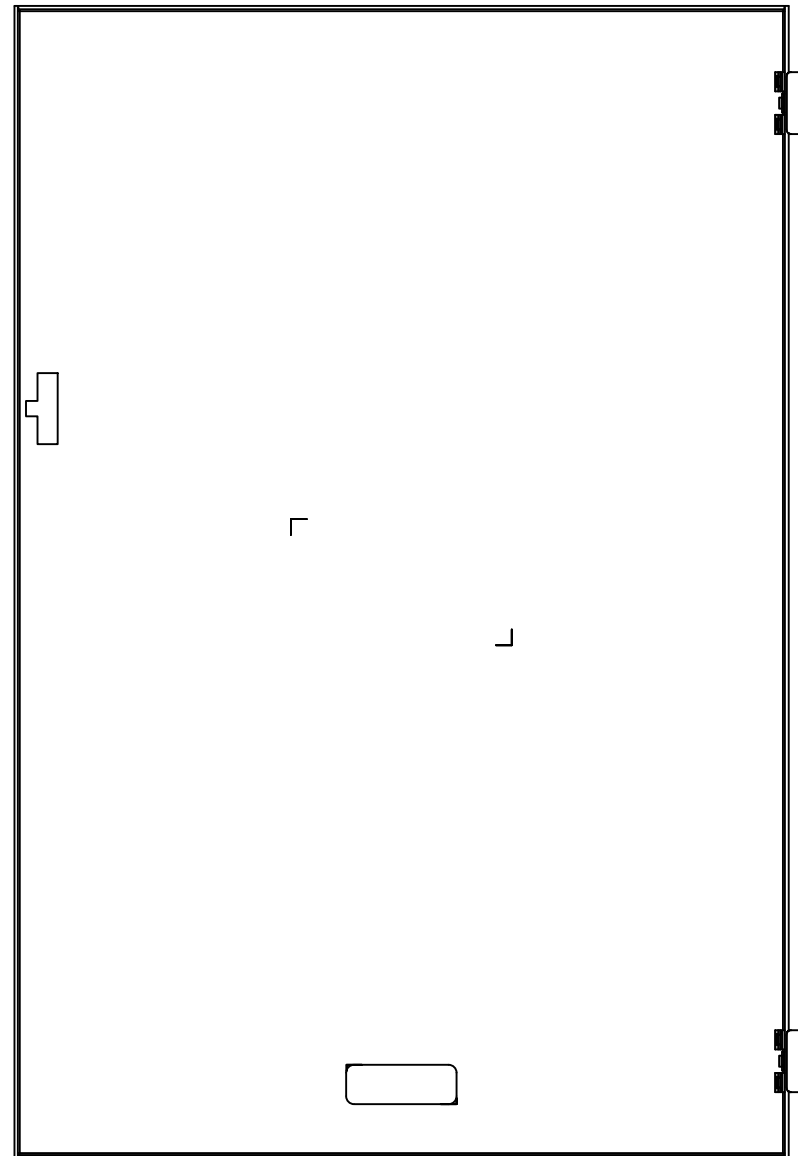

BACK

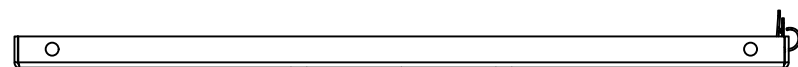

BOTTOM

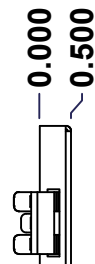

LEFT

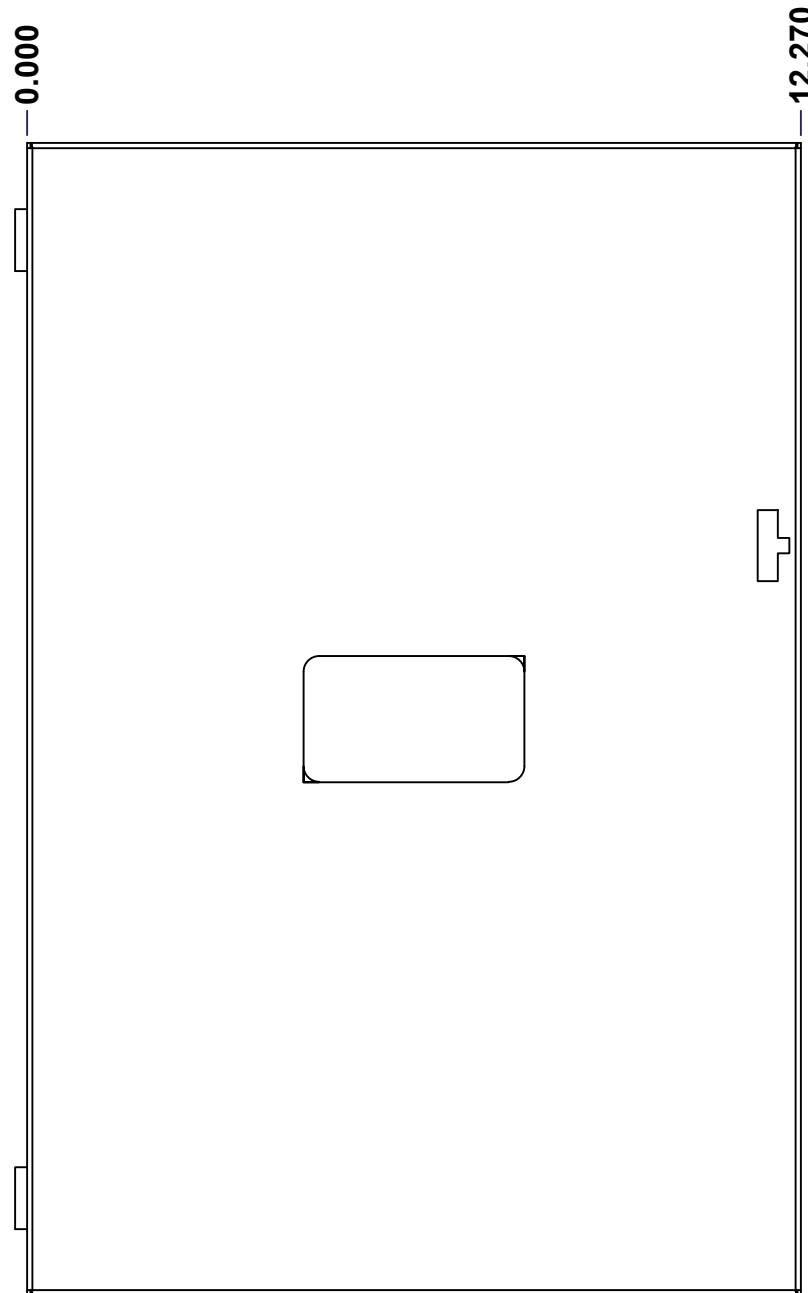

FRONT

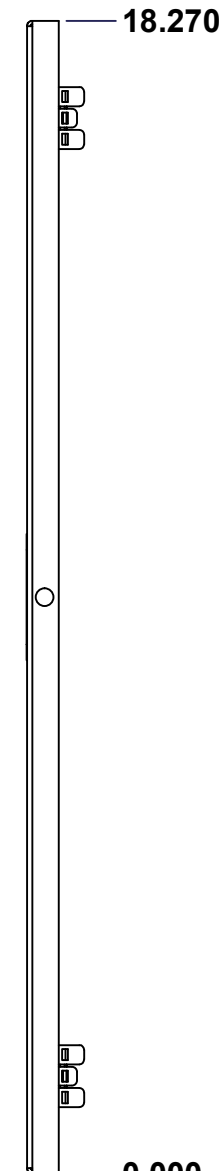

RIGHT

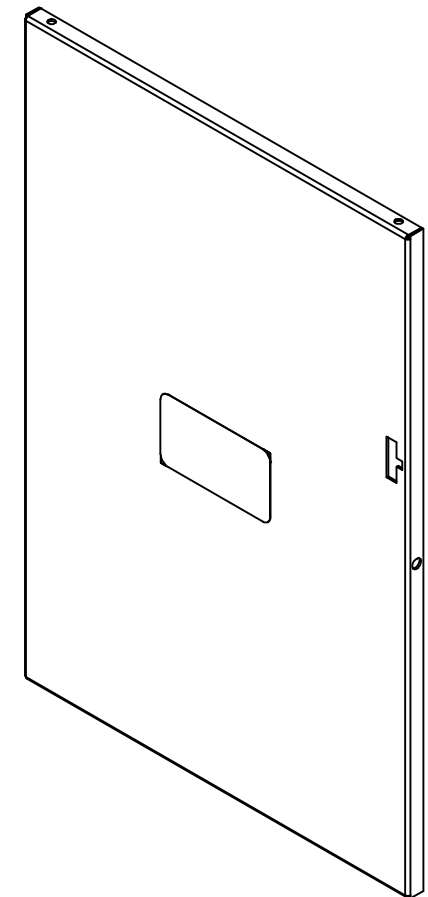

Isometric View

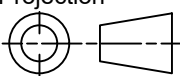

No.	Revisions	Date	By/Par

 Tél: (450) 979-4373 Fax: (450) 979-4626 <a href="http://www.exmweb.com">www.exmweb.com</a>		Flatness Aplatissement Max 3.0mm Projection 
Customer Client	Date	
Drawn By Dessiné Par	BoxCad: BoxCad	Date 27-Jan-25
Material Matière	16 Ga Cold Rolled A1008 CS Type B (1.4mm)	
Color Couleur	Asa-61 Grey	Finish Fini Smooth
Description	Detail Rev.	
1100B 18" x 12" Cover		
Part Number Numéro Pièce	Rev.	9
1100B204C	0	10

SEE BILL OF MATERIAL ON LAST PAGE

This drawing is confidential and must not be reproduced or used without the consent of EXM

Ce dessin est confidentiel et ne doit pas être reproduit ou utilisé sans le consentement de EXM

No.	Revisions	Date	By/Par

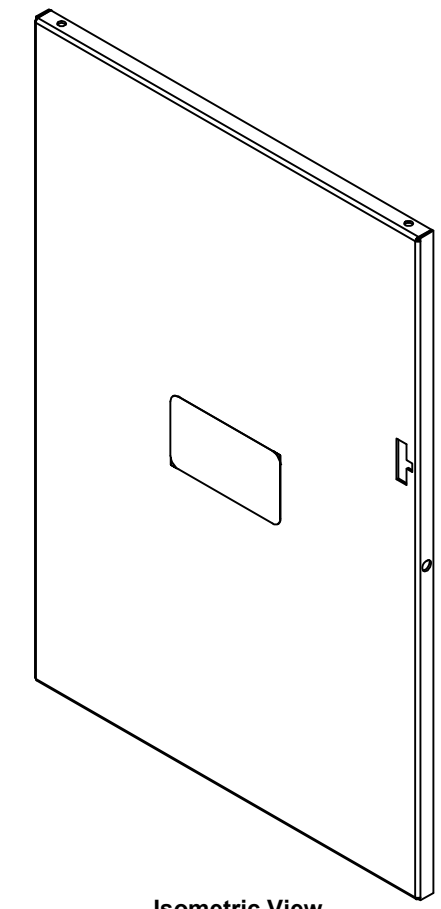

Isometric View

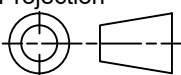

 Tél: (450) 979-4373 Fax: (450) 979-4626 <a href="http://www.exmweb.com">www.exmweb.com</a>		Flatness Aplatissement Max 3.0mm Projection 
Customer Client	Date	
Drawn By / Dessiné Par: BoxCad: BoxCad	Date: 27-Jan-25	
Material / Matière: 16 Ga Cold Rolled A1008 CS Type B (1.4mm)		
Color / Couleur: Asa-61 Grey	Finish / Fini: Smooth	
Description: 1100B 18" x 12" Cover		Detail Rev.
Part Number / Numéro Pièce: <b>1100B204C</b>	Rev.: <b>0</b>	10 / 10

QTY	Part Number	Rev	Description
1	STK-P-02400S	0	Powder Paint (Asa-61 Grey / Smooth)
1	STK-S-00250	0	15.8mm x 44.45mm Silver Milar Sticker
1	STK-S-00100	0	3.5" x 2" Silver Milar Flexcon Sticker
2	STK-Q-33361	0	Spring Steel Hinge
1	1100B204C-P	0	1100B 18" x 12" x 0" Cover Part
Parts List			