

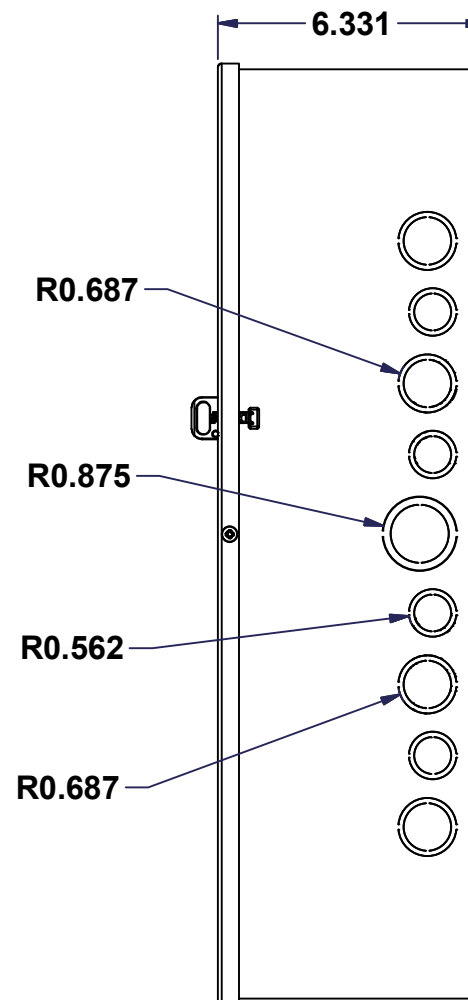

This drawing is confidential and must not be reproduced or used without the consent of EXM

All knockouts are actual size / Les disques défonçables sont grandeur réel
 All dimensions are before paint / Toutes les dimensions sont avant peinture

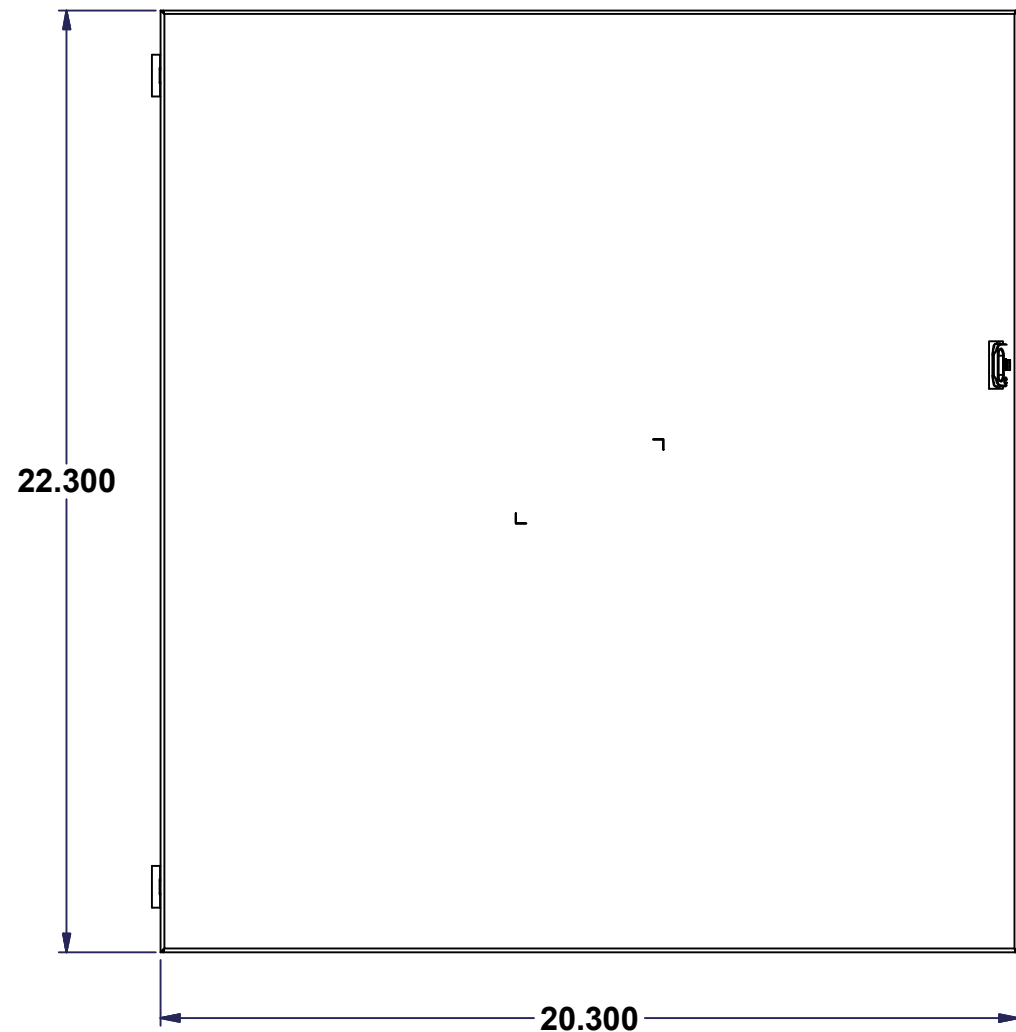
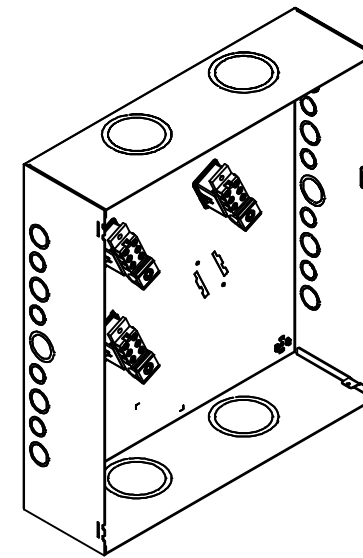
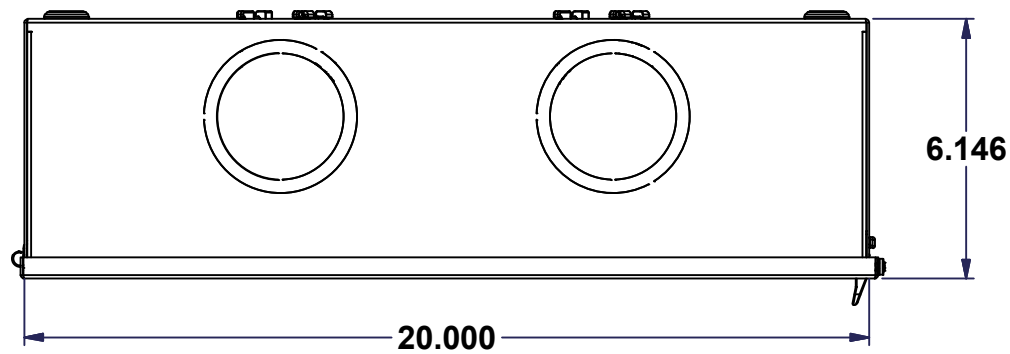
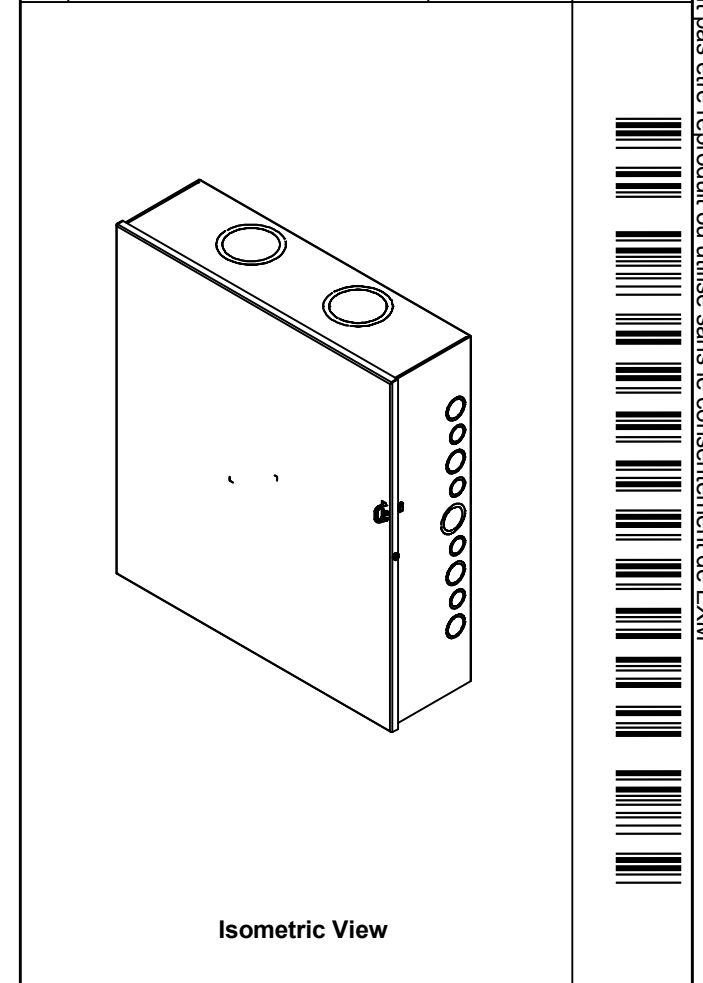

No.	Revisions	Date	By/Par
1	Add laser cut on ground bend, KO was 0.625" to back and 125AMP use STK-Q-67220	10/12/2012	AllenL
1.1	Change insulator grooves distance to 16mm on 1100B73 and 1100B74	28/3/2013	AllenL



 Tél: (450) 979-4373 Fax: (450) 979-4626 www.exmweb.com		Flatness Aplatissement	
		Max 3.0mm	
Customer Client		Date	
EXM Manufacturin		Date 28-Jan-15	
Drawn By Dessiné Par		Date	
MichaelA		28-Jan-15	
Material Matière		See Part List	
Color Couleur		Finish Fini	
See Part List		See Part List	
Description			Detail Rev.
1100B403 22" x 20" x 6" - 3 Wire Assembly			
Part Number Numéro Pièce		Rev.	
1100B403		1	3

Ce dessin est confidentiel et ne doit pas être reproduit ou utilisé sans le consentement de EXM

This drawing is confidential and must not be reproduced or used without the consent of EXM

All knockouts are actual size / Les disques défonçables sont grandeur réel
 All dimensions are before paint / Toutes les dimensions sont avant peinture

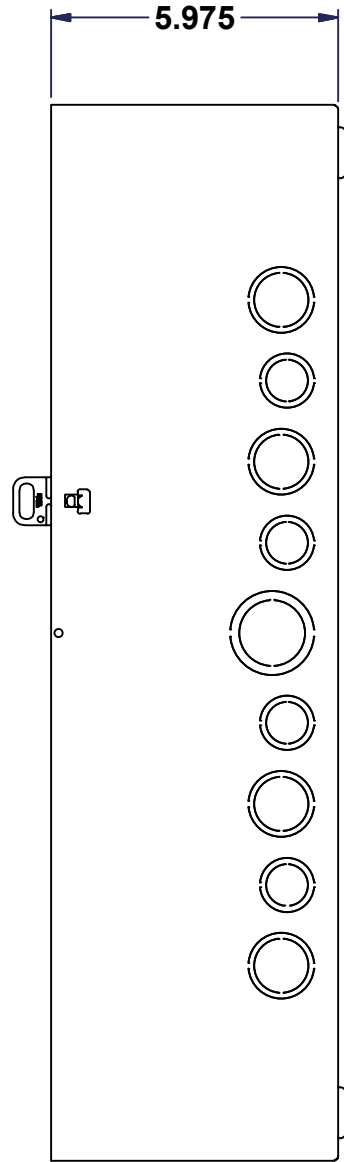
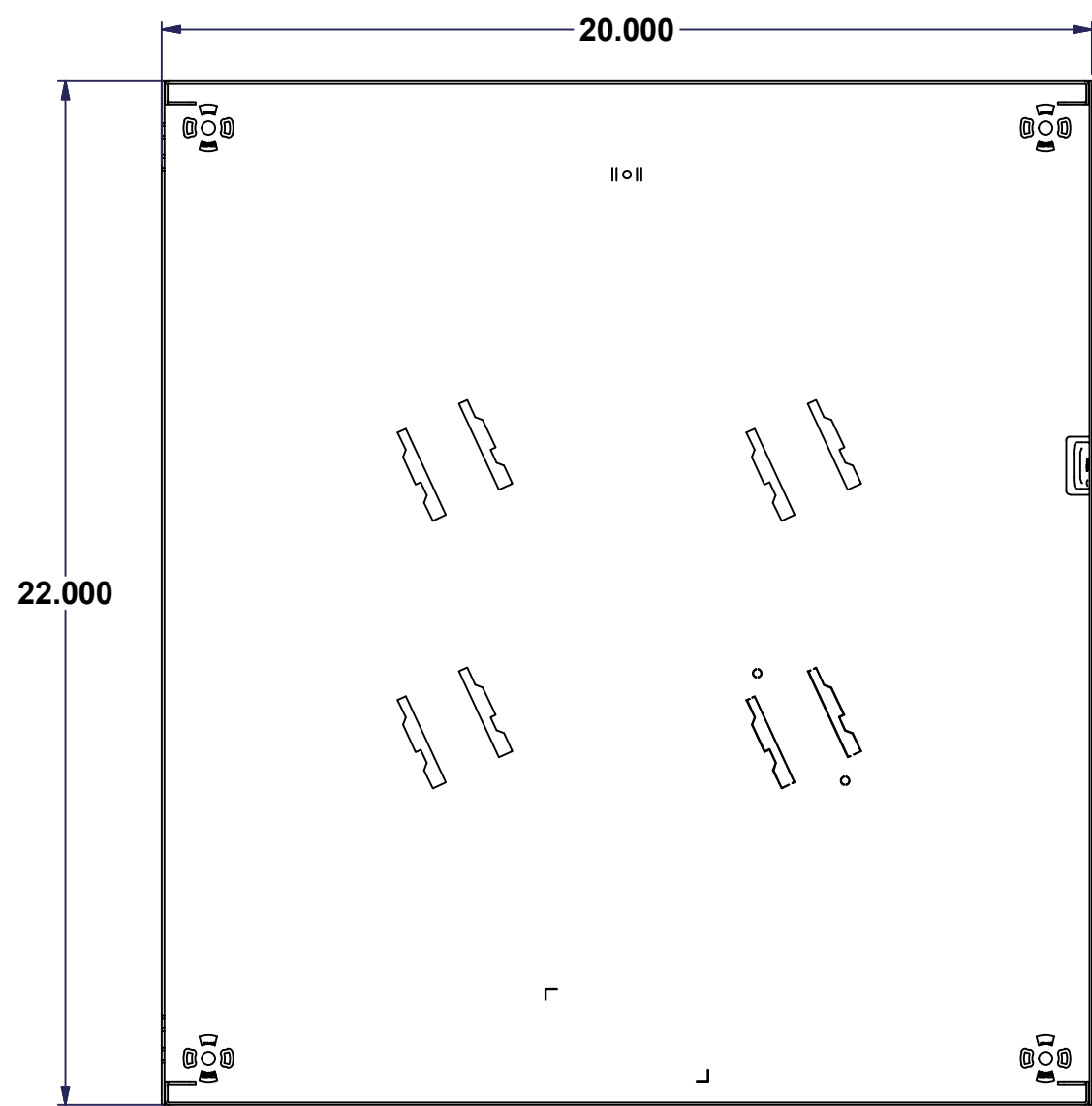
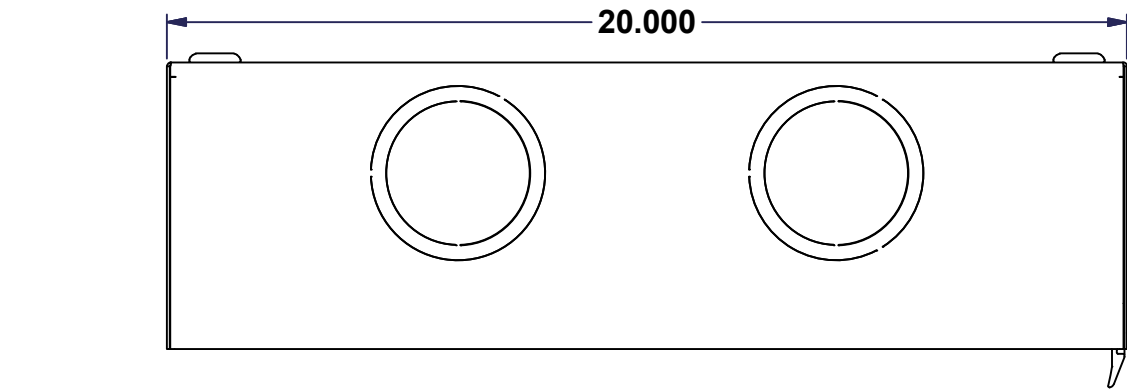

No.	Revisions	Date	By/Par
1	Add laser cut on ground bend, KO was 0.625" to back and 125AMP use STK-Q-67220	10/12/2012	AllenL
1.1	Change insulator grooves distance to 16mm on 1100B73 and 1100B74	28/3/2013	AllenL

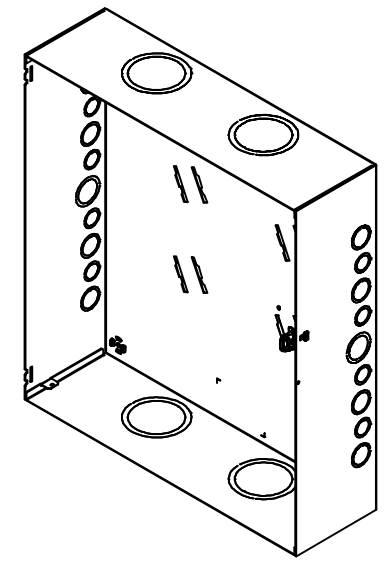

Isometric View

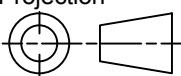

Ce dessin est confidentiel et ne doit pas être reproduit ou utilisé sans le consentement de EXM

 Tél: (450) 979-4373 Fax: (450) 979-4626 www.exmweb.com	Flatness Aplatissement Max 3.0mm
	Projection 
Customer Client EXM Manufacturin	Date
Drawn By Dessiné Par MichaelA	Date 28-Jan-15
Material Matière See Part List	
Color Couleur See Part List	Finish Fini See Part List
Description 1100B 22" x 20" x 6" 3 Wire - Body	
Detail Rev.	
Part Number Numéro Pièce 1100B403B	Rev. 1 2 3

This drawing is confidential and must not be reproduced or used without the consent of EXM

All knockouts are actual size / Les disques défonçables sont grandeur réel
 All dimensions are before paint / Toutes les dimensions sont avant peinture

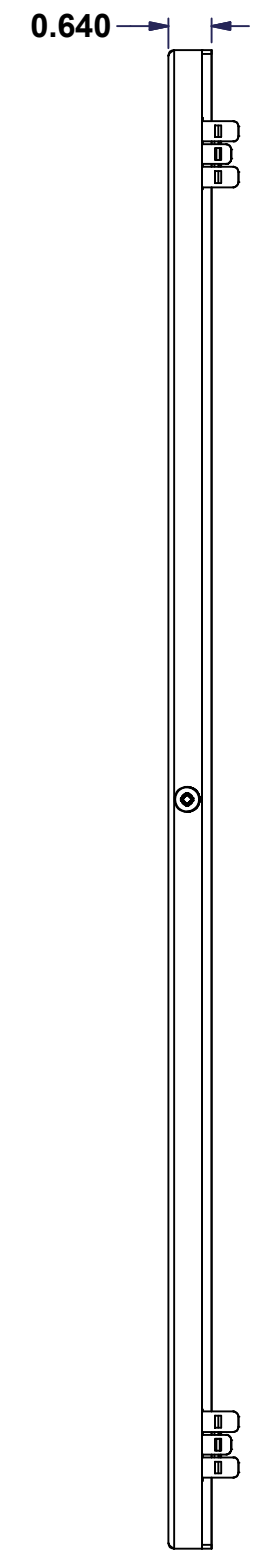
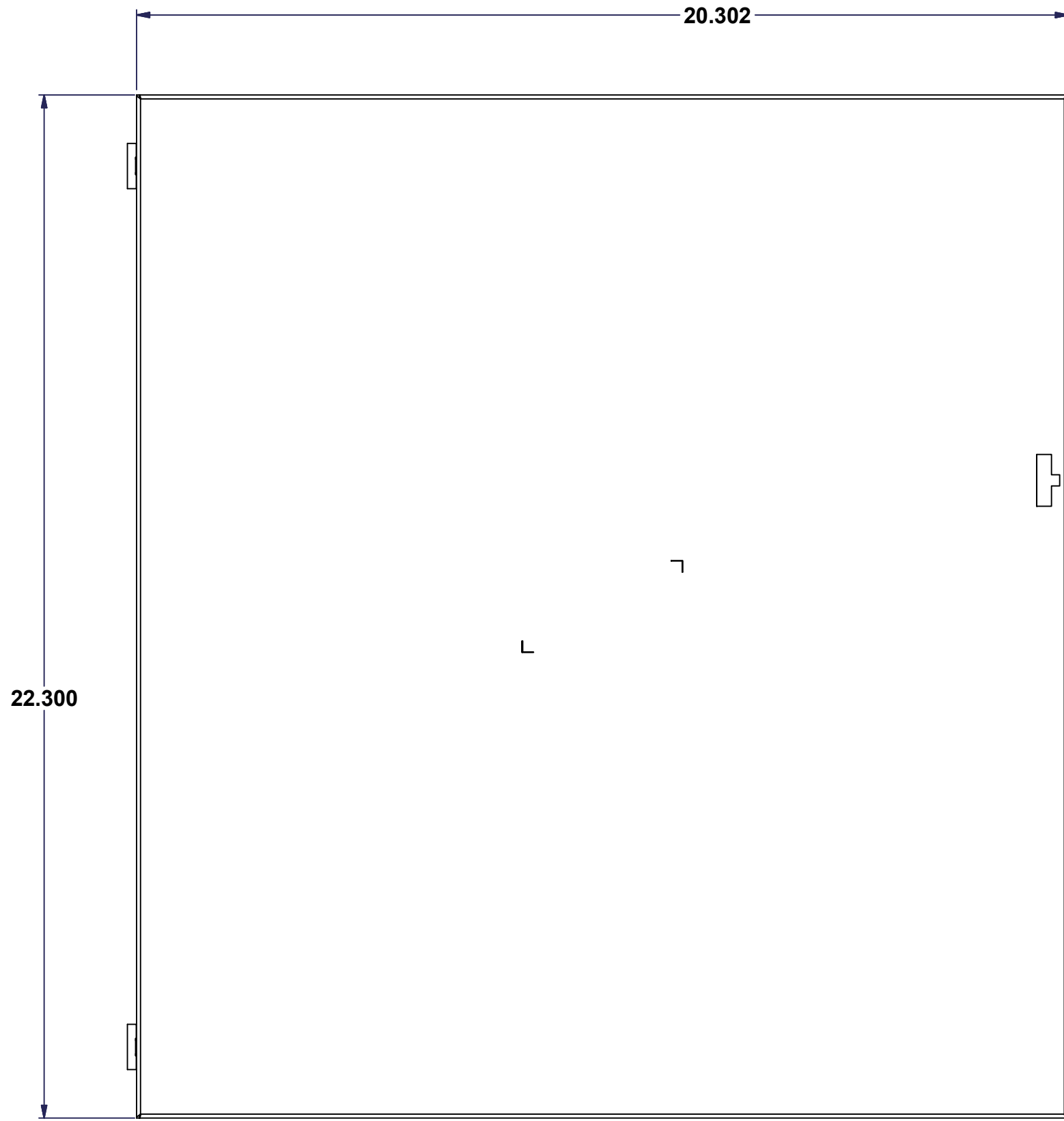

No.	Revisions	Date	By/Par
1	Revision Update As Body	10/12/2012	AllenL
1.1	Revision update as body part	28/3/2013	AllenL

Isometric View

Tél: (450) 979-4373 Fax: (450) 979-4626 www.exmweb.com		Flatness Aplatissement	
		Max 3.0mm	
Customer Client		Date	
EXM Manufacturin		Date 28-Jan-15	
Drawn By Dessiné Par		Date	
MichaelA		28-Jan-15	
Material Matière			
See Part List			
Color Couleur		Finish Fini	
See Part List		See Part List	
Description			Detail Rev.
1100B 22" x 20" - Cover			
Part Number Numéro Pièce		Rev.	
1100B403C		1	3 3

Ce dessin est confidentiel et ne doit pas être reproduit ou utilisé sans le consentement de EXM