

This drawing is confidential and must not be reproduced or used without the consent of EXM

All knockouts are actual size / Les disques défonçables sont grandeur réel
 All dimensions are before paint / Toutes les dimensions sont avant peinture

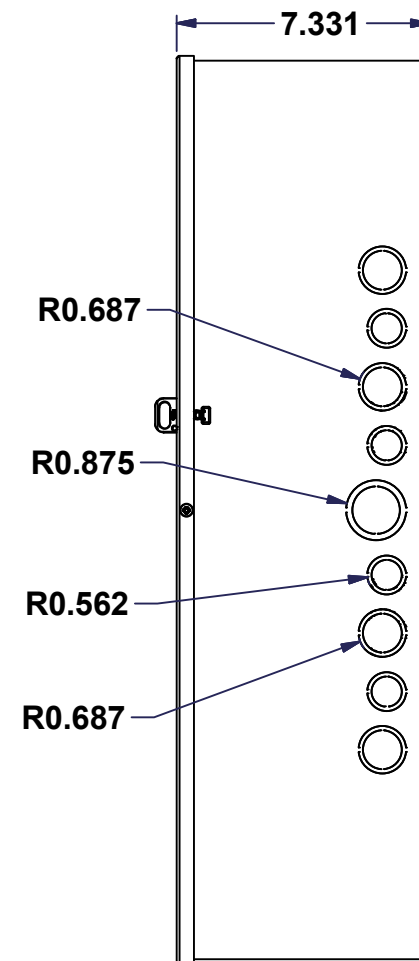

No.	Revisions	Date	By/Par
1	Add laser cut on ground bend, KO was 0.625" to back and 125AMP use STK-Q-67220	10/12/2012	AllenL
1.1	Change insulator grooves distance to 16mm on 1100B73 and 1100B74	28/3/2013	AllenL

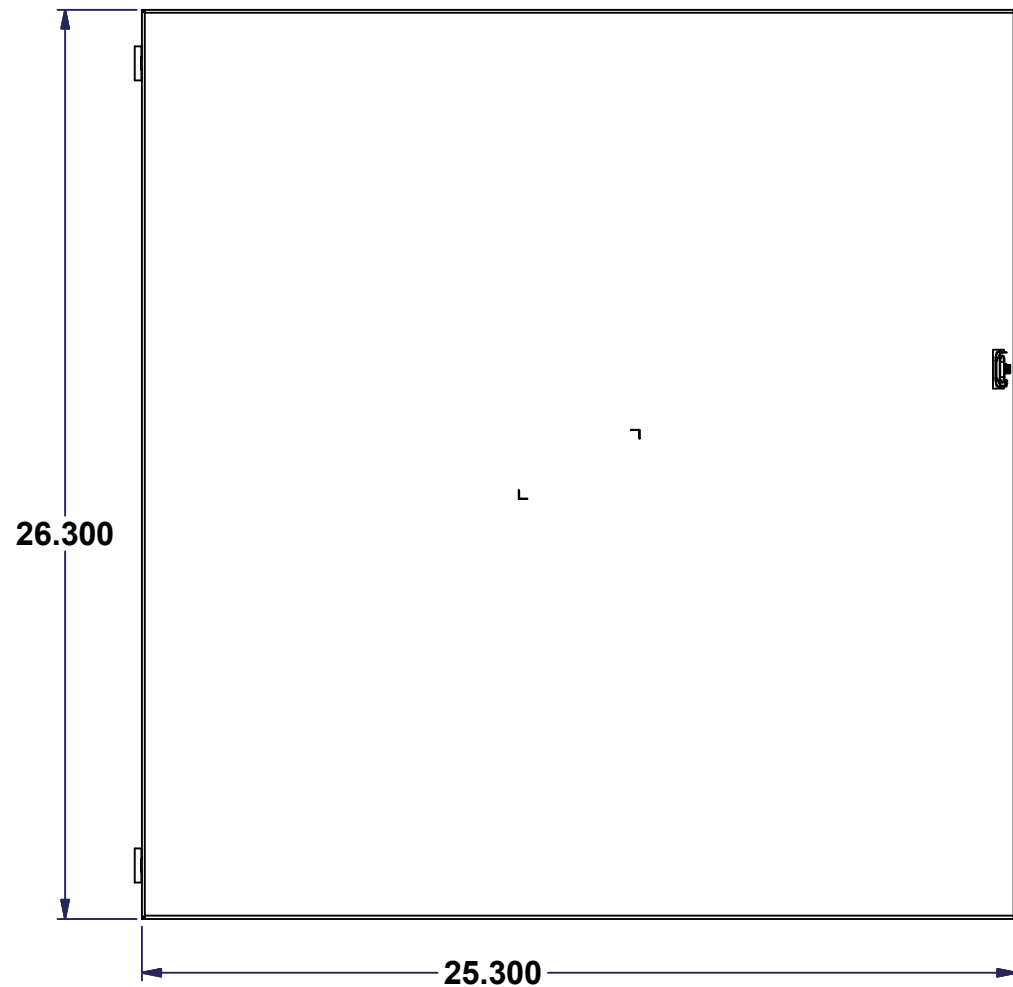
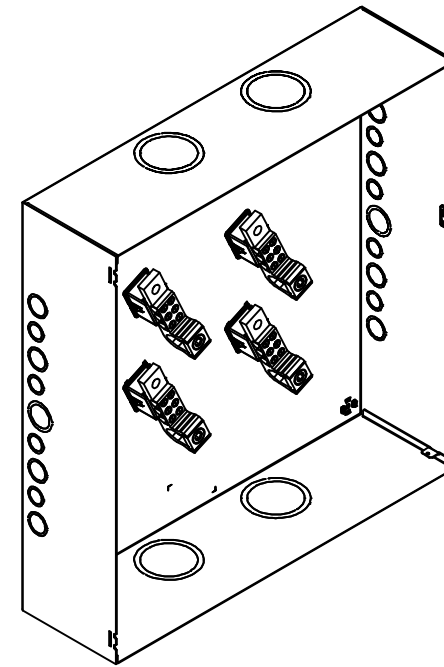
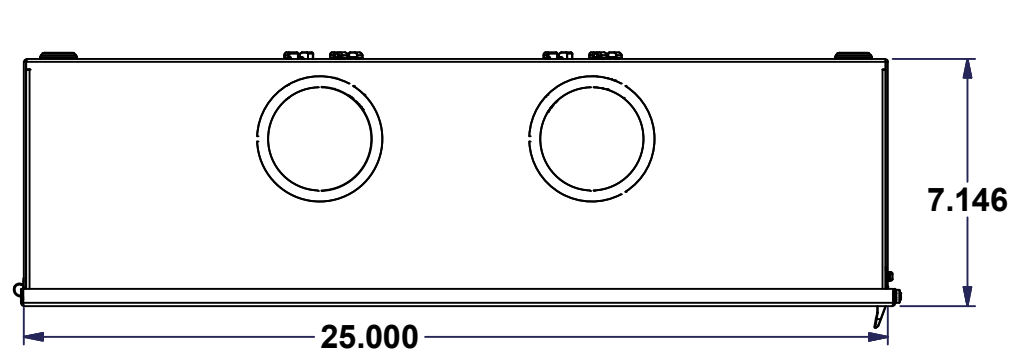
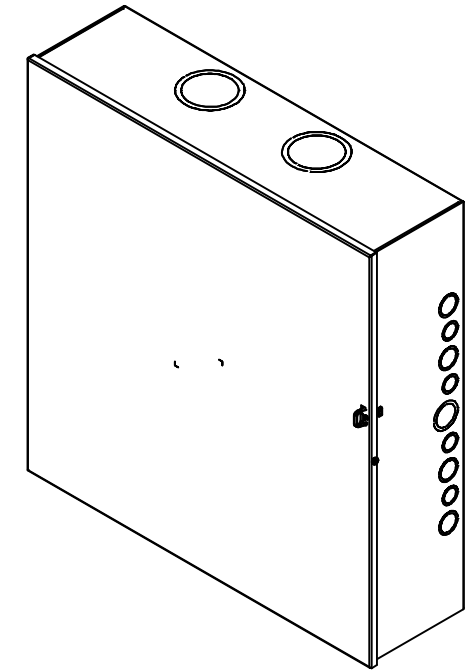

Isometric View



Ce dessin est confidentiel et ne doit pas être reproduit ou utilisé sans le consentement de EXM

Tél: (450) 979-4373 Fax: (450) 979-4626 www.exmweb.com		Flatness Aplatissement Max 3.0mm Projection
Customer Client	EXM Manufacturin	Date
Drawn By / Dessiné Par	MichaelA	Date 28-Jan-15
Material Matière	See Part List	
Color Couleur	See Part List	Finish Fini See Part List
Description		Detail Rev.
1100B604 26" x 25" x 7" - 4 Wire Assembly		
Part Number / Numéro Pièce	Rev.	
1100B604	1	1 / 3

This drawing is confidential and must not be reproduced or used without the consent of EXM

All knockouts are actual size / Les disques défonçables sont grandeur réel
 All dimensions are before paint / Toutes les dimensions sont avant peinture

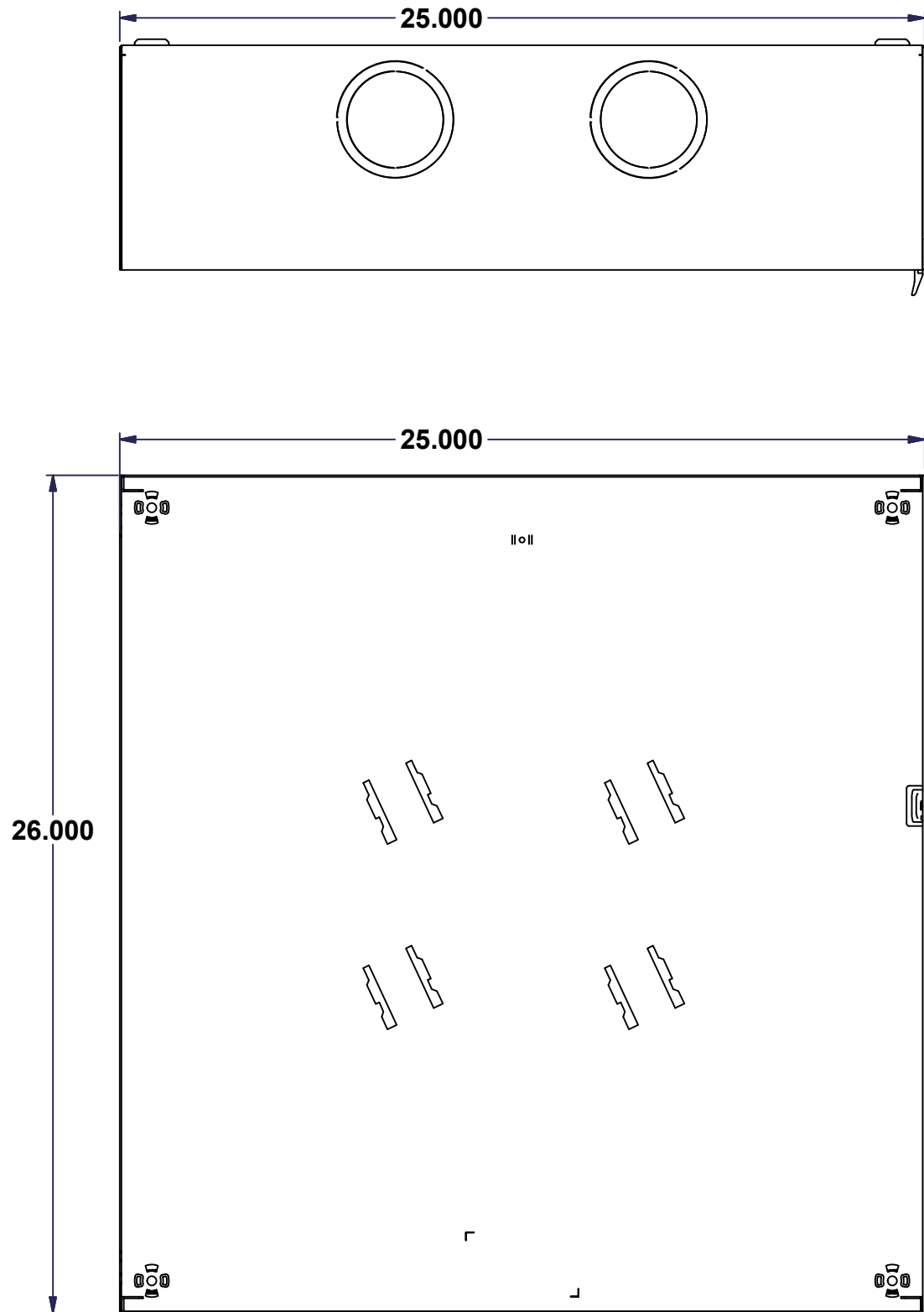

No.	Revisions	Date	By/Par
1	Add laser cut on ground bend, KO was 0.625" to back and 125AMP use STK-Q-67220	10/12/2012	AllenL
1.1	Change insulator grooves distance to 16mm on 1100B73 and 1100B74	28/3/2013	AllenL

Isometric View

Ce dessin est confidentiel et ne doit pas être reproduit ou utilisé sans le consentement de EXM

Tél: (450) 979-4373 Fax: (450) 979-4626 www.exmweb.com		Flatness Aplatissement Max 3.0mm Projection
Customer Client	EXM Manufacturin	Date
Drawn By / Dessiné Par	MichaelA	Date 28-Jan-15
Material Matière	See Part List	
Color Couleur	See Part List	Finish Fini See Part List
Description		Detail Rev.
1100B 26" x 25" x 7" 4 Wire - Body		
Part Number / Numéro Pièce	Rev.	
1100B604B	1	2 / 3

This drawing is confidential and must not be reproduced or used without the consent of EXM

All knockouts are actual size / Les disques défonçables sont grandeur réel
 All dimensions are before paint / Toutes les dimensions sont avant peinture

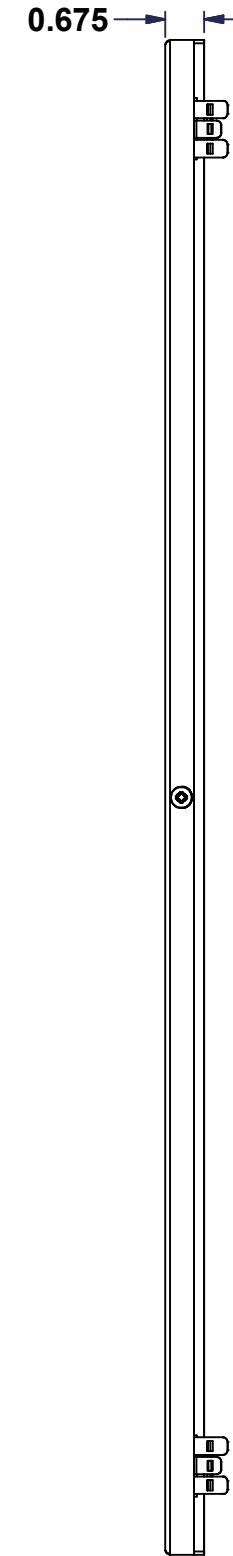
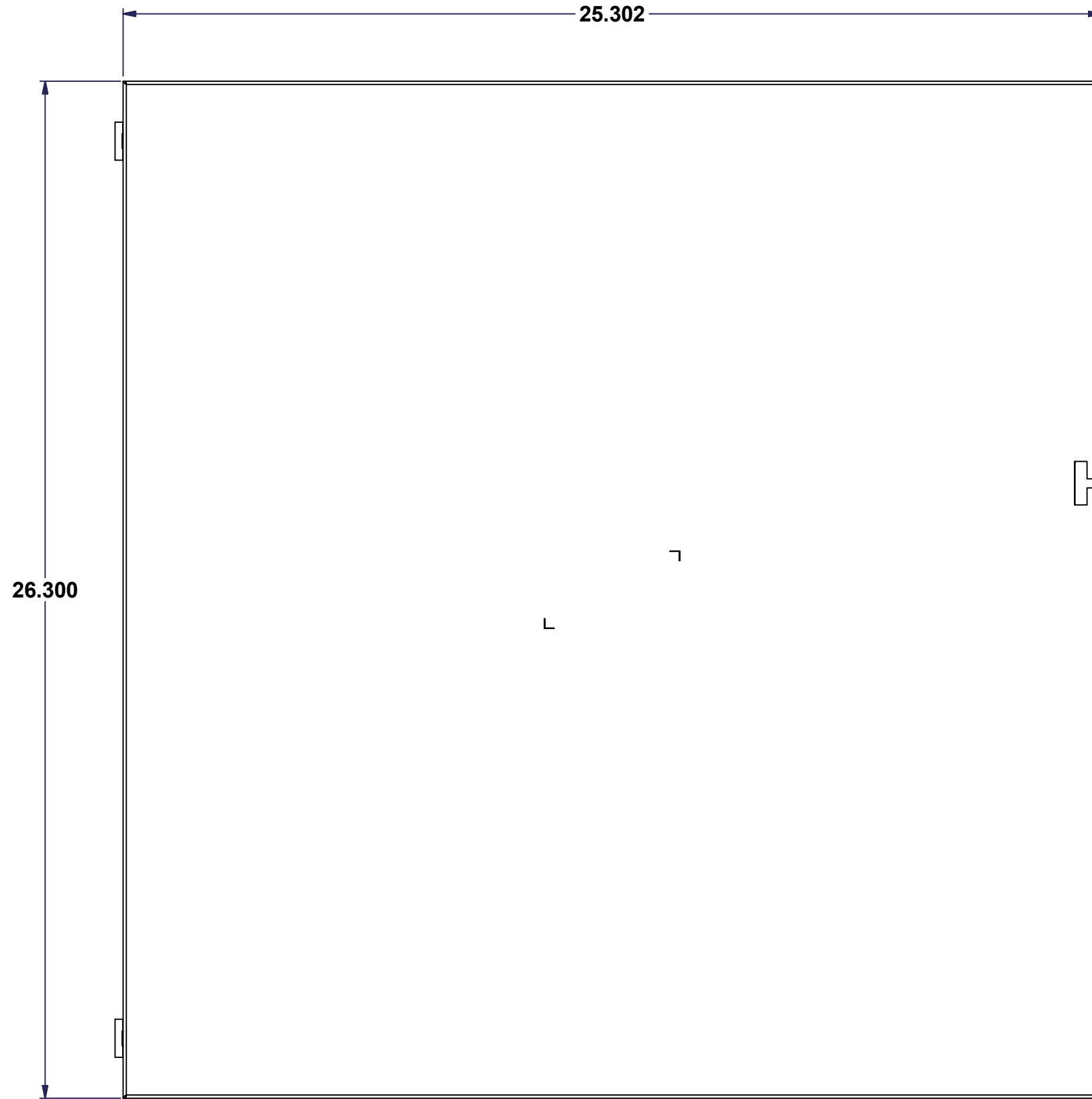

No.	Revisions	Date	By/Par
1	Revision Update As Body	10/12/2012	AllenL
1.1	Revision update as body part	28/3/2013	AllenL

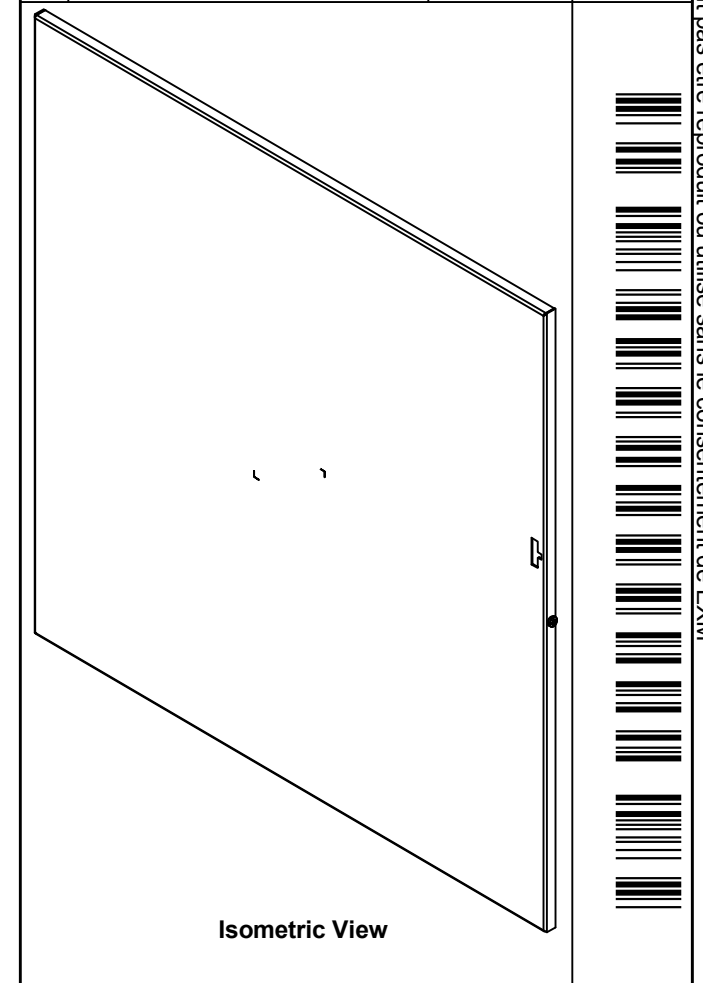

Ce dessin est confidentiel et ne doit pas être reproduit ou utilisé sans le consentement de EXM

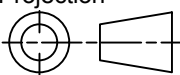
 Tél: (450) 979-4373 Fax: (450) 979-4626 www.exmweb.com		Flatness Aplatissement
		Max 3.0mm
Customer Client: EXM Manufacturin Drawn By / Dessiné Par: MichaelA Material / Matière: See Part List Color / Couleur: See Part List Description: 1100B 26" x 25" - Cover Part Number / Numéro Pièce: 1100B604C		Projection  Date: 28-Jan-15 Finish / Fini: See Part List Detail Rev.: Rev. 1 / 3