

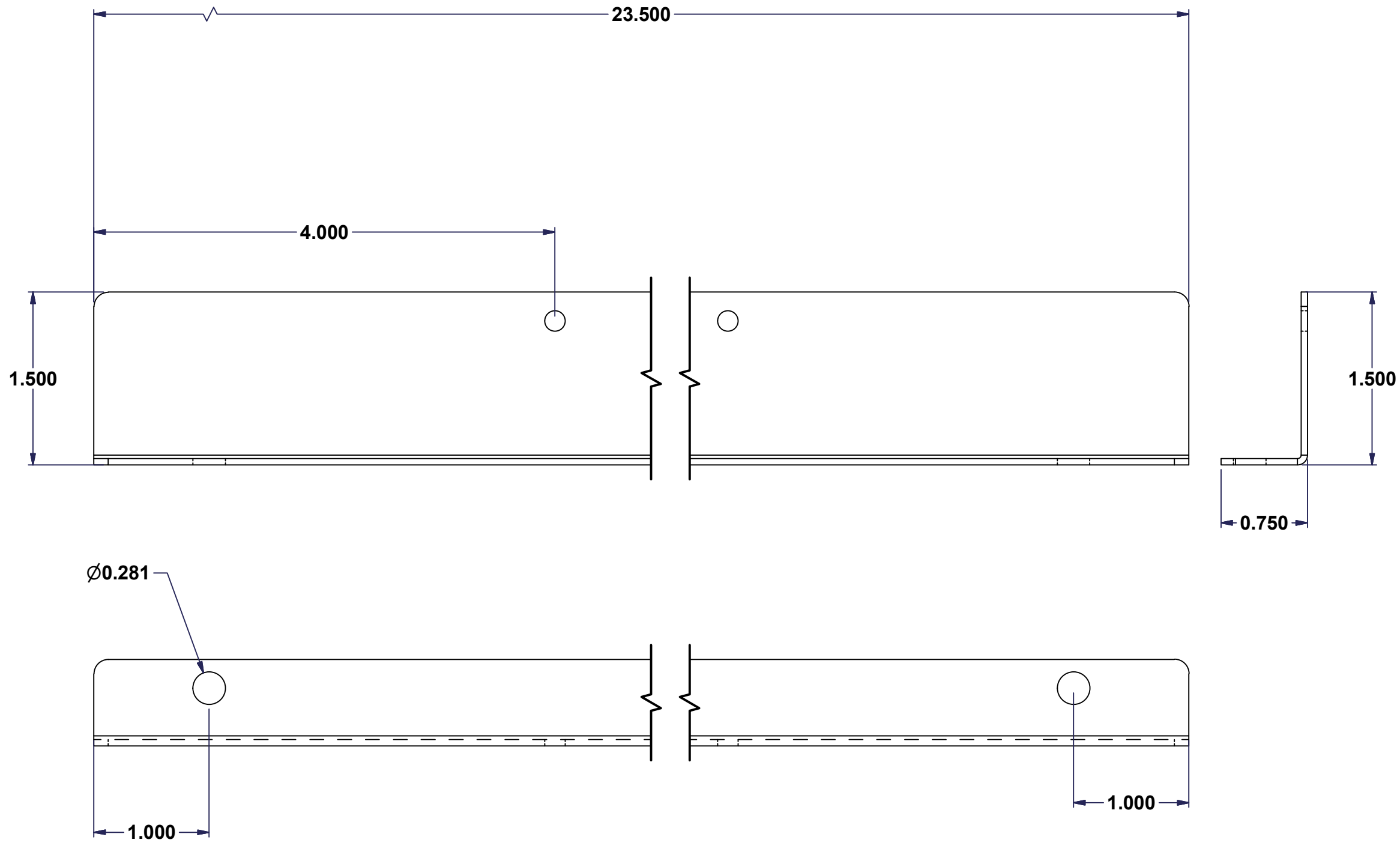

This drawing is confidential and must not be reproduced or used without the consent of EXM

All knockouts are actual size / Les disques défonçables sont grandeur réel  
 All dimensions are before paint / Toutes les dimensions sont avant peinture

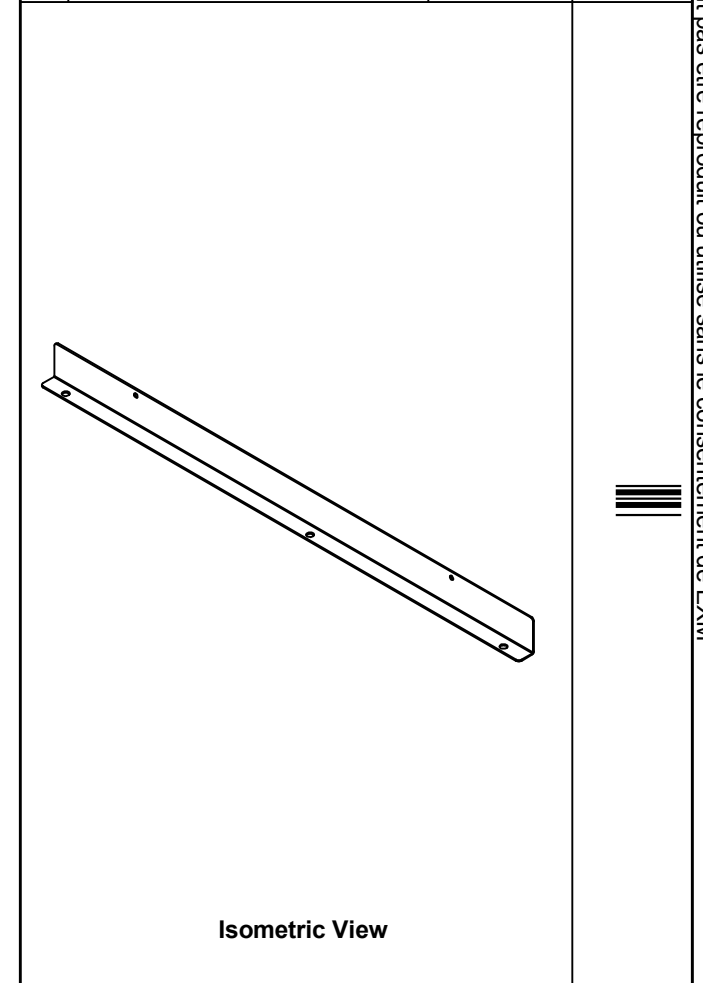

No.	Revisions	Date	By/Par

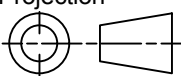

 Tél: (450) 979-4373 Fax: (450) 979-4626 <a href="http://www.exmweb.com">www.exmweb.com</a>		Flatness Aplatissement Max 3.0mm Projection 
Customer Client	Date	
Drawn By Dessiné Par MichaelA	Date 02-Feb-15	
Material Matière	16 Ga H.R.P. & O. (1.4mm)	
Color Couleur	Finish Fini	
Description 1100 Barrier 2.5" High x 24" Long	Detail Rev.	
Part Number Numéro Pièce <b>1100BA2024</b>	Rev.	1
		1

Ce dessin est confidentiel et ne doit pas être reproduit ou utilisé sans le consentement de EXM