

This drawing is confidential and must not be reproduced or used without the consent of EXM

All knockouts are actual size / Les disques défonçables sont grandeur réel
 All dimensions are before paint / Toutes les dimensions sont avant peinture

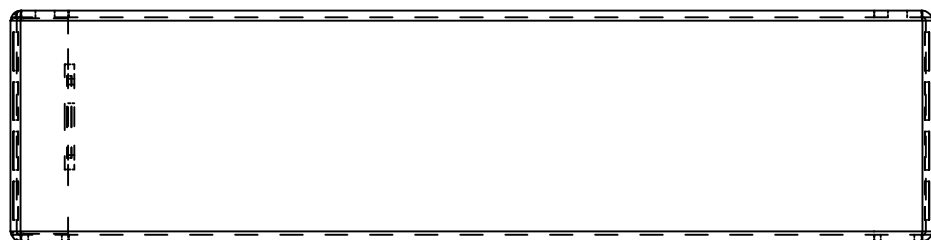

No.	Revisions	Date	By/Par

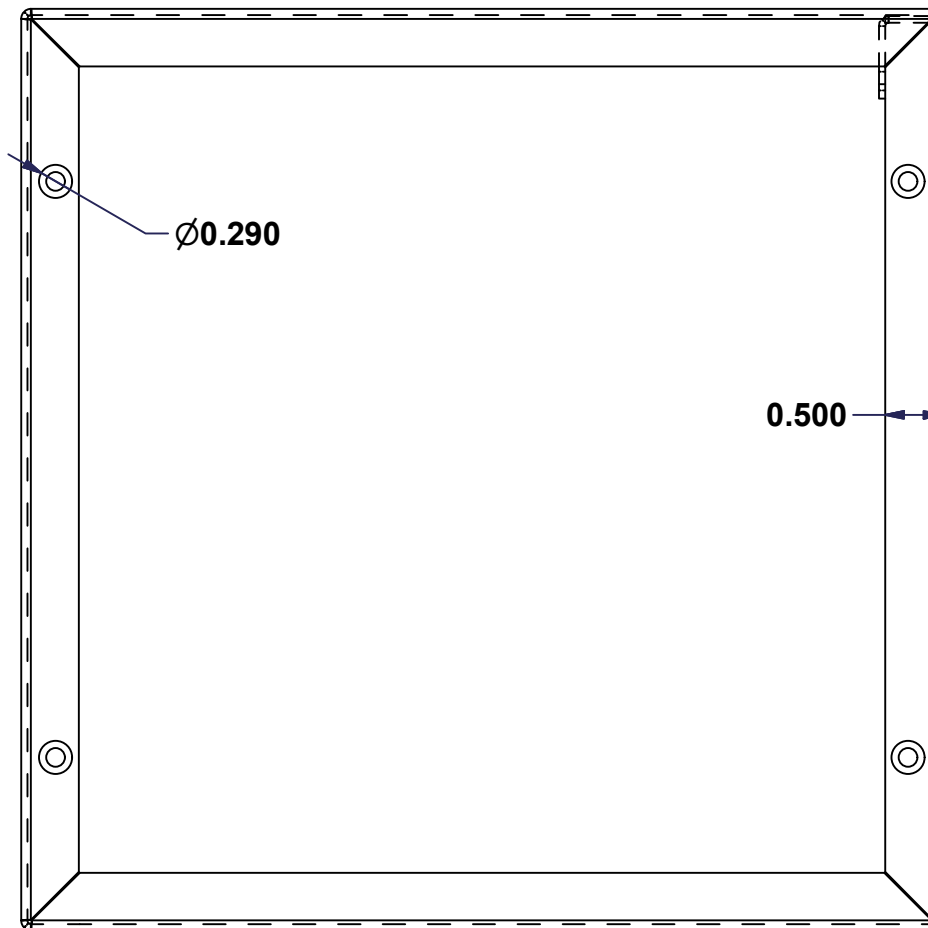
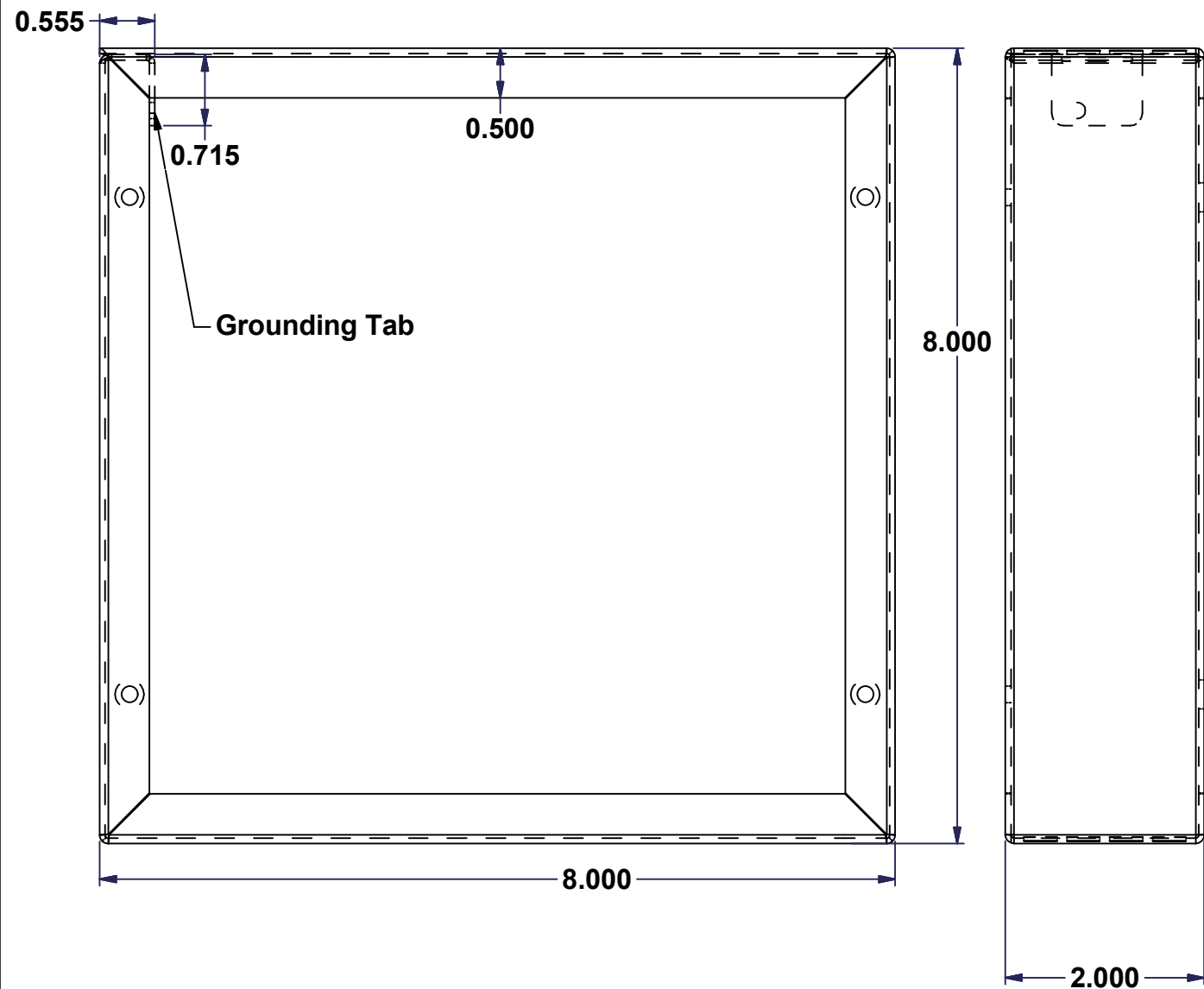
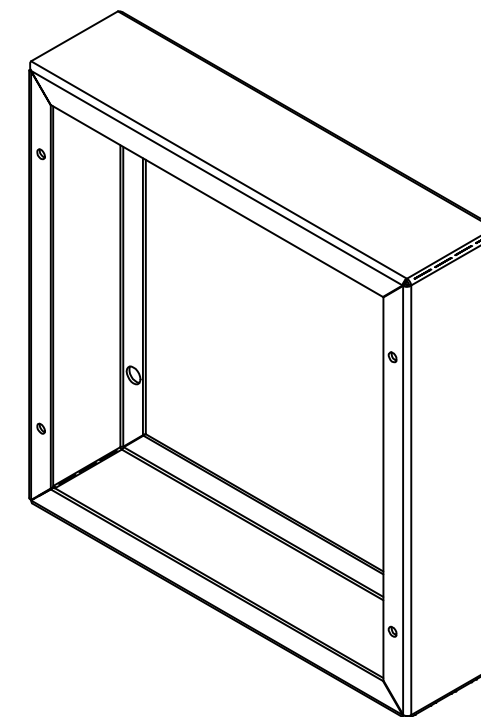

Isometric View

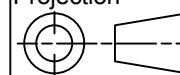

Ce dessin est confidentiel et ne doit pas être reproduit ou utilisé sans le consentement de EXM

 Tél: (450) 979-4373 Fax: (450) 979-4626 www.exmweb.com		Flatness Aplatissement Max 3.0mm Projection 
Customer Client	Date	
Drawn By / Dessiné Par: MichaelA	Date: 06-Feb-15	
Material / Matière: 16 Ga H.R.P. & O. (1.4mm)		
Color / Couleur: ASA 61	Finish / Fini: Painted	
Description: Pull Box Extension Ring 08" x 08" x 02"	Detail Rev.: 0	
Part Number / Numéro Pièce: 1100DER080802	Rev.: 0	1 / 1