

All knockouts are actual size / Les disques défonçables sont grandeur réel
 All dimensions are before paint / Toutes les dimensions sont avant peinture

This drawing is confidential and must not be reproduced or used without the consent of EXM

Ce dessin est confidentiel et ne doit pas être reproduit ou utilisé sans le consentement de EXM

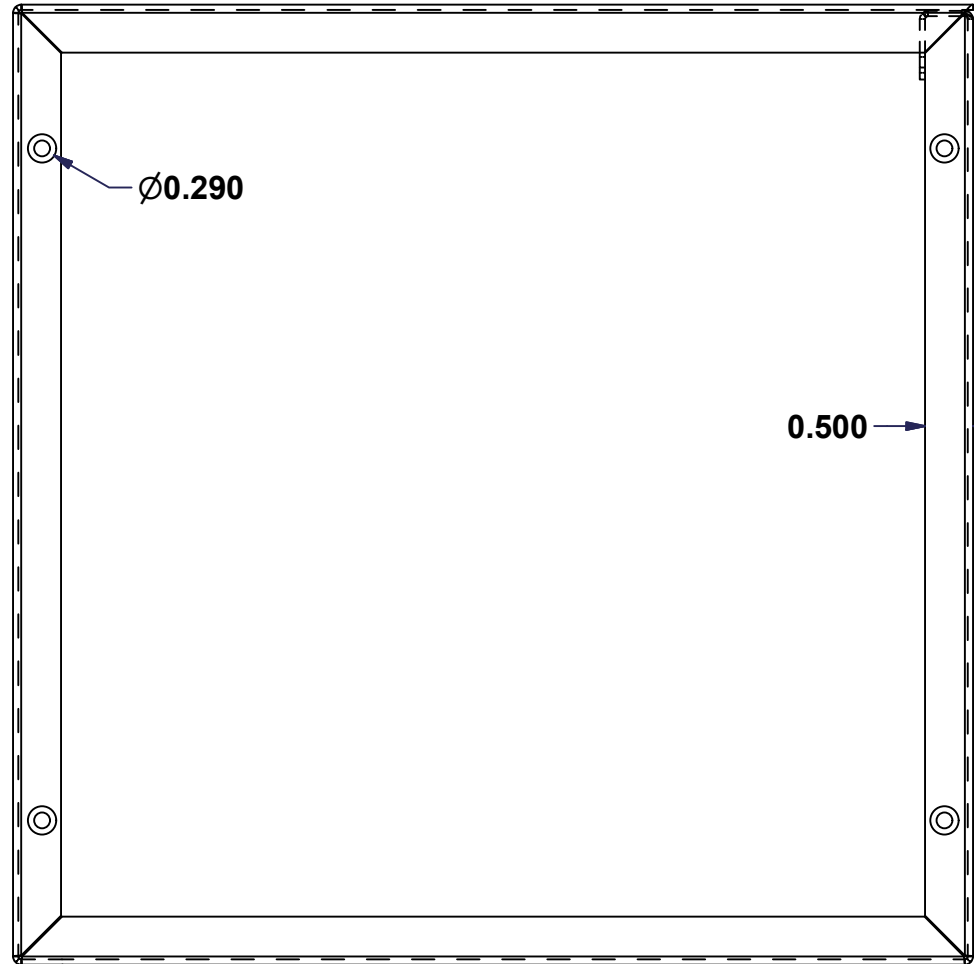
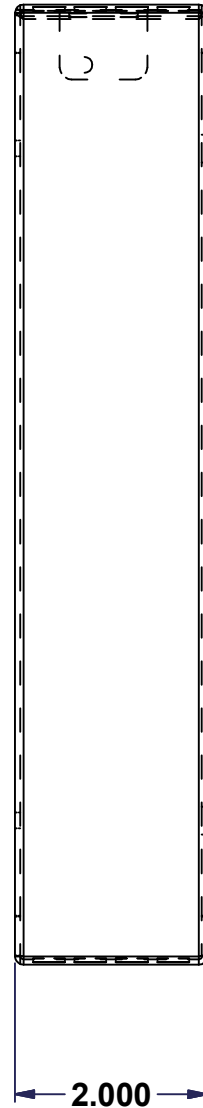
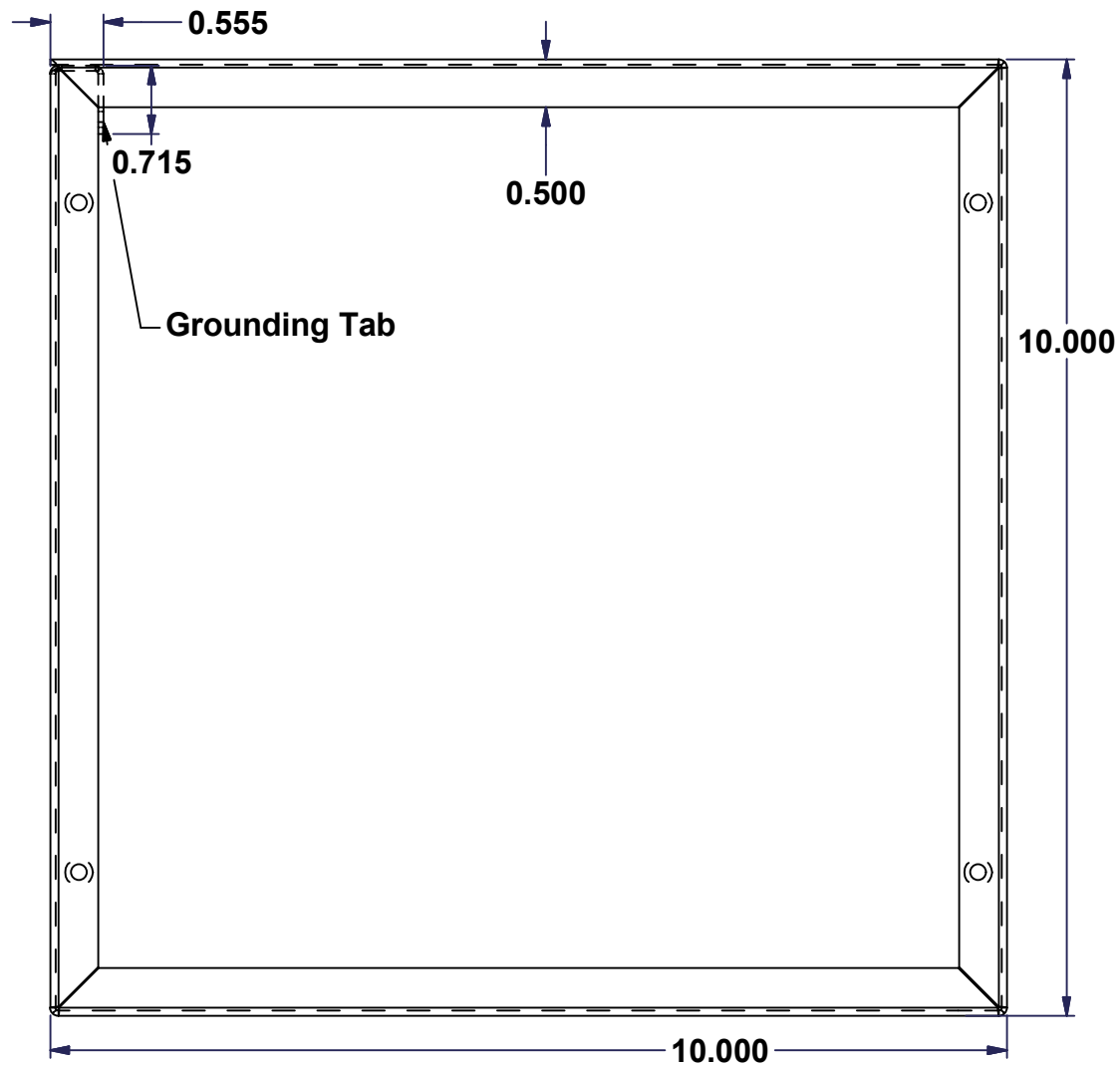

No.	Revisions	Date	By/Par

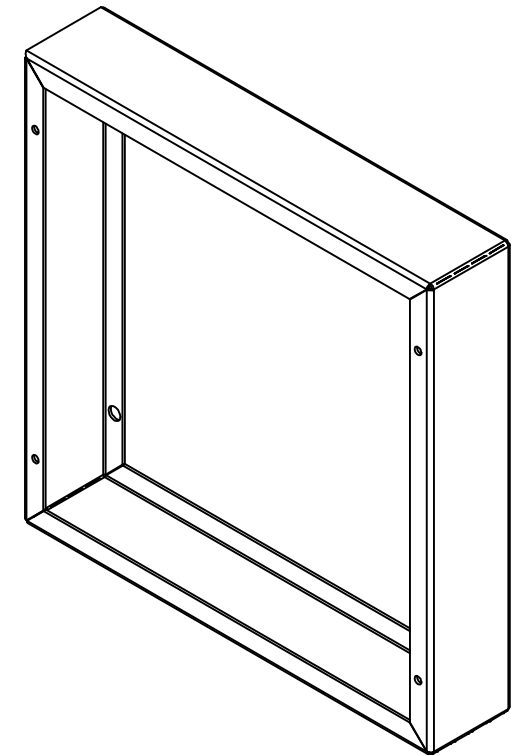

Isometric View



Tél: (450) 979-4373
 Fax: (450) 979-4626
www.exmweb.com

Flatness
 Aplatissement
 Max 3.0mm
 Projection

Customer Client	Date
Drawn By Dessiné Par MichaelA	Date 06-Feb-15
Material Matière 16 Ga H.R.P. & O. (1.4mm)	
Color Couleur ASA 61	Finish Fini Painted
Description Pull Box Extension Ring 10" x 10" x 02"	Detail Rev. 0
Part Number Numéro Pièce 1100DER101002	Rev. 0

1
1