

All knockouts are actual size / Les disques défonçables sont grandeur réel
 All dimensions are before paint / Toutes les dimensions sont avant peinture

This drawing is confidential and must not be reproduced or used without the consent of EXM

Ce dessin est confidentiel et ne doit pas être reproduit ou utilisé sans le consentement de EXM

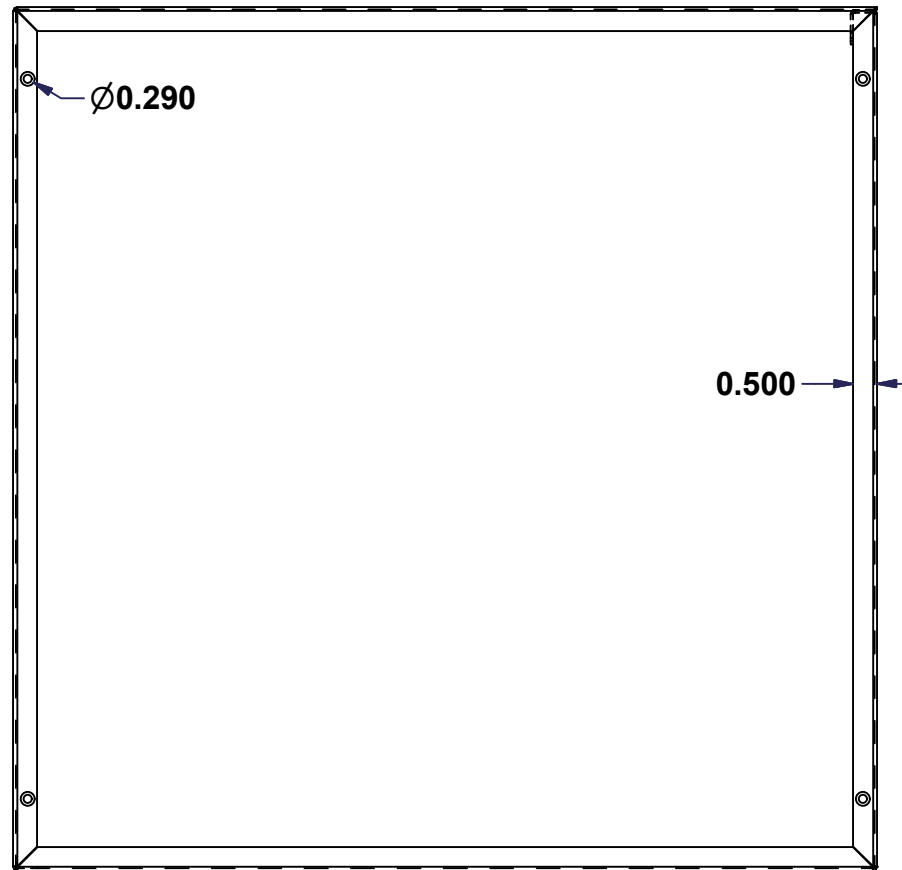
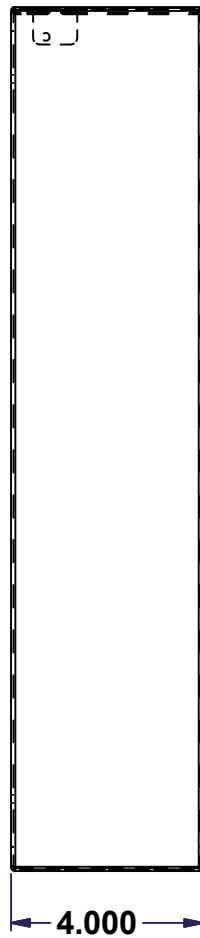
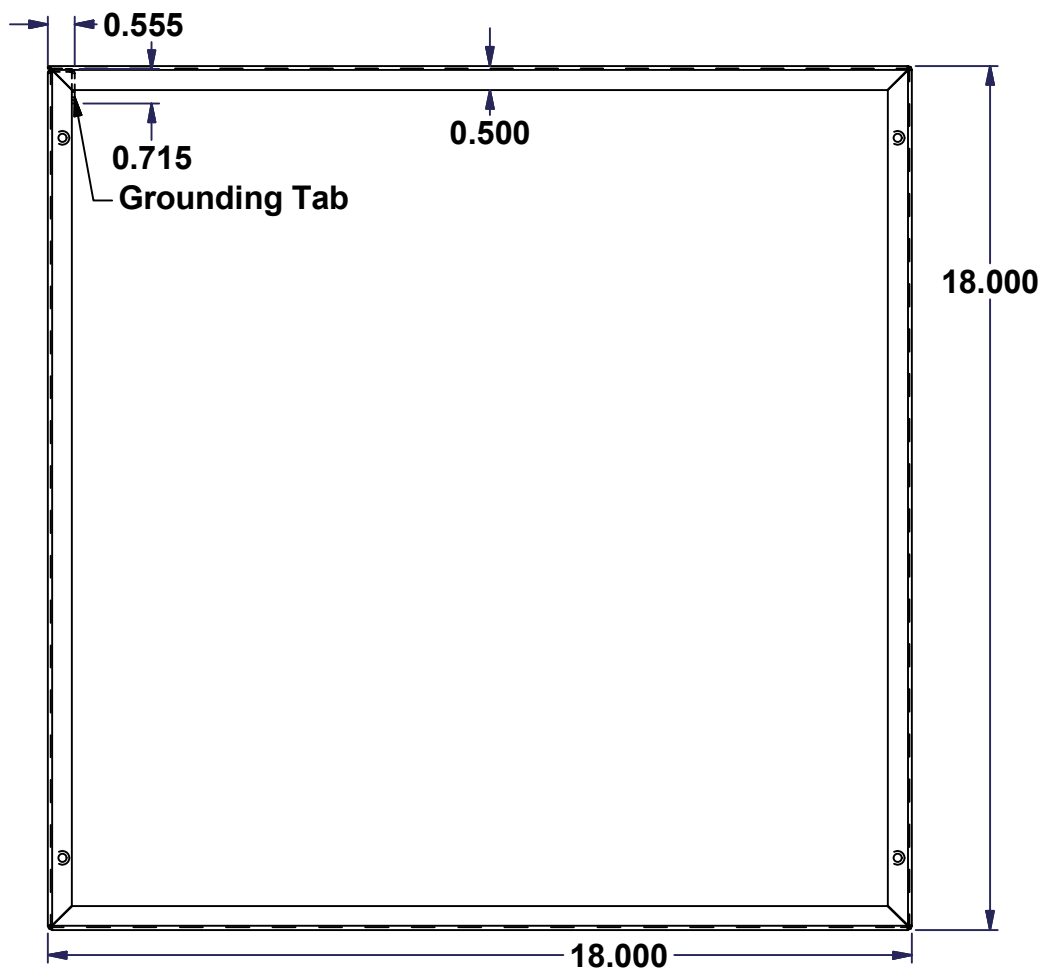
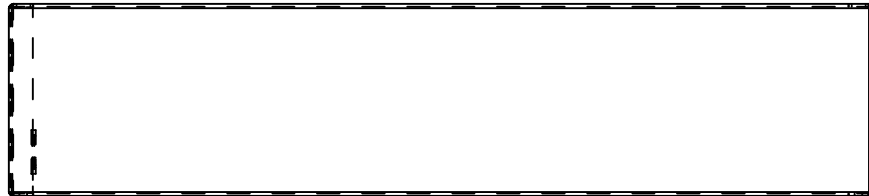

No.	Revisions	Date	By/Par

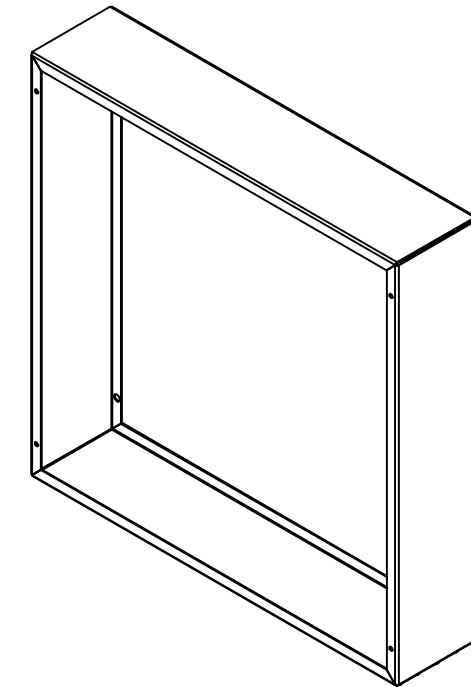

Isometric View



Tél: (450) 979-4373
 Fax: (450) 979-4626
www.exmweb.com

Flatness
 Aplatissement

Max 3.0mm

Projection

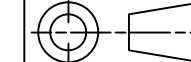

Customer Client	Date
Drawn By / Dessiné Par: MichaelA	Date: 06-Feb-15
Material / Matière: 16 Ga H.R.P. & O. (1.4mm)	
Color / Couleur: ASA 61	Finish / Fini: Painted
Description: Pull Box Extension Ring 18" x 18" x 04"	Detail Rev.: 0
Part Number / Numéro Pièce: 1100DER181804	Rev.: 0

1
 1