

This drawing is confidential and must not be reproduced or used without the consent of EXM

Ce dessin est confidentiel et ne doit pas être reproduit ou utilisé sans le consentement de EXM

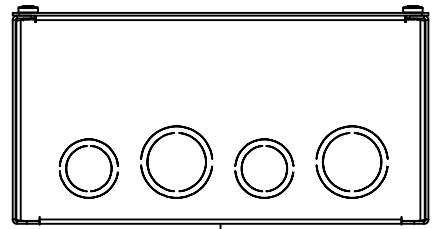

TOP

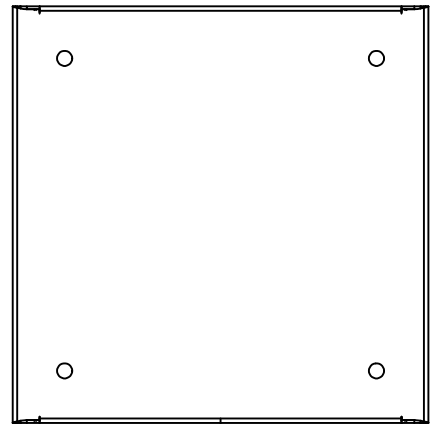

BACK

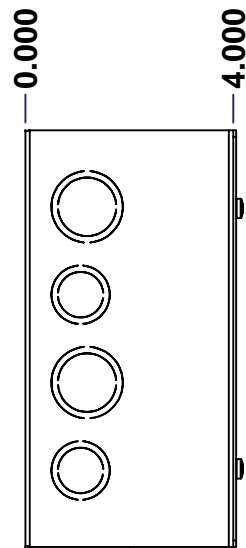

LEFT

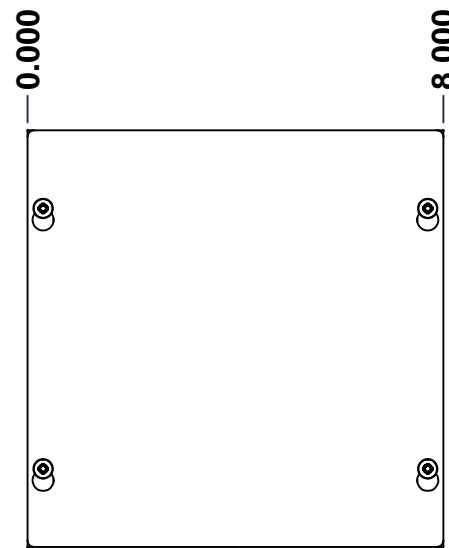

FRONT

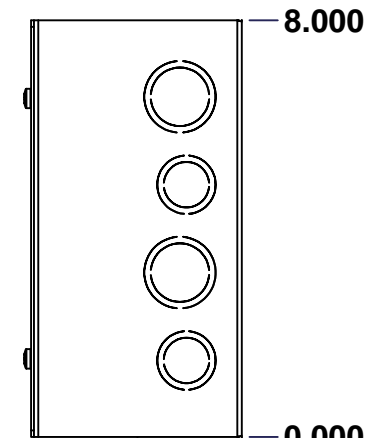

RIGHT

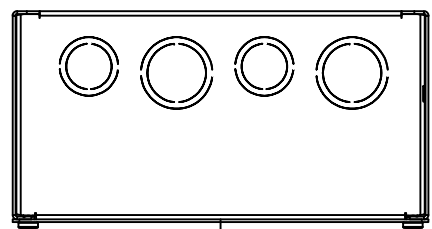

BOTTOM

| No. | Revisions | Date | By/Par |
|-----|-----------|------|--------|
| | | | |
| | | | |
| | | | |
| | | | |

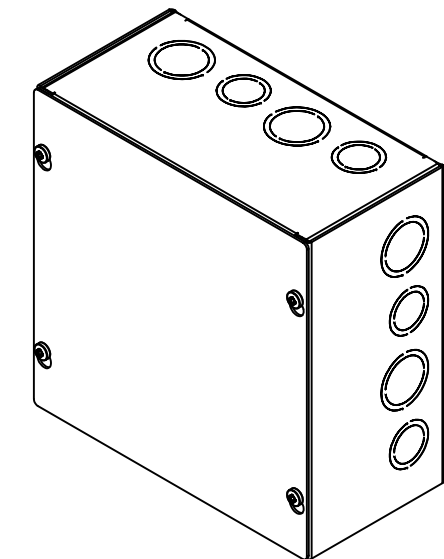

Isometric View



Tél: (450) 979-4373
 Fax: (450) 979-4626
www.exmweb.com

Flatness
Aplatissement

Max 3.0mm

Projection

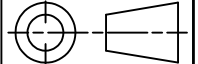

| | |
|---|-----------------------|
| Customer Client | Date |
| Drawn By / Dessiné Par: BoxCad: BoxCad | Date: 22-Jun-17 |
| Material / Matière: 16 Ga H.R.P. & O. (1.4mm) | |
| Color / Couleur: Asa-61 Grey | Finish / Fini: Smooth |
| Description: 1100DF 8" x 8" x 4" Assembly | Detail Rev. |
| Part Number / Numéro Pièce: 1100DF080804 | Rev. 0 |

SEE BILL OF MATERIAL ON LAST PAGE

| |
|---|
| 1 |
| 2 |

This drawing is confidential and must not be reproduced or used without the consent of EXM

Ce dessin est confidentiel et ne doit pas être reproduit ou utilisé sans le consentement de EXM

| NOTE | |
|------|--|
| ITEM | DESCRIPTION |
| 1 | NEMA 1 Enclosure |
| 2 | C/W Standard ground provision on box and cover |
| 3 | W/O Standard door stiffener |
| 4 | W/O Inner panel |
| 5 | W/O Inner panel mounting provision |

| No. | Revisions | Date | By/Par |
|-----|-----------|------|--------|
| | | | |
| | | | |
| | | | |
| | | | |
| | | | |
| | | | |

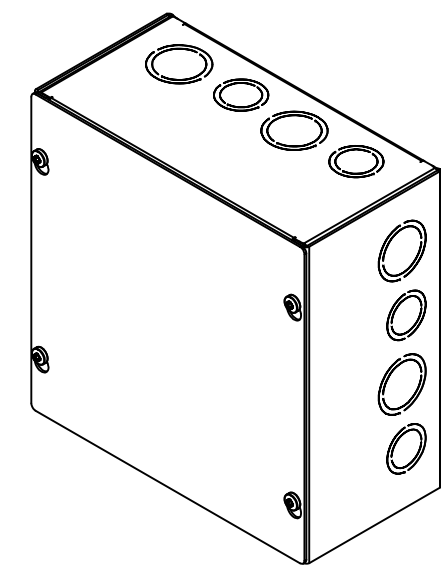

Isometric View



Tél: (450) 979-4373
 Fax: (450) 979-4626
www.exmweb.com

Flatness
Aplatissement
Max 3.0mm
Projection

| | |
|---|-----------------------|
| Customer Client | Date |
| Drawn By / Dessiné Par: BoxCad: BoxCad | Date: 22-Jun-17 |
| Material / Matière: 16 Ga H.R.P. & O. (1.4mm) | |
| Color / Couleur: Asa-61 Grey | Finish / Fini: Smooth |

| PACKING | | |
|----------------------|-----|---|
| ITEM | QTY | DESCRIPTION |
| Thermal plastic film | 1 | Use with Packing Tunnel Wrapper Machine |
| Packaging label | 1 | White label with product number |

| Qty | Part Number | Rev | Description |
|------------|---------------|-----|-------------------------------|
| 4 | STK-Q-05020 | 5 | M5 x 8mm Thread Rolling Screw |
| 1 | 1100DF080804C | 0 | 1100DF 8" x 8" Cover |
| 1 | 1100DF080804B | 0 | 1100DF 8" x 8" x 4" Body |
| Parts List | | | |

| | |
|---|-------------|
| Description: 1100DF 8" x 8" x 4" Assembly | Detail Rev. |
| Part Number / Numéro Pièce: 1100DF080804 | Rev. 0 / 2 |

This drawing is confidential and must not be reproduced or used without the consent of EXM

Ce dessin est confidentiel et ne doit pas être reproduit ou utilisé sans le consentement de EXM

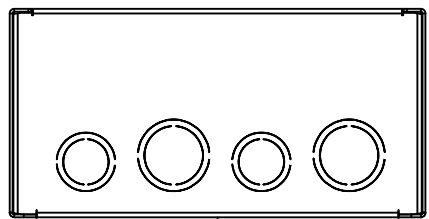

TOP

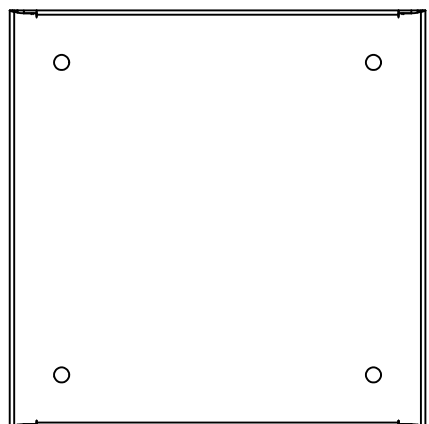

BACK

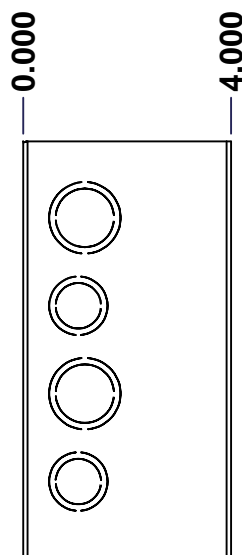

LEFT

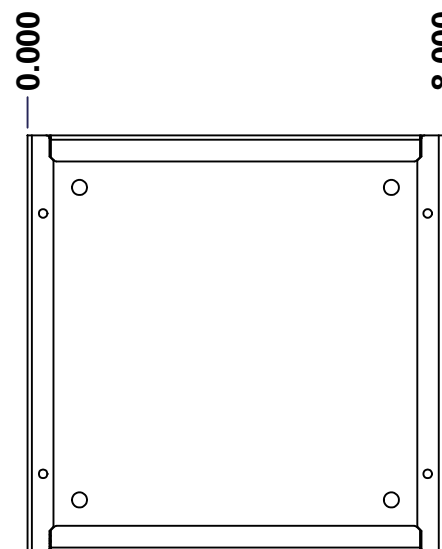

FRONT

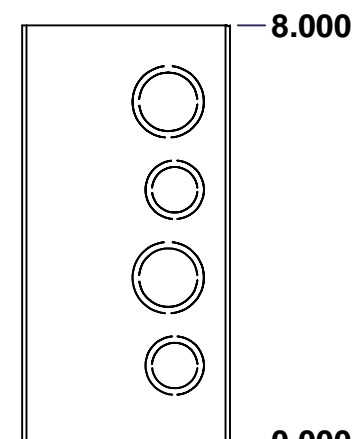

RIGHT

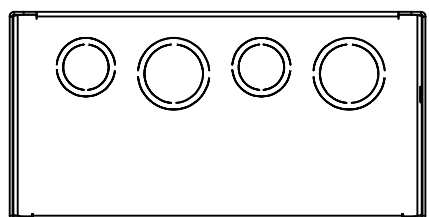

BOTTOM

| No. | Revisions | Date | By/Par |
|-----|-----------|------|--------|
| | | | |
| | | | |
| | | | |
| | | | |
| | | | |

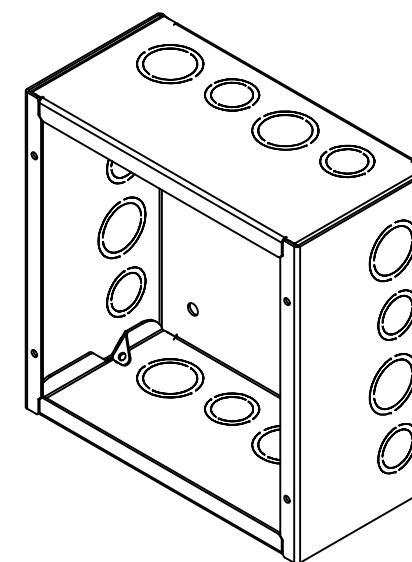

Isometric View



Tél: (450) 979-4373
 Fax: (450) 979-4626
www.exmweb.com

Flatness
Aplatissement

Max 3.0mm

Projection

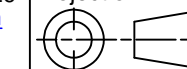

| | |
|---|-----------------------|
| Customer Client | Date |
| Drawn By / Dessiné Par: BoxCad: BoxCad | Date: 22-Jun-17 |
| Material / Matière: 16 Ga H.R.P. & O. (1.4mm) | |
| Color / Couleur: Asa-61 Grey | Finish / Fini: Smooth |
| Description: 1100DF 8" x 8" x 4" Body | |
| Detail Rev. | |
| Part Number / Numéro Pièce: 1100DF080804B | Rev. 0 |

SEE BILL OF MATERIAL ON LAST PAGE

1
7

This drawing is confidential and must not be reproduced or used without the consent of EXM

Ce dessin est confidentiel et ne doit pas être reproduit ou utilisé sans le consentement de EXM

STANDARD FEATURES ARE NOT LISTED IN THIS HOLE TABLE

HOLE TABLE - BACK VIEW (CUSTOM FEATURE ONLY)

| CUT-OUT | XDIM | YDIM | DESCRIPTION |
|---------|-------|-------|-------------|
| 1 | 7.000 | 1.000 | RND Ø0.290 |
| 2 | 7.000 | 7.000 | RND Ø0.290 |
| 3 | 1.000 | 7.000 | RND Ø0.290 |
| 4 | 1.000 | 1.000 | RND Ø0.290 |

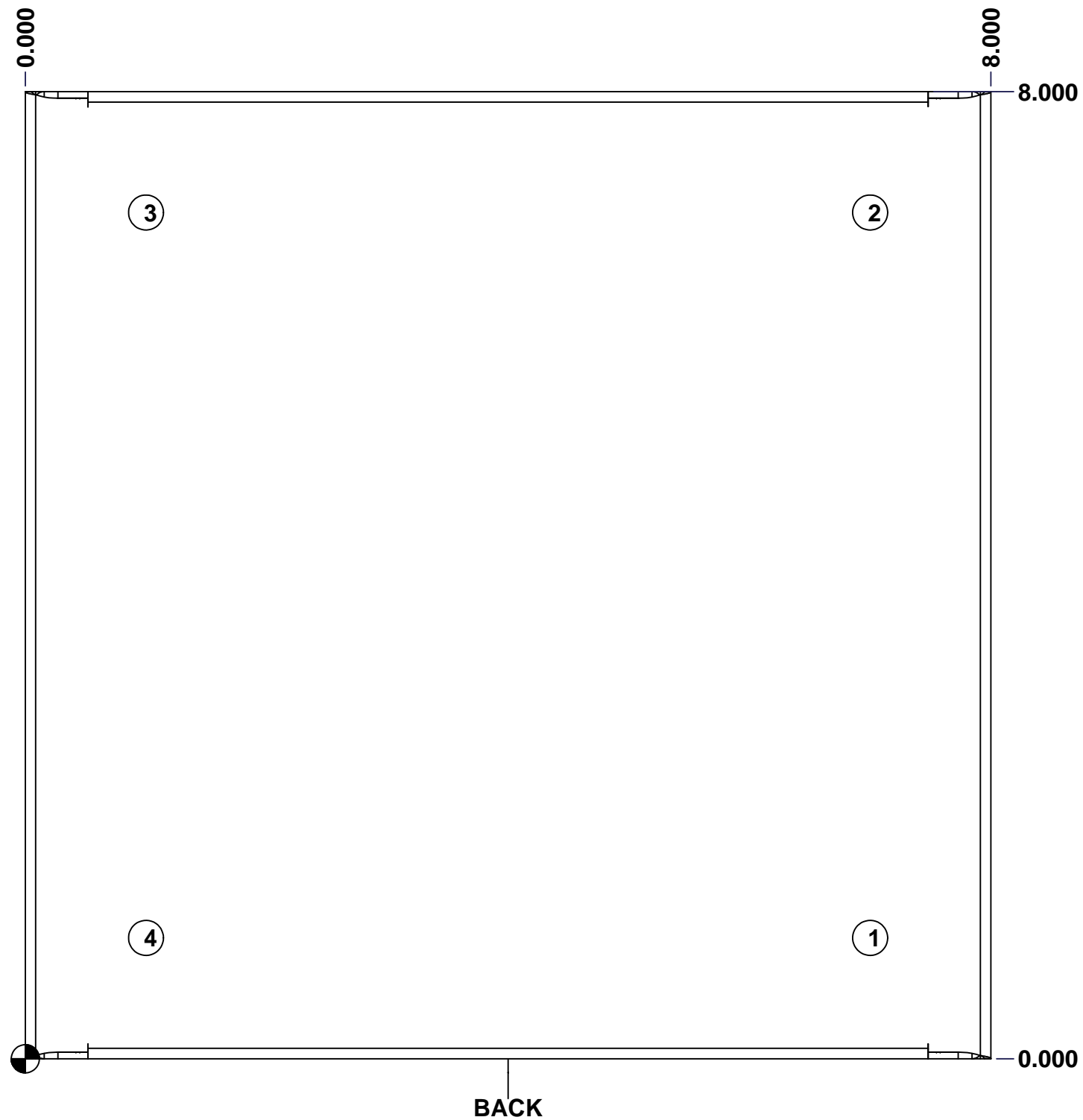

| | | | |
|--|-----------------------------|----------|--------|
| | Description | Status | |
| | 1100DF 8" x 8" x 4" Body | (NULL) | |
| | Part Number Numéro Pièce | Rev. | |
| | 1100DF080804B | 0 | 6 7 |

This drawing is confidential and must not be reproduced or used without the consent of EXM

Ce dessin est confidentiel et ne doit pas être reproduit ou utilisé sans le consentement de EXM

| No. | Revisions | Date | By/Par |
|-----|-----------|------|--------|
| | | | |
| | | | |
| | | | |
| | | | |
| | | | |

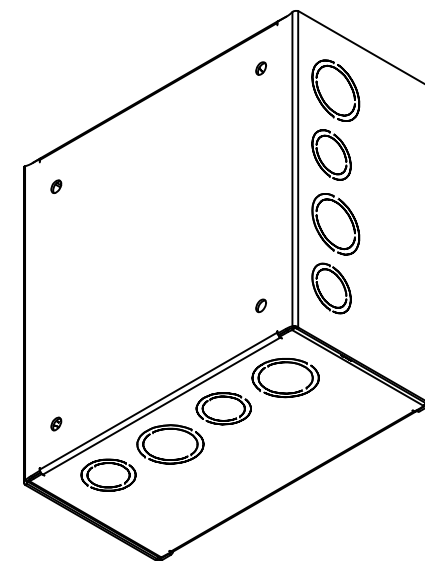

Isometric View

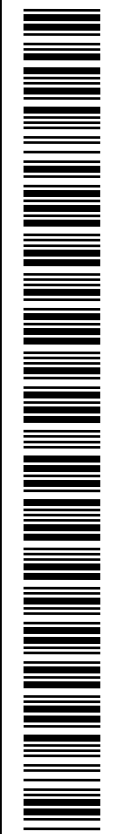

Tél: (450) 979-4373
 Fax: (450) 979-4626
www.exmweb.com

Flatness
Aplatissement
Max 3.0mm
Projection

| | |
|---|-----------------------|
| Customer Client | Date |
| Drawn By / Dessiné Par: BoxCad: BoxCad | Date: 22-Jun-17 |
| Material / Matière: 16 Ga H.R.P. & O. (1.4mm) | |
| Color / Couleur: Asa-61 Grey | Finish / Fini: Smooth |

| Qty | Part Number | Rev | Description |
|------------|-----------------|-----|-------------------------------------|
| 1 | STK-P-02400S | 0 | Powder Paint (Asa-61 Grey / Smooth) |
| 1 | 1100DF080804B-P | 0 | 1100DF 8" x 8" x 4" Body Part |
| Parts List | | | |

| | |
|--|-------------|
| Description: 1100DF 8" x 8" x 4" Body | Detail Rev. |
| Part Number / Numéro Pièce: 1100DF080804B | Rev. 0 / 7 |

This drawing is confidential and must not be reproduced or used without the consent of EXM

Ce dessin est confidentiel et ne doit pas être reproduit ou utilisé sans le consentement de EXM

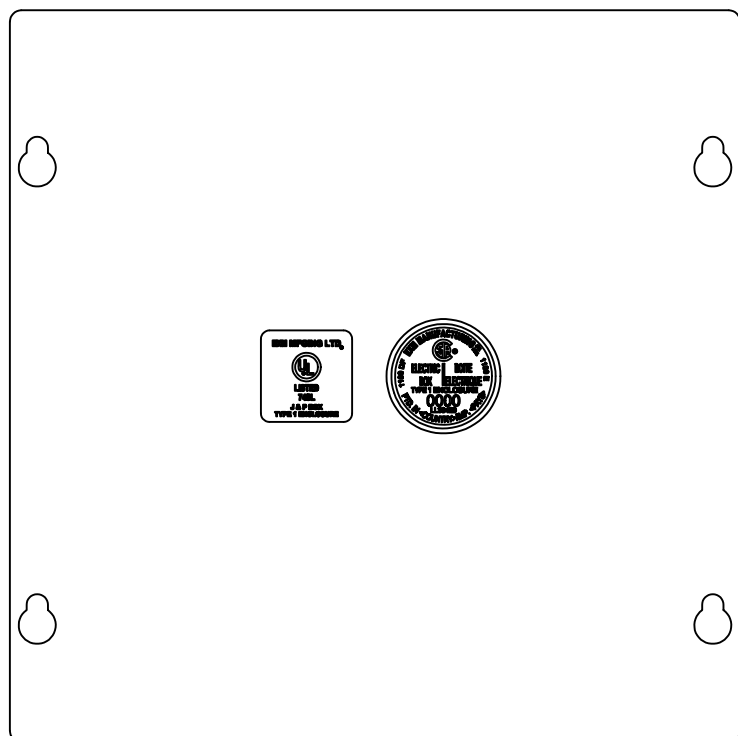
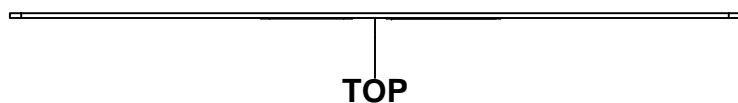

BACK



LEFT

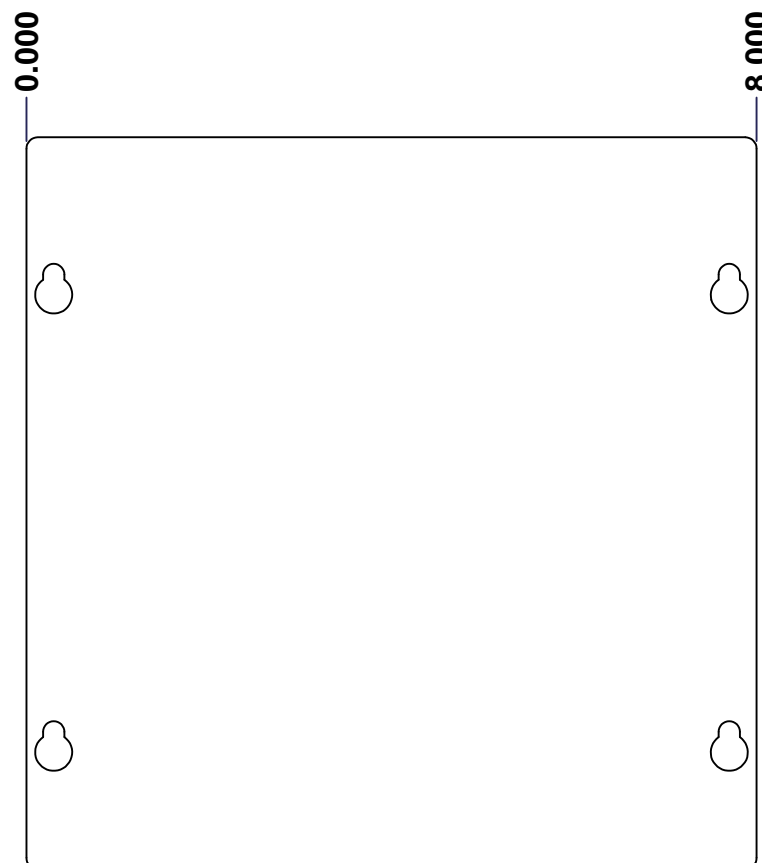

FRONT

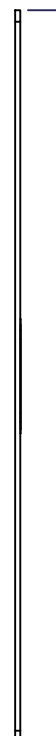

RIGHT



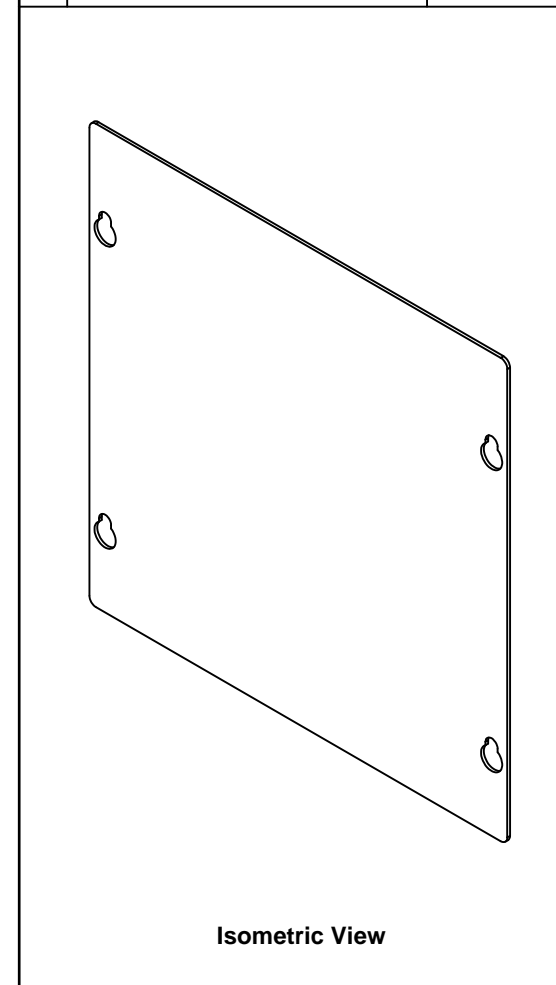

BOTTOM

| No. | Revisions | Date | By/Par |
|-----|-----------|------|--------|
| | | | |
| | | | |
| | | | |
| | | | |
| | | | |



Isometric View



| | | |
|--|---------------------------|---|
|  Tél: (450) 979-4373 Fax: (450) 979-4626 www.exmweb.com | | Flatness Aplatissement Max 3.0mm Projection  |
| Customer Client | Date | |
| Drawn By Dessiné Par | BoxCad: BoxCad | Date 22-Jun-17 |
| Material Matière | 16 Ga H.R.P. & O. (1.4mm) | |
| Color Couleur | Asa-61 Grey | Finish Fini Smooth |
| Description | Detail Rev. | |
| 1100DF 8" x 8" Cover | | |
| Part Number Numéro Pièce | Rev. 0 | 1 3 |
| 1100DF080804C | | |

SEE BILL OF MATERIAL ON LAST PAGE

This drawing is confidential and must not be reproduced or used without the consent of EXM

Ce dessin est confidentiel et ne doit pas être reproduit ou utilisé sans le consentement de EXM

| No. | Revisions | Date | By/Par |
|-----|-----------|------|--------|
| | | | |
| | | | |
| | | | |
| | | | |
| | | | |

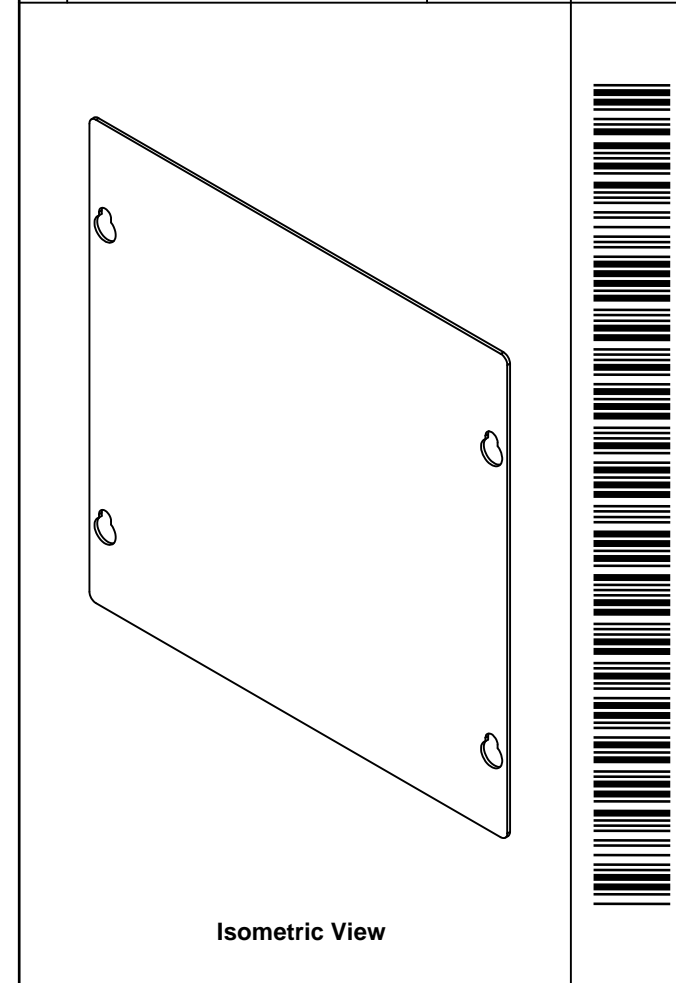

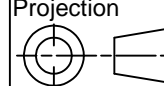
| | | |
|--|---------------------------|---|
|  Tél: (450) 979-4373 Fax: (450) 979-4626 www.exmweb.com | | Flatness Aplatissement Max 3.0mm Projection  |
| Customer Client | Date | |
| Drawn By Dessiné Par | BoxCad: BoxCad | Date 22-Jun-17 |
| Material Matière | 16 Ga H.R.P. & O. (1.4mm) | |
| Color Couleur | Asa-61 Grey | Finish Fini Smooth |
| Description | | Detail Rev. |
| 1100DF 8" x 8" Cover | | |
| Part Number Numéro Pièce | Rev. | 3 |
| 1100DF080804C | 0 | 3 |

| Qty | Part Number | Rev | Description |
|------------|-----------------|-----|-------------------------------------|
| 1 | STK-S-00950 | 1 | UL 74SL Pull-Box Sticker |
| 1 | STK-S-00800 | 2 | CSA Electrical Box Sticker |
| 1 | 1100DF080804C-P | 0 | 1100DF 8" x 8" Cover Part |
| 1 | STK-P-02400S | 0 | Powder Paint (Asa-61 Grey / Smooth) |
| Parts List | | | |