

This drawing is confidential and must not be reproduced or used without the consent of EXM

Ce dessin est confidentiel et ne doit pas être reproduit ou utilisé sans le consentement de EXM

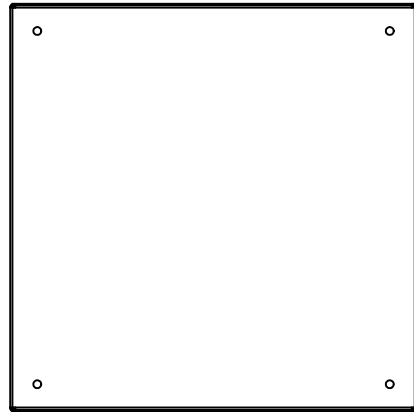

TOP



BACK

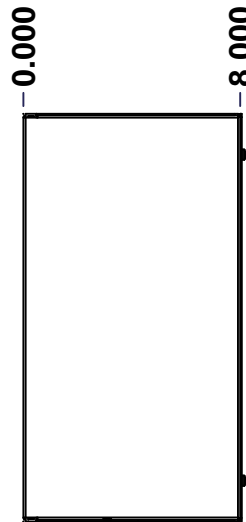

LEFT

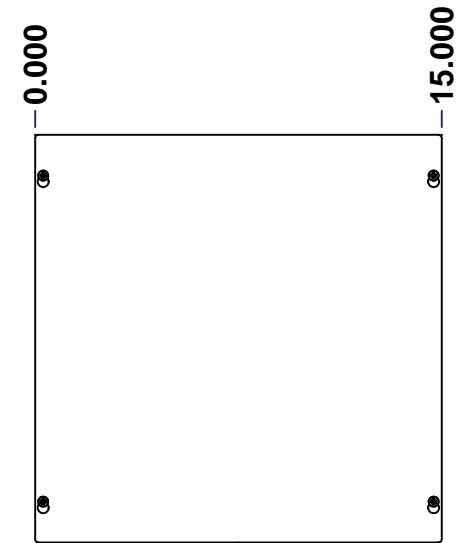

FRONT

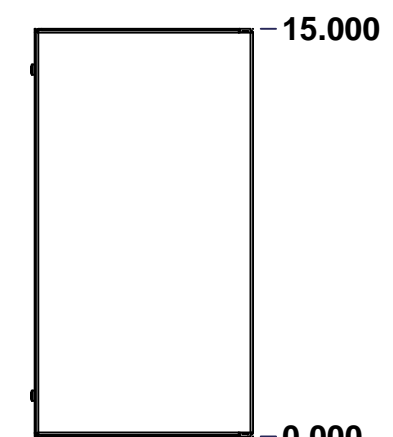

RIGHT



BOTTOM

| No. | Revisions | Date | By/Par |
|-----|-----------|------|--------|
|     |           |      |        |
|     |           |      |        |
|     |           |      |        |
|     |           |      |        |
|     |           |      |        |

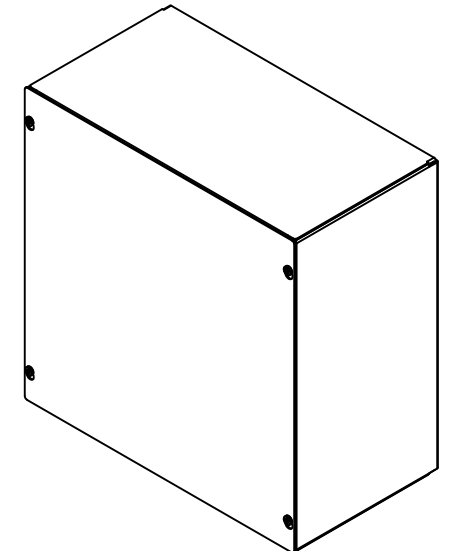

Isometric View



Tél: (450) 979-4373  
 Fax: (450) 979-4626  
[www.exmweb.com](http://www.exmweb.com)

Flatness  
Aplatissement  
Max 3.0mm  
Projection

|   |                       |
|---|-----------------------|
| Customer Client                               | Date                  |
| Drawn By / Dessiné Par: BoxCad: BoxCad        | Date: 15-Oct-13       |
| Material / Matière: 16 Ga H.R.P. & O. (1.4mm) |                       |
| Color / Couleur: Asa-61 Grey                  | Finish / Fini: Smooth |
| Description: 1100DFN 15" x 15" x 8" Assembly  | Detail Rev.           |

|  |               |        |
|--|---------------|--------|
| Part Number / Numéro Pièce: <b>1100DF151508N</b> | Rev. <b>0</b> | 1<br>2 |
|--|---------------|--------|

SEE BILL OF MATERIAL ON LAST PAGE

This drawing is confidential and must not be reproduced or used without the consent of EXM

Ce dessin est confidentiel et ne doit pas être reproduit ou utilisé sans le consentement de EXM

| NOTE |  |
|------|--|
| ITEM | DESCRIPTION                                    |
| 1    | NEMA 1 Enclosure                               |
| 2    | C/W Standard ground provision on box and cover |
| 3    | W/O Standard door stiffener                    |
| 4    | W/O Inner panel                                |
| 5    | W/O Inner panel mounting provision             |

| No. | Revisions | Date | By/Par |
|-----|-----------|------|--------|
|     |           |      |        |
|     |           |      |        |
|     |           |      |        |
|     |           |      |        |
|     |           |      |        |
|     |           |      |        |

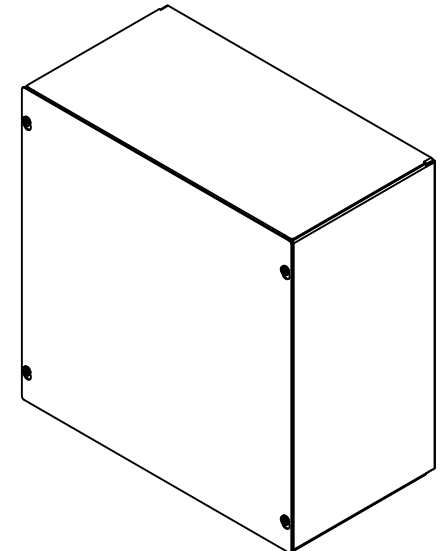

Isometric View

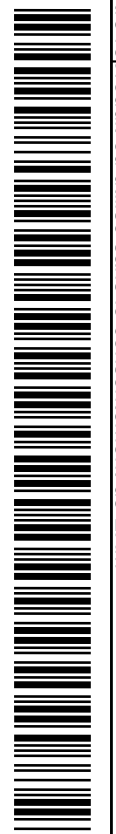

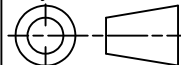
|  |                                 |   |
|--|---------------------------------|---|
|  Tél: (450) 979-4373<br>Fax: (450) 979-4626<br><a href="http://www.exmweb.com">www.exmweb.com</a> |                                 | Flatness<br>Aplatissement<br>Max 3.0mm<br>Projection<br> |
| Customer Client  | Date                            |   |
| Drawn By<br>Dessiné Par  | BoxCad: BoxCad                  | Date 15-Oct-13  |
| Material<br>Matière  | 16 Ga H.R.P. & O. (1.4mm)       |   |
| Color<br>Couleur   | Asa-61 Grey                     | Finish<br>Fini Smooth   |
| Description  | 1100DFN 15" x 15" x 8" Assembly | Detail Rev.   |
| Part Number<br>Numéro Pièce  | <b>1100DF151508N</b>            | Rev. 0  |

| PACKING              |     |   |
|----------------------|-----|---|
| ITEM                 | QTY | DESCRIPTION                             |
| Thermal plastic film | 1   | Use with Packing Tunnel Wrapper Machine |
| Packaging label      | 1   | White label with product number         |

| Qty        | Part Number    | Rev | Description                   |
|------------|----------------|-----|-------------------------------|
| 4          | STK-Q-05020    | 5   | M5 x 8mm Thread Rolling Screw |
| 1          | 1100DF151508NC | 0   | 1100DFN 15" x 15" Cover       |
| 1          | 1100DF151508NB | 0   | 1100DFN 15" x 15" x 8" Body   |
| Parts List |                |     |                               |

This drawing is confidential and must not be reproduced or used without the consent of EXM

Ce dessin est confidentiel et ne doit pas être reproduit ou utilisé sans le consentement de EXM

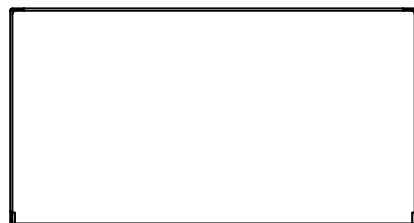

TOP

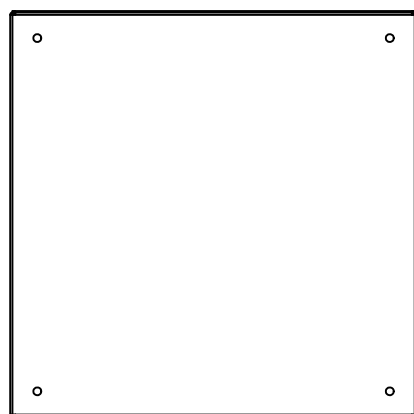

BACK

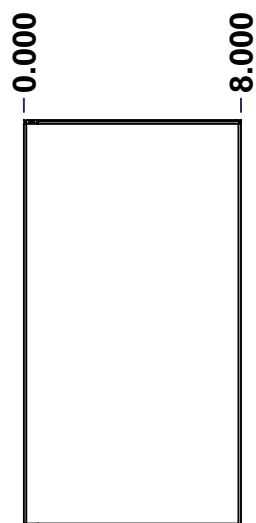

LEFT

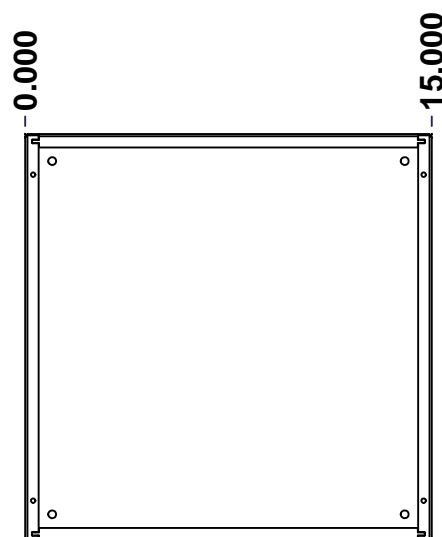

FRONT

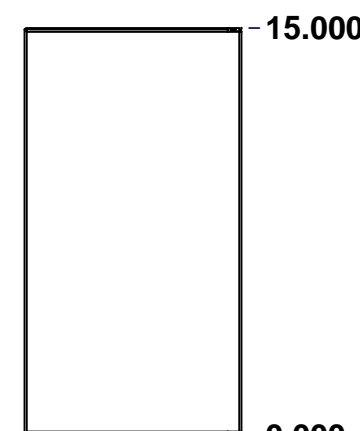

RIGHT

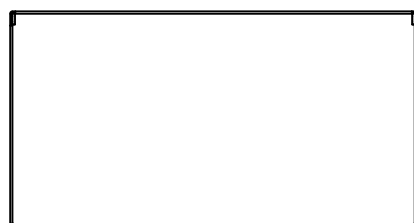

BOTTOM

| No. | Revisions | Date | By/Par |
|-----|-----------|------|--------|
|     |           |      |        |
|     |           |      |        |
|     |           |      |        |
|     |           |      |        |
|     |           |      |        |

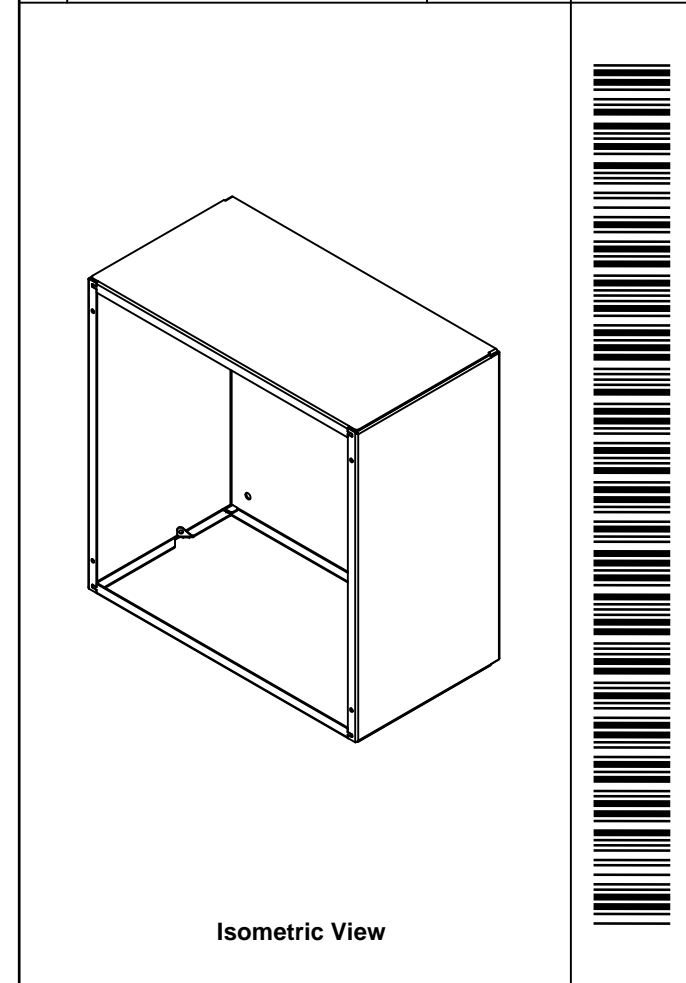

Isometric View

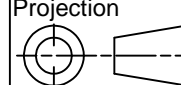

|  |                           |   |
|--|---------------------------|---|
|  Tél: (450) 979-4373<br>Fax: (450) 979-4626<br><a href="http://www.exmweb.com">www.exmweb.com</a> |                           | Flatness<br>Aplatissement<br>Max 3.0mm<br>Projection<br> |
| Customer<br>Client   | Date                      |   |
| Drawn By<br>Dessiné Par  | BoxCad: BoxCad            | Date 15-Oct-13  |
| Material<br>Matière  | 16 Ga H.R.P. & O. (1.4mm) |   |
| Color<br>Couleur   | Asa-61 Grey               | Finish<br>Fini Smooth   |
| Description  | Detail Rev.               |   |
| 1100DFN 15" x 15" x 8" Body  |                           |   |
| Part Number<br>Numéro Pièce  | Rev. 0                    | 1 / 7   |
| <b>1100DF151508NB</b>  |                           |   |

SEE BILL OF MATERIAL ON LAST PAGE

This drawing is confidential and must not be reproduced or used without the consent of EXM

Ce dessin est confidentiel et ne doit pas être reproduit ou utilisé sans le consentement de EXM

| STANDARD FEATURES ARE NOT LISTED IN THIS HOLE TABLE |        |        |             |
|---|--------|--------|-------------|
| HOLE TABLE - BACK VIEW (CUSTOM FEATURE ONLY)        |        |        |             |
| CUT-OUT   | XDIM   | YDIM   | DESCRIPTION |
| 1   | 14.000 | 1.000  | RND Ø0.290  |
| 2   | 14.000 | 14.000 | RND Ø0.290  |
| 3   | 1.000  | 14.000 | RND Ø0.290  |
| 4   | 1.000  | 1.000  | RND Ø0.290  |

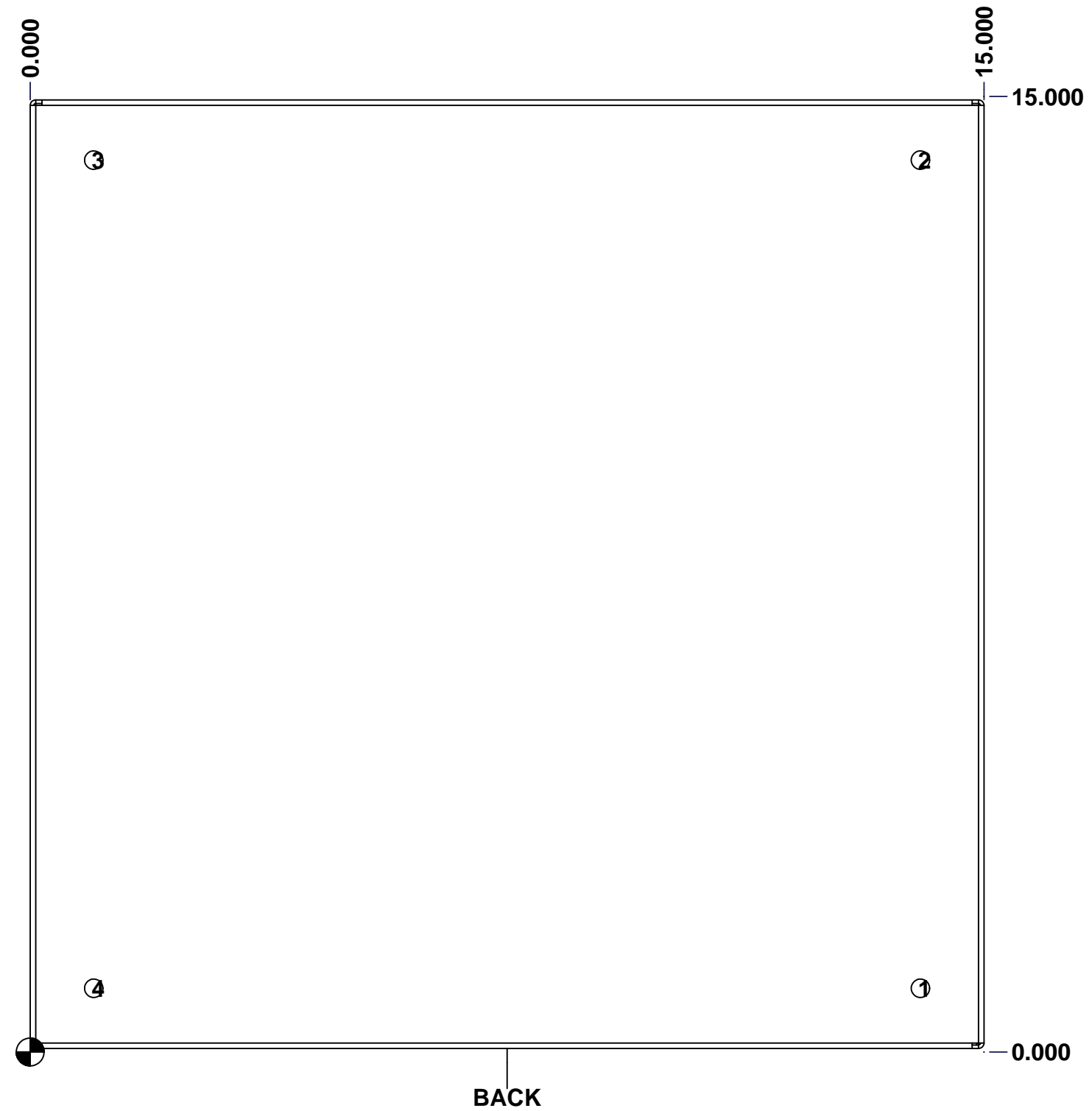

|  |                             |          |        |
|--|-----------------------------|----------|--------|
|  | Description                 | Status   |        |
|  | 1100DFN 15" x 15" x 8" Body | (NULL)   |        |
|  | Part Number<br>Numéro Pièce | Rev.     |        |
|  | <b>1100DF151508NB</b>       | <b>0</b> | 6<br>7 |

This drawing is confidential and must not be reproduced or used without the consent of EXM

Ce dessin est confidentiel et ne doit pas être reproduit ou utilisé sans le consentement de EXM

| No. | Revisions | Date | By/Par |
|-----|-----------|------|--------|
|     |           |      |        |
|     |           |      |        |
|     |           |      |        |
|     |           |      |        |
|     |           |      |        |

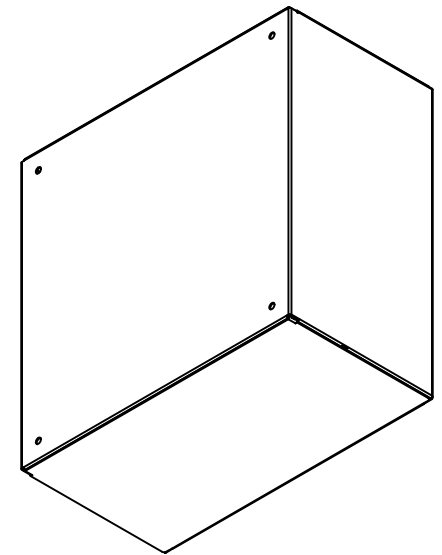

Isometric View

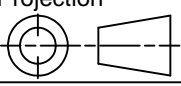

|  |                           |   |
|--|---------------------------|---|
|  Tél: (450) 979-4373<br>Fax: (450) 979-4626<br><a href="http://www.exmweb.com">www.exmweb.com</a> |                           | Flatness<br>Aplatissement<br>Max 3.0mm<br>Projection<br> |
| Customer Client  | Date                      |   |
| Drawn By<br>Dessiné Par  | BoxCad: BoxCad            | Date 15-Oct-13  |
| Material<br>Matière  | 16 Ga H.R.P. & O. (1.4mm) |   |
| Color<br>Couleur   | Asa-61 Grey               | Finish<br>Fini Smooth   |
| Description  |                           | Detail Rev.   |
| 1100DFN 15" x 15" x 8" Body  |                           |   |
| Part Number<br>Numéro Pièce  | Rev.                      | 7   |
| <b>1100DF151508NB</b>  | <b>0</b>                  | 7   |

| Qty        | Part Number       | Rev | Description                         |
|------------|-------------------|-----|-------------------------------------|
| 1          | STK-P-02400S      | 0   | Powder Paint (Asa-61 Grey / Smooth) |
| 1          | 1100DF151508NT-P  | 0   | 1100DFN 15" x 15" x 8" Body Part    |
| 1          | 1100DF151508NBT-P | 0   | 1100DFN 15" x 15" x 8" Body Part    |
| 1          | 1100DF151508NB-P  | 0   | 1100DFN 15" x 15" x 8" Body Part    |
| Parts List |                   |     |                                     |

This drawing is confidential and must not be reproduced or used without the consent of EXM

Ce dessin est confidentiel et ne doit pas être reproduit ou utilisé sans le consentement de EXM

TOP

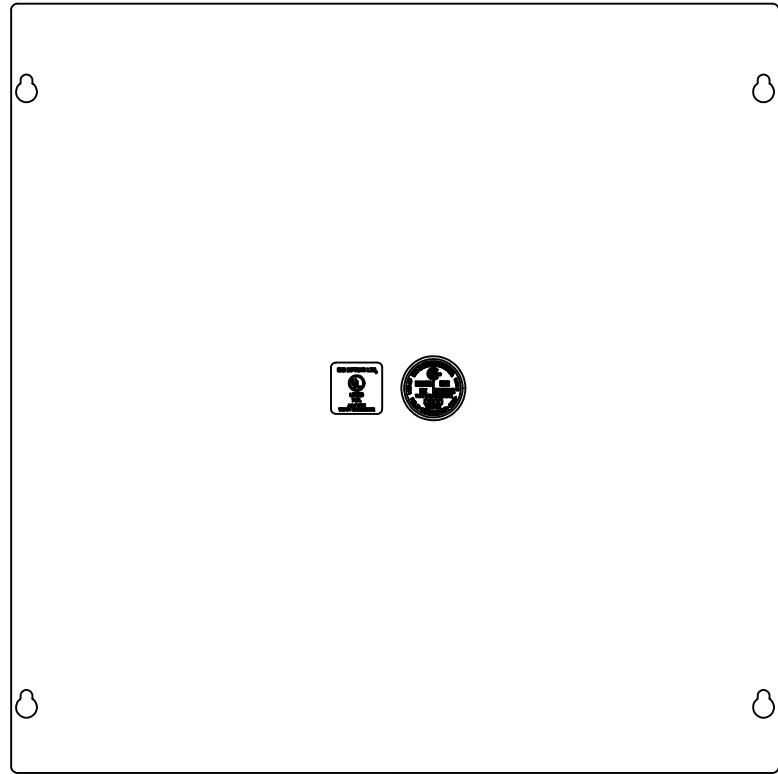

BACK

LEFT

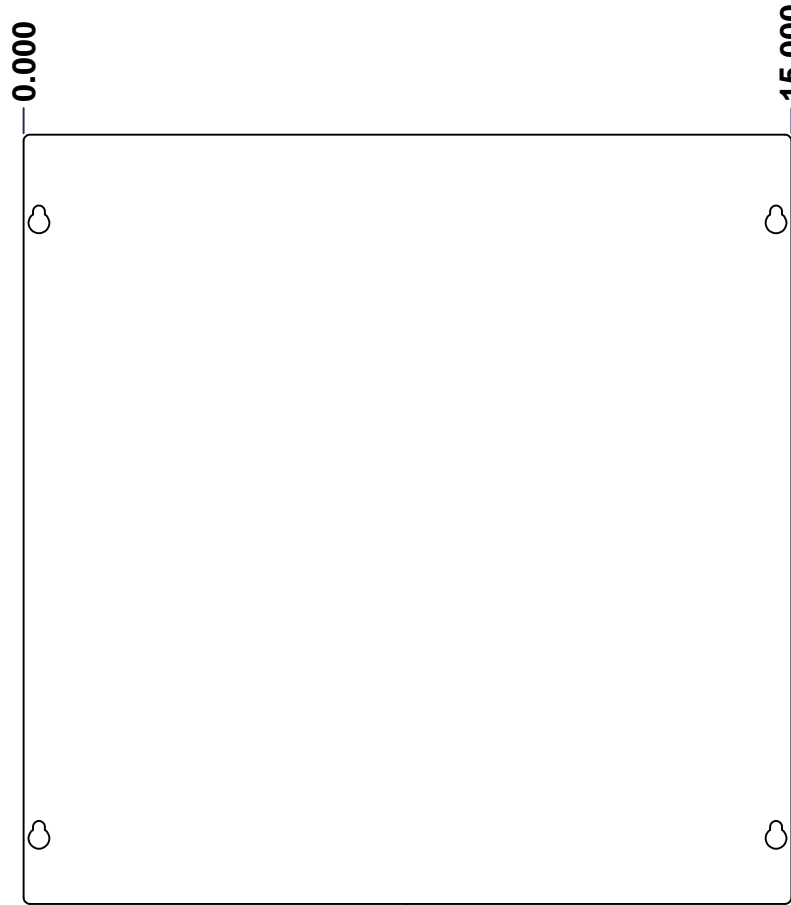

FRONT

RIGHT

| No. | Revisions | Date | By/Par |
|-----|-----------|------|--------|
|     |           |      |        |
|     |           |      |        |
|     |           |      |        |
|     |           |      |        |

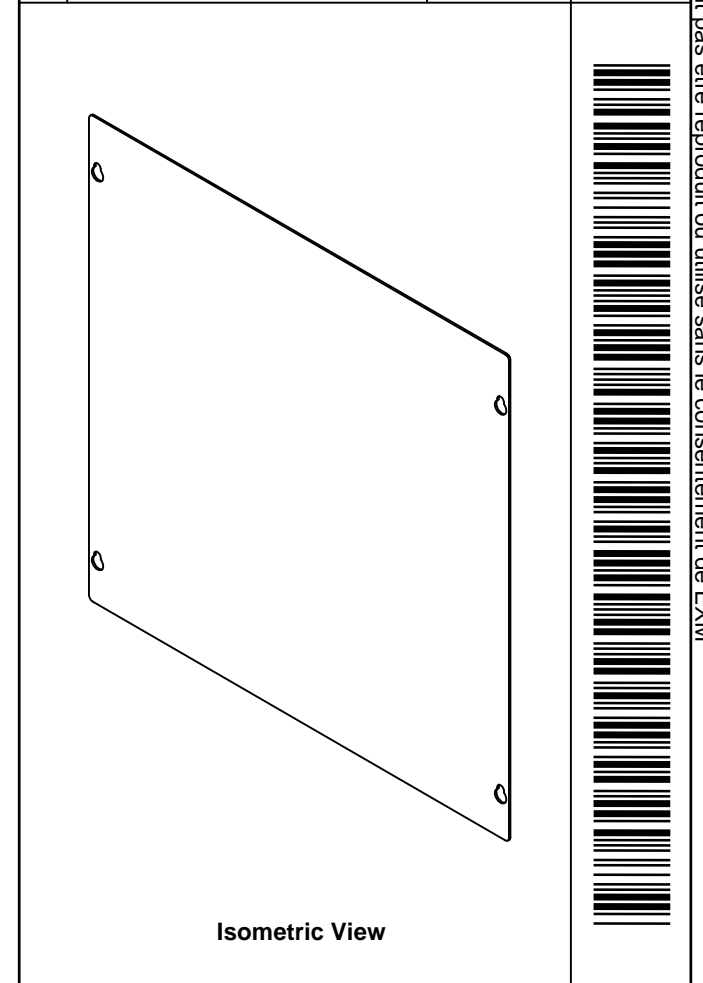

Isometric View

BOTTOM

|  |                       |  |
|--|-----------------------|--|
| Tél: (450) 979-4373<br>Fax: (450) 979-4626<br><a href="http://www.exmweb.com">www.exmweb.com</a> |                       | Flatness<br>Aplatissement<br>Max 3.0mm<br>Projection<br> |
| Customer Client  | Date                  |  |
| Drawn By / Dessiné Par: BoxCad: BoxCad   | Date: 15-Oct-13       |  |
| Material / Matière: 16 Ga H.R.P. & O. (1.4mm)  |                       |  |
| Color / Couleur: Asa-61 Grey   | Finish / Fini: Smooth |  |
| Description: 1100DFN 15" x 15" Cover   |                       | Detail Rev.  |
| Part Number / Numéro Pièce: <b>1100DF151508NC</b>  | Rev. <b>0</b>         | 1 / 3  |

SEE BILL OF MATERIAL ON LAST PAGE

This drawing is confidential and must not be reproduced or used without the consent of EXM

Ce dessin est confidentiel et ne doit pas être reproduit ou utilisé sans le consentement de EXM

| No. | Revisions | Date | By/Par |
|-----|-----------|------|--------|
|     |           |      |        |
|     |           |      |        |
|     |           |      |        |
|     |           |      |        |
|     |           |      |        |

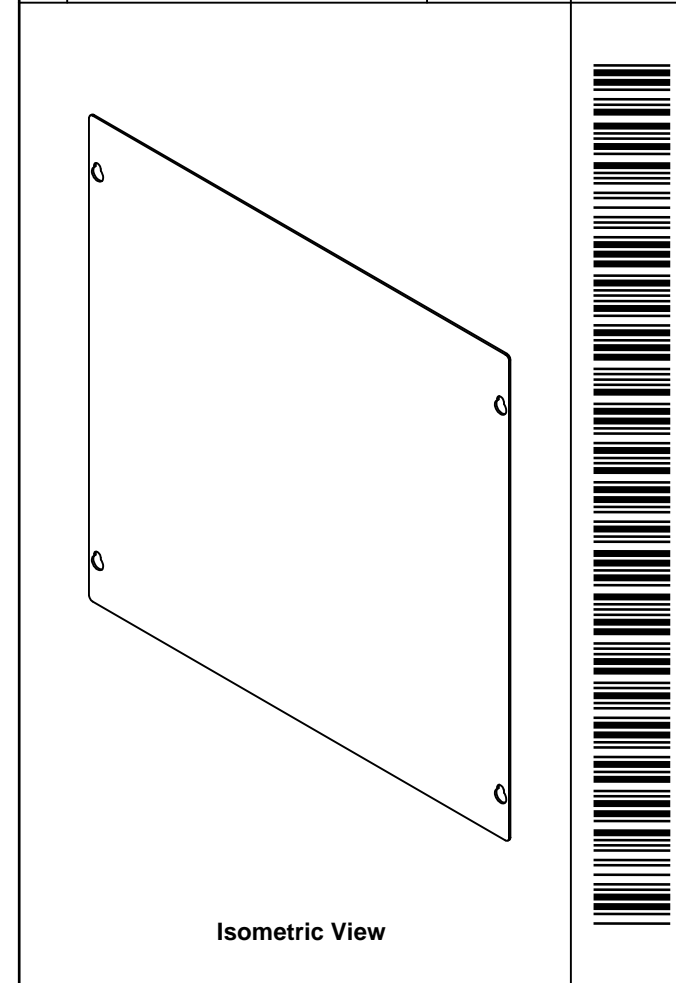

|  |                           |   |
|--|---------------------------|---|
|  Tél: (450) 979-4373<br>Fax: (450) 979-4626<br><a href="http://www.exmweb.com">www.exmweb.com</a> |                           | Flatness<br>Aplatissement<br>Max 3.0mm<br>Projection<br> |
| Customer<br>Client   | Date                      |   |
| Drawn By<br>Dessiné Par  | BoxCad: BoxCad            | Date 15-Oct-13  |
| Material<br>Matière  | 16 Ga H.R.P. & O. (1.4mm) |   |
| Color<br>Couleur   | Asa-61 Grey               | Finish<br>Fini Smooth   |
| Description  |                           | Detail Rev.   |
| 1100DFN 15" x 15" Cover  |                           |   |
| Part Number<br>Numéro Pièce  | Rev.                      | 3   |
| <b>1100DF151508NC</b>  | <b>0</b>                  | <b>3</b>  |

| Qty        | Part Number      | Rev | Description                         |
|------------|------------------|-----|-------------------------------------|
| 1          | STK-S-00950      | 1   | UL 74SL Pull-Box Sticker            |
| 1          | STK-S-00800      | 2   | CSA Electrical Box Sticker          |
| 1          | 1100DF151508NC-P | 0   | 1100DFN 15" x 15" Cover Part        |
| 1          | STK-P-02400S     | 0   | Powder Paint (Asa-61 Grey / Smooth) |
| Parts List |                  |     |                                     |