

This drawing is confidential and must not be reproduced or used without the consent of EXM

Ce dessin est confidentiel et ne doit pas être reproduit ou utilisé sans le consentement de EXM

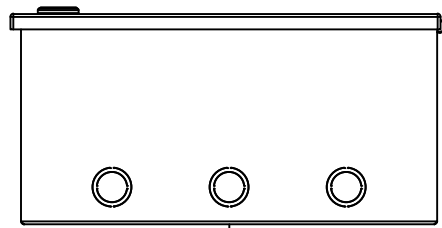

TOP

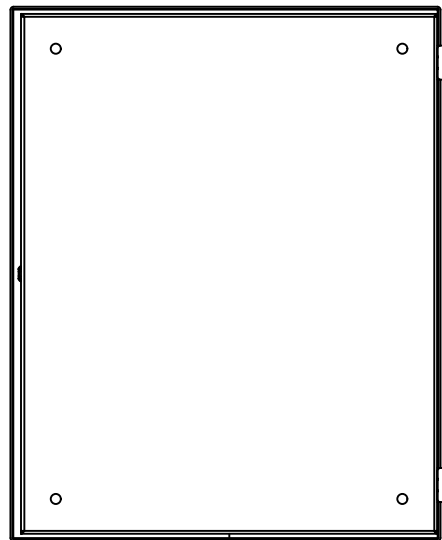

BACK

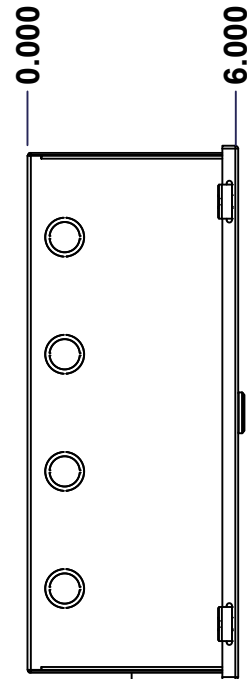

LEFT

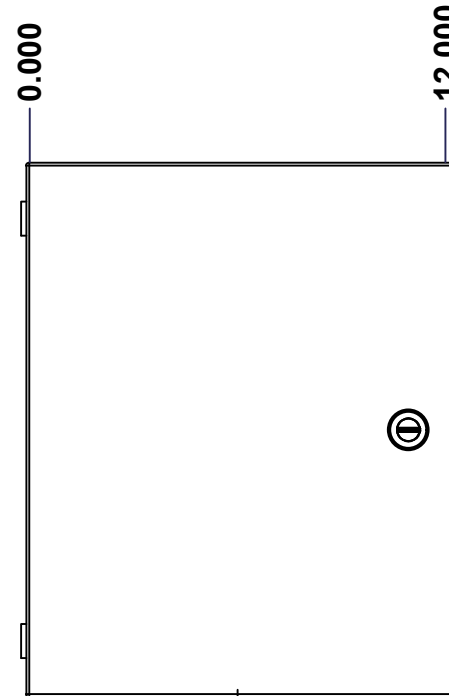

FRONT

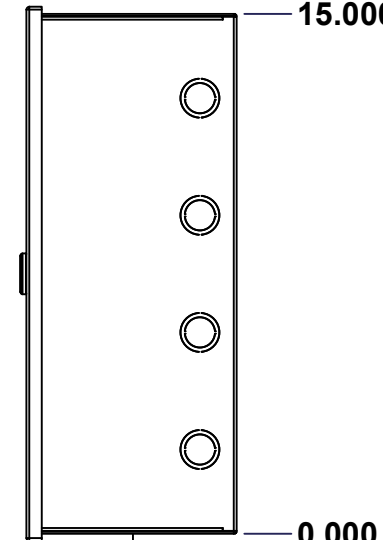

RIGHT

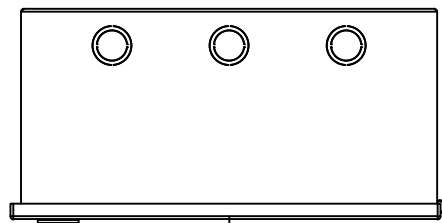

BOTTOM

| No. | Revisions | Date | By/Par |
|-----|-----------|------|--------|
| | | | |
| | | | |
| | | | |
| | | | |
| | | | |

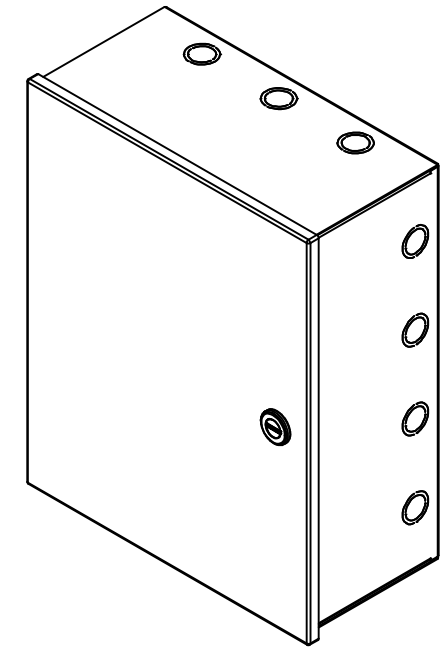

Isometric View

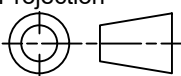

| | | |
|--|---|---|
|  Tél: (450) 979-4373 Fax: (450) 979-4626 www.exmweb.com | | Flatness Aplatissement Max 3.0mm Projection  |
| Customer Client | Date | |
| Drawn By Dessiné Par | BoxCad: BoxCad | Date 1/21/2014 |
| Material Matière | 16 Ga Cold Rolled A1008 CS Type B (1.4mm) | |
| Color Couleur | Asa-61 Grey | Finish Fini Smooth |
| Description 1100E 15" x 12" x 6" Assembly | | Detail Rev. |
| Part Number Numéro Pièce | 1100E151206 | Rev. 0 |

SEE BILL OF MATERIAL ON LAST PAGE

This drawing is confidential and must not be reproduced or used without the consent of EXM

Ce dessin est confidentiel et ne doit pas être reproduit ou utilisé sans le consentement de EXM

| NOTE | |
|------|--|
| ITEM | DESCRIPTION |
| 1 | NEMA 1 Enclosure (IP20) |
| 2 | C/W Standard ground provision on box and cover |
| 3 | W/O Standard door stiffener |
| 4 | W/O Inner panel |
| 5 | W/O Inner panel mounting provision |

| No. | Revisions | Date | By/Par |
|-----|-----------|------|--------|
| | | | |
| | | | |
| | | | |
| | | | |
| | | | |
| | | | |

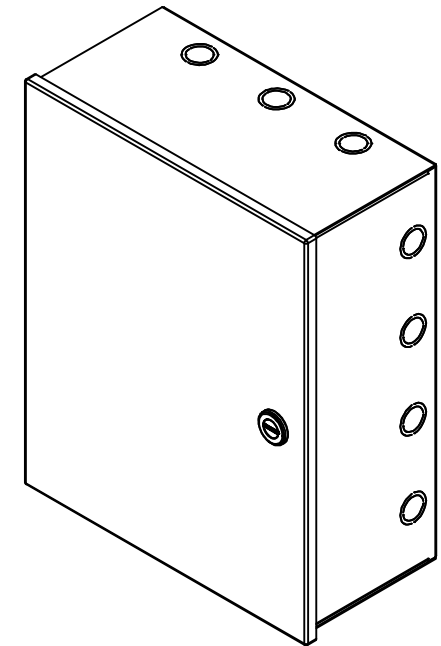

Isometric View



Tél: (450) 979-4373
 Fax: (450) 979-4626
www.exmweb.com

Flatness
Aplatissement
Max 3.0mm
Projection

| | |
|---|-----------------|
| Customer Client | Date |
| Drawn By / Dessiné Par: BoxCad: BoxCad | Date: 1/21/2014 |
| Material / Matière: 16 Ga Cold Rolled A1008 CS Type B (1.4mm) | |

| | |
|------------------------------|-----------------------|
| Color / Couleur: Asa-61 Grey | Finish / Fini: Smooth |
|------------------------------|-----------------------|

| | |
|--|-------------|
| Description: 1100E 15" x 12" x 6" Assembly | Detail Rev. |
|--|-------------|

| | | |
|--|--------|----|
| Part Number / Numéro Pièce: 1100E151206 | Rev. 0 | 2 |
| | | 12 |

| PACKING | | |
|----------------------|-----|---|
| ITEM | QTY | DESCRIPTION |
| Thermal plastic film | 1 | Use with Packing Tunnel Wrapper Machine |
| Packaging label | 1 | White label with product number |

| Qty | Part Number | Rev | Description |
|------------|--------------|-----|---------------------------|
| 1 | 1100E151206C | 0 | 1100E 15" x 12" Cover |
| 1 | 1100E151206B | 0 | 1100E 15" x 12" x 6" Body |
| Parts List | | | |

This drawing is confidential and must not be reproduced or used without the consent of EXM

Ce dessin est confidentiel et ne doit pas être reproduit ou utilisé sans le consentement de EXM

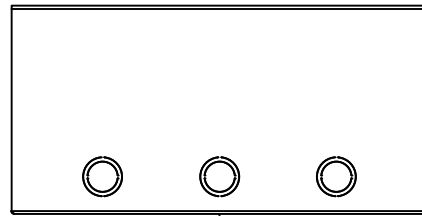

TOP



BACK

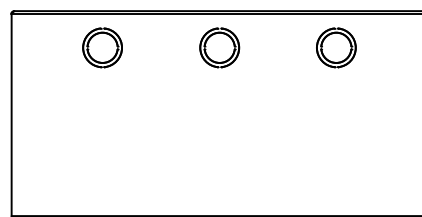

BOTTOM

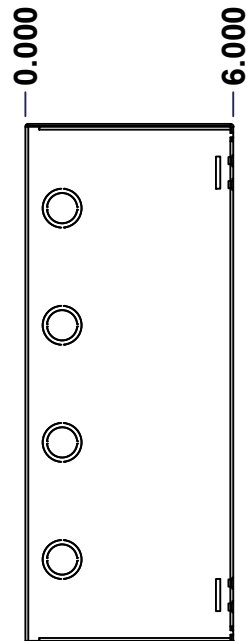

LEFT

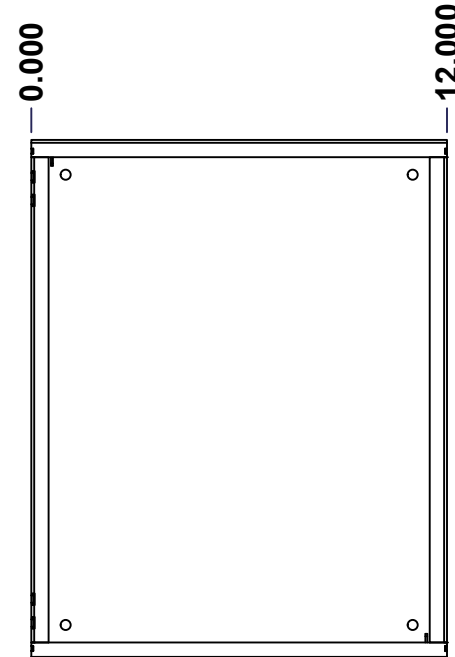

FRONT

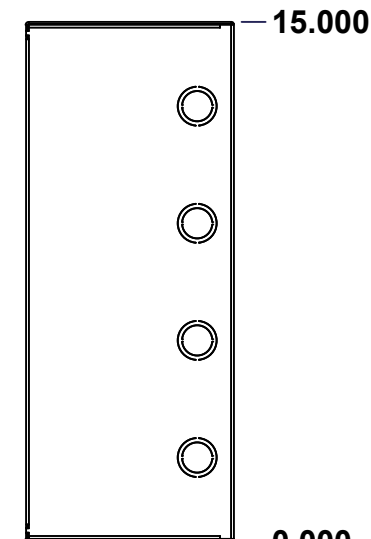

RIGHT

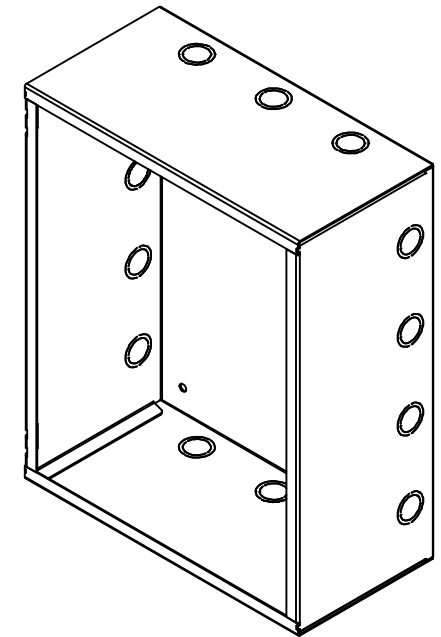

Isometric View

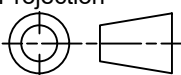

| No. | Revisions | Date | By/Par |
|-----|-----------|------|--------|
| | | | |
| | | | |
| | | | |
| | | | |
| | | | |

| | | |
|--|---|---|
|  Tél: (450) 979-4373 Fax: (450) 979-4626 www.exmweb.com | | Flatness Aplatissement Max 3.0mm Projection  |
| Customer Client | Date | |
| Drawn By Dessiné Par | BoxCad: BoxCad | Date 1/21/2014 |
| Material Matière | 16 Ga Cold Rolled A1008 CS Type B (1.4mm) | |
| Color Couleur | Asa-61 Grey | Finish Fini Smooth |
| Description 1100E 15" x 12" x 6" Body | | Detail Rev. |
| Part Number Numéro Pièce | 1100E151206B | Rev. 3 0 |

SEE BILL OF MATERIAL ON LAST PAGE

This drawing is confidential and must not be reproduced or used without the consent of EXM

Ce dessin est confidentiel et ne doit pas être reproduit ou utilisé sans le consentement de EXM

STANDARD FEATURES ARE NOT LISTED IN THIS HOLE TABLE

HOLE TABLE - TOP VIEW (CUSTOM FEATURE ONLY)

| CUT-OUT | XDIM | YDIM | DESCRIPTION |
|---------|-------|-------|--------------------|
| 1 | 9.375 | 1.063 | DKO Ø1.125 - 0.875 |
| 2 | 6.000 | 1.063 | DKO Ø1.125 - 0.875 |
| 3 | 2.625 | 1.063 | DKO Ø1.125 - 0.875 |

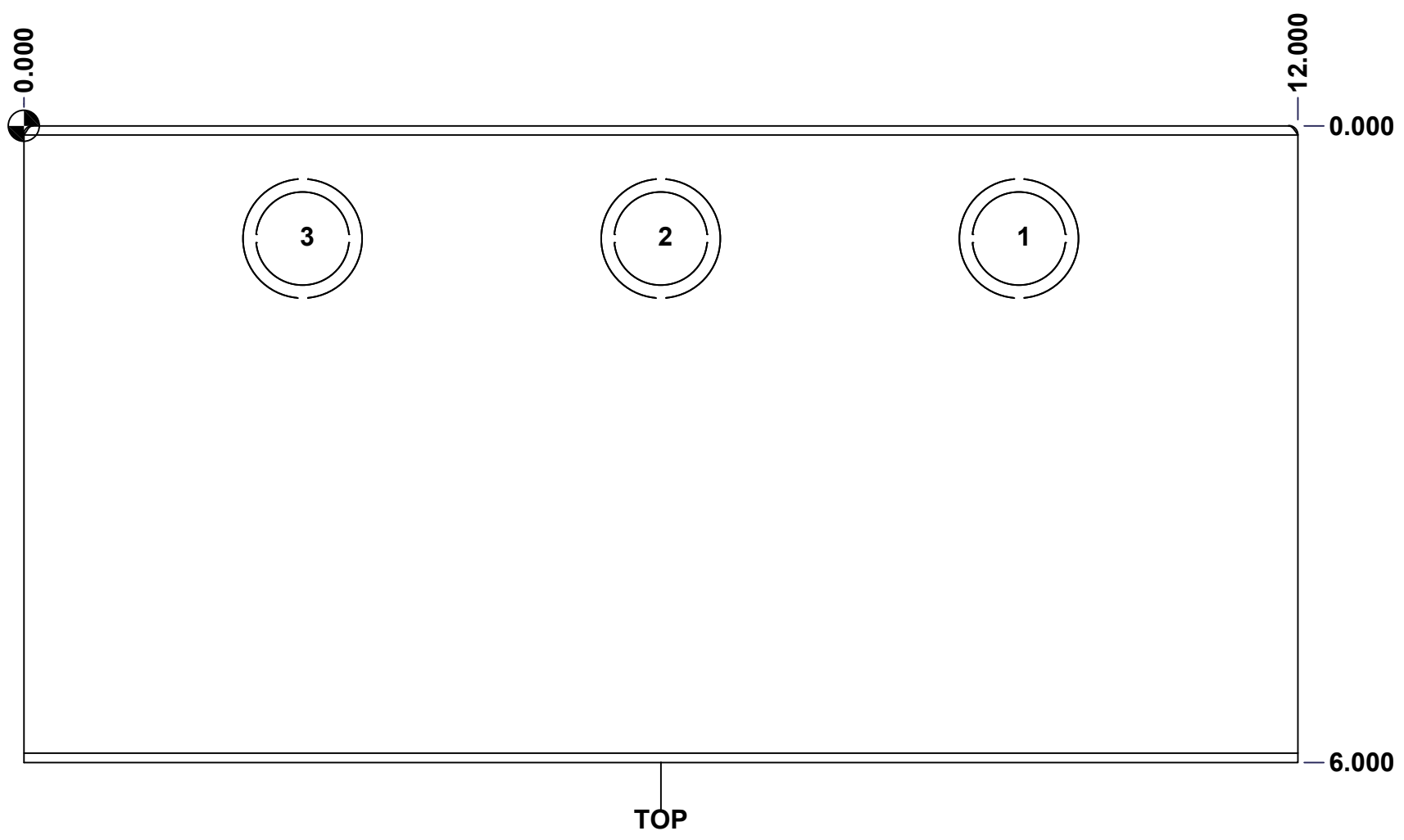

| | | | |
|--|-----------------------------|----------|----|
| | Description | Status | |
| | 1100E 15" x 12" x 6" Body | (NULL) | |
| | Part Number Numéro Pièce | Rev. | 4 |
| | 1100E151206B | 0 | 12 |

This drawing is confidential and must not be reproduced or used without the consent of EXM

Ce dessin est confidentiel et ne doit pas être reproduit ou utilisé sans le consentement de EXM

STANDARD FEATURES ARE NOT LISTED IN THIS HOLE TABLE

HOLE TABLE - RIGHT VIEW (CUSTOM FEATURE ONLY)

| CUT-OUT | XDIM | YDIM | DESCRIPTION |
|---------|-------|--------|--------------------|
| 1 | 1.063 | 2.438 | DKO Ø1.125 - 0.875 |
| 2 | 1.063 | 5.812 | DKO Ø1.125 - 0.875 |
| 3 | 1.063 | 9.188 | DKO Ø1.125 - 0.875 |
| 4 | 1.063 | 12.562 | DKO Ø1.125 - 0.875 |

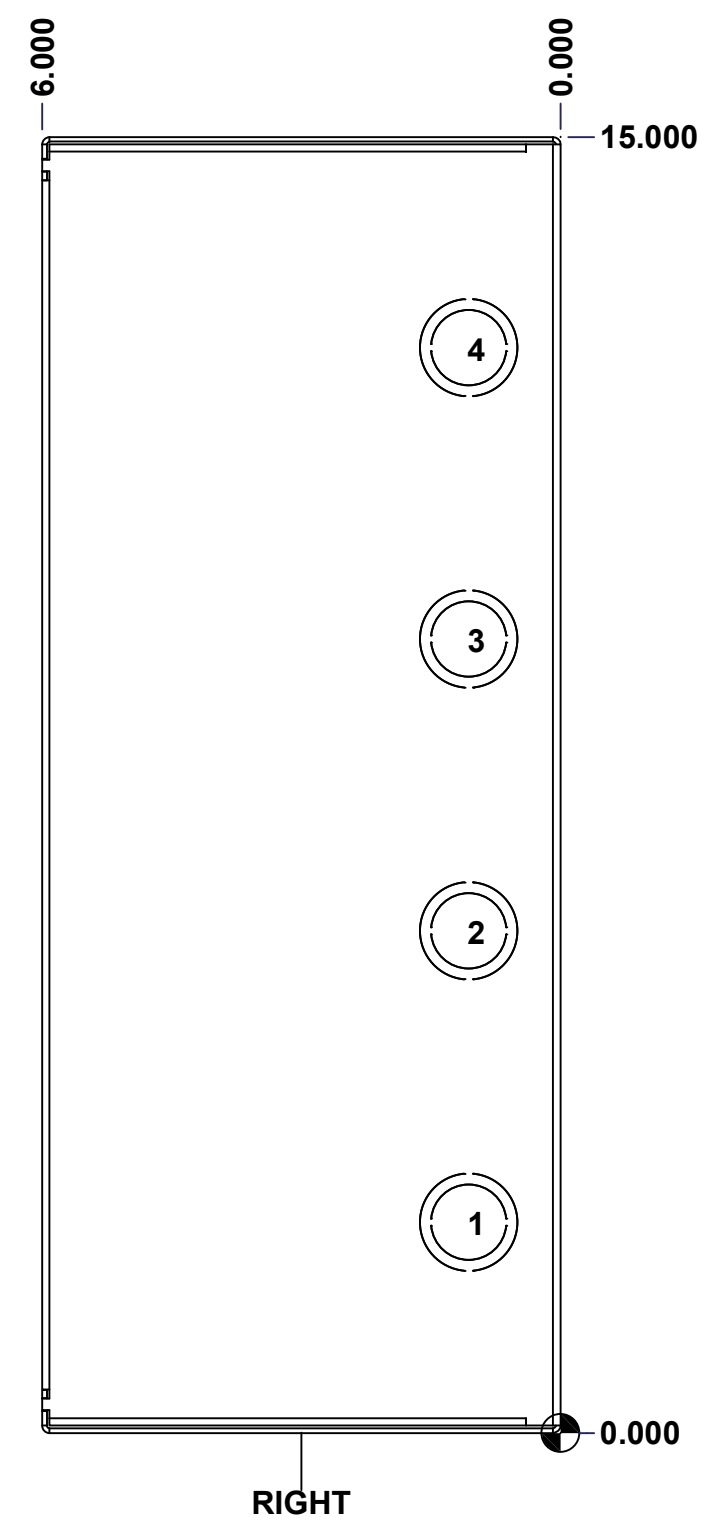

| | | | |
|--|-----------------------------|----------|----|
| | Description | Status | |
| | 1100E 15" x 12" x 6" Body | (NULL) | |
| | Part Number Numéro Pièce | Rev. | 5 |
| | 1100E151206B | 0 | 12 |

This drawing is confidential and must not be reproduced or used without the consent of EXM

Ce dessin est confidentiel et ne doit pas être reproduit ou utilisé sans le consentement de EXM

STANDARD FEATURES ARE NOT LISTED IN THIS HOLE TABLE

HOLE TABLE - BOTTOM VIEW (CUSTOM FEATURE ONLY)

| CUT-OUT | XDIM | YDIM | DESCRIPTION |
|---------|-------|-------|--------------------|
| 1 | 9.375 | 1.063 | DKO Ø1.125 - 0.875 |
| 2 | 6.000 | 1.063 | DKO Ø1.125 - 0.875 |
| 3 | 2.625 | 1.063 | DKO Ø1.125 - 0.875 |

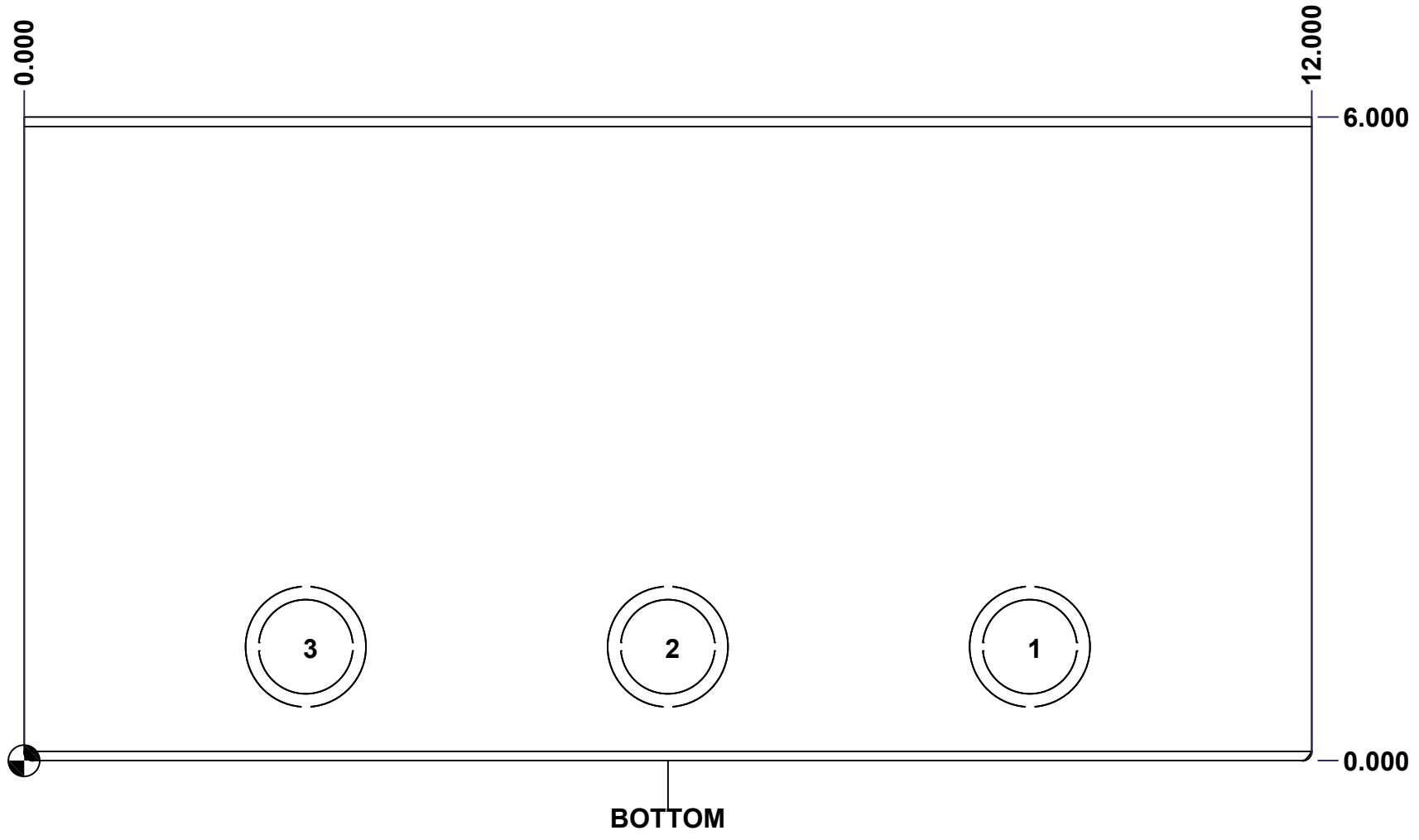

| | | | |
|--|-----------------------------|----------|----|
| | Description | Status | |
| | 1100E 15" x 12" x 6" Body | (NULL) | |
| | Part Number Numéro Pièce | Rev. | 6 |
| | 1100E151206B | 0 | 12 |

This drawing is confidential and must not be reproduced or used without the consent of EXM

Ce dessin est confidentiel et ne doit pas être reproduit ou utilisé sans le consentement de EXM

STANDARD FEATURES ARE NOT LISTED IN THIS HOLE TABLE

HOLE TABLE - LEFT VIEW (CUSTOM FEATURE ONLY)

| CUT-OUT | XDIM | YDIM | DESCRIPTION |
|---------|-------|--------|--------------------|
| 1 | 1.063 | 2.438 | DKO Ø1.125 - 0.875 |
| 2 | 1.063 | 5.812 | DKO Ø1.125 - 0.875 |
| 3 | 1.063 | 9.188 | DKO Ø1.125 - 0.875 |
| 4 | 1.063 | 12.562 | DKO Ø1.125 - 0.875 |

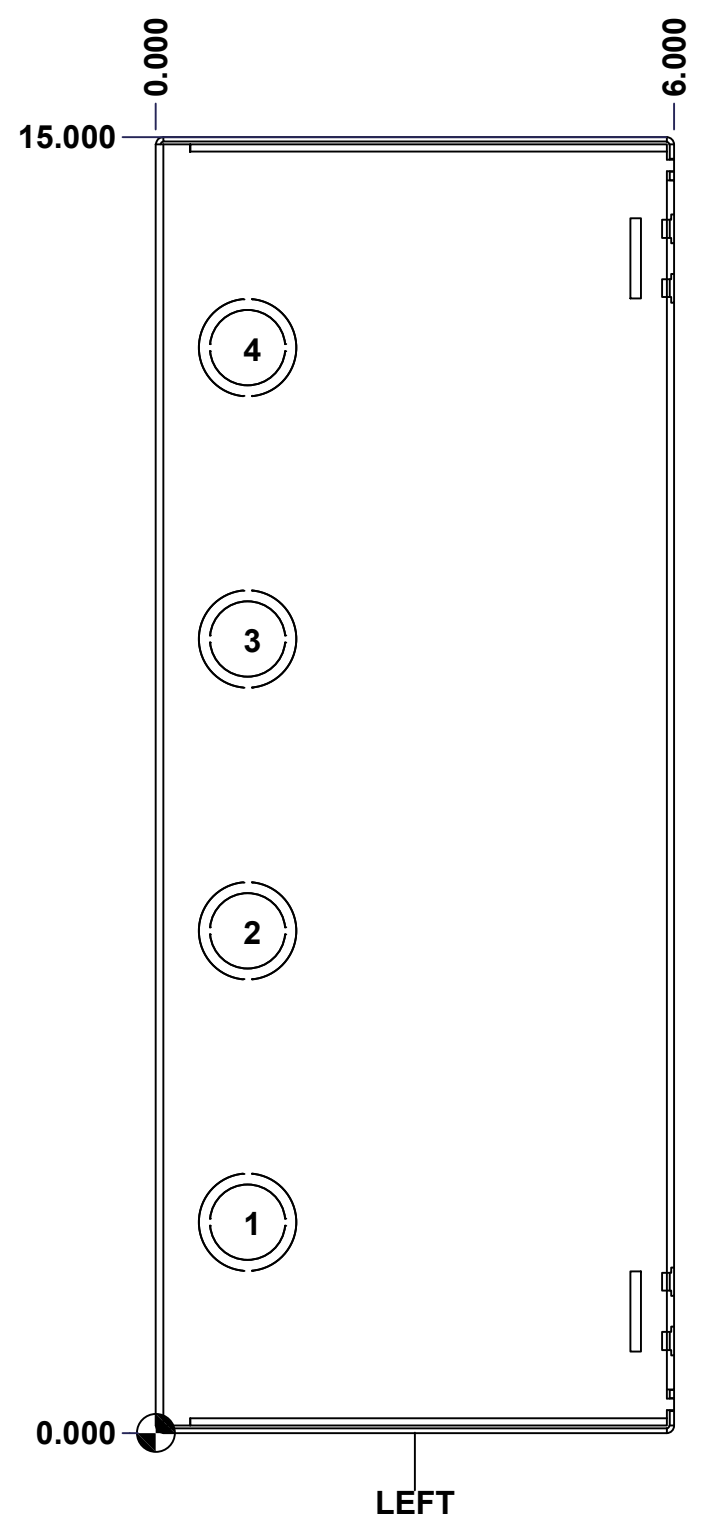

| | | | |
|--|-----------------------------|----------|----|
| | Description | Status | |
| | 1100E 15" x 12" x 6" Body | (NULL) | |
| | Part Number Numéro Pièce | Rev. | 7 |
| | 1100E151206B | 0 | 12 |

This drawing is confidential and must not be reproduced or used without the consent of EXM

Ce dessin est confidentiel et ne doit pas être reproduit ou utilisé sans le consentement de EXM

| STANDARD FEATURES ARE NOT LISTED IN THIS HOLE TABLE | | | |
|---|--------|--------|-------------|
| HOLE TABLE - BACK VIEW (CUSTOM FEATURE ONLY) | | | |
| CUT-OUT | XDIM | YDIM | DESCRIPTION |
| 1 | 11.000 | 1.000 | RND Ø0.290 |
| 2 | 11.000 | 14.000 | RND Ø0.290 |
| 3 | 1.000 | 14.000 | RND Ø0.290 |
| 4 | 1.000 | 1.000 | RND Ø0.290 |

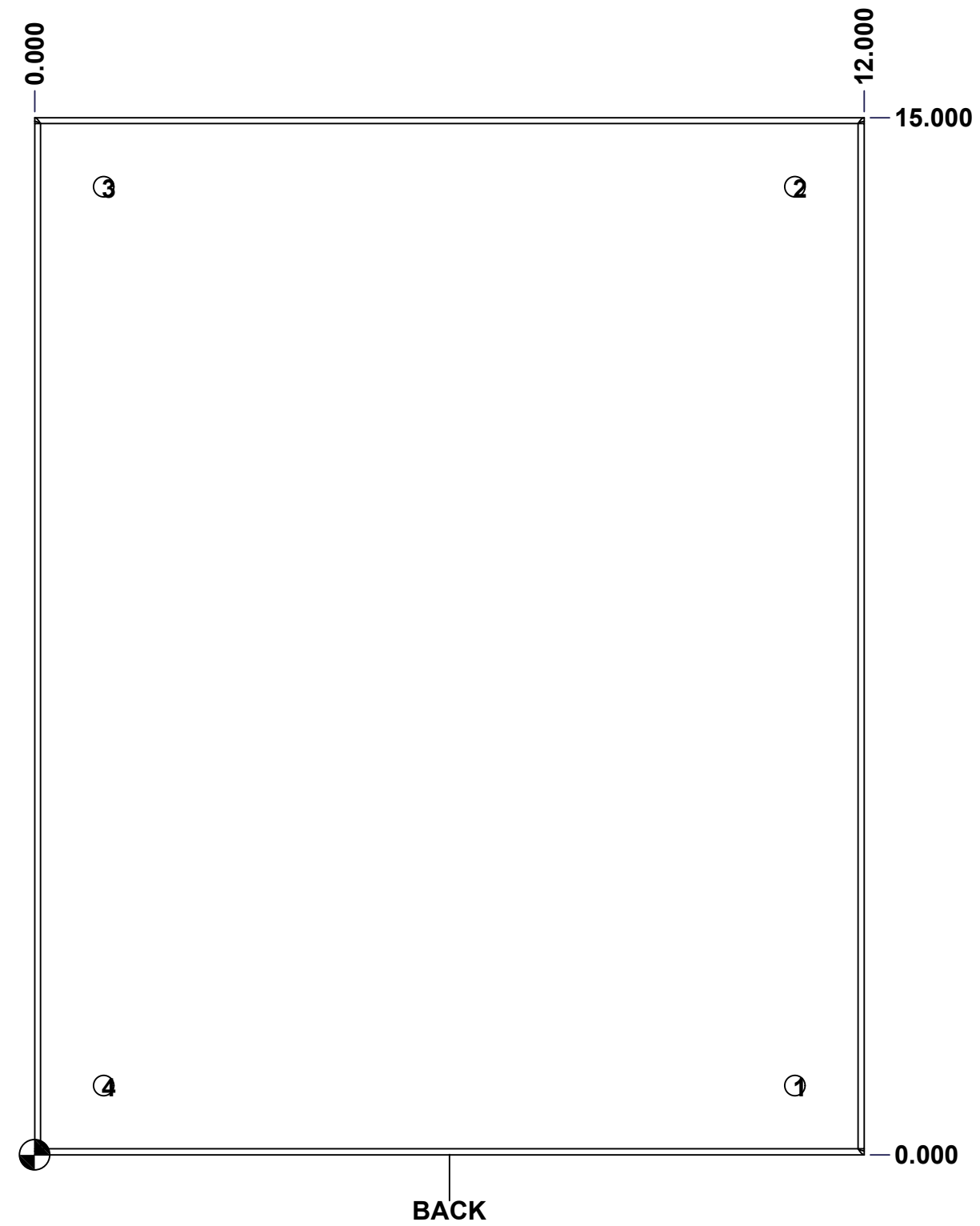

| | | | |
|--|-----------------------------|----------|----|
| | Description | Status | |
| | 1100E 15" x 12" x 6" Body | (NULL) | |
| | Part Number Numéro Pièce | Rev. | |
| | 1100E151206B | 0 | 8 |
| | | | 12 |

This drawing is confidential and must not be reproduced or used without the consent of EXM

Ce dessin est confidentiel et ne doit pas être reproduit ou utilisé sans le consentement de EXM

| No. | Revisions | Date | By/Par |
|-----|-----------|------|--------|
| | | | |
| | | | |
| | | | |
| | | | |
| | | | |

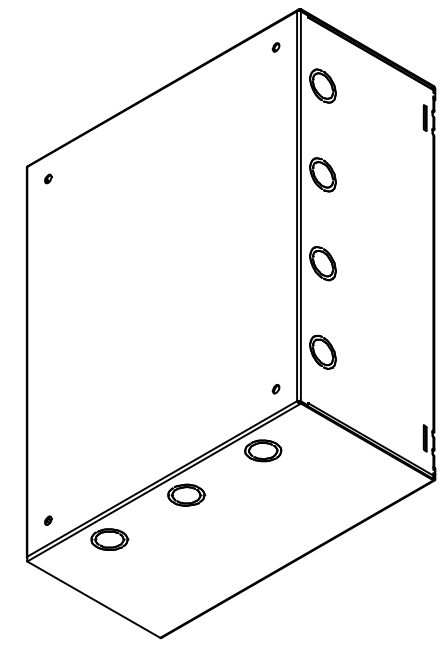

Isometric View

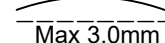
| | | |
|--|-----------------------|---|
|  Tél: (450) 979-4373 Fax: (450) 979-4626 www.exmweb.com | | Flatness Aplatissement  Max 3.0mm |
| Customer Client | | Date |
| Drawn By / Dessiné Par: BoxCad: BoxCad | | Date: 1/21/2014 |
| Material / Matière: 16 Ga Cold Rolled A1008 CS Type B (1.4mm) | | |
| Color / Couleur: Asa-61 Grey | Finish / Fini: Smooth | |
| Description: 1100E 15" x 12" x 6" Body | | Detail Rev. |
| Part Number / Numéro Pièce: 1100E151206B | | Rev. 9 0 |

| Qty | Part Number | Rev | Description |
|------------|----------------|-----|-------------------------------------|
| 1 | STK-P-02400S | 0 | Powder Paint (Asa-61 Grey / Smooth) |
| 1 | 1100E151206B-P | 0 | 1100E 15" x 12" x 6" Body Part |
| Parts List | | | |

This drawing is confidential and must not be reproduced or used without the consent of EXM

Ce dessin est confidentiel et ne doit pas être reproduit ou utilisé sans le consentement de EXM

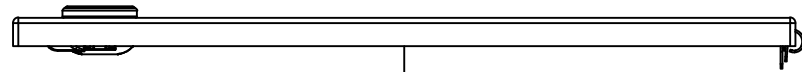

TOP

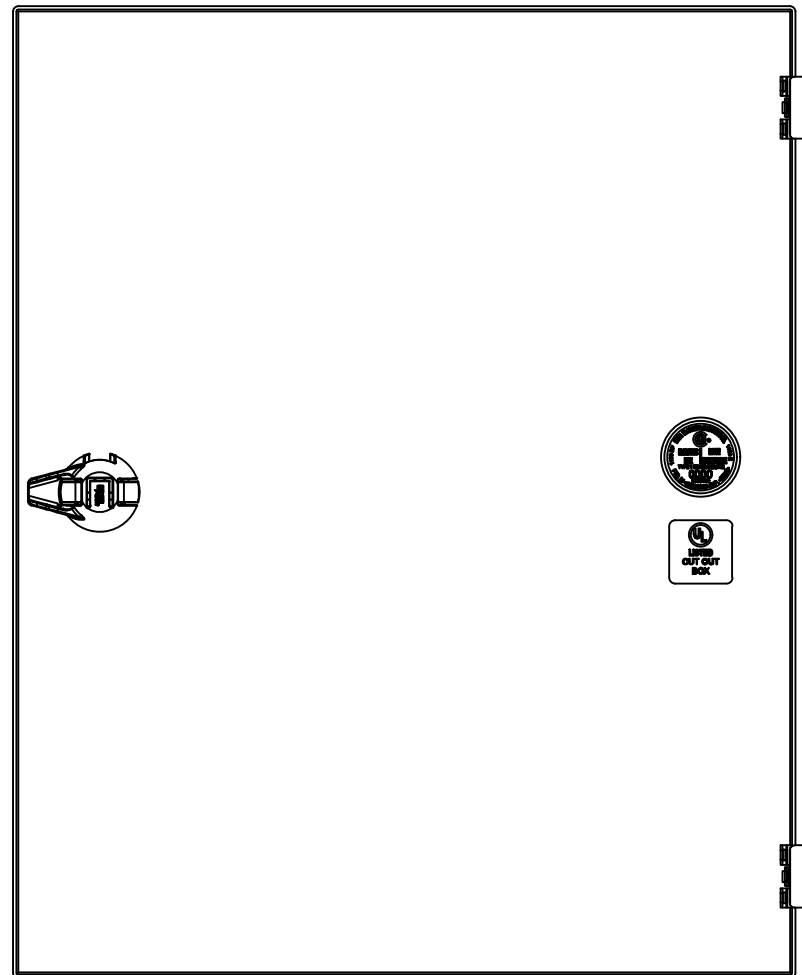

BACK

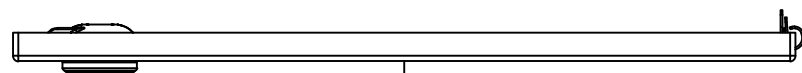

BOTTOM

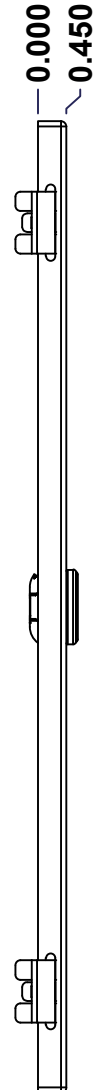

LEFT

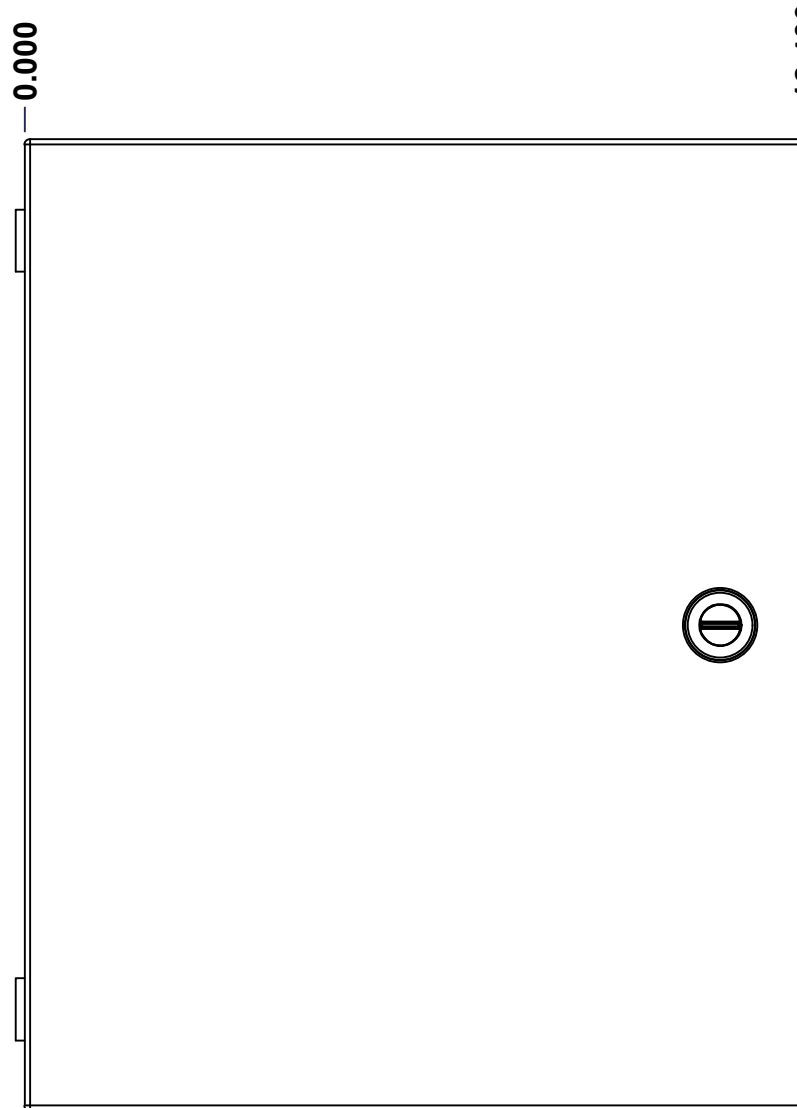

FRONT

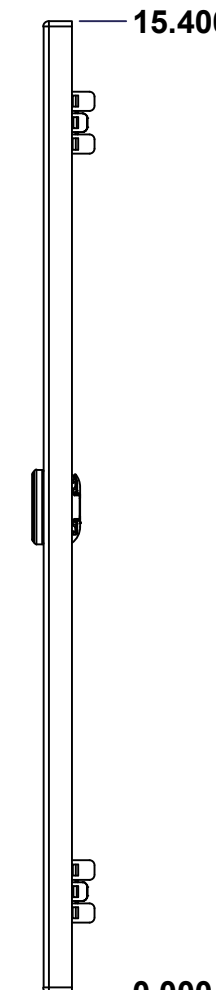

RIGHT

| No. | Revisions | Date | By/Par |
|-----|-----------|------|--------|
| | | | |
| | | | |
| | | | |
| | | | |
| | | | |

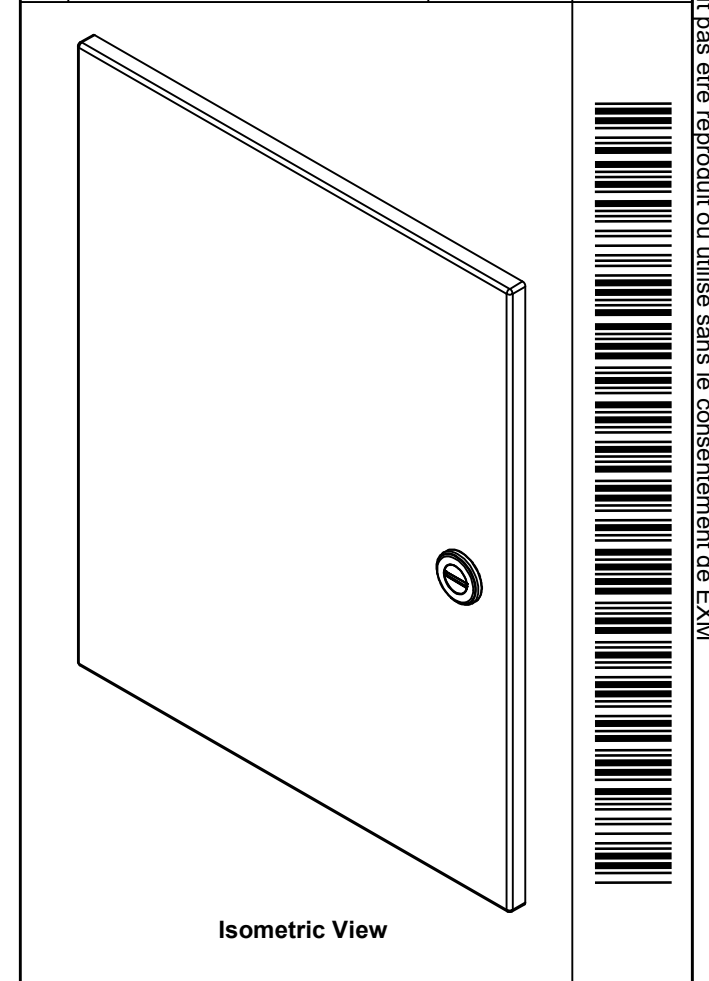

Isometric View

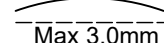
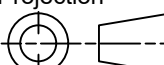
| | | |
|--|---|--|
|  Tél: (450) 979-4373 Fax: (450) 979-4626 www.exmweb.com | | Flatness Aplatissement  Max 3.0mm Projection  |
| Customer Client | Date | |
| Drawn By Dessiné Par | BoxCad: BoxCad | Date 1/21/2014 |
| Material Matière | 16 Ga Cold Rolled A1008 CS Type B (1.4mm) | |
| Color Couleur | Asa-61 Grey | Finish Fini Smooth |
| Description | Detail Rev. | |
| 1100E 15" x 12" Cover | | |
| Part Number Numéro Pièce | Rev. | 10 |
| 1100E151206C | 0 | 12 |

SEE BILL OF MATERIAL ON LAST PAGE

This drawing is confidential and must not be reproduced or used without the consent of EXM

Ce dessin est confidentiel et ne doit pas être reproduit ou utilisé sans le consentement de EXM

STANDARD FEATURES ARE NOT LISTED IN THIS HOLE TABLE

HOLE TABLE - FRONT VIEW (CUSTOM FEATURE ONLY)

| CUT-OUT | XDIM | YDIM | DESCRIPTION |
|---------|--------|-------|-------------------------|
| 1 | 11.025 | 7.700 | LOCK 880 SCQ1-SL @ 0.0° |

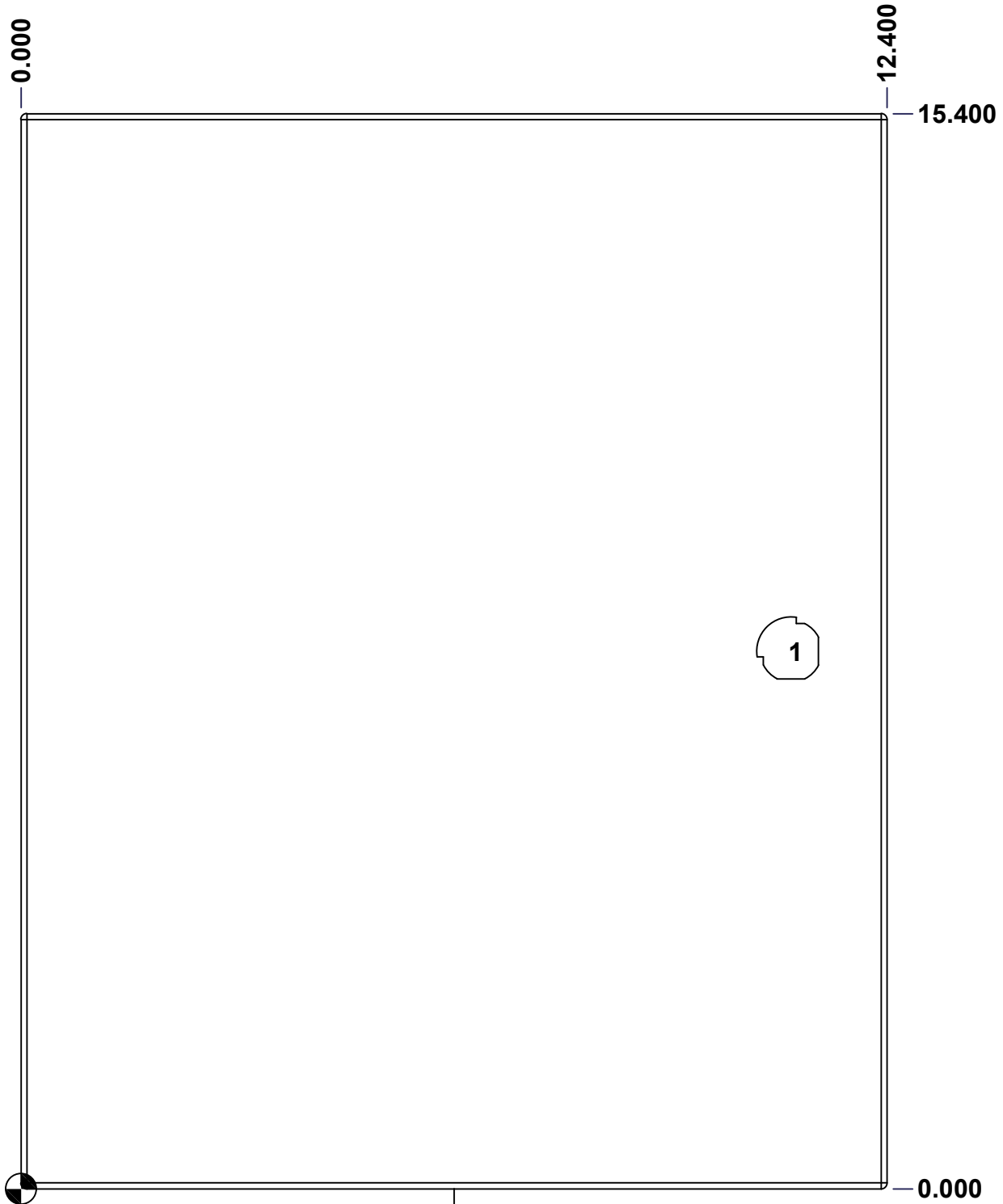

FRONT

| | | | |
|--|-----------------------------|----------|----|
| | Description | Status | |
| | 1100E 15" x 12" Cover | (NULL) | |
| | Part Number Numéro Pièce | Rev. | 11 |
| | 1100E151206C | 0 | 12 |

This drawing is confidential and must not be reproduced or used without the consent of EXM

Ce dessin est confidentiel et ne doit pas être reproduit ou utilisé sans le consentement de EXM

| No. | Revisions | Date | By/Par |
|-----|-----------|------|--------|
| | | | |
| | | | |
| | | | |
| | | | |
| | | | |

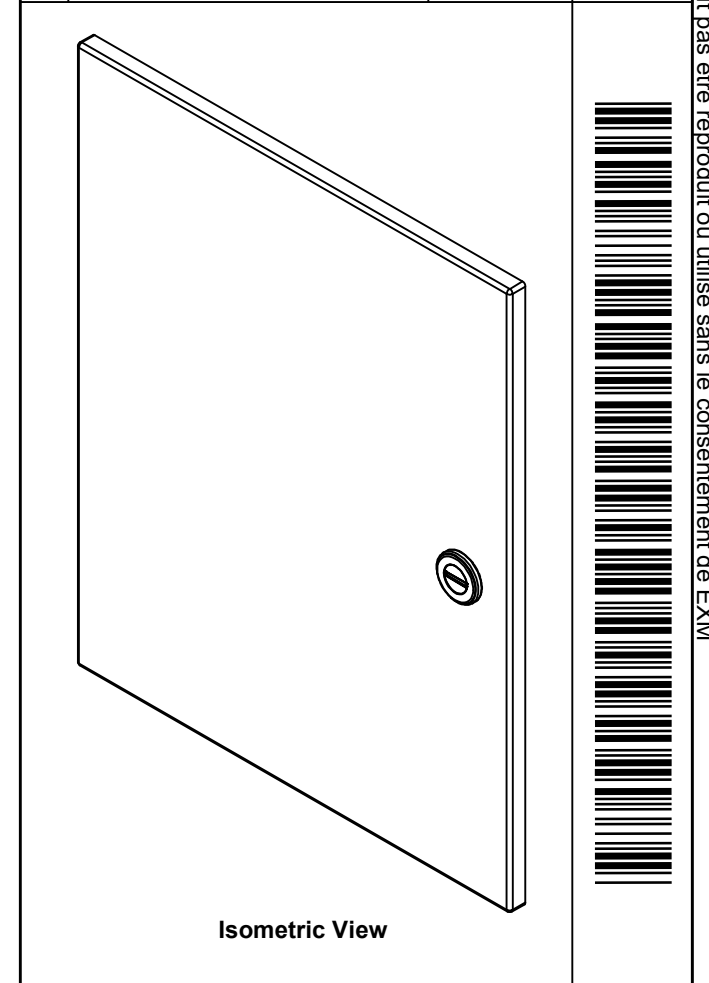

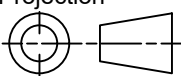
| | | |
|--|---|---|
|  Tél: (450) 979-4373 Fax: (450) 979-4626 www.exmweb.com | | Flatness Aplatissement Max 3.0mm Projection  |
| Customer Client | Date | |
| Drawn By Dessiné Par | BoxCad: BoxCad | Date 1/21/2014 |
| Material Matière | 16 Ga Cold Rolled A1008 CS Type B (1.4mm) | |
| Color Couleur | Asa-61 Grey | Finish Fini Smooth |
| Description | | Detail Rev. |
| 1100E 15" x 12" Cover | | |
| Part Number Numéro Pièce | Rev. | 12 |
| 1100E151206C | 0 | 12 |

| 1 | 880 SCQ1-SL | 0 | 1100 1/4 Turn Lock |
|------------|----------------|-----|-------------------------------------|
| 1 | STK-S-00900 | 0 | UL Cut-Out Box Sticker |
| 1 | STK-S-00800 | 2 | CSA Electrical Box Sticker |
| 2 | STK-Q-33361 | 0 | Spring Steel Hinge |
| 1 | STK-P-02400S | 0 | Powder Paint (Asa-61 Grey / Smooth) |
| 1 | 1100E151206C-P | 0 | 1100E 15" x 12" x 6" Cover Part |
| QTY | Part Number | Rev | Description |
| Parts List | | | |