

This drawing is confidential and must not be reproduced or used without the consent of EXM

Ce dessin est confidentiel et ne doit pas être reproduit ou utilisé sans le consentement de EXM

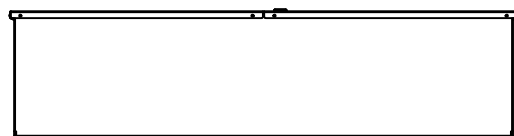

TOP

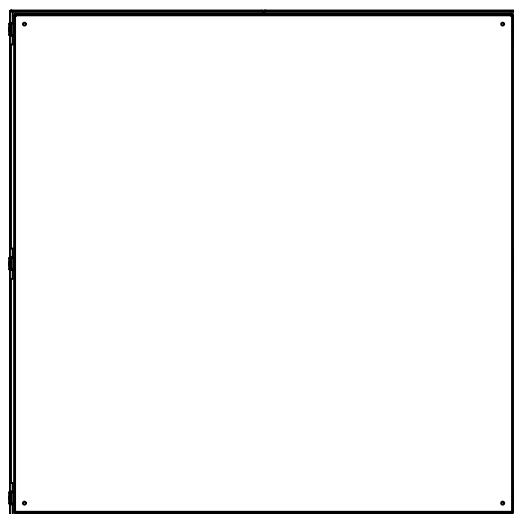

BACK

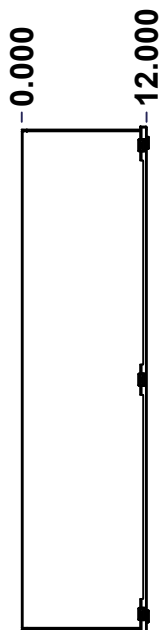

LEFT

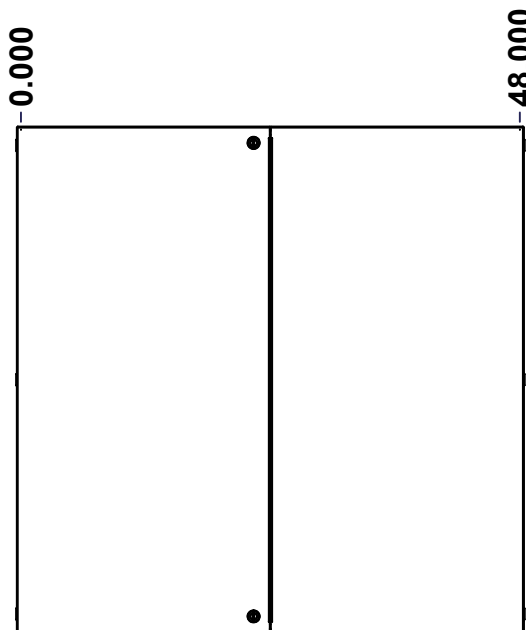

FRONT

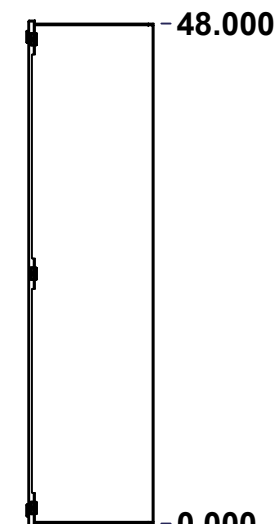

RIGHT

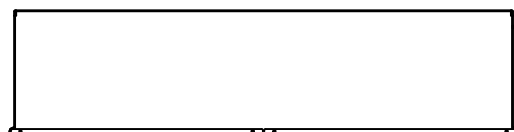

BOTTOM

No.	Revisions	Date	By/Par

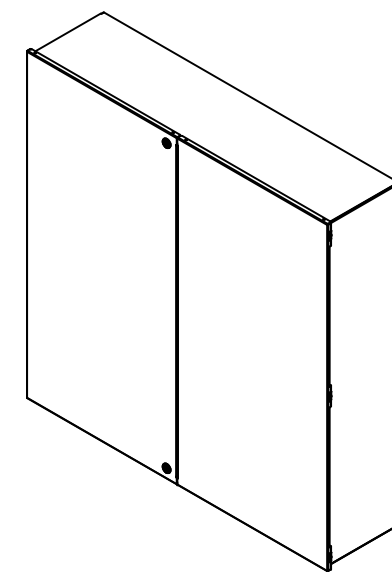

Isometric View

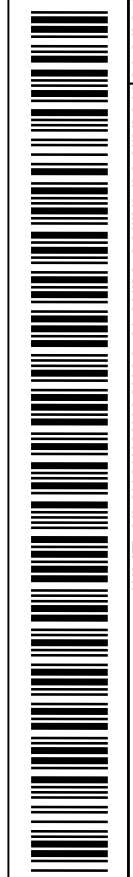

Tél: (450) 979-4373  
 Fax: (450) 979-4626  
[www.exmweb.com](http://www.exmweb.com)

Flatness  
Aplatissement  
Max 3.0mm  
Projection

Customer Client	Date
Drawn By / Dessiné Par: BoxCad: BoxCad	Date: 1/28/2014
Material / Matière: 14 Ga Cold Rolled A1008 CS Type B (1.7mm)	
Color / Couleur: Asa-61 Grey	Finish / Fini: Smooth
Description: 1100EN 48" x 48" x 12" Assembly	Detail Rev.
Part Number / Numéro Pièce: 1100EDD484812N	Rev. 0

SEE BILL OF MATERIAL ON LAST PAGE

1
2

This drawing is confidential and must not be reproduced or used without the consent of EXM

Ce dessin est confidentiel et ne doit pas être reproduit ou utilisé sans le consentement de EXM

NOTE	
ITEM	DESCRIPTION
1	NEMA 1 Enclosure
2	C/W Standard ground provision on box and cover
3	W/O Standard door stiffener
4	W/O Inner panel
5	W/O Inner panel mounting provision

No.	Revisions	Date	By/Par

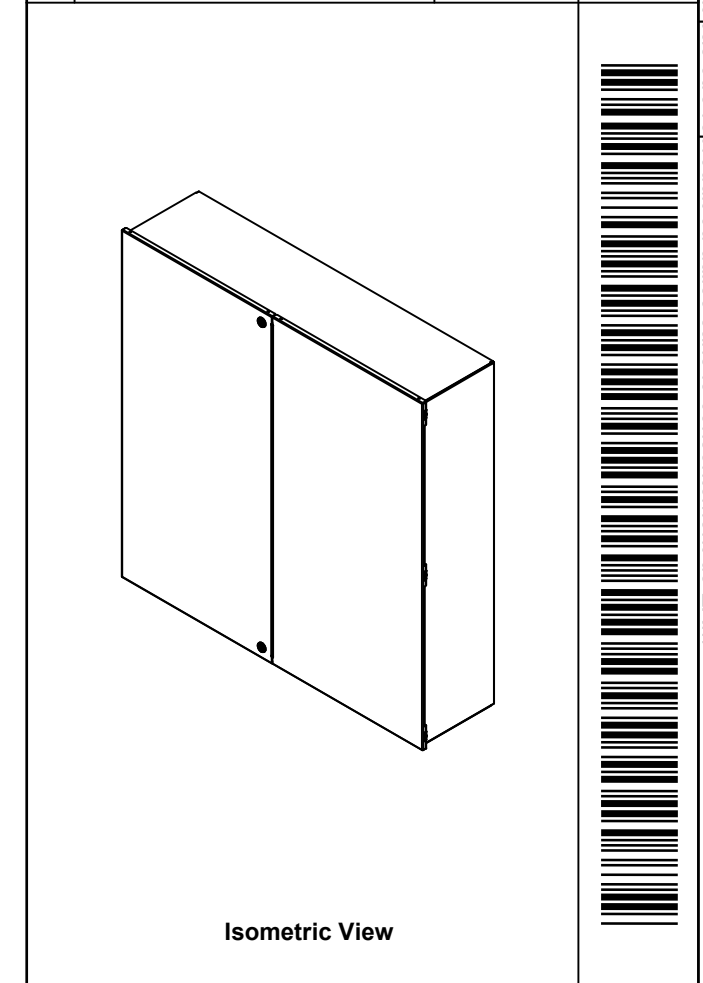

Isometric View

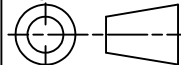
 Tél: (450) 979-4373 Fax: (450) 979-4626 <a href="http://www.exmweb.com">www.exmweb.com</a>		Flatness Aplatissement Max 3.0mm Projection 
Customer Client	Date	
Drawn By Dessiné Par	BoxCad: BoxCad	Date 1/28/2014
Material Matière	14 Ga Cold Rolled A1008 CS Type B (1.7mm)	
Color Couleur	Asa-61 Grey	Finish Fini Smooth
Description	Detail Rev.	
1100EN 48" x 48" x 12" Assembly		
Part Number Numéro Pièce	1100EDD484812N	Rev. 2 0

PACKING		
ITEM	QTY	DESCRIPTION
Cardboard sleeve	2	Top and Bottom
Plastic strap - Black	2	To squeeze the 2 cardboard sleeve together
Thermal plastic film	1	Use with Packing Tunnel Wrapper Machine
Packaging label	1	White label with product number

Qty	Part Number	Rev	Description
1	1100EDD484812NFD	0	1100EN 48" x 48" Flange Cover
1	1100EDD484812NLD	0	1100EN 48" x 48" Lock Cover
1	1100EDD484812NB	0	1100EN 48" x 48" x 12" Body
Parts List			

This drawing is confidential and must not be reproduced or used without the consent of EXM

Ce dessin est confidentiel et ne doit pas être reproduit ou utilisé sans le consentement de EXM

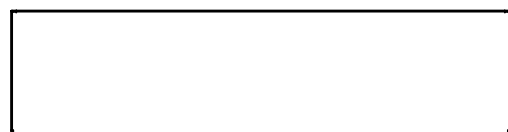

TOP

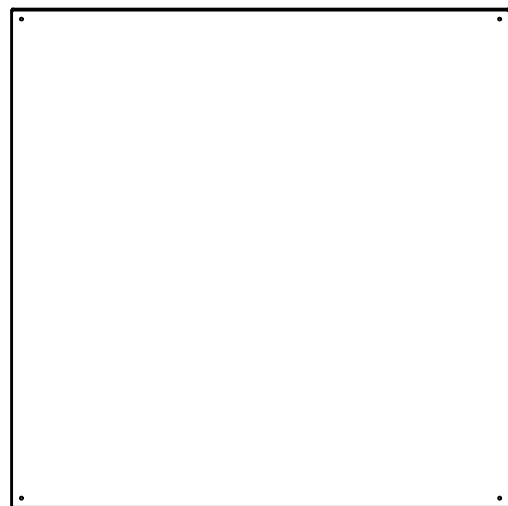

BACK

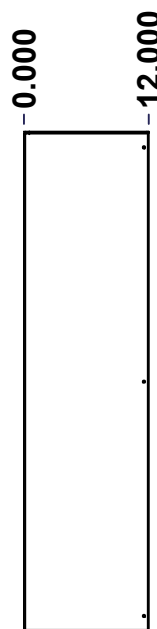

LEFT

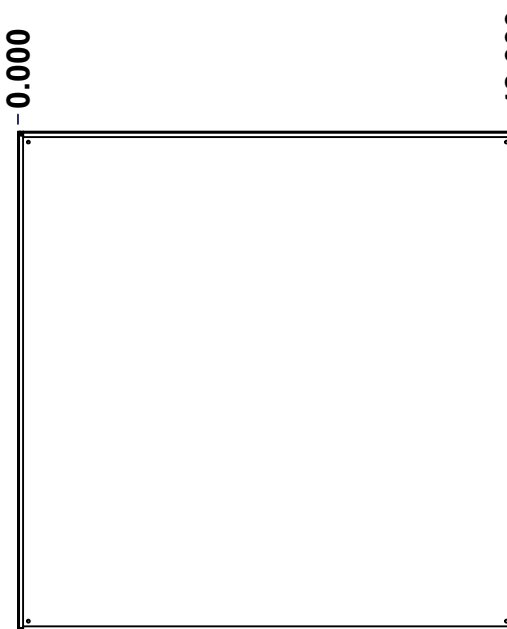

FRONT

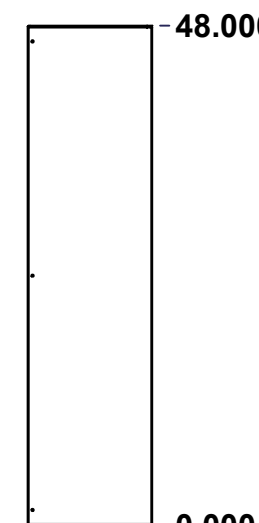

RIGHT

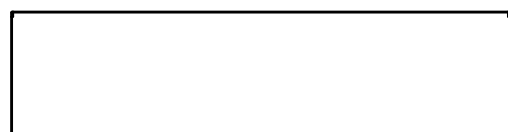

BOTTOM

No.	Revisions	Date	By/Par

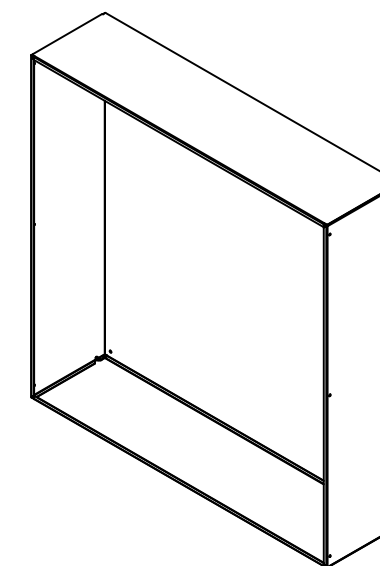

Isometric View



Tél: (450) 979-4373  
 Fax: (450) 979-4626  
[www.exmweb.com](http://www.exmweb.com)

Flatness  
Aplatissement

Max 3.0mm

Projection



Customer Client	Date
Drawn By / Dessiné Par: BoxCad: BoxCad	Date: 1/28/2014
Material / Matière: 14 Ga Cold Rolled A1008 CS Type B (1.7mm)	
Color / Couleur: Asa-61 Grey	Finish / Fini: Smooth
Description: 1100EN 48" x 48" x 12" Body	Detail Rev.
Part Number / Numéro Pièce: <b>1100EDD484812NB</b>	Rev. 0

SEE BILL OF MATERIAL ON LAST PAGE

1 / 7

This drawing is confidential and must not be reproduced or used without the consent of EXM

Ce dessin est confidentiel et ne doit pas être reproduit ou utilisé sans le consentement de EXM

STANDARD FEATURES ARE NOT LISTED IN THIS HOLE TABLE			
HOLE TABLE - BACK VIEW (CUSTOM FEATURE ONLY)			
CUT-OUT	XDIM	YDIM	DESCRIPTION
1	47.000	1.000	RND Ø0.290
2	47.000	47.000	RND Ø0.290
3	1.000	47.000	RND Ø0.290
4	1.000	1.000	RND Ø0.290

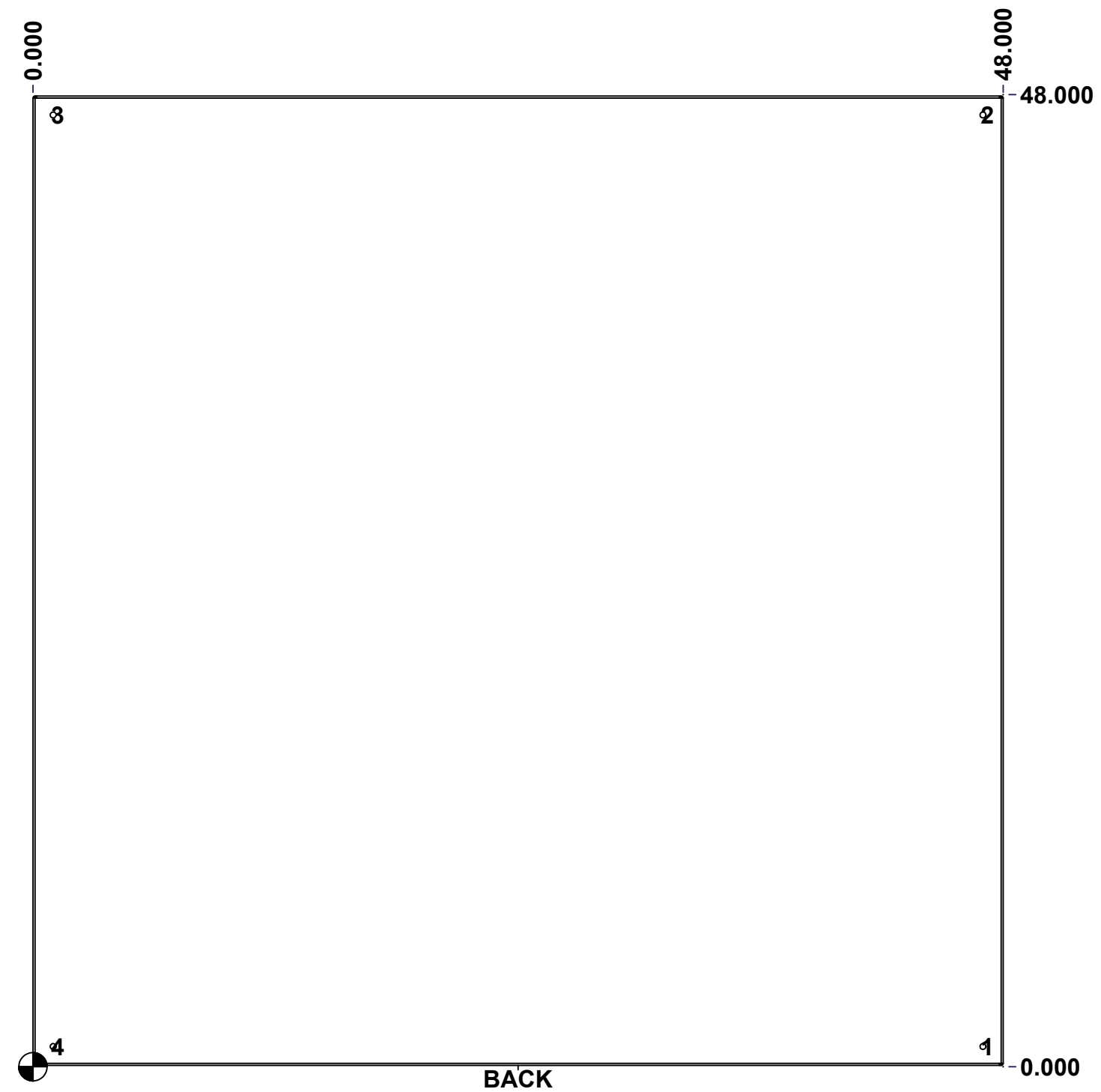

	Description	Status	
	1100EN 48" x 48" x 12" Body	(NULL)	
	Part Number Numéro Pièce	Rev.	
	<b>1100EDD484812NB</b>	<b>0</b>	6 7

This drawing is confidential and must not be reproduced or used without the consent of EXM

Ce dessin est confidentiel et ne doit pas être reproduit ou utilisé sans le consentement de EXM

No.	Revisions	Date	By/Par

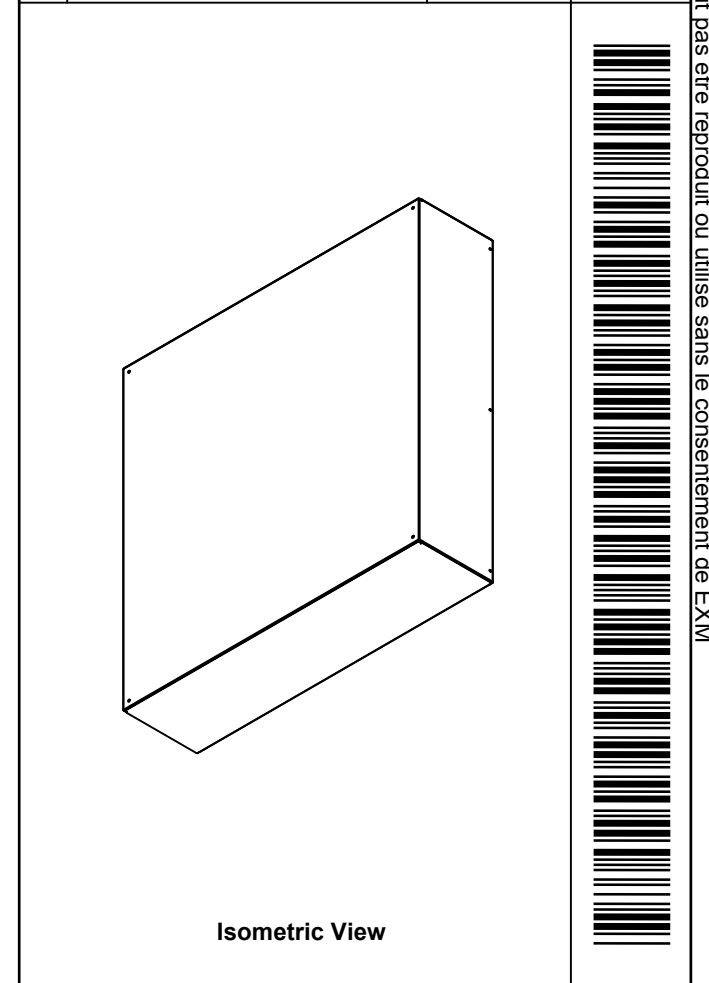

Isometric View

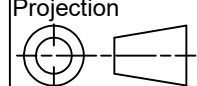
 Tél: (450) 979-4373 Fax: (450) 979-4626 <a href="http://www.exmweb.com">www.exmweb.com</a>		Flatness Aplatissement Max 3.0mm Projection 
Customer Client	Date	
Drawn By Dessiné Par	BoxCad: BoxCad	Date 1/28/2014
Material Matière	14 Ga Cold Rolled A1008 CS Type B (1.7mm)	
Color Couleur	Asa-61 Grey	Finish Fini Smooth
Description		Detail Rev.
1100EN 48" x 48" x 12" Body		
Part Number Numéro Pièce	Rev.	7
<b>1100EDD484812NB</b>	<b>0</b>	<b>7</b>

Qty	Part Number	Rev	Description
1	STK-P-02400S	0	Powder Paint (Asa-61 Grey / Smooth)
1	1100EDD484812NT-P	0	1100EN 48" x 48" x 12" Body Part
1	1100EDD484812NBT-P	0	1100EN 48" x 48" x 12" Body Part
1	1100EDD484812NB-P	0	1100EN 48" x 48" x 12" Body Part
Parts List			

This drawing is confidential and must not be reproduced or used without the consent of EXM

Ce dessin est confidentiel et ne doit pas être reproduit ou utilisé sans le consentement de EXM

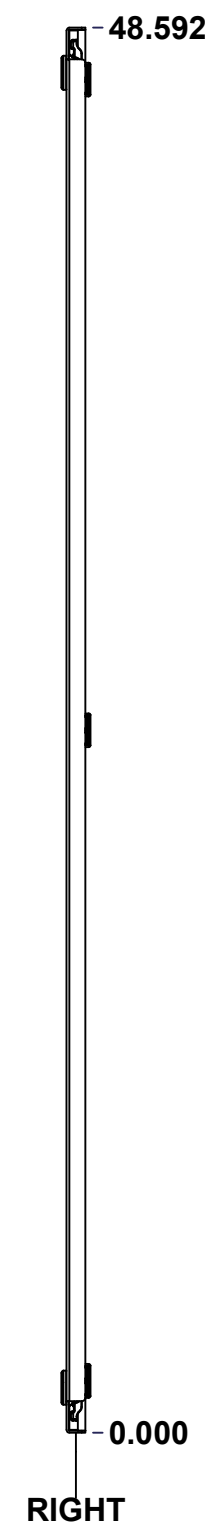
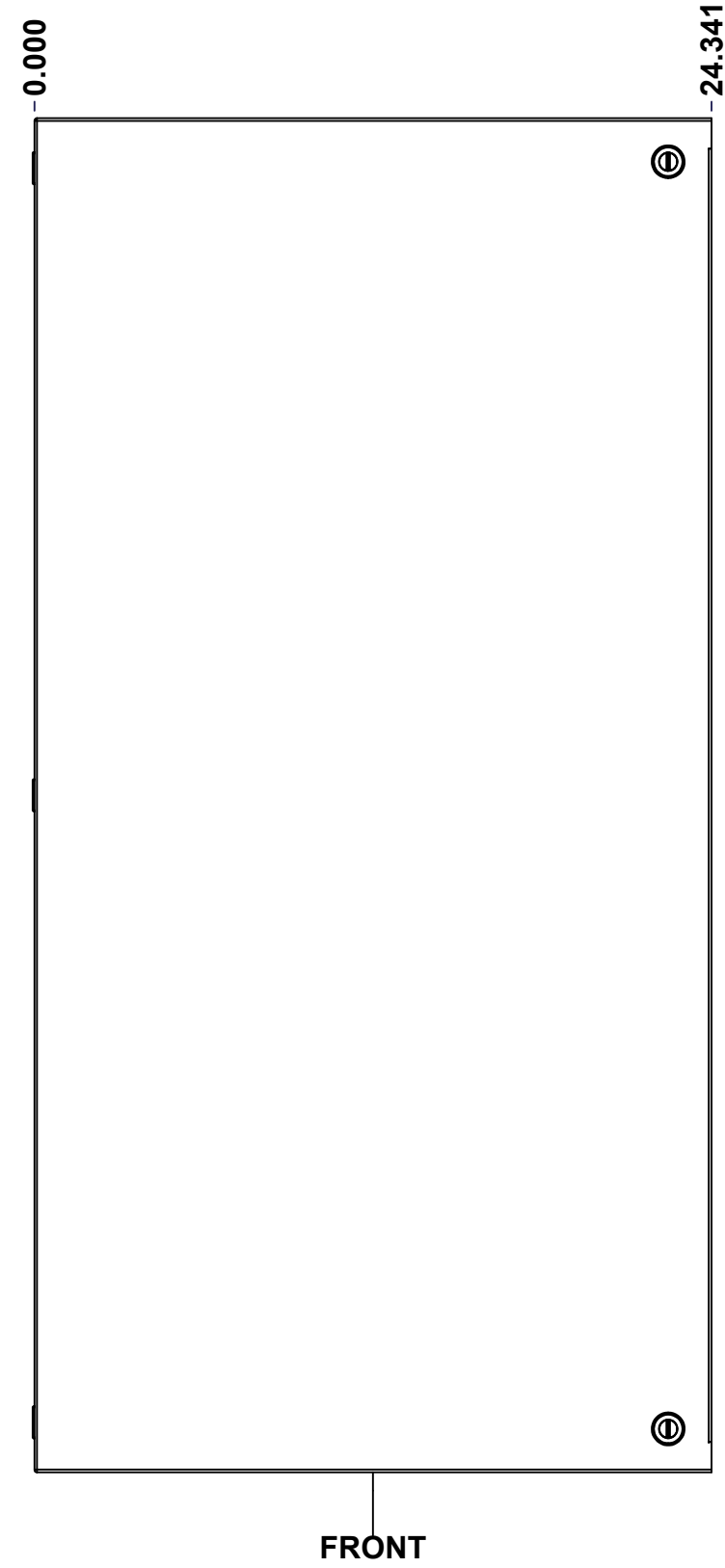
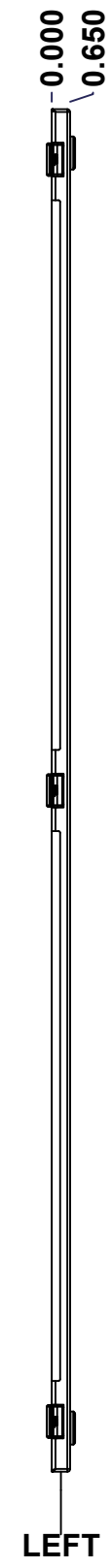
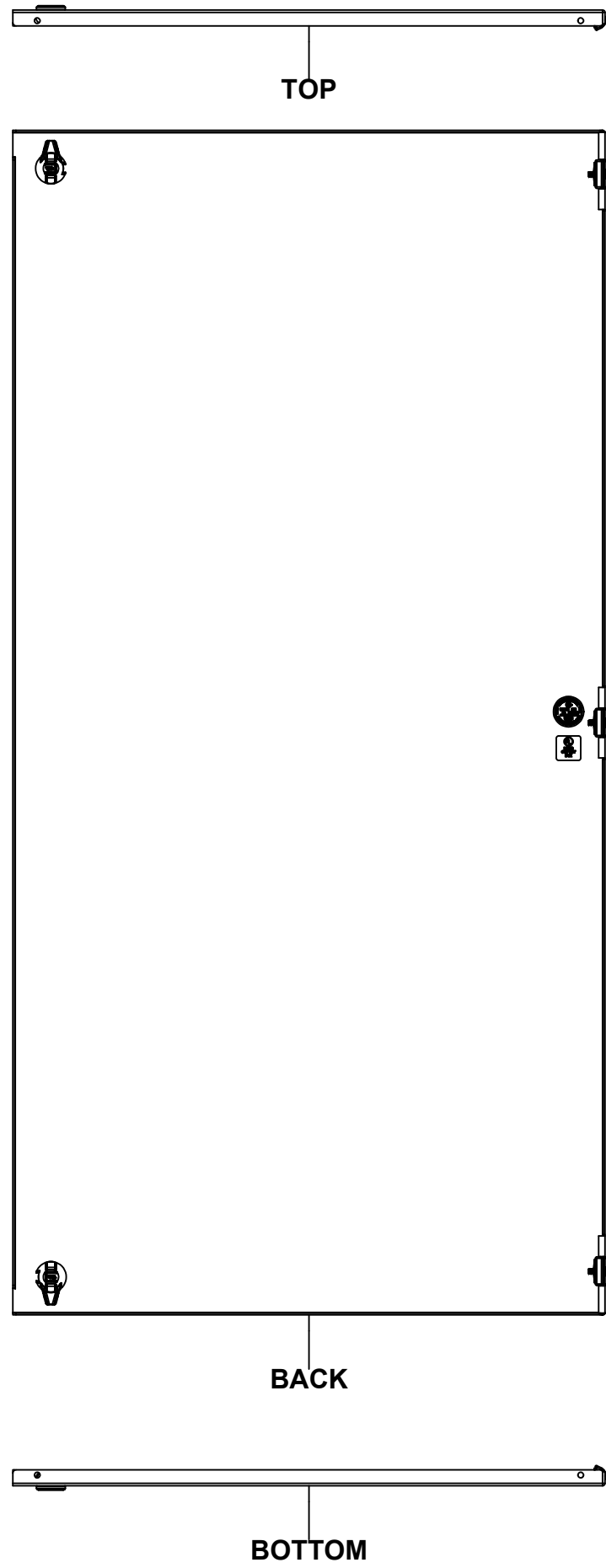

No.	Revisions	Date	By/Par

Isometric View

<p>Tél: (450) 979-4373                  Fax: (450) 979-4626  <a href="http://www.exmweb.com">www.exmweb.com</a></p>		Flatness Aplatissement			
		Max 3.0mm			
Customer Client		Projection			
Date					
Drawn By Dessiné Par BoxCad: BoxCad		Date 1/28/2014			
Material Matière 14 Ga Cold Rolled A1008 CS Type B (1.7mm)					
Color Couleur Asa-61 Grey		Finish Fini Smooth			
Description 1100EN 48" x 48" Lock Cover		Detail Rev.			
Part Number Numéro Pièce <b>1100EDD484812NLD</b>		Rev. <b>0</b>	<table border="1" style="width: 100%;"> <tr> <td style="width: 50%;">1</td> <td style="width: 50%;">3</td> </tr> </table>	1	3
1	3				

SEE BILL OF MATERIAL ON LAST PAGE

This drawing is confidential and must not be reproduced or used without the consent of EXM

Ce dessin est confidentiel et ne doit pas être reproduit ou utilisé sans le consentement de EXM

STANDARD FEATURES ARE NOT LISTED IN THIS HOLE TABLE			
HOLE TABLE - FRONT VIEW (CUSTOM FEATURE ONLY)			
CUT-OUT	XDIM	YDIM	DESCRIPTION
1	22.779	47.030	LOCK 880 SCQ1-SL @ 90.0°
2	22.779	1.562	LOCK 880 SCQ1-SL @ 270.0°

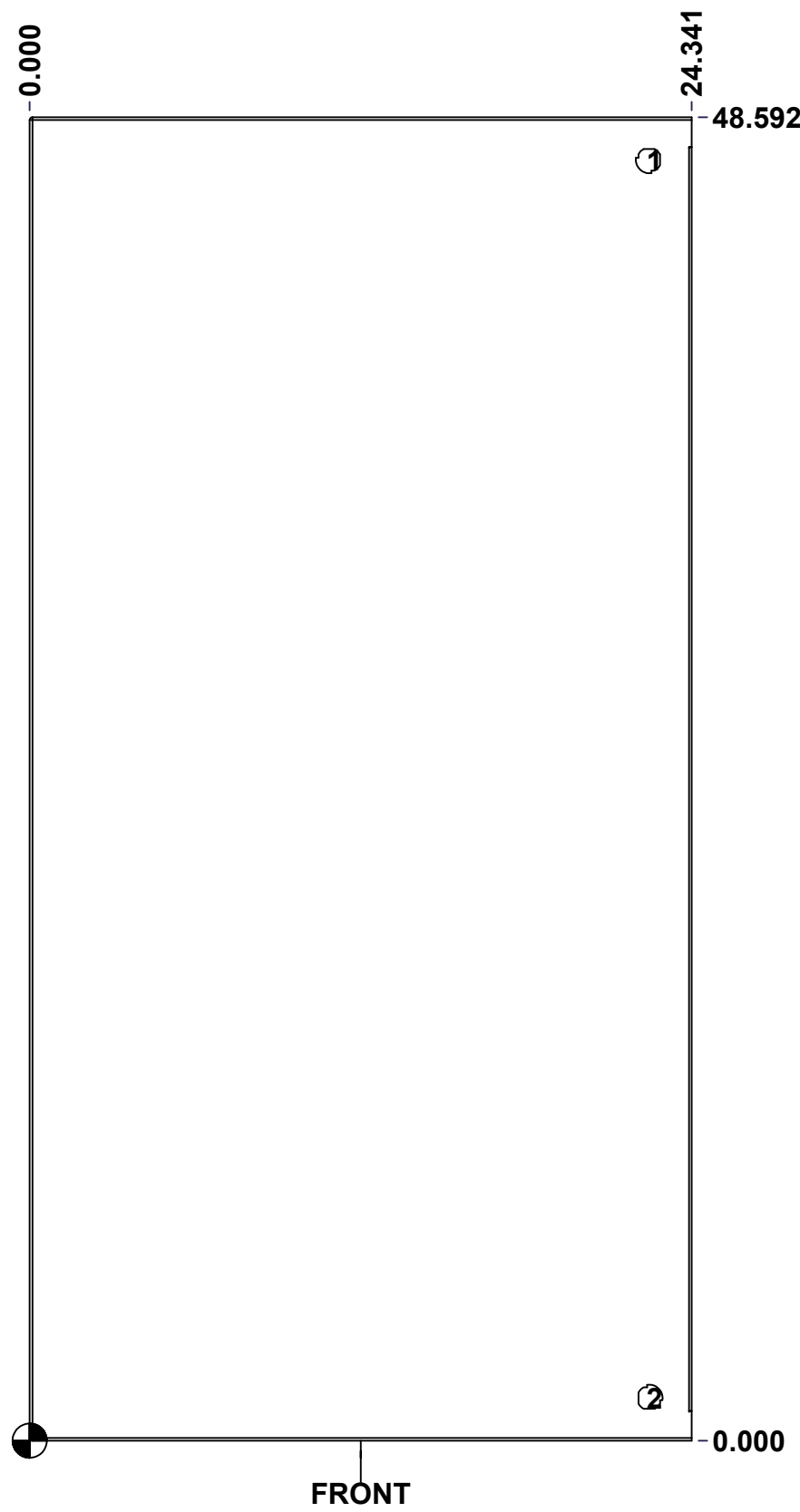



	Description		Status
	1100EN 48" x 48" x 12" Lock Cover		(NULL)
Part Number Numéro Pièce		Rev.	2
<b>1100EDD484812NLC</b>		<b>0</b>	3

This drawing is confidential and must not be reproduced or used without the consent of EXM

Ce dessin est confidentiel et ne doit pas être reproduit ou utilisé sans le consentement de EXM

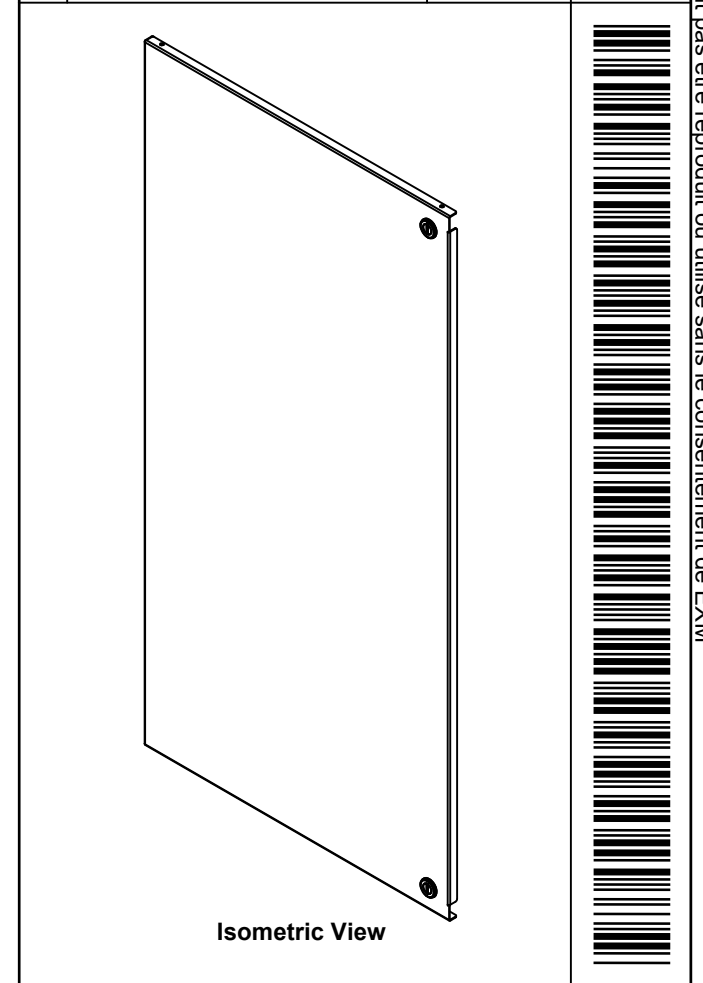
No.	Revisions	Date	By/Par

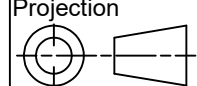

 Tél: (450) 979-4373 Fax: (450) 979-4626 <a href="http://www.exmweb.com">www.exmweb.com</a>		Flatness Aplatissement Max 3.0mm Projection 
Customer Client	Date	
Drawn By Dessiné Par	BoxCad: BoxCad	Date 1/28/2014
Material Matière	14 Ga Cold Rolled A1008 CS Type B (1.7mm)	
Color Couleur	Asa-61 Grey	Finish Fini Smooth
Description		Detail Rev.
1100EN 48" x 48" Lock Cover		
Part Number Numéro Pièce	Rev. 0	3
<b>1100EDD484812NLD</b>		<b>3</b>

1	STK-S-00800	2	CSA Electrical Box Sticker
1	STK-S-00900	0	UL Cut-Out Box Sticker
1	1100EDD484812NLC-P	0	1100EN 48" x 48" x 12" Lock Cover Part
1	STK-P-02400S	0	Powder Paint (Asa-61 Grey / Smooth)
3	STK-A-33033	4	5412 ESMCH Hinge
2	880 SCQ1-SL	0	1100 1/4 Turn Lock
Qty	Part Number	Rev	Description
Parts List			



This drawing is confidential and must not be reproduced or used without the consent of EXM

Ce dessin est confidentiel et ne doit pas être reproduit ou utilisé sans le consentement de EXM

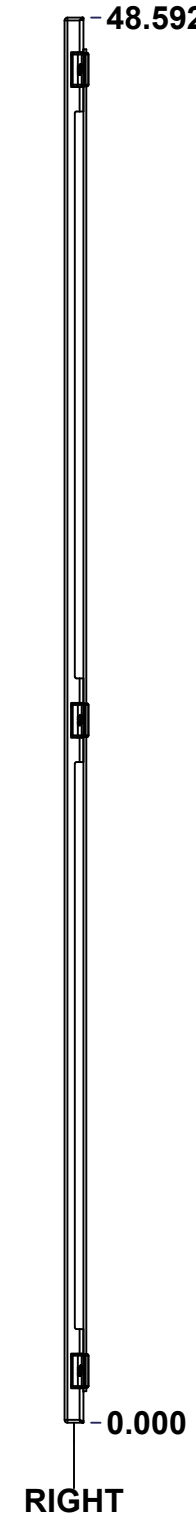
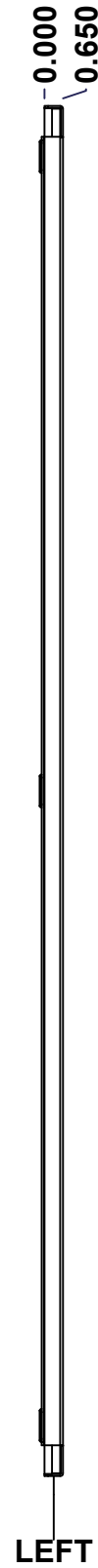
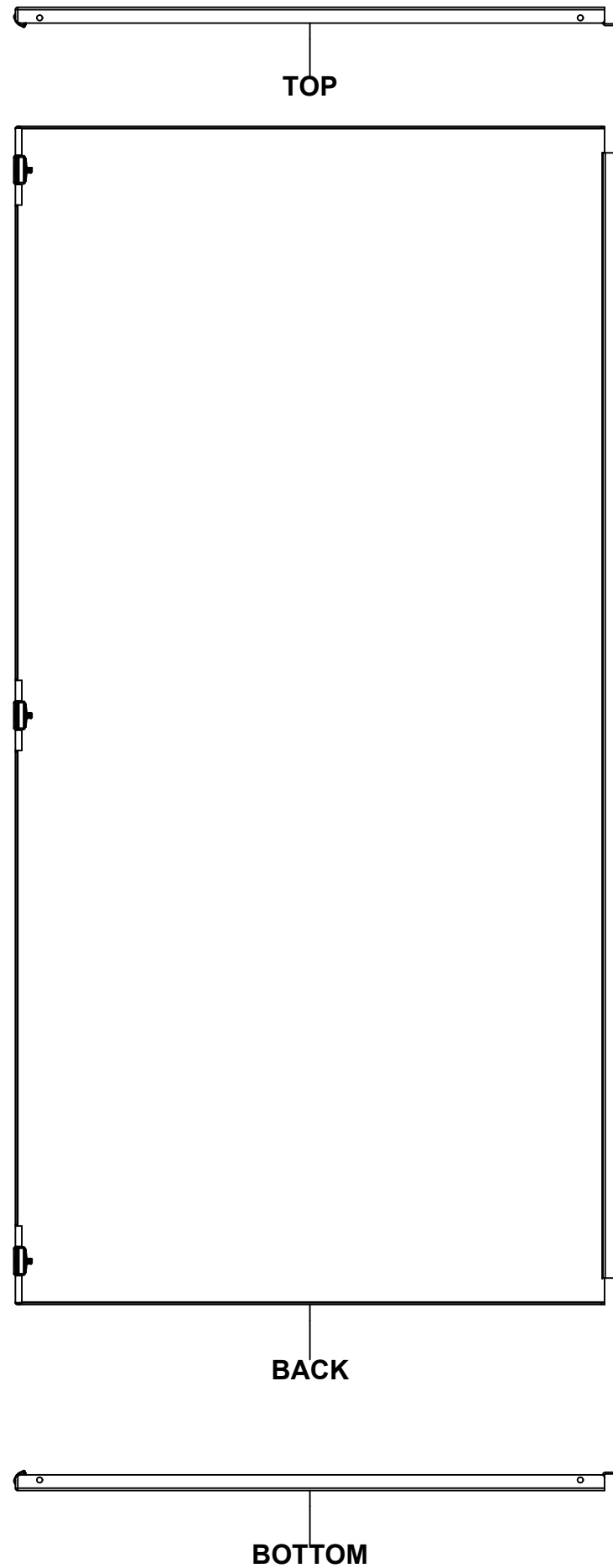

No.	Revisions	Date	By/Par

Isometric View

Tél: (450) 979-4373 Fax: (450) 979-4626 <a href="http://www.exmweb.com">www.exmweb.com</a>		Flatness Aplatissement	
		Max 3.0mm	
Customer Client		Projection	
Date			
Drawn By Dessiné Par BoxCad: BoxCad		Date 1/28/2014	
Material Matière 14 Ga Cold Rolled A1008 CS Type B (1.7mm)			
Color Couleur Asa-61 Grey		Finish Fini Smooth	
Description 1100EN 48" x 48" Flange Cover			Detail Rev.
Part Number Numéro Pièce <b>1100EDD484812NFD</b>		Rev. <b>0</b>	1 / 3

SEE BILL OF MATERIAL ON LAST PAGE

This drawing is confidential and must not be reproduced or used without the consent of EXM

Ce dessin est confidentiel et ne doit pas être reproduit ou utilisé sans le consentement de EXM

No.	Revisions	Date	By/Par

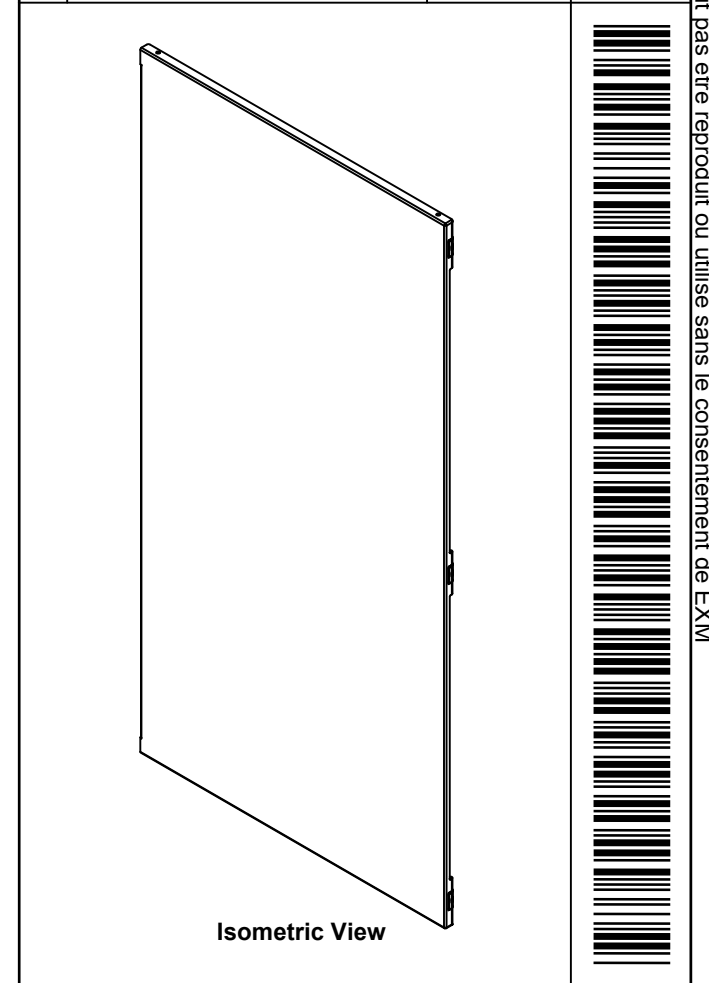

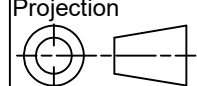
 Tél: (450) 979-4373 Fax: (450) 979-4626 <a href="http://www.exmweb.com">www.exmweb.com</a>		Flatness Aplatissement Max 3.0mm Projection 
Customer Client	Date	
Drawn By Dessiné Par	BoxCad: BoxCad	Date 1/28/2014
Material Matière	14 Ga Cold Rolled A1008 CS Type B (1.7mm)	
Color Couleur	Asa-61 Grey	Finish Fini Smooth
Description		Detail Rev.
1100EN 48" x 48" Flange Cover		
Part Number Numéro Pièce	Rev.	3
<b>1100EDD484812NFD</b>	<b>0</b>	<b>3</b>

Qty	Part Number	Rev	Description
1	1100EDD484812NFC-P	0	1100EN 48" x 48" x 12" Flange Cover Part
1	STK-P-02400S	0	Powder Paint (Asa-61 Grey / Smooth)
3	STK-A-33033	4	5412 ESMCH Hinge
Parts List			