

This drawing is confidential and must not be reproduced or used without the consent of EXM

Ce dessin est confidentiel et ne doit pas être reproduit ou utilisé sans le consentement de EXM

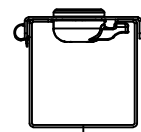

TOP

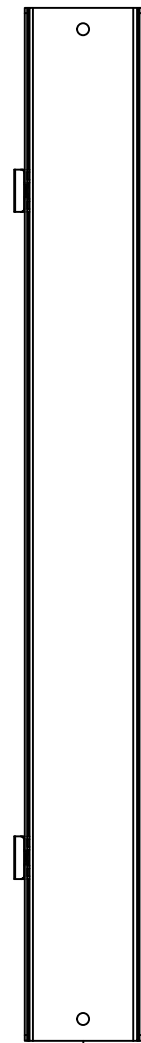

BACK

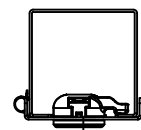

BOTTOM

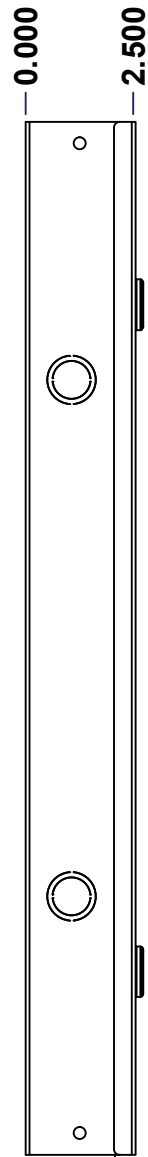

LEFT

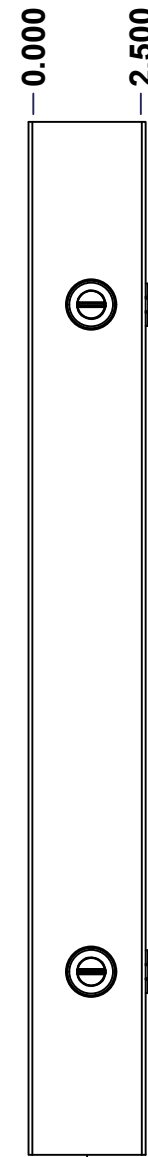

FRONT

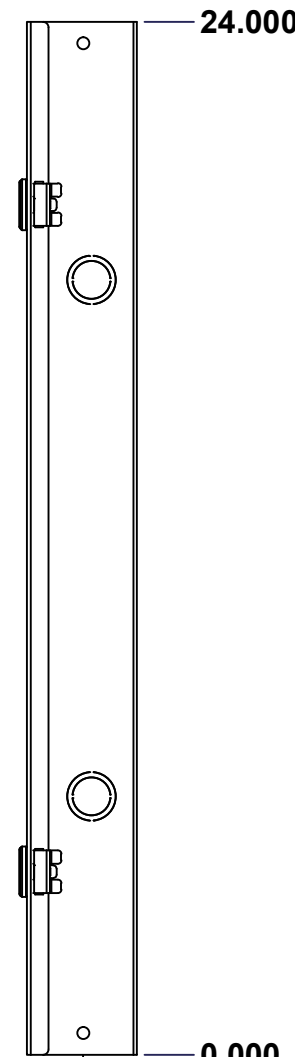

RIGHT

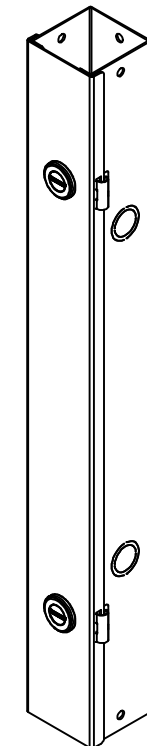

Isometric View



| No. | Revisions | Date | By/Par |
|-----|-----------|------|--------|
| | | | |
| | | | |
| | | | |
| | | | |
| | | | |

| | | |
|--|-----------------------|---------------------------|
|  Tél: (450) 979-4373 Fax: (450) 979-4626 www.exmweb.com | | Flatness Aplatissement |
| | | Max 3.0mm |
| Customer Client | | Date |
| Drawn By Dessiné Par BoxCad: BoxCad | | Date 18-Jan-23 |
| Material Matière 16 Ga Cold Rolled A1008 CS Type B (1.4mm) | | |
| Color Couleur Asa-61 Grey | Finish Fini Smooth | |
| Description 1100SS 24" x 2.5" x 2.5" Assembly | | Detail Rev. |
| Part Number Numéro Pièce 1100SS2024 | | Rev. 1 0 |

SEE BILL OF MATERIAL ON LAST PAGE

1100SS2024

Rev. 1
0

This drawing is confidential and must not be reproduced or used without the consent of EXM

Ce dessin est confidentiel et ne doit pas être reproduit ou utilisé sans le consentement de EXM

| NOTE | |
|------|------------------|
| ITEM | DESCRIPTION |
| 1 | NEMA 1 Enclosure |

| No. | Revisions | Date | By/Par |
|-----|-----------|------|--------|
| | | | |
| | | | |
| | | | |
| | | | |

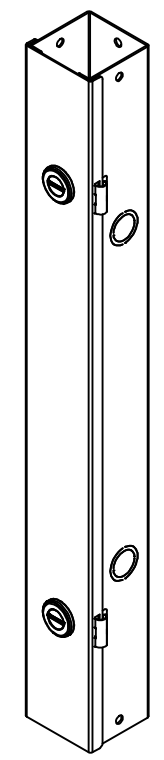

Isometric View

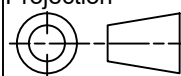
| | |
|--|---|
|  Tél: (450) 979-4373 Fax: (450) 979-4626 www.exmweb.com | Flatness Aplatissement Max 3.0mm |
| | Projection  |
| Customer Client | Date |
| Drawn By Dessiné Par BoxCad: BoxCad | Date 18-Jan-23 |
| Material Matière 16 Ga Cold Rolled A1008 CS Type B (1.4mm) | |
| Color Couleur Asa-61 Grey | Finish Fini Smooth |

| PACKING | | |
|-----------------------|-----|--|
| ITEM | QTY | DESCRIPTION |
| Cardboard sleeve | 2 | Top and Bottom |
| Plastic strap - Black | 2 | To Squeeze 2 cardboard sleeve together |
| Packaging label | 3 | White label with PN |

| Qty | Part Number | Rev | Description |
|------------|-------------|-----|-------------------------------|
| 1 | 1100SS2024C | 0 | 1100SS 24" x 2.5" Cover |
| 1 | 1100SS2024B | 0 | 1100SS 24" x 2.5" x 2.5" Body |
| Parts List | | | |

| | | | |
|--|--|------------------|--------|
| Description 1100SS 24" x 2.5" x 2.5" Assembly | | Detail Rev. | |
| Part Number Numéro Pièce 1100SS2024 | | Rev. 0 | 2 7 |

This drawing is confidential and must not be reproduced or used without the consent of EXM

Ce dessin est confidentiel et ne doit pas être reproduit ou utilisé sans le consentement de EXM

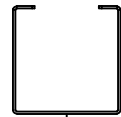

TOP

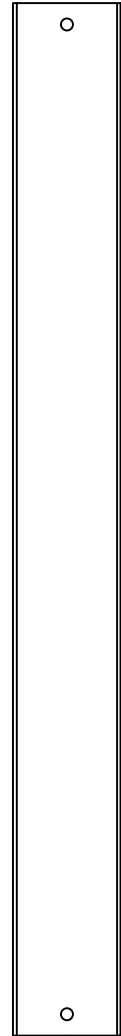

BACK

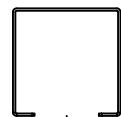

BOTTOM

0.000
2.500

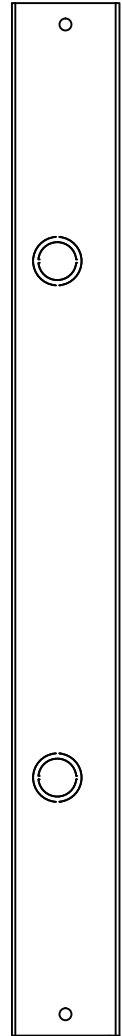

LEFT

0.000
2.500

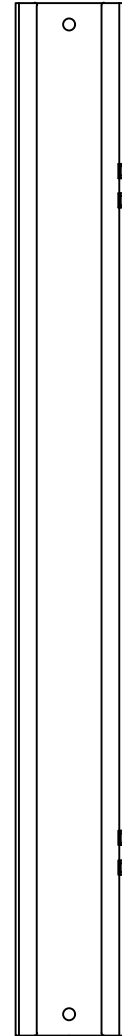

FRONT

24.000

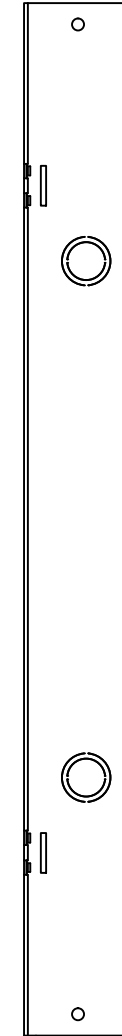

RIGHT

0.000

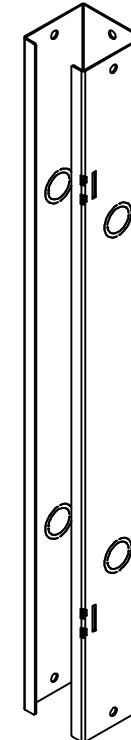

Isometric View



| No. | Revisions | Date | By/Par |
|-----|-----------|------|--------|
| | | | |
| | | | |
| | | | |
| | | | |
| | | | |

| | | |
|--|---|--|
| Tél: (450) 979-4373 Fax: (450) 979-4626 www.exmweb.com | | Flatness Aplatissement Max 3.0mm Projection |
| Customer Client | Date | |
| Drawn By Dessiné Par | BoxCad: BoxCad | Date 18-Jan-23 |
| Material Matière | 16 Ga Cold Rolled A1008 CS Type B (1.4mm) | |
| Color Couleur | Asa-61 Grey | Finish Fini Smooth |
| Description | Detail Rev. | |
| 1100SS 24" x 2.5" x 2.5" Body | | |
| Part Number Numéro Pièce | Rev. | 3 |
| 1100SS2024B | 0 | 7 |

SEE BILL OF MATERIAL ON LAST PAGE

This drawing is confidential and must not be reproduced or used without the consent of EXM

Ce dessin est confidentiel et ne doit pas être reproduit ou utilisé sans le consentement de EXM

| No. | Revisions | Date | By/Par |
|-----|-----------|------|--------|
| | | | |
| | | | |
| | | | |
| | | | |
| | | | |

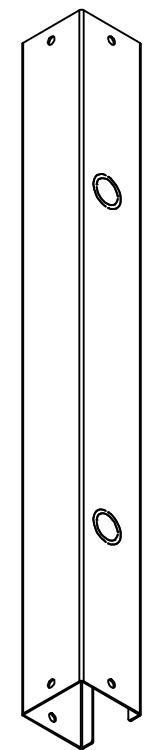

Isometric View

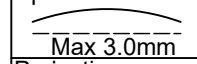

| | | |
|--|-----------------------|---|
|  Tél: (450) 979-4373 Fax: (450) 979-4626 www.exmweb.com | | Flatness Aplatissement  Max 3.0mm |
| Customer Client | | Date |
| Drawn By / Dessiné Par: BoxCad: BoxCad | | Date: 18-Jan-23 |
| Material / Matière: 16 Ga Cold Rolled A1008 CS Type B (1.4mm) | | |
| Color / Couleur: Asa-61 Grey | Finish / Fini: Smooth | |
| Description: 1100SS 24" x 2.5" x 2.5" Body | | Detail Rev. |
| Part Number / Numéro Pièce: 1100SS2024B | | Rev. 4 / 7 |

| Qty | Part Number | Rev | Description |
|------------|---------------|-----|-------------------------------------|
| 1 | STK-P-02400S | 0 | Powder Paint (Asa-61 Grey / Smooth) |
| 1 | 1100SS2024B-P | 0 | 1100SS 24" x 2.5" x 2.5" Body Part |
| Parts List | | | |

This drawing is confidential and must not be reproduced or used without the consent of EXM

Ce dessin est confidentiel et ne doit pas être reproduit ou utilisé sans le consentement de EXM

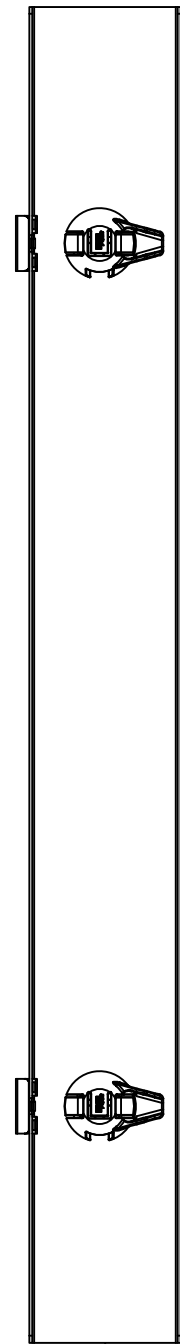
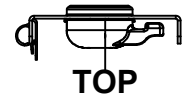

BACK



BOTTOM

0.000
0.500



LEFT

0.000
2.720

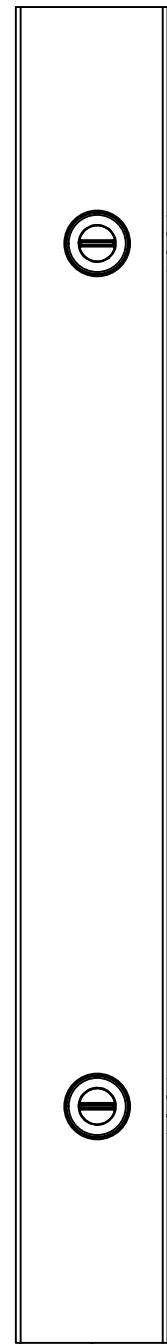

FRONT

24.000

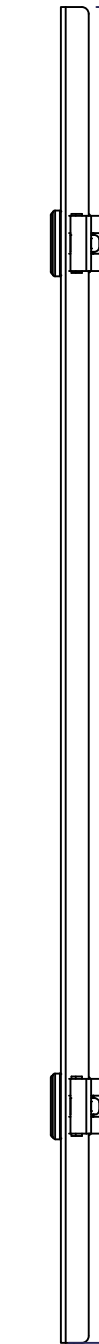

RIGHT

0.000

| No. | Revisions | Date | By/Par |
|-----|-----------|------|--------|
| | | | |
| | | | |
| | | | |
| | | | |
| | | | |

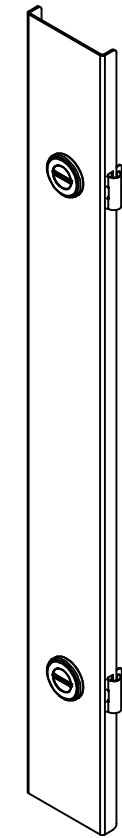

Isometric View



Tél: (450) 979-4373
Fax: (450) 979-4626
www.exmweb.com

Flatness
Aplatissement

Max 3.0mm

Projection

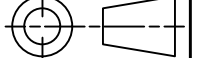

| | |
|---|-----------------|
| Customer Client | Date |
| Drawn By / Dessiné Par: BoxCad: BoxCad | Date: 18-Jan-23 |
| Material / Matière: 16 Ga Cold Rolled A1008 CS Type B (1.4mm) | |

| | |
|------------------------------|-----------------------|
| Color / Couleur: Asa-61 Grey | Finish / Fini: Smooth |
|------------------------------|-----------------------|

| | |
|--------------------------------------|-------------|
| Description: 1100SS 24" x 2.5" Cover | Detail Rev. |
|--------------------------------------|-------------|

| | | |
|---|--------|-------|
| Part Number / Numéro Pièce: 1100SS2024C | Rev. 0 | 5 / 7 |
|---|--------|-------|

SEE BILL OF MATERIAL ON LAST PAGE

This drawing is confidential and must not be reproduced or used without the consent of EXM

Ce dessin est confidentiel et ne doit pas être reproduit ou utilisé sans le consentement de EXM

| STANDARD FEATURES ARE NOT LISTED IN THIS HOLE TABLE | | | |
|---|-------|--------|---------------------------|
| HOLE TABLE - FRONT VIEW (CUSTOM FEATURE ONLY) | | | |
| CUT-OUT | XDIM | YDIM | DESCRIPTION |
| 1 | 1.260 | 19.750 | LOCK 880 SCQ1-SL @ 180.0° |
| 2 | 1.260 | 4.250 | LOCK 880 SCQ1-SL @ 180.0° |

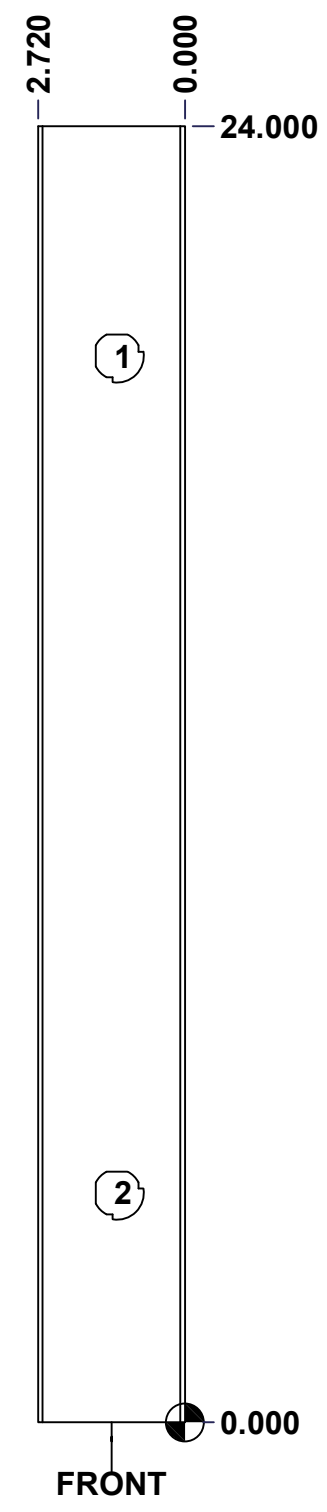

| | | | |
|--|--------------------------------|----------|-------|
| | Description | Status | |
| | 1100SS 24" x 2.5" x 2.5" Cover | (NULL) | |
| | Part Number Numéro Pièce | Rev. | |
| | 1100SS2024C | 0 | 6 / 7 |

This drawing is confidential and must not be reproduced or used without the consent of EXM

Ce dessin est confidentiel et ne doit pas être reproduit ou utilisé sans le consentement de EXM

| No. | Revisions | Date | By/Par |
|-----|-----------|------|--------|
| | | | |
| | | | |
| | | | |
| | | | |
| | | | |

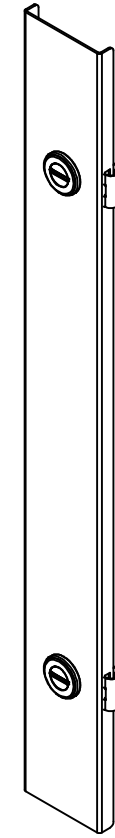

Isometric View

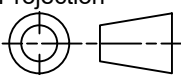

| | | |
|--|-----------------------|---|
|  Tél: (450) 979-4373 Fax: (450) 979-4626 www.exmweb.com | | Flatness Aplatissement Max 3.0mm Projection  |
| Customer Client | Date | |
| Drawn By / Dessiné Par: BoxCad: BoxCad | Date: 18-Jan-23 | |
| Material / Matière: 16 Ga Cold Rolled A1008 CS Type B (1.4mm) | | |
| Color / Couleur: Asa-61 Grey | Finish / Fini: Smooth | |
| Description: 1100SS 24" x 2.5" Cover | | Detail Rev. |
| Part Number / Numéro Pièce: 1100SS2024C | | Rev. 7 |
| | | 0 7 |

| Qty | Part Number | Rev | Description |
|------------|---------------|-----|-------------------------------------|
| 2 | STK-Q-33361 | 0 | Spring Steel Hinge |
| 1 | STK-P-02400S | 0 | Powder Paint (Asa-61 Grey / Smooth) |
| 1 | 1100SS2024C-P | 0 | 1100SS 24" x 2.5" x 2.5" Cover Part |
| 2 | 880 SCQ1-SL | 0 | 1100 1/4 Turn Lock |
| Parts List | | | |