

This drawing is confidential and must not be reproduced or used without the consent of EXM

Ce dessin est confidentiel et ne doit pas être reproduit ou utilisé sans le consentement de EXM

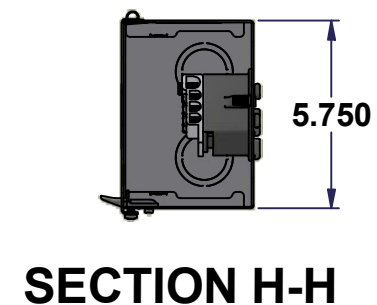

No.	Revisions	Date	By/Par
1	Redraw Model	11/08/2008	MichelP
2	Change Qty. tab on 400 & 600 AMP	08/12/2008	MichelP
3	Change for new hinge & change K-O size on 200 AMP	19/10/2009	MichelP
4	Turn into iLogic	20/4/2010	MichelP
5	Change sticker position and ground shape from 1.250 to 0.500	30/08/2010	AllenL

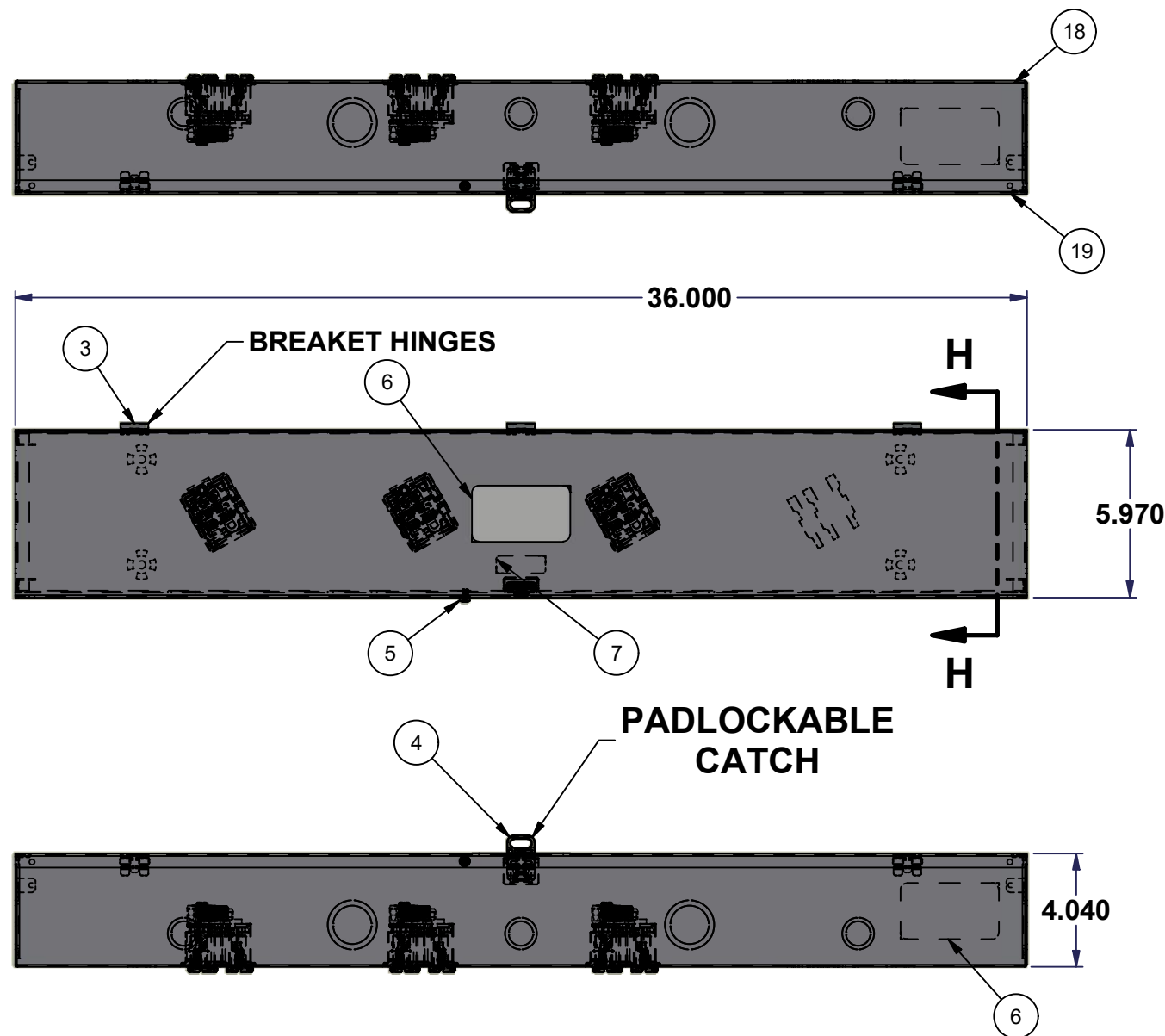
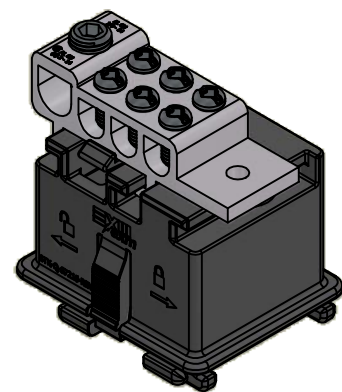
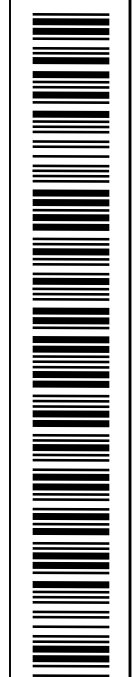
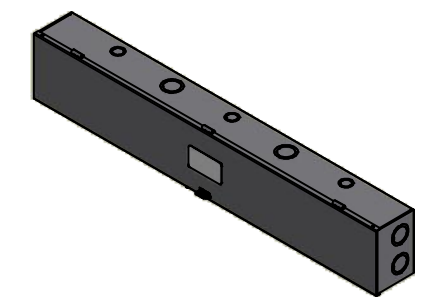

		Tél: (450) 979-4373 Fax: (450) 979-4626 www.exmweb.com	Flatness Aplatissement Max 3.0mm Projection
Customer Client			Date
Drawn By Dessiné Par	BoxCad: MichelP		Date Aug./3/2010
Material Matière	See Part List		
Color Couleur	See Part List	Finish Fini	See Part List
Description	1100T Assembly		Detail Rev.
Part Number Numéro Pièce	1100T_MASTER		Rev. 5

Item	Qty	Part Number	Rev.	Description	MATERIAL	Color	Finish
19	1	1100T310C-P	5	1100T310 Cover Part	16 Ga H.R.P. & O. (1.4mm)	Asa-61 Grey	Smooth
18	1	1100T3103B-P	5	1100T3103 Body Part	16 Ga H.R.P. & O. (1.4mm)	Asa-61 Grey	Smooth
14	4	STK-A-55100	0	ST125 - Splitter Block and Lug	See Part List	See Part List	See Part List
7	1	STK-S-00250	0	Sticker 1100 B/T/BT Cover	Milar	Green Writing on White	N/A
6	2	STK-S-00100	0	3.5" x 2" Silver Milar Flexcon Sticker	Milar	Silver	N/A
5	1	STK-Q-05020	5	M5 x 8mm Thread Rolling Screw	Property Class 4.8 Steel	Bright	Zinc Plated
4	1	STK-Q-77450	3	Plastic Padlock Provision	Bayer FR110	Black	Fine Textured
3	3	STK-Q-33361	0	Spring Steel Hinge	0.75mm Spring Steel	Bright	Zinc Plated

Parts List

This drawing is confidential and must not be reproduced or used without the consent of EXM

Ce dessin est confidentiel et ne doit pas être reproduit ou utilisé sans le consentement de EXM

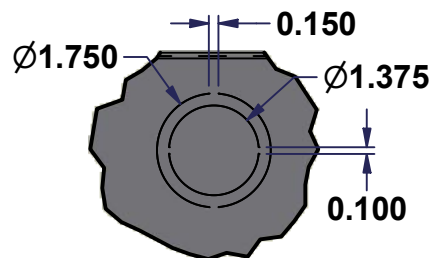

DETAIL C

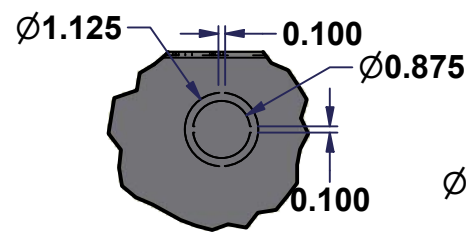

DETAIL D

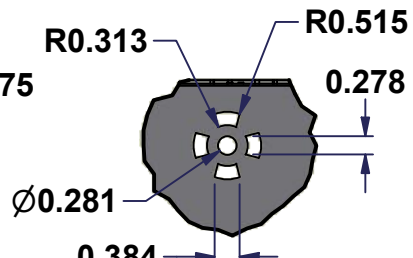

DETAIL E

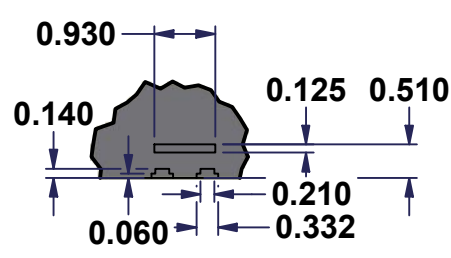

DETAIL F

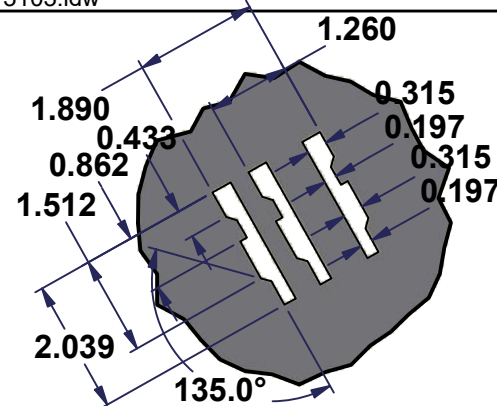

DETAIL G

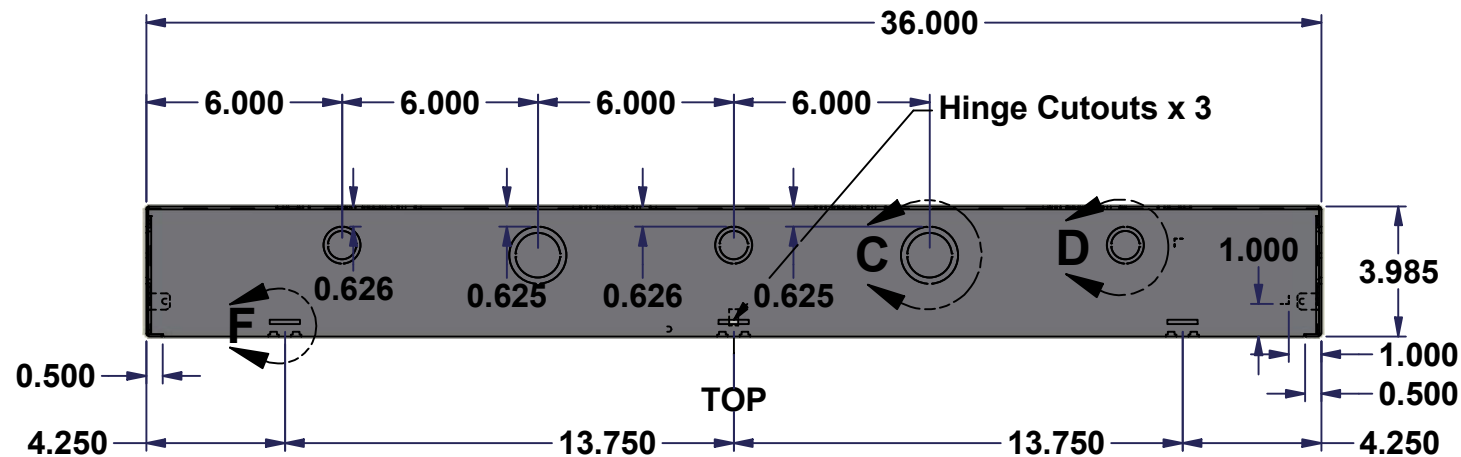

Bumper Cutouts x 4

Isolator Cutouts

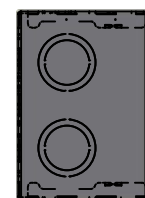

LEFT

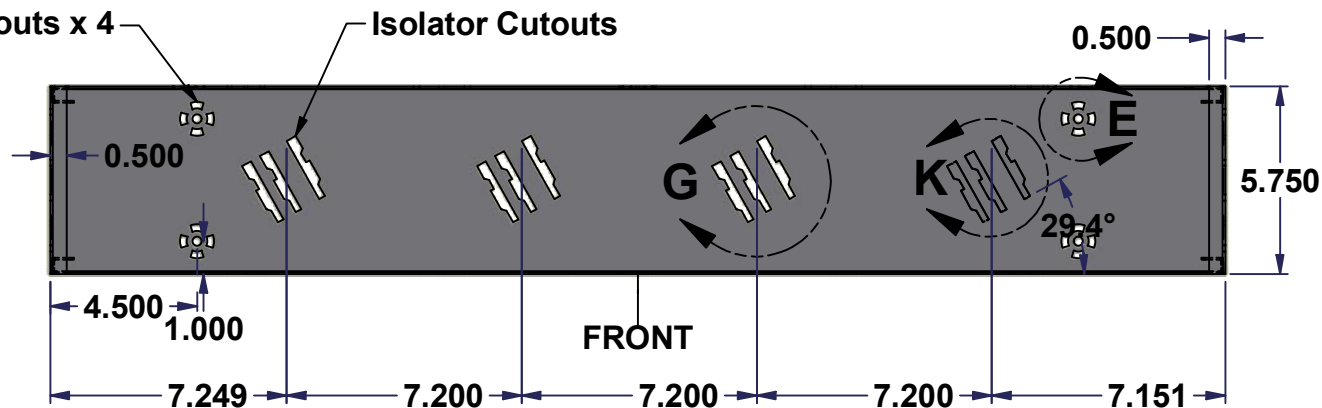

FRONT

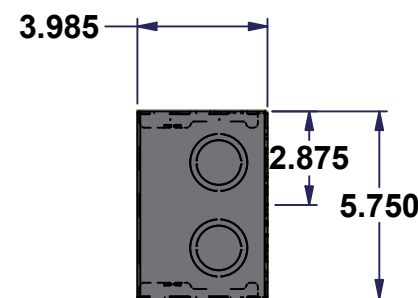

RIGHT

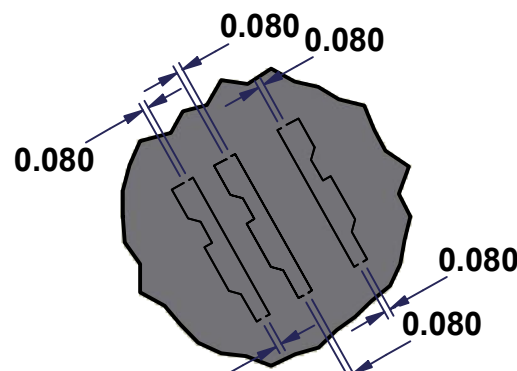

DETAIL K

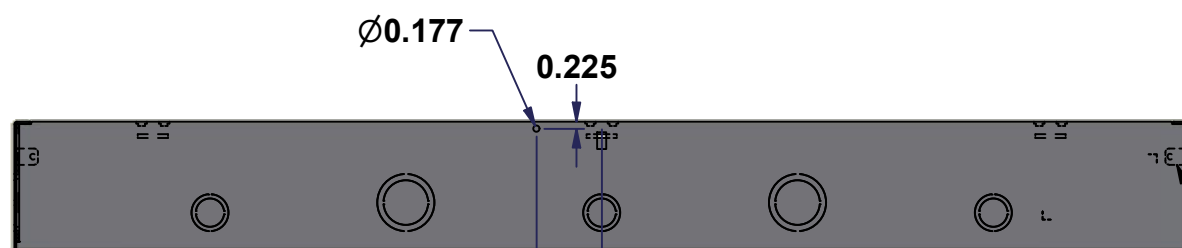

BOTTOM

Ground tab x 4

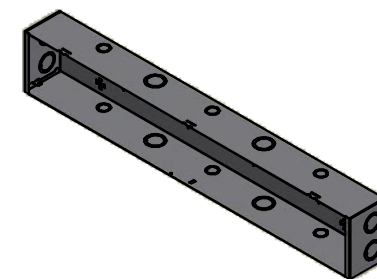

Isometric View



No.	Revisions	Date	By/Par
1	Redraw Model	11/08/2008	MichelP
2	Change Qty. tab on 400 & 600 AMP	08/12/2008	MichelP
3	Change for new hinge & change K-O size on 200 AMP	19/10/2009	MichelP
4	Turn into iLogic	21/04/2010	MichelP
5	Change sticker position and ground shape from 1.250 to 0.500	30/08/2010	AllenL

		Tél: (450) 979-4373 Fax: (450) 979-4626 www.exmweb.com		Flatness Aplatissement Max 3.0mm Projection 	
Customer Client	EXM Metal	Date		Date Aug./3/2010	
Drawn By / Dessiné Par	BoxCad: Edgar Claros	Date		Date Aug./3/2010	
Material Matière	16 Ga H.R.P. & O. (1.4mm)				
Color Couleur	Asa-61 Grey	Finish Fini	Smooth		
Description	1100T Body Part			Detail Rev.	
Part Number / Numéro Pièce	1100T_MASTER-BODY			Rev.	2
					3

ITEM	Qty	Part Number	Rev.	Description	MATERIAL	Color	Finish
1	1	1100T3103B-P	5	1100T3103 Body Part	16 Ga H.R.P. & O. (1.4mm)	Asa-61 Grey	Smooth

Parts List

This drawing is confidential and must not be reproduced or used without the consent of EXM

Ce dessin est confidentiel et ne doit pas être reproduit ou utilisé sans le consentement de EXM

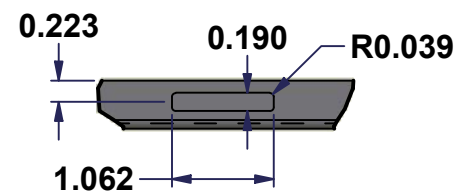
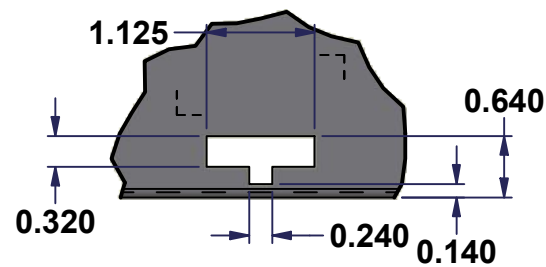
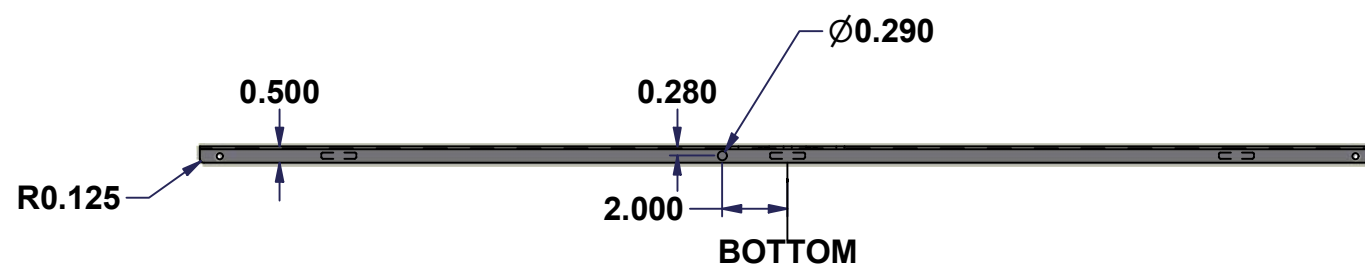
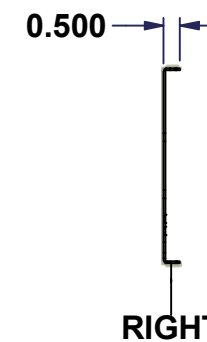
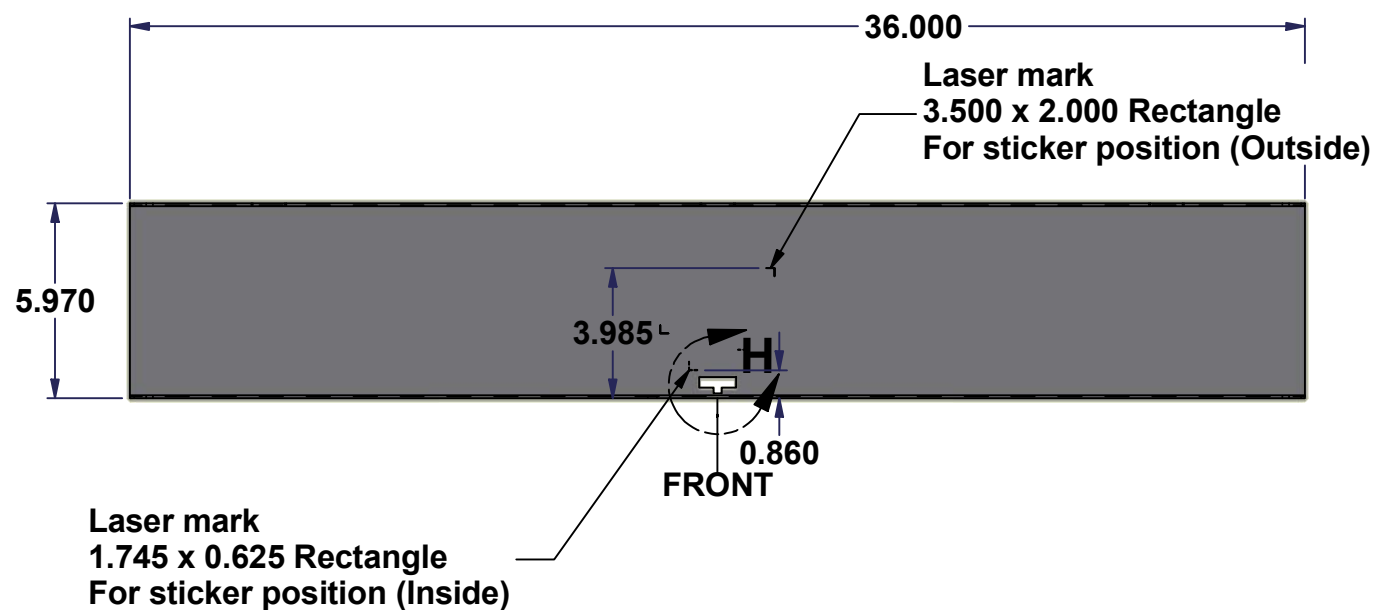
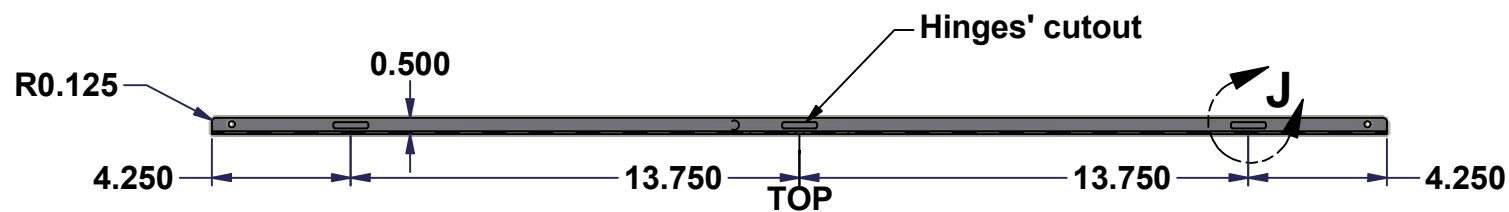

No.	Revisions	Date	By/Par
1	change Qty. tab on 400 & 600 AMP	11/08/2008	MichelP
2	change Qty. tab on 400 & 600 AMP	08/12/2008	MichelP
3	Change for new hinge & change K-O size on 200 AMP	19/10/2009	MichelP
4	Turn into iLogic	20/4/2010	MichelP
5	Change sticker position and ground shape from 1.250 to 0.500	30/08/2010	AllenL

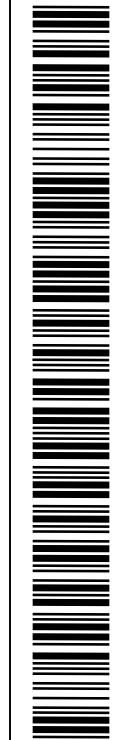
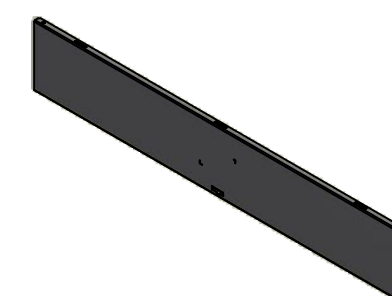

Isometric View



Tél: (450) 979-4373
Fax: (450) 979-4626
www.exmweb.com

Flatness
Aplatissement
Max 3.0mm
Projection

Customer Client	EXM Manufacturing	Date
Drawn By / Dessiné Par	BoxCad: Edgar Claros	Date Aug./3/2010

Material Matière: 16 Ga H.R.P. & O. (1.4mm)

Color Couleur	Asa-61 Grey	Finish Fini	Smooth
---------------	-------------	-------------	--------

Description: 1100T Cever Part

ITEM	Qty	Part Number	Rev.	Description	MATERIAL	Color	Finish
1	1	1100T310C-P	5	1100T310 Cover Part	16 Ga H.R.P. & O. (1.4mm)	Asa-61 Grey	Smooth

Part Number / Numéro Pièce	Rev.	3
1100T_MASTER-COVER	5	3