

This drawing is confidential and must not be reproduced or used without the consent of EXM

Ce dessin est confidentiel et ne doit pas être reproduit ou utilisé sans le consentement de EXM

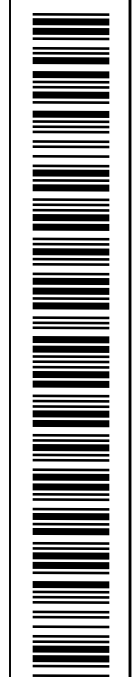
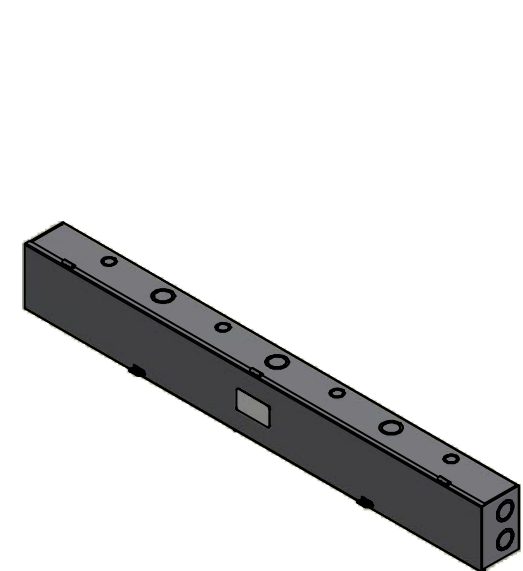
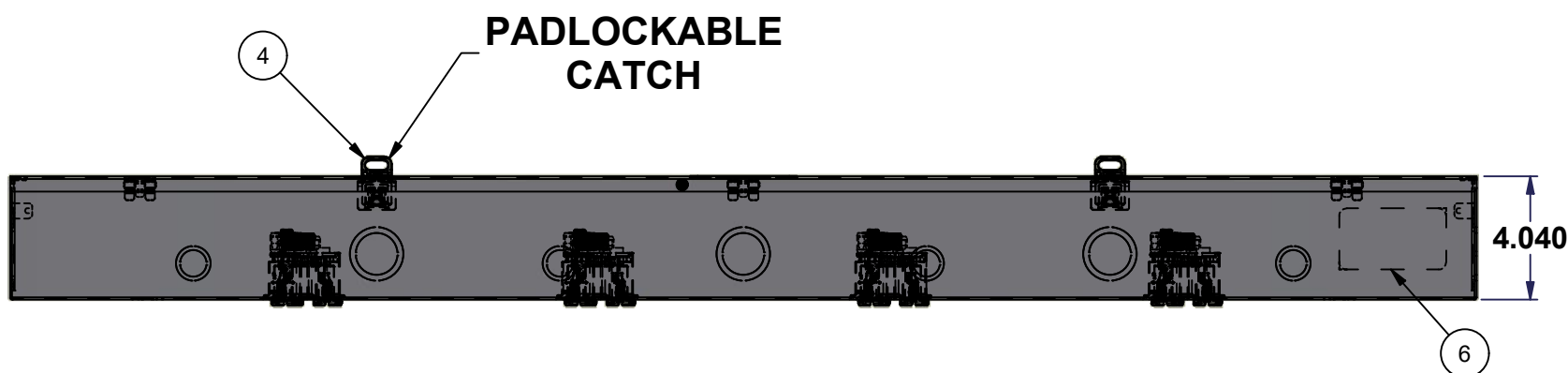
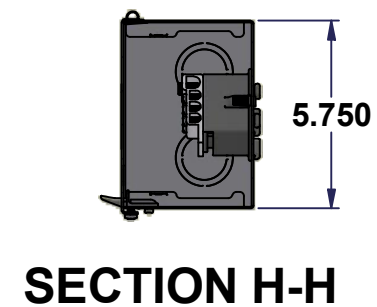
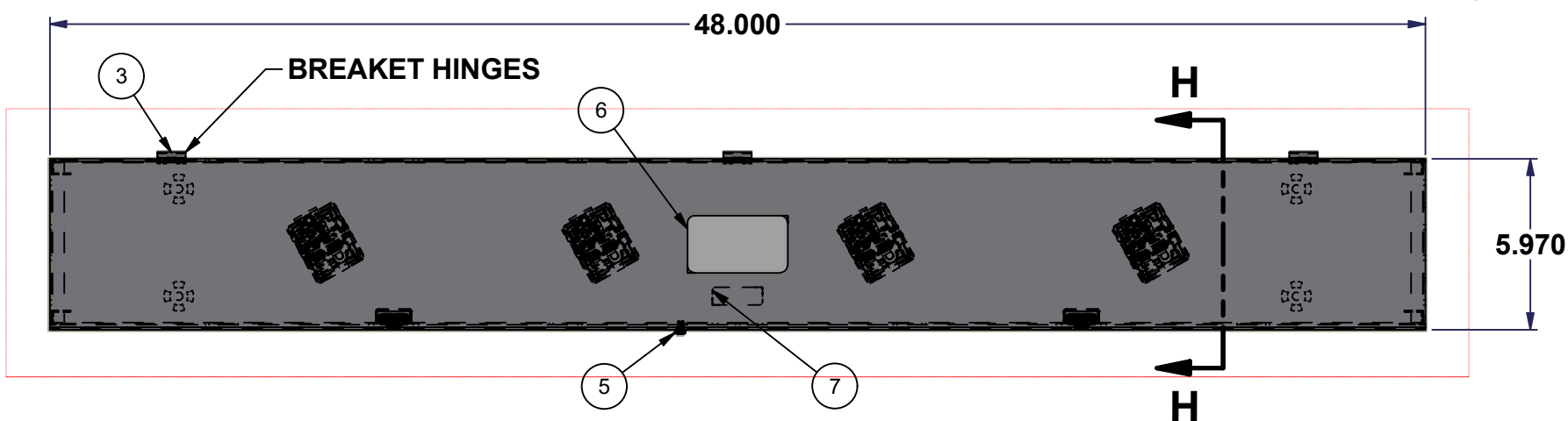
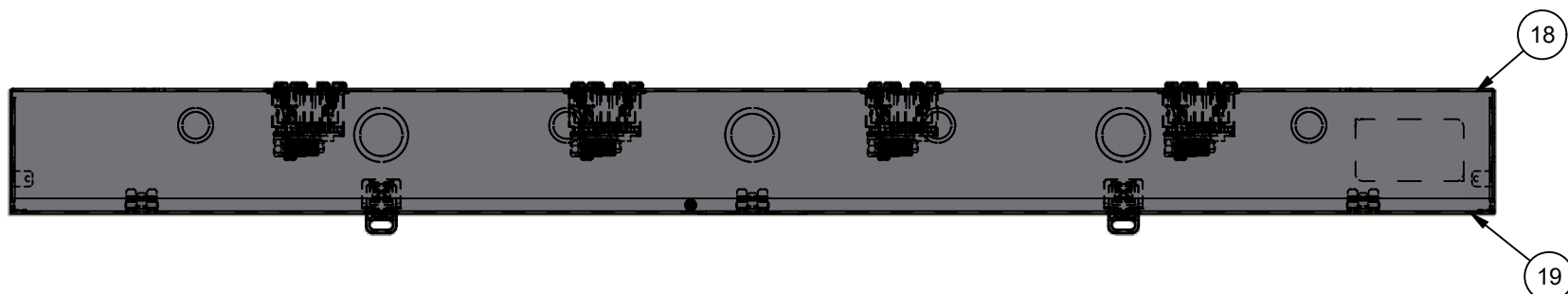
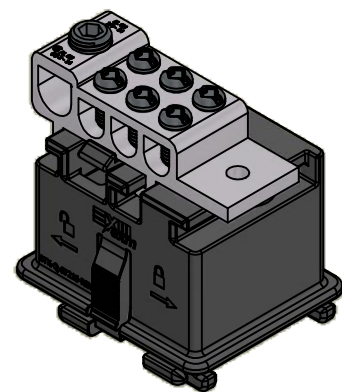

No.	Revisions	Date	By/Par
1	Redraw Model	11/08/2008	MichelP
2	Change Qty. tab on 400 & 600 AMP	08/12/2008	MichelP
3	Change for new hinge & change K-O size on 200 AMP	19/10/2009	MichelP
4	Turn into iLogic	20/4/2010	MichelP
5	Change sticker position and ground shape from 1.250 to 0.500	30/08/2010	AllenL

 Tél: (450) 979-4373
 Fax: (450) 979-4626
www.exmweb.com

Flatness Aplatissement: Max 3.0mm
 Projection: 

Customer Client	Date
Drawn By / Dessiné Par: BoxCad: Michelp	Date Aug./3/2010

Item	Qty	Part Number	Rev.	Description	MATERIAL	Color	Finish
19	1	1100T410C-P	5	1100T410 Cover Part	16 Ga H.R.P. & O. (1.4mm)	Asa-61 Grey	Smooth
18	1	1100T4104B-P	5	1100T4104 Body Part	16 Ga H.R.P. & O. (1.4mm)	Asa-61 Grey	Smooth
14	4	STK-A-55100	0	ST125 - Splitter Block and Lug	See Part List	See Part List	See Part List
7	1	STK-S-00250	0	Sticker 1100 B/T/BT Cover	Milar	Green Writing on White	N/A
6	2	STK-S-00100	0	3.5" x 2" Silver Milar Flexcon Sticker	Milar	Silver	N/A
5	1	STK-Q-05020	5	M5 x 8mm Thread Rolling Screw	Property Class 4.8 Steel	Bright	Zinc Plated
4	2	STK-Q-77450	3	Plastic Padlock Provision	Bayer FR110	Black	Fine Textured
3	3	STK-Q-33361	0	Spring Steel Hinge	0.75mm Spring Steel	Bright	Zinc Plated

Parts List

Material Matière: See Part List		Detail Rev.	
Color Couleur: See Part List	Finish Fini: See Part List	Description: 1100T Assembly	
Part Number Numéro Pièce: 1100T_MASTER		Rev. 5	1/3

This drawing is confidential and must not be reproduced or used without the consent of EXM

Ce dessin est confidentiel et ne doit pas être reproduit ou utilisé sans le consentement de EXM

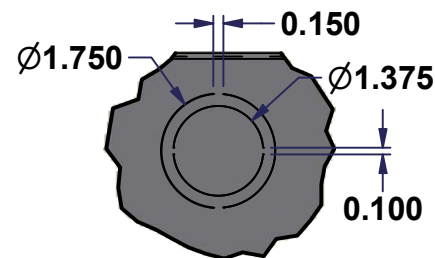

DETAIL C

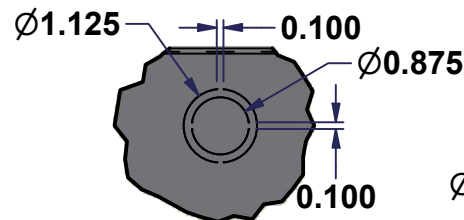

DETAIL D

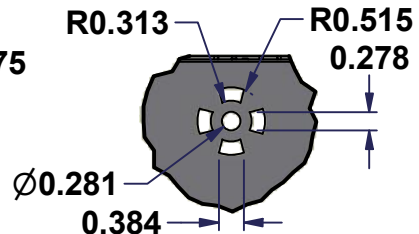

DETAIL E

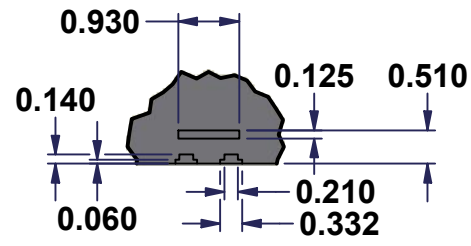

DETAIL F

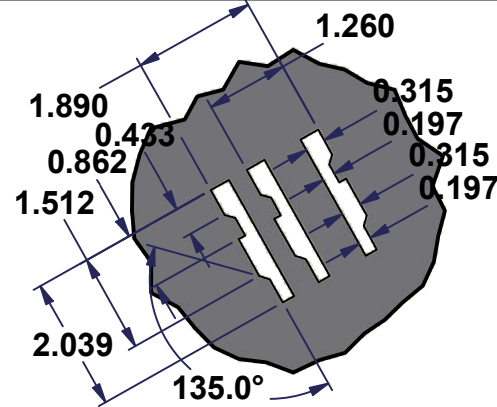

DETAIL G

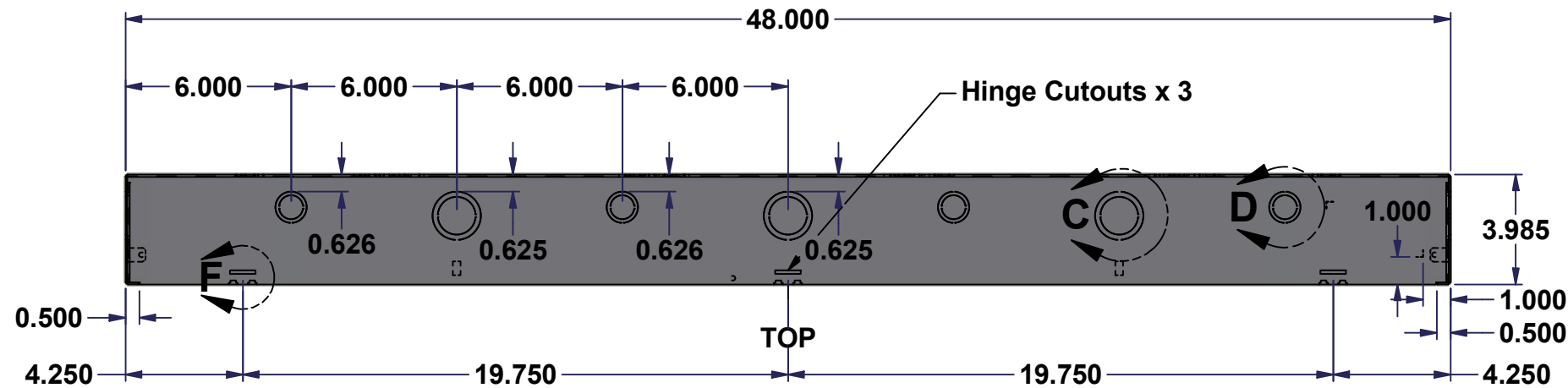

TOP

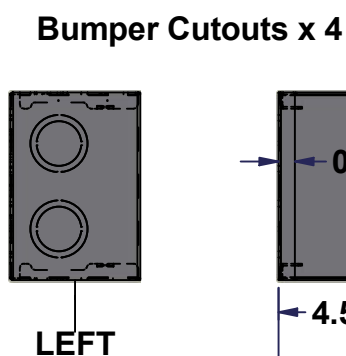

LEFT

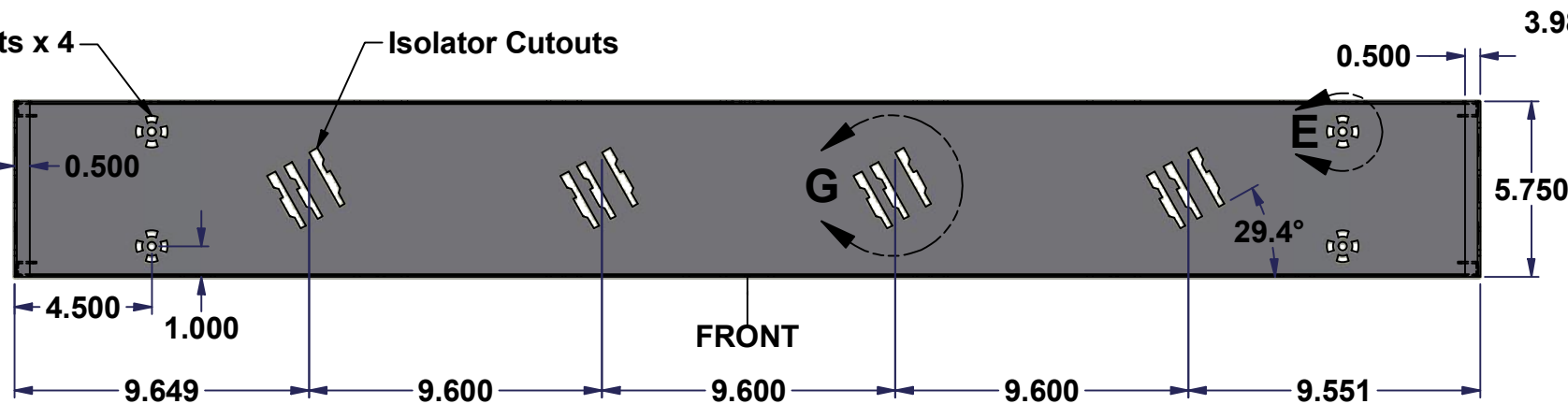

FRONT

RIGHT

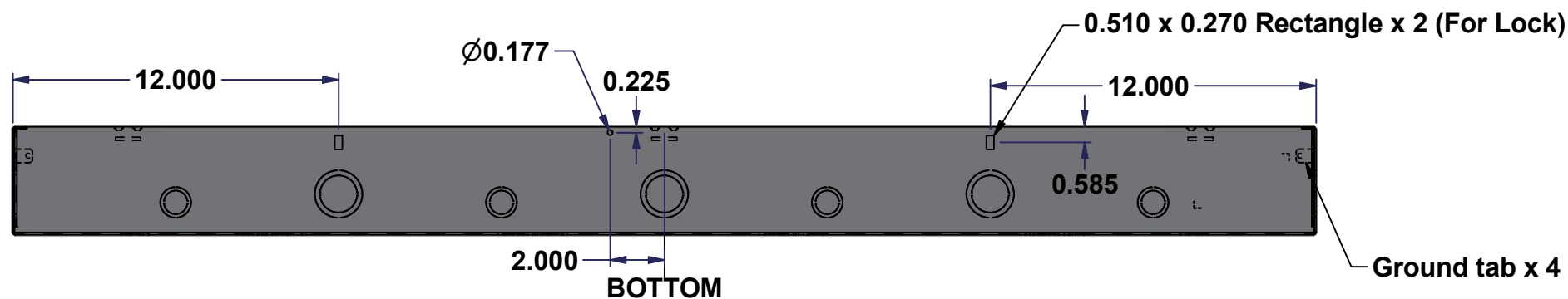

BOTTOM

Ground tab x 4

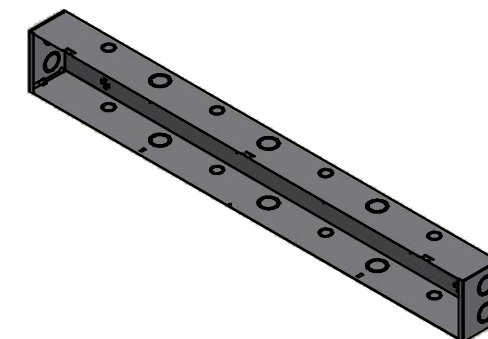

Isometric View



No.	Revisions	Date	By/Par
1	Redraw Model	11/08/2008	MichelP
2	Change Qty. tab on 400 & 600 AMP	08/12/2008	MichelP
3	Change for new hinge & change K-O size on 200 AMP	19/10/2009	MichelP
4	Turn into iLogic	21/04/2010	MichelP
5	Change sticker position and ground shape from 1.250 to 0.500	30/08/2010	AllenL

		Tél: (450) 979-4373 Fax: (450) 979-4626 www.exmweb.com	Flatness Aplatissement Max 3.0mm Projection
Customer Client	EXM Metal	Date	
Drawn By / Dessiné Par	BoxCad: Edgar Claros	Date Aug./3/2010	
Material Matière	16 Ga H.R.P. & O. (1.4mm)		
Color Couleur	Asa-61 Grey	Finish Fini	Smooth
Description		Detail Rev.	
1100T Body Part			
Part Number / Numéro Pièce	1100T_MASTER-BODY		Rev. 2
			3

ITEM	Qty	Part Number	Rev.	Description	MATERIAL	Color	Finish
1	1	1100T4104B-P	5	1100T4104 Body Part	16 Ga H.R.P. & O. (1.4mm)	Asa-61 Grey	Smooth

Parts List

This drawing is confidential and must not be reproduced or used without the consent of EXM

Ce dessin est confidentiel et ne doit pas être reproduit ou utilisé sans le consentement de EXM

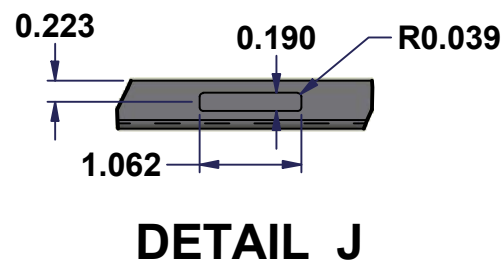
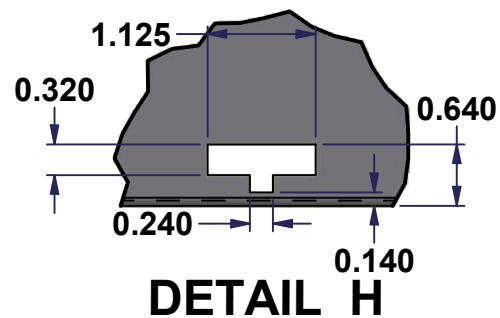
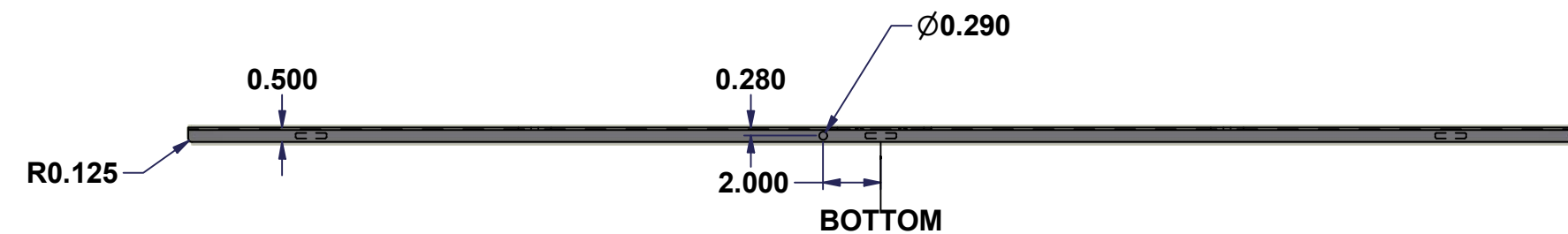
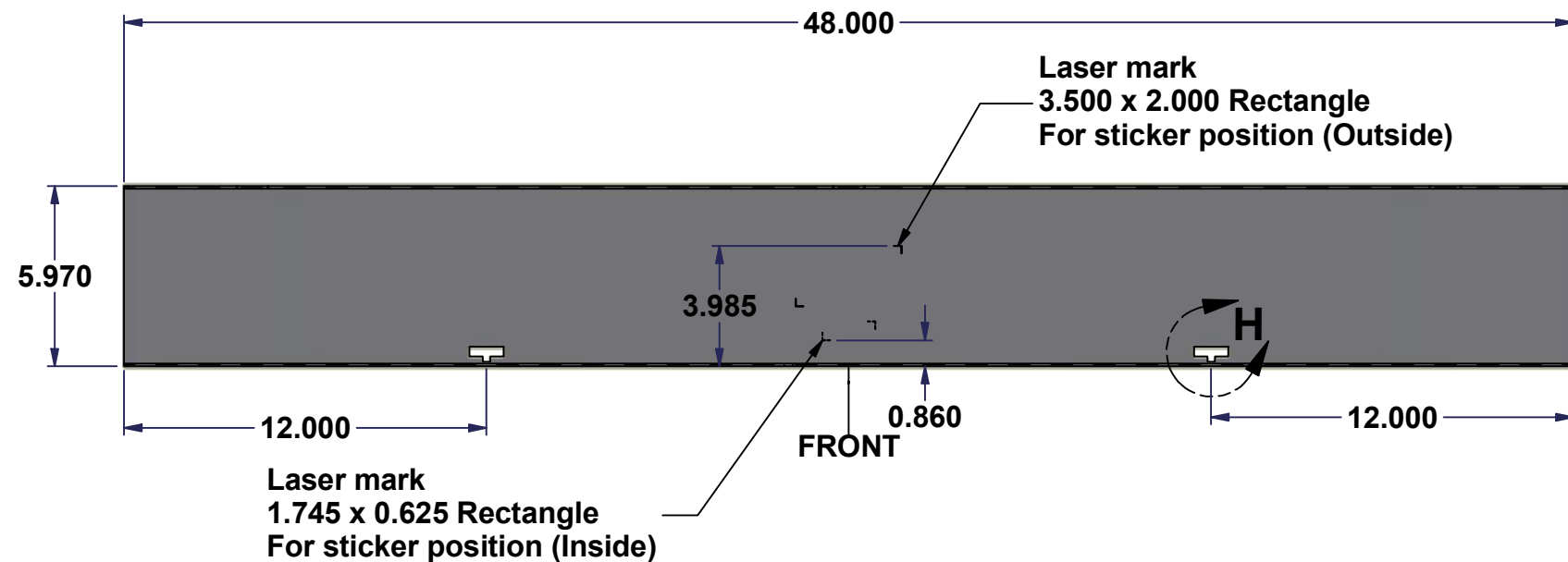
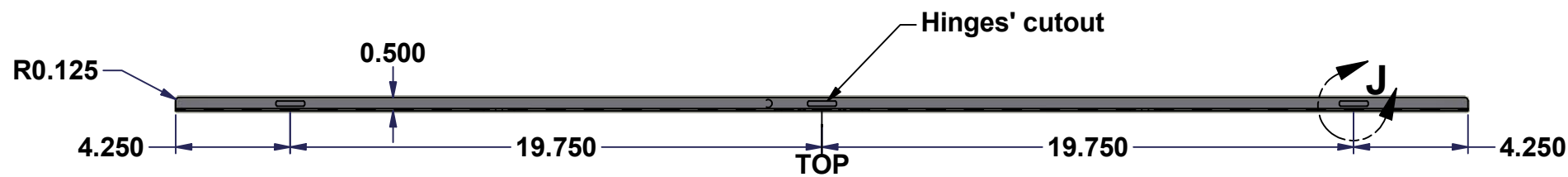

No.	Revisions	Date	By/Par
1	change Qty. tab on 400 & 600 AMP	11/08/2008	MichelP
2	change Qty. tab on 400 & 600 AMP	08/12/2008	MichelP
3	Change for new hinge & change K-O size on 200 AMP	19/10/2009	MichelP
4	Turn into iLogic	20/4/2010	MichelP
5	Change sticker position and ground shape from 1.250 to 0.500	30/08/2010	AllenL



Isometric View

Tél: (450) 979-4373 Fax: (450) 979-4626 www.exmweb.com		Flatness Aplatissement Max 3.0mm Projection
Customer Client	EXM Manufacturing	Date
Drawn By / Dessiné Par	BoxCad: Edgar Claros	Date Aug./3/2010
Material Matière	16 Ga H.R.P. & O. (1.4mm)	
Color Couleur	Asa-61 Grey	Finish Fini: Smooth
Description		Detail Rev.
1100T Cever Part		
Part Number / Numéro Pièce	1100T_MASTER-COVER	Rev. 3
		5

ITEM	Qty	Part Number	Rev.	Description	MATERIAL	Color	Finish
1	1	1100T410C-P	5	1100T410 Cover Part	16 Ga H.R.P. & O. (1.4mm)	Asa-61 Grey	Smooth

Parts List