

All knockouts are actual size / Les disques défonçables sont grandeur réel  
 All dimensions are before paint / Toutes les dimensions sont avant peinture

This drawing is confidential and must not be reproduced or used without the consent of EXM

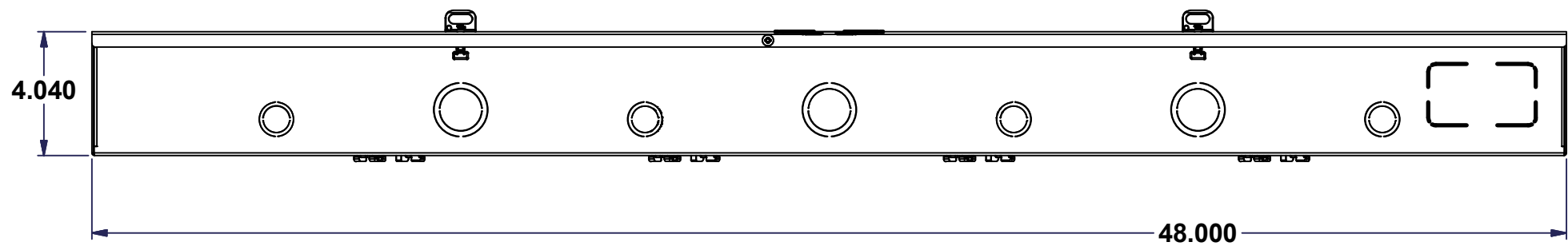

No.	Revisions	Date	By/Par
1	Redraw Model	11/08/2008	MichelP
2	Change Qty. tab on 400 & 600 AMP	08/12/2008	MichelP
3	Change for new hinge & change K-O size on 200 AMP	19/10/2009	MichelP
4	Turn into iLogic	20/4/2010	MichelP
5	Change sticker position and ground shape from 1.250 to 0.500	30/08/2010	AllenL

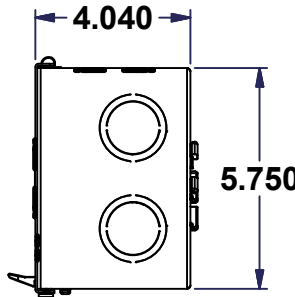
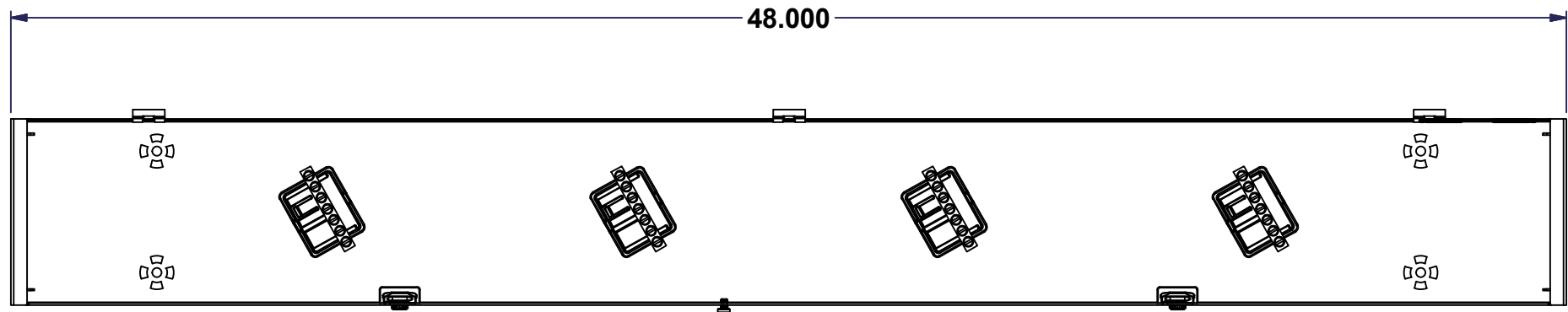
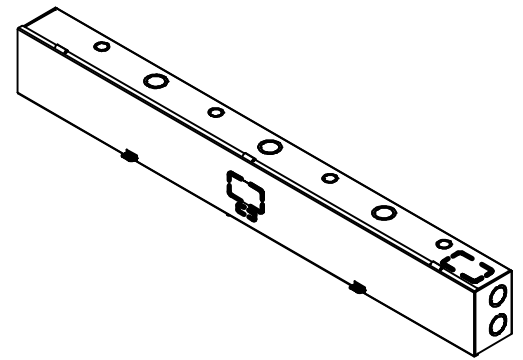

Isometric View

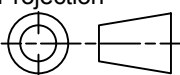

Ce dessin est confidentiel et ne doit pas être reproduit ou utilisé sans le consentement de EXM

 Tél: (450) 979-4373 Fax: (450) 979-4626 <a href="http://www.exmweb.com">www.exmweb.com</a>		Flatness Aplatissement Max 3.0mm Projection 
Customer Client	Date	
Drawn By Dessiné Par MichaelA	Date 10-Feb-15	
Material Matière	See Part List	
Color Couleur	See Part List	Finish Fini See Part List
Description 1100 T474 Assembly		Detail Rev.
Part Number Numéro Pièce <b>1100T474</b>	Rev. <b>5</b>	1 3

All knockouts are actual size / Les disques défonçables sont grandeur réel  
 All dimensions are before paint / Toutes les dimensions sont avant peinture

No.	Revisions	Date	By/Par
1	Redraw Model	11/08/2008	MichelP
2	Change Qty. tab on 400 & 600 AMP	08/12/2008	MichelP
3	Change for new hinge & change K-O size on 200 AMP	19/10/2009	MichelP
4	Turn into iLogic	20/4/2010	MichelP
5	Change sticker position and ground shape from 1.250 to 0.500	30/08/2010	AllenL

This drawing is confidential and must not be reproduced or used without the consent of EXM

Ce dessin est confidentiel et ne doit pas être reproduit ou utilisé sans le consentement de EXM

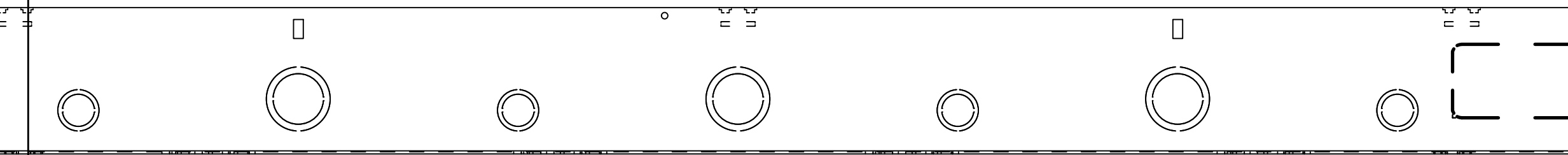
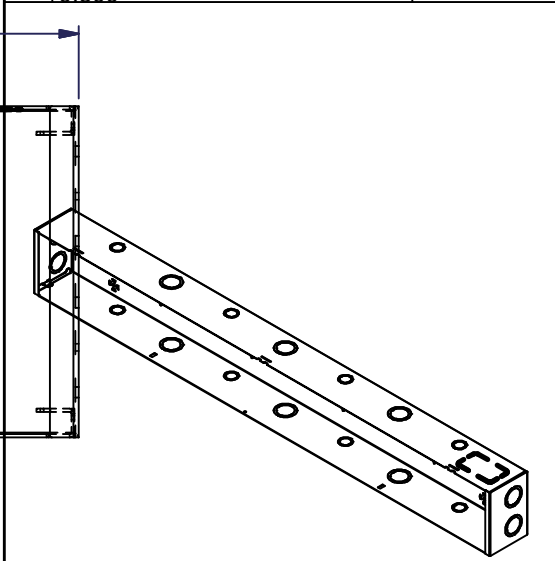
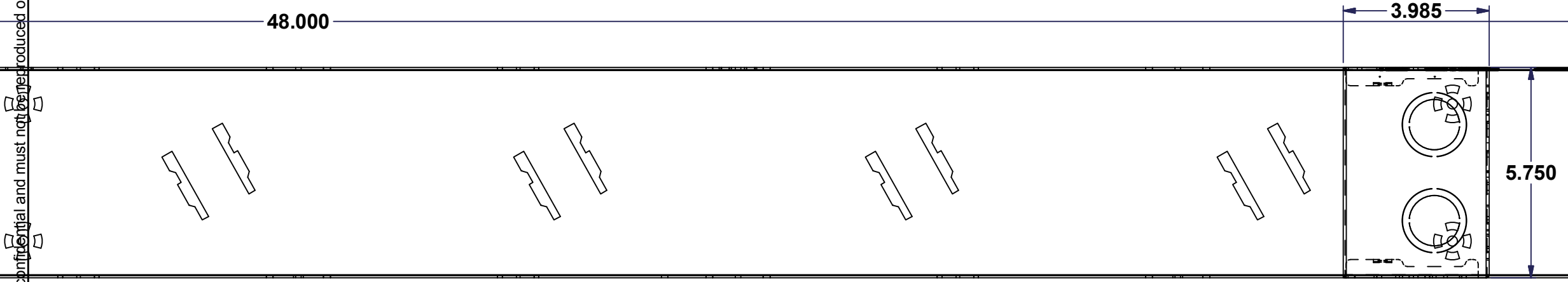

Isometric View

48.000

**EXM**  
 exm  
 Tél: (450) 979-4373  
 Fax: (450) 979-4626  
[www.exmweb.com](http://www.exmweb.com)

Flatness  
 Aplatissement  
 Max 3.0mm  
 Projection

Customer Client	Date
Drawn By / Dessiné Par: MichaelA	Date: 10-Feb-15
Material / Matière	See Part List
Color / Couleur	See Part List
Finish / Fini	See Part List
Description	Detail Rev.
1100 T474 body	
Part Number / Numéro Pièce: <b>1100T474B</b>	Rev. 5
	2 / 3

All knockouts are actual size / Les disques défonçables sont grandeur réel  
 All dimensions are before paint / Toutes les dimensions sont avant peinture

This drawing is confidential and must not be reproduced or used without the consent of EXM

Ce dessin est confidentiel et ne doit pas être reproduit ou utilisé sans le consentement de EXM

No.	Revisions	Date	By/Par
1	Redraw Model	11/08/2008	MichelP
2	Change Qty. tab on 400 & 600 AMP	08/12/2008	MichelP
3	change for new hinge & change K-O size on 200 AMP	19/10/2009	MichelP
4	Turn into iLogic	20/4/2010	MichelP
5	Change sticker position and ground shape from 1.250 to 0.500	30/08/2010	AllenL

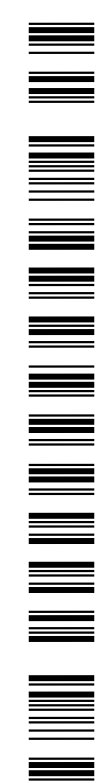
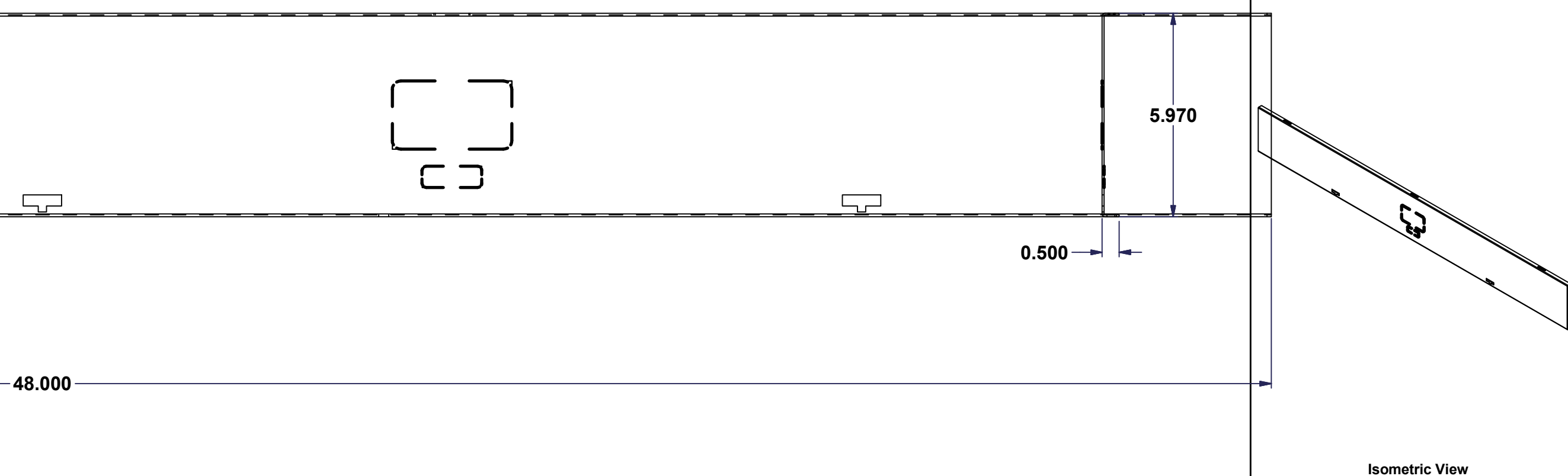

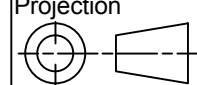
 Tél: (450) 979-4373 Fax: (450) 979-4626 <a href="http://www.exmweb.com">www.exmweb.com</a>		Flatness Aplatissement Max 3.0mm
Projection 		
Customer Client	Date	
Drawn By / Dessiné Par: MichaelA	Date: 10-Feb-15	
Material / Matière	See Part List	
Color / Couleur: See Part List	Finish / Fini	See Part List
Description: 1100 T47 Cover	Detail Rev.	
Part Number / Numéro Pièce: <b>1100T47C</b>	Rev. <b>5</b>	3