

This drawing is confidential and must not be reproduced or used without the consent of EXM

Ce dessin est confidentiel et ne doit pas être reproduit ou utilisé sans le consentement de EXM

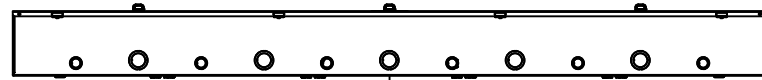

TOP



BACK

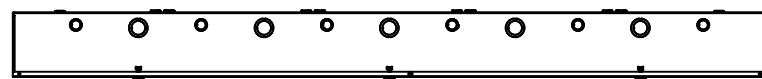

BOTTOM

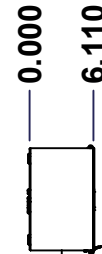

LEFT

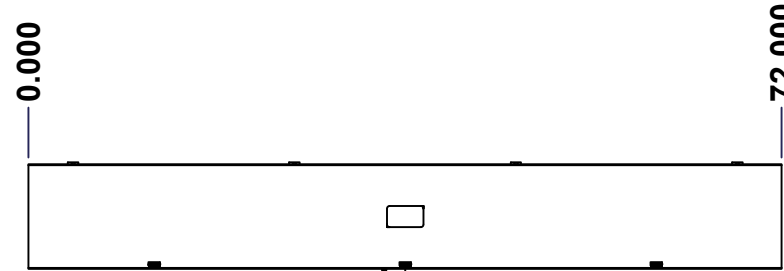

FRONT

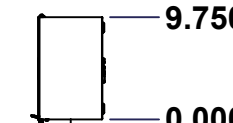

RIGHT

No.	Revisions	Date	By/Par

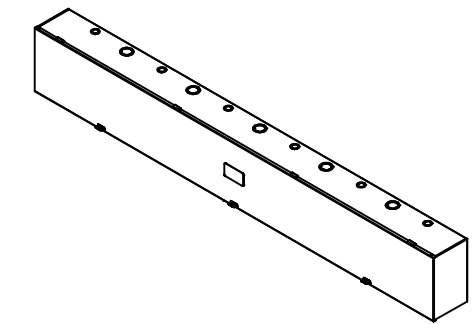

Isometric View



Tél: (450) 979-4373
 Fax: (450) 979-4626
www.exmweb.com

Flatness
Aplatissement

Max 3.0mm

Projection

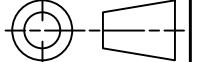

Customer Client	Date
Drawn By / Dessiné Par: BoxCad: BoxCad	Date: 19-Dec-23

Material / Matière: 16 Ga Cold Rolled A1008 CS Type B (1.4mm)

Color / Couleur: Asa-61 Grey	Finish / Fini: Smooth
------------------------------	-----------------------

Description: 1100T 9.75" x 72" x 6.11" Assembly

Part Number / Numéro Pièce: 1100T6404	Rev. 0	1 / 8
---------------------------------------	--------	-------

SEE BILL OF MATERIAL ON LAST PAGE

This drawing is confidential and must not be reproduced or used without the consent of EXM

Ce dessin est confidentiel et ne doit pas être reproduit ou utilisé sans le consentement de EXM

NOTE	
ITEM	DESCRIPTION
1	NEMA 1 Enclosure (IP20)
2	C/W Standard ground studs on box and cover
3	W/O Inner panel
4	W/O Inner panel mounting studs

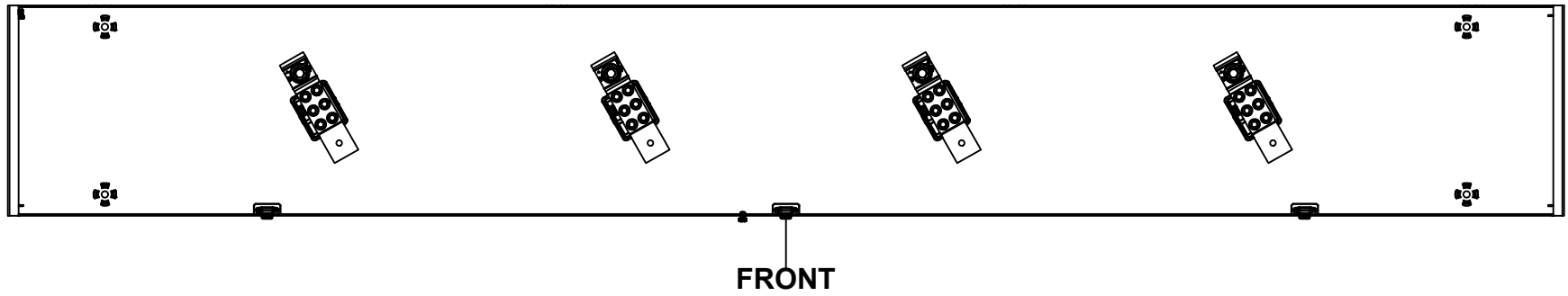

No.	Revisions	Date	By/Par

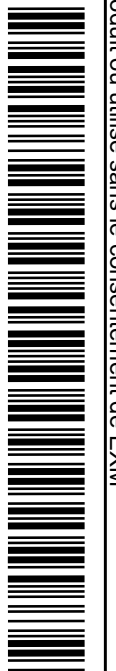
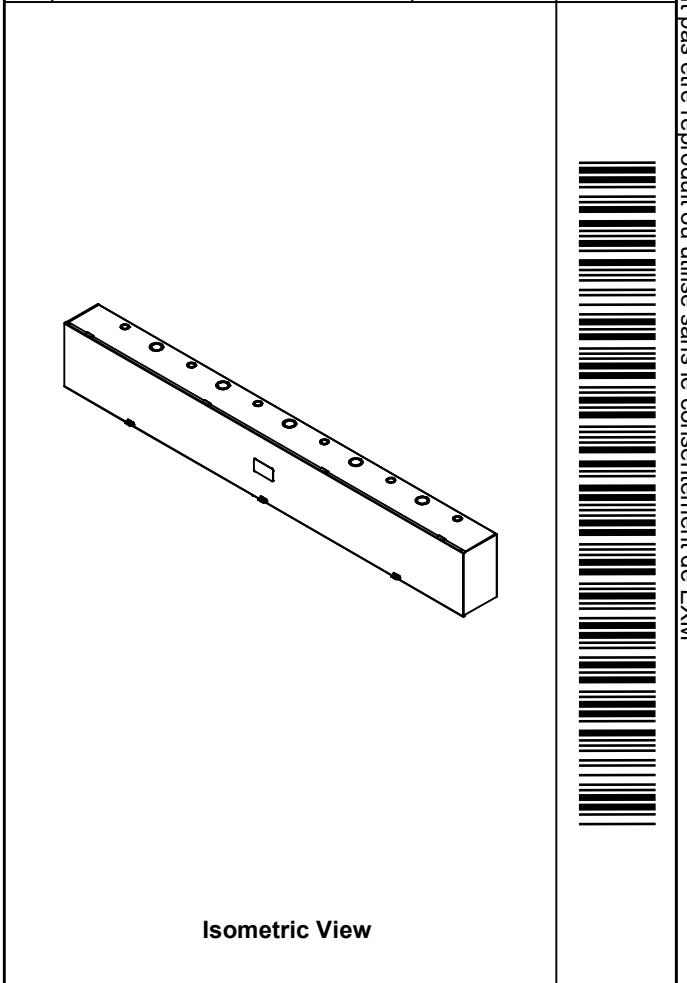

PACKING		
ITEM	QTY	DESCRIPTION
Cardboard sleeve	2	Top and Bottom
Cardboard strip	2	Between back of enclosure and inner panel
Plastic bag	1	To protect cover surface and inside gasket
Cardboard corner	4	To reinforced for the plastic strap tightening
Plastic strap - Black	2	To Squeeze the 2 cardboard sleeve together
Packaging label	3	White label with PN
Plastic strap- Green	2	To secure the enclosure to the wood pallet
Wood Pallet	1	2" deeper and 3" larger than enclosure size

Qty	Part Number	Rev	Description
3	STK-Q-77450	3	Plastic Padlock Provision
1	1100T6404C	0	1100T 18" x 72" Cover
1	STK-K-02700	0	1412 T Accessory Kit
1	1100T6404B	0	1100T 9.75" x 72" x 6.11" Body
4	881 BRC400	6	Accessory kit for 1100T (lug 400AMP)

Parts List

Tél: (450) 979-4373
Fax: (450) 979-4626
www.exmweb.com

Flatness
Aplatissement
Max 3.0mm

Projection

Customer Client	Date
Drawn By Dessiné Par BoxCad: BoxCad	Date 19-Dec-23
Material Matière 16 Ga Cold Rolled A1008 CS Type B (1.4mm)	
Color Couleur Asa-61 Grey	Finish Fini Smooth
Description 1100T 9.75" x 72" x 6.11" Assembly	Detail Rev.
Part Number Numéro Pièce 1100T6404	Rev. 0 / 2

This drawing is confidential and must not be reproduced or used without the consent of EXM

Ce dessin est confidentiel et ne doit pas être reproduit ou utilisé sans le consentement de EXM

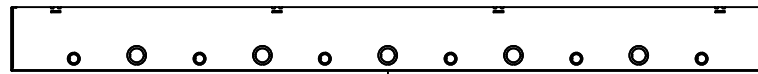

TOP

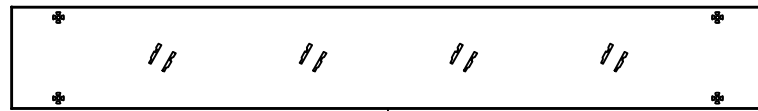

BACK

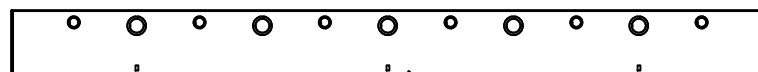

BOTTOM

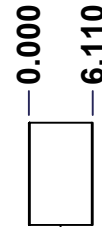

LEFT

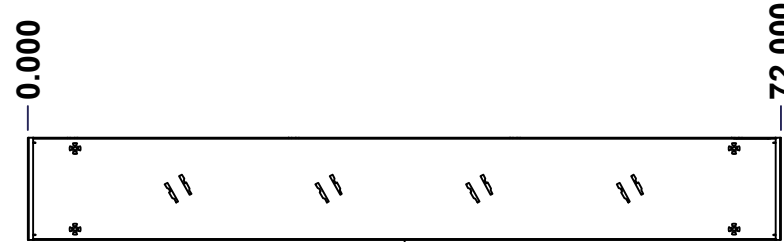

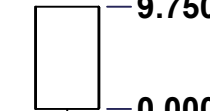

FRONT

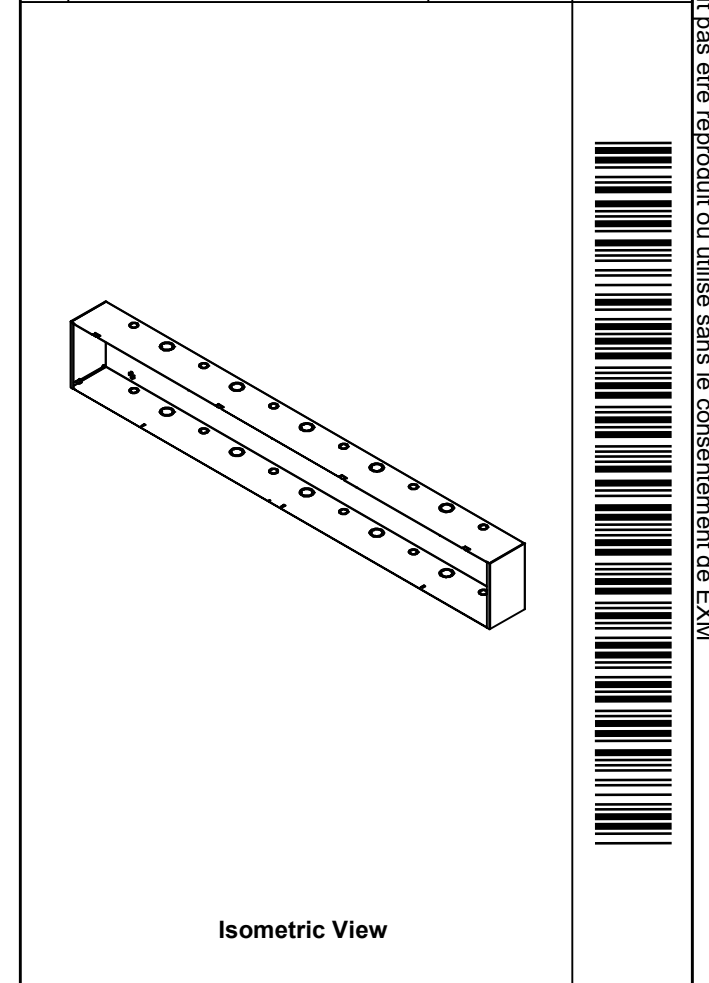

RIGHT

No.	Revisions	Date	By/Par

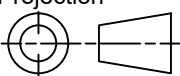

 Tél: (450) 979-4373 Fax: (450) 979-4626 www.exmweb.com		Flatness Aplatissement Max 3.0mm Projection 
Customer Client	Date	
Drawn By Dessiné Par	BoxCad: BoxCad	Date 19-Dec-23
Material Matière	16 Ga Cold Rolled A1008 CS Type B (1.4mm)	
Color Couleur	Asa-61 Grey	Finish Fini Smooth
Description	Detail Rev.	
1100T 9.75" x 72" x 6.11" Body		
Part Number Numéro Pièce	Rev. 0	3/8

SEE BILL OF MATERIAL ON LAST PAGE

1100T6404B

This drawing is confidential and must not be reproduced or used without the consent of EXM

Ce dessin est confidentiel et ne doit pas être reproduit ou utilisé sans le consentement de EXM

STANDARD FEATURES ARE NOT LISTED IN THIS HOLE TABLE

HOLE TABLE - TOP VIEW (CUSTOM FEATURE ONLY)

CUT-OUT	XDIM	YDIM	DESCRIPTION
1	24.000	1.500	DKO Ø1.750 - 1.375
2	18.000	1.188	DKO Ø1.125 - 0.875
3	12.000	1.500	DKO Ø1.750 - 1.375
4	6.000	1.188	DKO Ø1.125 - 0.875
5	66.000	1.188	DKO Ø1.125 - 0.875
6	60.000	1.500	DKO Ø1.750 - 1.375
7	54.000	1.188	DKO Ø1.125 - 0.875
8	48.000	1.500	DKO Ø1.750 - 1.375
9	42.000	1.188	DKO Ø1.125 - 0.875
10	36.000	1.500	DKO Ø1.750 - 1.375
11	30.000	1.188	DKO Ø1.125 - 0.875

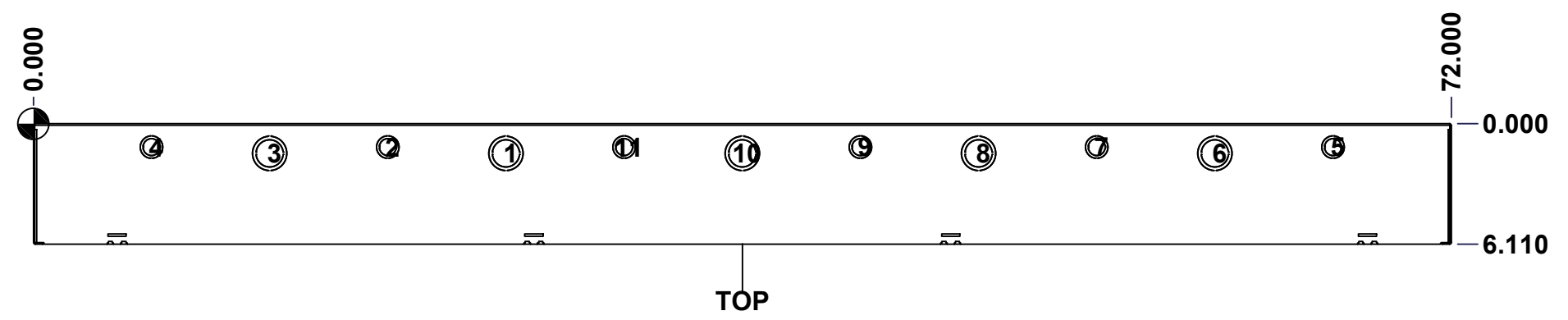

	Description	Status	
	1100T 9.75" x 72" x 6.11" Body	(NULL)	
	Part Number Numéro Pièce	Rev.	
	1100T6404B	0	4 8

This drawing is confidential and must not be reproduced or used without the consent of EXM

Ce dessin est confidentiel et ne doit pas être reproduit ou utilisé sans le consentement de EXM

STANDARD FEATURES ARE NOT LISTED IN THIS HOLE TABLE

HOLE TABLE - BOTTOM VIEW (CUSTOM FEATURE ONLY)

CUT-OUT	XDIM	YDIM	DESCRIPTION
1	18.000	1.188	DKO Ø1.125 - 0.875
2	12.000	1.500	DKO Ø1.750 - 1.375
3	6.000	1.188	DKO Ø1.125 - 0.875
4	66.000	1.188	DKO Ø1.125 - 0.875
5	60.000	1.500	DKO Ø1.750 - 1.375
6	54.000	1.188	DKO Ø1.125 - 0.875
7	48.000	1.500	DKO Ø1.750 - 1.375
8	42.000	1.188	DKO Ø1.125 - 0.875
9	36.000	1.500	DKO Ø1.750 - 1.375
10	30.000	1.188	DKO Ø1.125 - 0.875
11	24.000	1.500	DKO Ø1.750 - 1.375

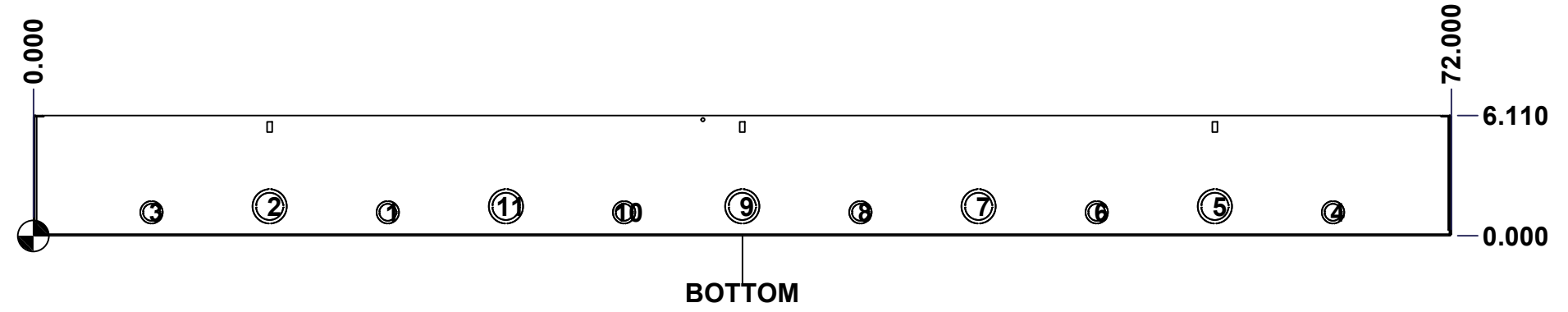

	Description	Status	
	1100T 9.75" x 72" x 6.11" Body	(NULL)	
	Part Number Numéro Pièce	Rev.	
	1100T6404B	0	5 8

This drawing is confidential and must not be reproduced or used without the consent of EXM

Ce dessin est confidentiel et ne doit pas être reproduit ou utilisé sans le consentement de EXM

No.	Revisions	Date	By/Par

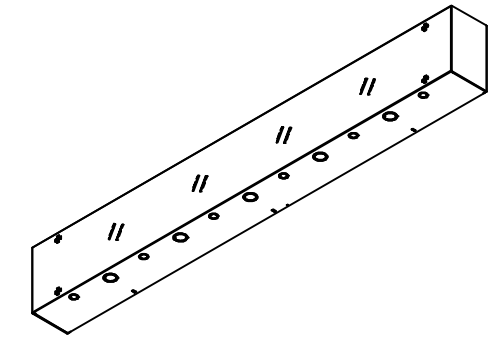

Isometric View

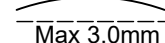

 Tél: (450) 979-4373 Fax: (450) 979-4626 www.exmweb.com		Flatness Aplatissement  Max 3.0mm
Customer Client		Date
Drawn By / Dessiné Par: BoxCad: BoxCad		Date: 19-Dec-23
Material / Matière: 16 Ga Cold Rolled A1008 CS Type B (1.4mm)		
Color / Couleur: Asa-61 Grey	Finish / Fini: Smooth	
Description: 1100T 9.75" x 72" x 6.11" Body		Detail Rev.
Part Number / Numéro Pièce: 1100T6404B		Rev. 6 / 8

Qty	Part Number	Rev	Description
1	STK-P-02400S	0	Powder Paint (Asa-61 Grey / Smooth)
1	STK-S-00100	0	3.5" x 2" Silver Milar Flexcon Sticker
1	1100T6404B-P	0	1100T 9.75" x 72" x 6.11" Body Part
Parts List			

This drawing is confidential and must not be reproduced or used without the consent of EXM

Ce dessin est confidentiel et ne doit pas être reproduit ou utilisé sans le consentement de EXM

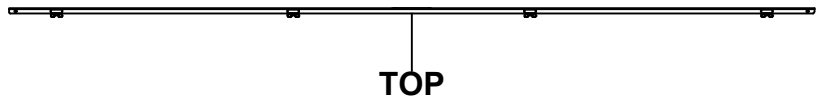

TOP

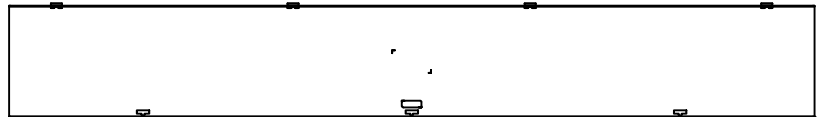

BACK

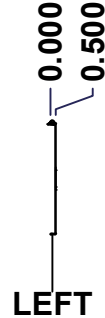

LEFT

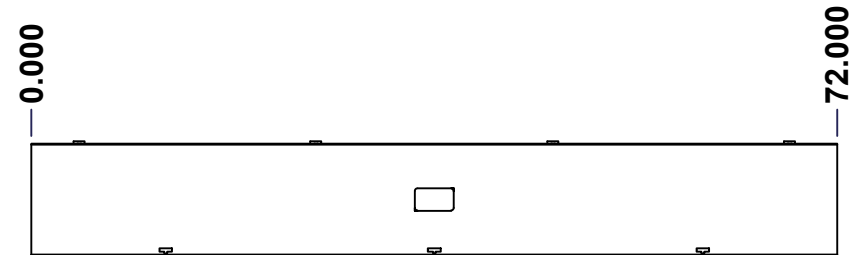

FRONT

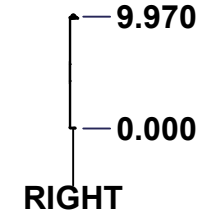

RIGHT



BOTTOM

No.	Revisions	Date	By/Par

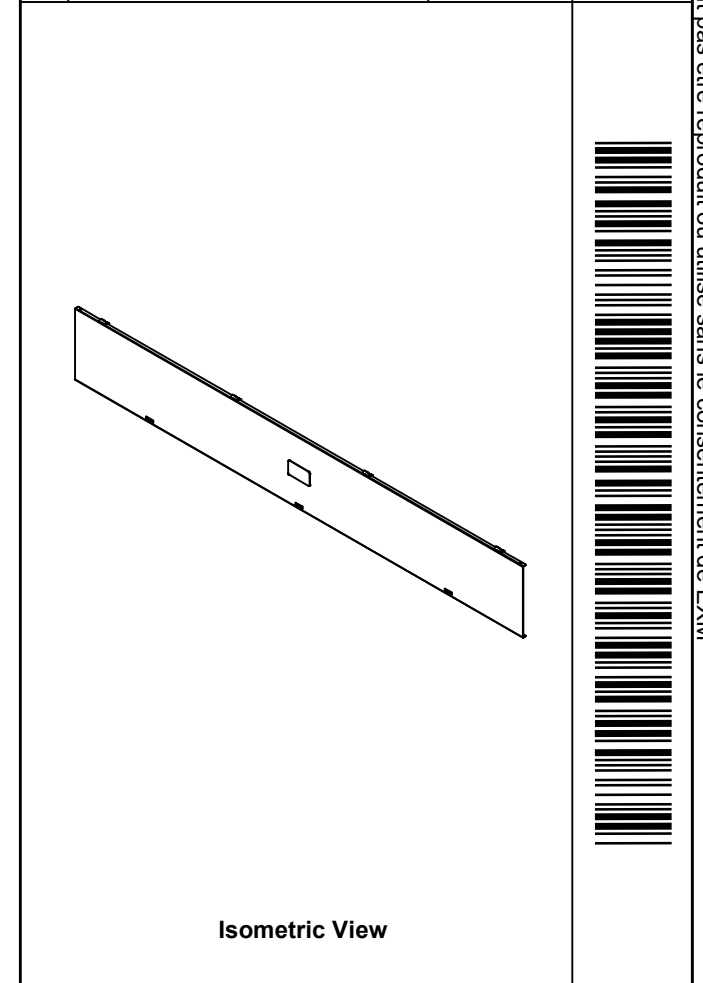

Isometric View

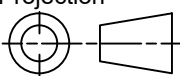

 Tél: (450) 979-4373 Fax: (450) 979-4626 www.exmweb.com		Flatness Aplatissement Max 3.0mm Projection 
Customer Client	Date	
Drawn By Dessiné Par	BoxCad: BoxCad	Date 19-Dec-23
Material Matière	16 Ga Cold Rolled A1008 CS Type B (1.4mm)	
Color Couleur	Asa-61 Grey	Finish Fini Smooth
Description 1100T 18" x 72" Cover		Detail Rev.
Part Number Numéro Pièce	1100T6404C	Rev. 7 0 8

SEE BILL OF MATERIAL ON LAST PAGE

This drawing is confidential and must not be reproduced or used without the consent of EXM

Ce dessin est confidentiel et ne doit pas être reproduit ou utilisé sans le consentement de EXM

No.	Revisions	Date	By/Par

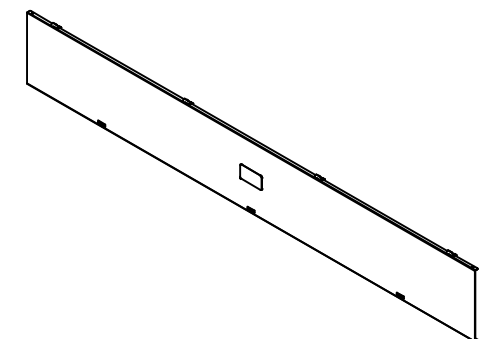

Isometric View



Tél: (450) 979-4373
 Fax: (450) 979-4626
www.exmweb.com

Flatness
Aplatissement
Max 3.0mm
Projection

Customer Client	Date
Drawn By / Dessiné Par: BoxCad: BoxCad	Date: 19-Dec-23
Material / Matière: 16 Ga Cold Rolled A1008 CS Type B (1.4mm)	

Color / Couleur: Asa-61 Grey	Finish / Fini: Smooth
------------------------------	-----------------------

Description: 1100T 18" x 72" Cover	Detail Rev.
------------------------------------	-------------

Part Number / Numéro Pièce: 1100T6404C	Rev. 0	8
---	--------	---

QTY	Part Number	Rev	Description
1	STK-P-02400S	0	Powder Paint (Asa-61 Grey / Smooth)
1	STK-S-00250	0	15.8mm x 44.45mm Silver Milar Sticker
1	STK-S-00100	0	3.5" x 2" Silver Milar Flexcon Sticker
4	STK-Q-33361	0	Spring Steel Hinge
1	1100T6404C-P	0	1100T 9.75" x 72" x 0" Cover Part
Parts List			