

All knockouts are actual size / Les disques défonçables sont grandeur réel
 All dimensions are before paint / Toutes les dimensions sont avant peinture

This drawing is confidential and must not be reproduced or used without the consent of EXM

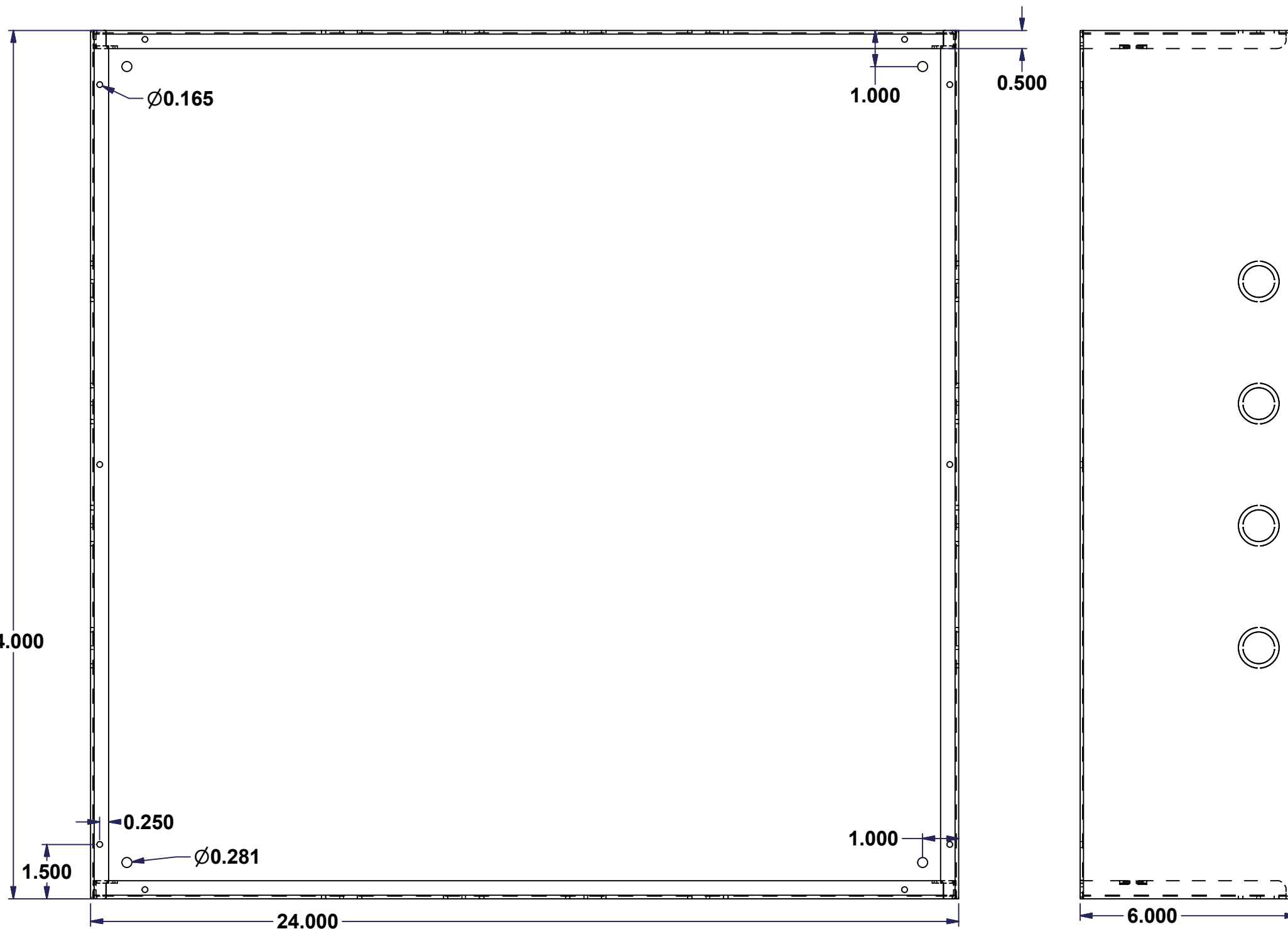

| No. | Revisions | Date | By/Par |
|-----|-----------------------------------|------------|--------|
| 1 | Turn into iLogic | 12/27/2010 | AllenL |
| 1.1 | Add lacer cut on grounding flange | 20/01/2011 | AllenL |
| | | | |
| | | | |

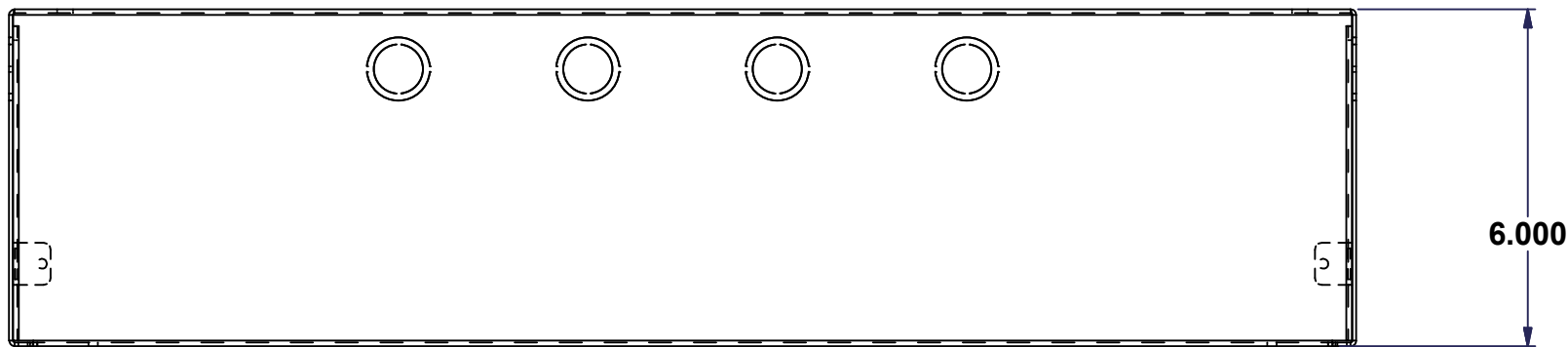
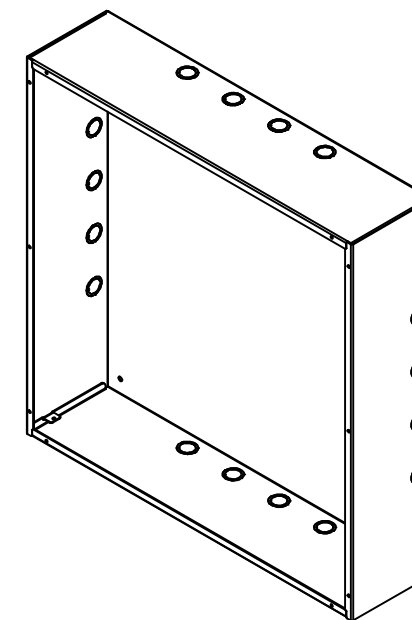

Isometric View

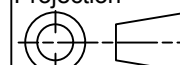

Ce dessin est confidentiel et ne doit pas être reproduit ou utilisé sans le consentement de EXM

| | | |
|--|----------------|---|
|  Tél: (450) 979-4373 Fax: (450) 979-4626 www.exmweb.com | | Flatness Aplatissement Max 3.0mm Projection  |
| Customer Client | Date | |
| Drawn By Dessiné Par MichaelA | Date 10-Feb-15 | |
| Material Matière | See Part List | |
| Color Couleur | See Part List | Finish Fini See Part List |
| Description 1100 TC 24" x 24" x 6" Assembly | | Detail Rev. |
| Part Number Numéro Pièce 1100TC242406 | Rev. 1 | 1/1 |