

This drawing is confidential and must not be reproduced or used without the consent of EXM

All knockouts are actual size / Les disques défonçables sont grandeur réel
 All dimensions are before paint / Toutes les dimensions sont avant peinture

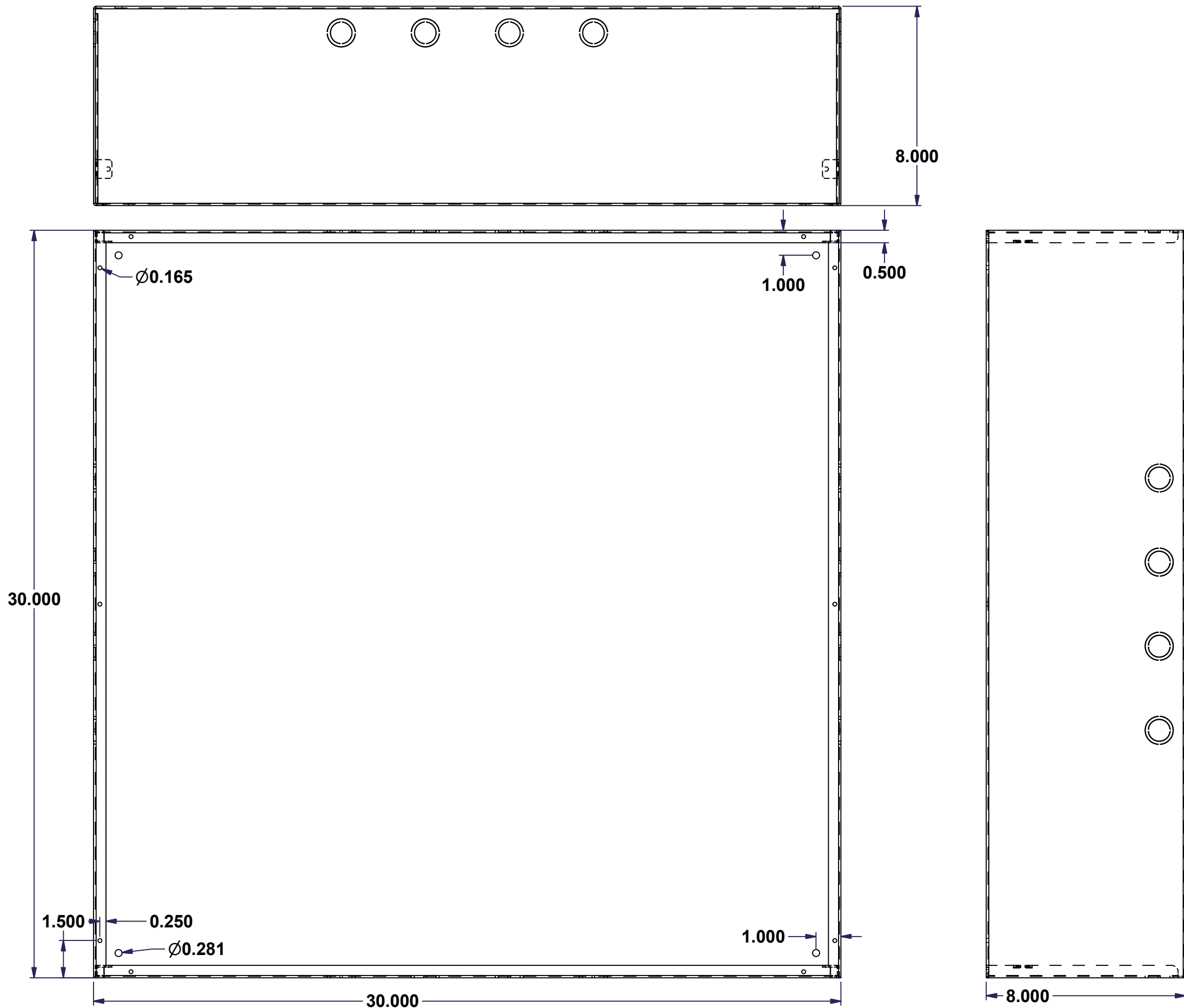

No.	Revisions	Date	By/Par
1	Turn into iLogic	12/27/2010	AllenL
1.1	Add lacer cut on grounding flange	20/01/2011	AllenL

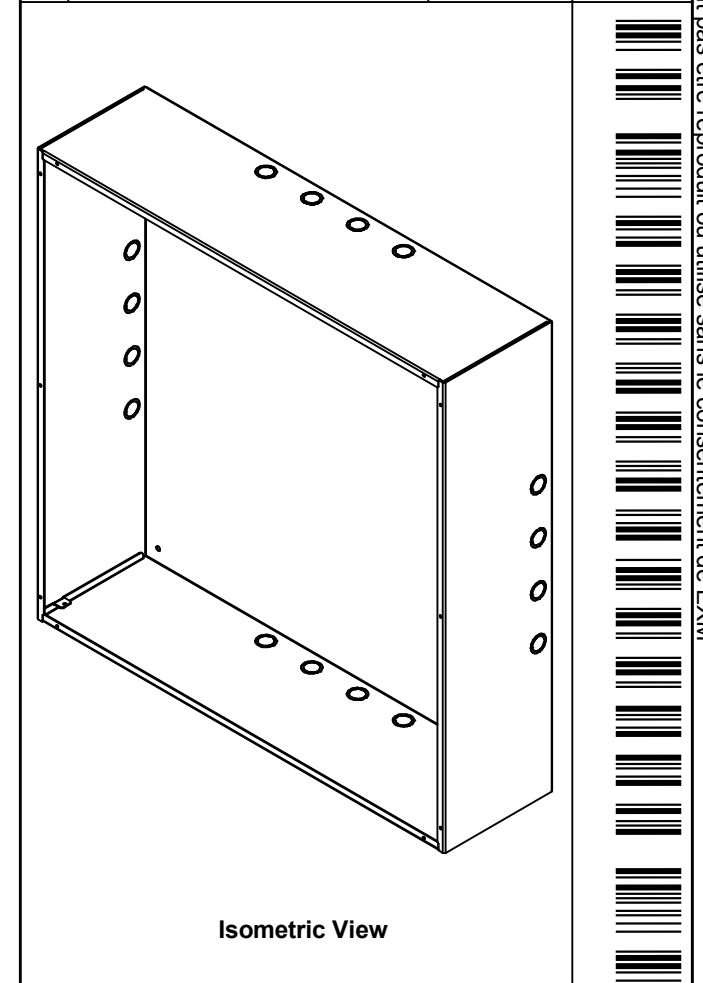

Ce dessin est confidentiel et ne doit pas être reproduit ou utilisé sans le consentement de EXM

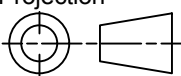
 Tél: (450) 979-4373 Fax: (450) 979-4626 www.exmweb.com		Flatness Aplatissement Max 3.0mm Projection 
Customer Client	Date	
Drawn By / Dessiné Par: MichaelA	Date: 10-Feb-15	
Material / Matière	See Part List	
Color / Couleur: See Part List	Finish / Fini: See Part List	
Description: 1100 TC 30" x 30" x 8" Assembly		Detail Rev.
Part Number / Numéro Pièce: 1100TC303008	Rev. 1	1