

This drawing is confidential and must not be reproduced or used without the consent of EXM

All knockouts are actual size / Les disques défonçables sont grandeur réel
 All dimensions are before paint / Toutes les dimensions sont avant peinture

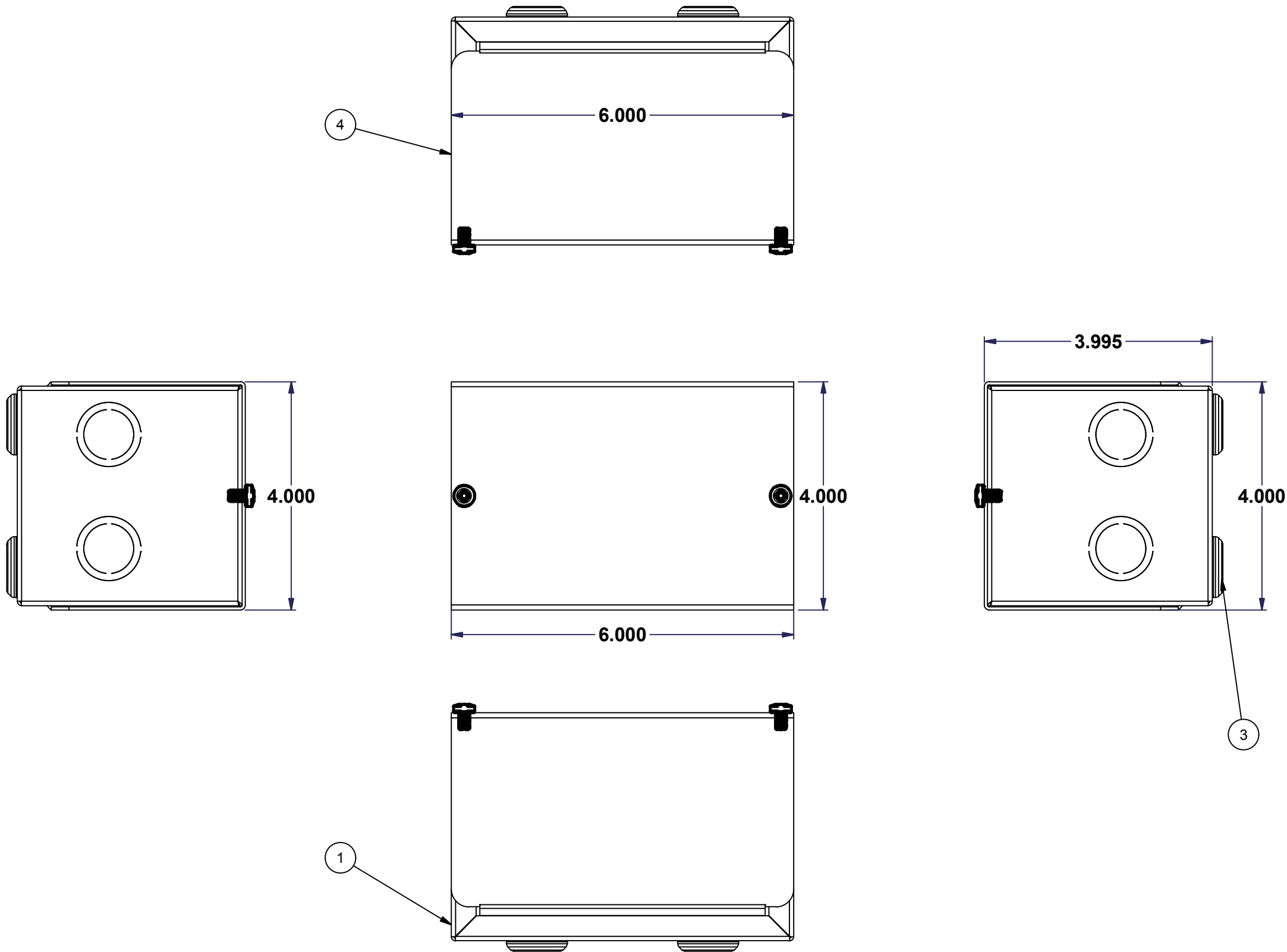

No.	Revisions	Date	By/Par
1	Update Model	02-Oct-08	MichelP
2	Turn into iLogic	7/7/2010	AllenL
2.1.0	Change all Material to 18Ga Cold Rolled Steel except vented cover	8/18/2010	AllenL

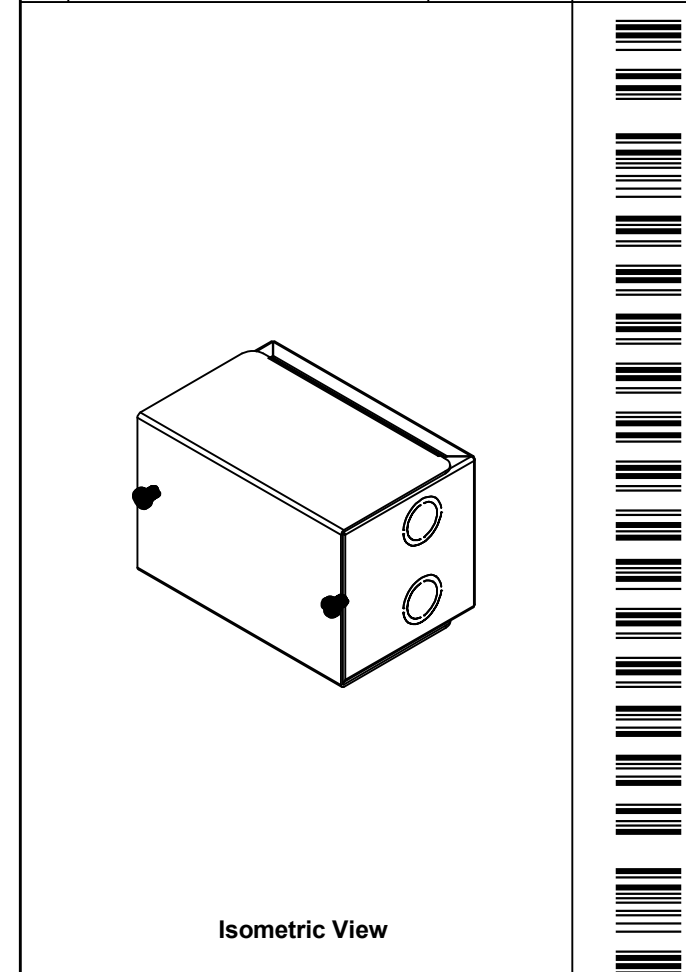

EXM
 Tél: (450) 979-4373
 Fax: (450) 979-4626
www.exmweb.com

Flatness
 Aplatissement
 Max 3.0mm

Projection

Customer Client	Date
Drawn By / Dessiné Par: MichaelA	Date: 23-Mar-15

Material / Matière: See Part List

Color / Couleur: See Part List Finish / Fini: See Part List

Parts List							
Item	Qty	Part Number	Rev	Description	Material	Color	Finish
1	1	1100VE060404B-P	2	1100VE 6" x 4" x 4" Ventilated Enclosure Body Part		See Part List	See Part List
2	1	STK-K-01810	0	1100VE Accessory Kit		See Part List	See Part List
3	4	STK-Q-67600	1	Bumper	Rubber	BLACK	N/A
4	1	1100VE060404C-P	2	1100VE 6" x 4" x 4" Ventilated Enclosure Cover Part		See Part List	See Part List

Description: 1100VE 6" x 4" x 4" Ventilated Enclosure Assembly	Detail Rev.
Part Number / Numéro Pièce: 1100VE060404	Rev. 2

Ce dessin est confidentiel et ne doit pas être reproduit ou utilisé sans le consentement de EXM