

This drawing is confidential and must not be reproduced or used without the consent of EXM

Ce dessin est confidentiel et ne doit pas être reproduit ou utilisé sans le consentement de EXM



TOP



BACK

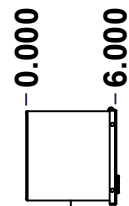

LEFT

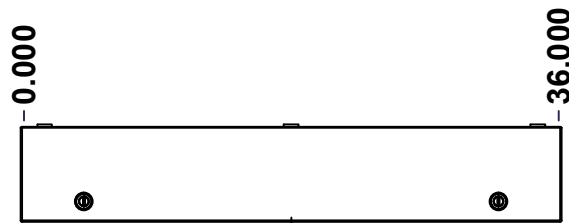

FRONT

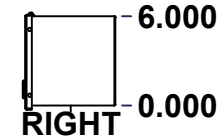

RIGHT

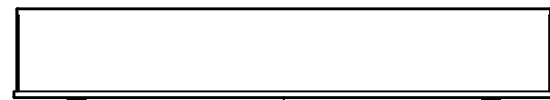

BOTTOM

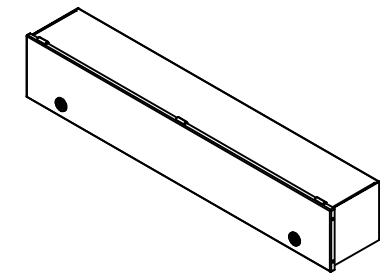

Isometric View

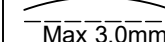
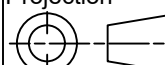

| No. | Revisions | Date | By/Par |
|-----|-----------|------|--------|
|     |           |      |        |
|     |           |      |        |
|     |           |      |        |
|     |           |      |        |

|  |   |   |
|--|---|---|
|  Tél: (450) 979-4373<br>Fax: (450) 979-4626<br><a href="http://www.exmweb.com">www.exmweb.com</a> |   | Flatness<br>Aplatissement<br> Max 3.0mm<br>Projection<br> |
| Customer<br>Client   | Date                                      |   |
| Drawn By<br>Dessiné Par  | BoxCad: BoxCad                            | Date 20-May-15  |
| Material<br>Matière  | 16 Ga Cold Rolled A1008 CS Type B (1.4mm) |   |
| Color<br>Couleur   | Asa-61 Grey                               | Finish<br>Fini Smooth   |
| Description<br>1100WEN 6" x 6" x 36" Assembly  |   | Detail Rev.   |
| Part Number<br>Numéro Pièce  | 1100WE060636N                             | Rev. 1<br>0   |

SEE BILL OF MATERIAL ON LAST PAGE

This drawing is confidential and must not be reproduced or used without the consent of EXM

Ce dessin est confidentiel et ne doit pas être reproduit ou utilisé sans le consentement de EXM

| NOTE |  |
|------|--|
| ITEM | DESCRIPTION                                    |
| 1    | NEMA 1 Enclosure                               |
| 2    | C/W Standard ground provision on box and cover |
| 3    | W/O Standard door stiffener                    |
| 4    | W/O Inner panel                                |
| 5    | W/O Inner panel mounting provision             |

| No. | Revisions | Date | By/Par |
|-----|-----------|------|--------|
|     |           |      |        |
|     |           |      |        |
|     |           |      |        |
|     |           |      |        |
|     |           |      |        |
|     |           |      |        |

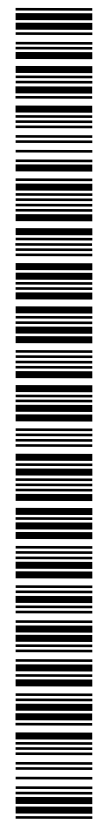
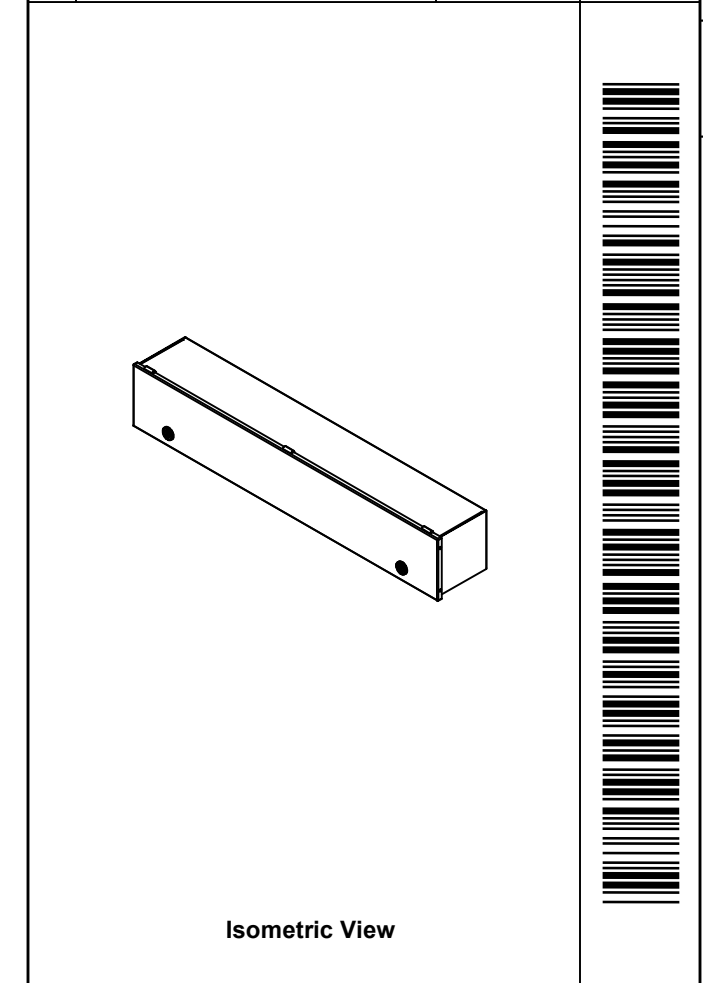

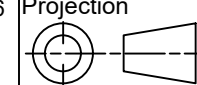
|  |   |   |
|--|---|---|
|  Tél: (450) 979-4373<br>Fax: (450) 979-4626<br><a href="http://www.exmweb.com">www.exmweb.com</a> |   | Flatness<br>Aplatissement<br>Max 3.0mm<br>Projection<br> |
| Customer<br>Client   | Date                                      |   |
| Drawn By<br>Dessiné Par  | BoxCad: BoxCad                            | Date 20-May-15  |
| Material<br>Matière  | 16 Ga Cold Rolled A1008 CS Type B (1.4mm) |   |
| Color<br>Couleur   | Asa-61 Grey                               | Finish<br>Fini Smooth   |
| Description<br>1100WEN 6" x 6" x 36" Assembly  |   | Detail Rev.   |
| Part Number<br>Numéro Pièce  |   | Rev. 2  |
| <b>1100WE060636N</b>   |   | <b>0</b>  |

| PACKING              |     |   |
|----------------------|-----|---|
| ITEM                 | QTY | DESCRIPTION                             |
| Thermal plastic film | 1   | Use with Packing Tunnel Wrapper Machine |
| Packaging label      | 1   | White label with product number         |

| Qty        | Part Number    | Rev | Description                |
|------------|----------------|-----|----------------------------|
| 1          | 1100WE060636NC | 0   | 1100WEN 6" x 36" Cover     |
| 1          | 1100WE060636NB | 0   | 1100WEN 6" x 6" x 36" Body |
| Parts List |                |     |                            |

This drawing is confidential and must not be reproduced or used without the consent of EXM

Ce dessin est confidentiel et ne doit pas être reproduit ou utilisé sans le consentement de EXM

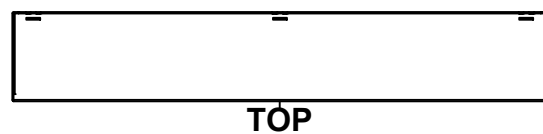

TOP



BACK

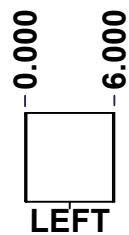

LEFT

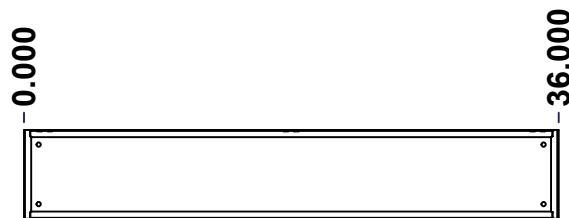

FRONT

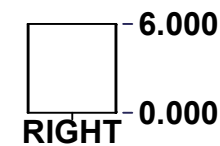

RIGHT



BOTTOM

| No. | Revisions | Date | By/Par |
|-----|-----------|------|--------|
|     |           |      |        |
|     |           |      |        |
|     |           |      |        |
|     |           |      |        |
|     |           |      |        |

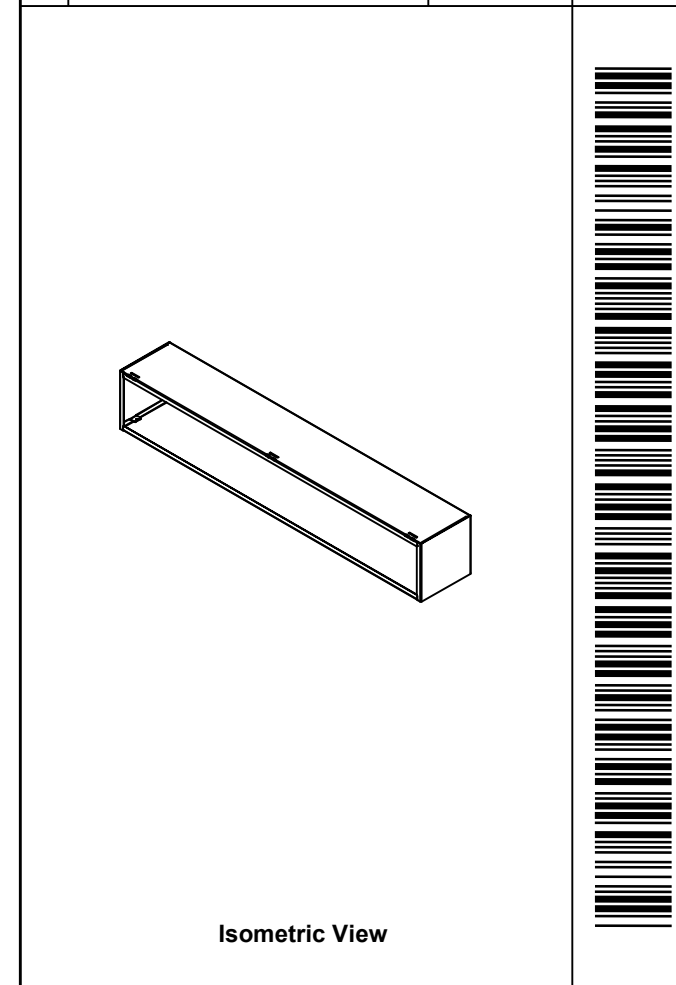

Isometric View

|  |                       |   |
|--|-----------------------|---|
|  Tél: (450) 979-4373<br>Fax: (450) 979-4626<br><a href="http://www.exmweb.com">www.exmweb.com</a> |                       | Flatness<br>Aplatissement<br>Max 3.0mm  |
| Customer Client  |                       | Projection<br> |
| Drawn By / Dessiné Par: BoxCad: BoxCad   |                       | Date: 20-May-15   |
| Material / Matière: 16 Ga Cold Rolled A1008 CS Type B (1.4mm)  |                       |   |
| Color / Couleur: Asa-61 Grey   | Finish / Fini: Smooth |   |
| Description: 1100WEN 6" x 6" x 36" Body  |                       | Detail Rev.   |
| Part Number / Numéro Pièce: 1100WE060636NB   |                       | Rev. 3<br>0   |

SEE BILL OF MATERIAL ON LAST PAGE

This drawing is confidential and must not be reproduced or used without the consent of EXM

Ce dessin est confidentiel et ne doit pas être reproduit ou utilisé sans le consentement de EXM

| STANDARD FEATURES ARE NOT LISTED IN THIS HOLE TABLE |        |       |             |
|---|--------|-------|-------------|
| HOLE TABLE - BACK VIEW (CUSTOM FEATURE ONLY)        |        |       |             |
| CUT-OUT   | XDIM   | YDIM  | DESCRIPTION |
| 1   | 35.000 | 1.000 | RND Ø0.290  |
| 2   | 35.000 | 5.000 | RND Ø0.290  |
| 3   | 1.000  | 5.000 | RND Ø0.290  |
| 4   | 1.000  | 1.000 | RND Ø0.290  |

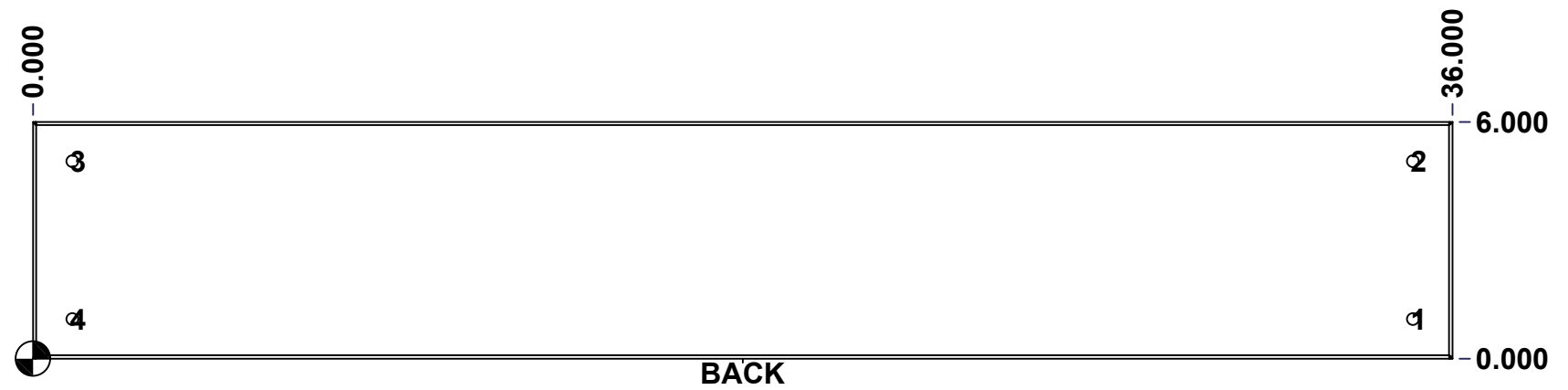

|  |                             |          |     |
|--|-----------------------------|----------|-----|
|  | Description                 | Status   |     |
|  | 1100WEN 6" x 6" x 36" Body  | (NULL)   |     |
|  | Part Number<br>Numéro Pièce | Rev.     |     |
|  | <b>1100WE060636NB</b>       | <b>0</b> | 4/8 |

This drawing is confidential and must not be reproduced or used without the consent of EXM

Ce dessin est confidentiel et ne doit pas être reproduit ou utilisé sans le consentement de EXM

| No. | Revisions | Date | By/Par |
|-----|-----------|------|--------|
|     |           |      |        |
|     |           |      |        |
|     |           |      |        |
|     |           |      |        |
|     |           |      |        |

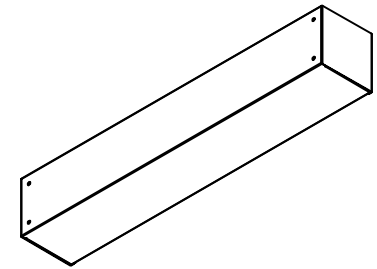

Isometric View

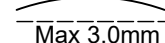
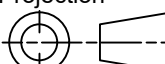

|  |                       |   |
|--|-----------------------|---|
|  Tél: (450) 979-4373<br>Fax: (450) 979-4626<br><a href="http://www.exmweb.com">www.exmweb.com</a> |                       | Flatness<br>Aplatissement<br><br>Max 3.0mm |
| Customer<br>Client   |                       | Projection<br>                             |
| Drawn By<br>Dessiné Par BoxCad: BoxCad   |                       | Date 20-May-15  |
| Material<br>Matière 16 Ga Cold Rolled A1008 CS Type B (1.4mm)  |                       |   |
| Color<br>Couleur Asa-61 Grey   | Finish<br>Fini Smooth |   |
| Description<br>1100WEN 6" x 6" x 36" Body  |                       | Detail Rev.   |
| Part Number<br>Numéro Pièce<br><b>1100WE060636NB</b>   |                       | Rev. 5<br><b>0</b>  |

| Qty        | Part Number      | Rev | Description                         |
|------------|------------------|-----|-------------------------------------|
| 1          | 1100WE060636NB-P | 0   | 1100WEN 6" x 6" x 36" Body Part     |
| 1          | STK-P-02400S     | 0   | Powder Paint (Asa-61 Grey / Smooth) |
| Parts List |                  |     |                                     |

This drawing is confidential and must not be reproduced or used without the consent of EXM

Ce dessin est confidentiel et ne doit pas être reproduit ou utilisé sans le consentement de EXM

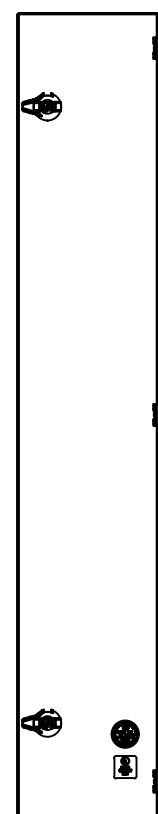
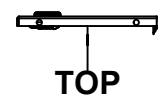

BACK

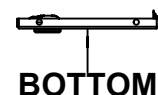

BOTTOM

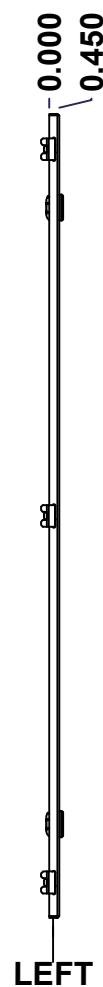

LEFT

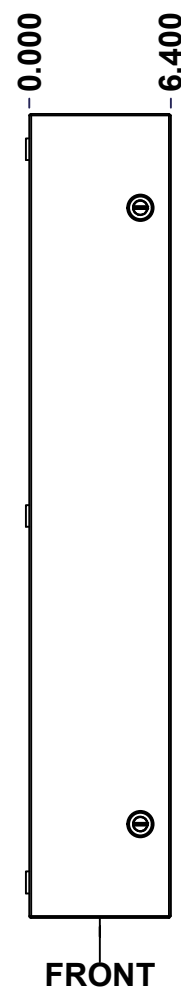

FRONT

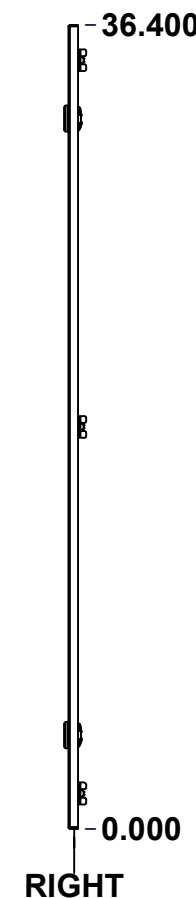

RIGHT



Isometric View



| No. | Revisions | Date | By/Par |
|-----|-----------|------|--------|
|     |           |      |        |
|     |           |      |        |
|     |           |      |        |
|     |           |      |        |
|     |           |      |        |

|  |   |  |
|--|---|--|
|  Tél: (450) 979-4373<br>Fax: (450) 979-4626<br><a href="http://www.exmweb.com">www.exmweb.com</a> |   | Flatness<br>Aplatissement<br><br>Max 3.0mm<br>Projection<br> |
| Customer Client  | Date                                      |  |
| Drawn By<br>Dessiné Par  | BoxCad: BoxCad                            | Date 20-May-15   |
| Material<br>Matière  | 16 Ga Cold Rolled A1008 CS Type B (1.4mm) |  |
| Color<br>Couleur   | Asa-61 Grey                               | Finish<br>Fini Smooth  |
| Description  | Detail Rev.                               |  |
| 1100WEN 6" x 36" Cover   |   |  |
| Part Number<br>Numéro Pièce  | Rev.                                      | 6  |
| 1100WE060636NC   | 0   | 8  |

SEE BILL OF MATERIAL ON LAST PAGE

This drawing is confidential and must not be reproduced or used without the consent of EXM

Ce dessin est confidentiel et ne doit pas être reproduit ou utilisé sans le consentement de EXM

| STANDARD FEATURES ARE NOT LISTED IN THIS HOLE TABLE |        |       |                           |
|---|--------|-------|---------------------------|
| HOLE TABLE - FRONT VIEW (CUSTOM FEATURE ONLY)       |        |       |                           |
| CUT-OUT   | XDIM   | YDIM  | DESCRIPTION               |
| 1   | 4.250  | 1.375 | LOCK 880 SCQ1-SL @ 270.0° |
| 2   | 32.150 | 1.375 | LOCK 880 SCQ1-SL @ 270.0° |

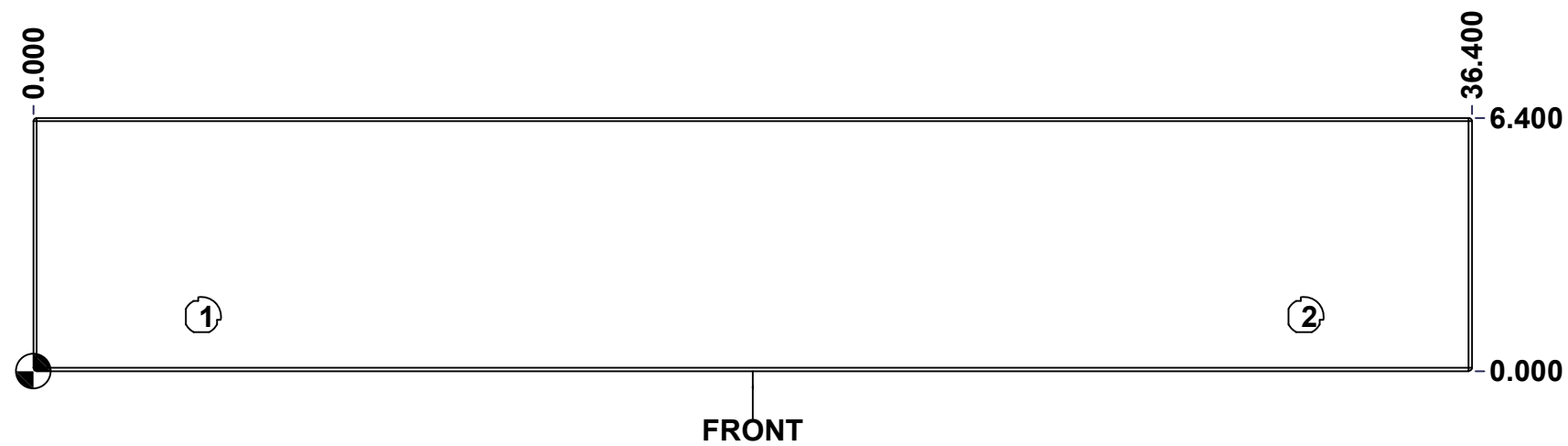

|  |                             |          |     |
|--|-----------------------------|----------|-----|
|  | Description                 | Status   |     |
|  | 1100WEN 6" x 36" Cover      | (NULL)   |     |
|  | Part Number<br>Numéro Pièce | Rev.     |     |
|  | <b>1100WE060636NC</b>       | <b>0</b> | 7/8 |

This drawing is confidential and must not be reproduced or used without the consent of EXM

Ce dessin est confidentiel et ne doit pas être reproduit ou utilisé sans le consentement de EXM

| No. | Revisions | Date | By/Par |
|-----|-----------|------|--------|
|     |           |      |        |
|     |           |      |        |
|     |           |      |        |
|     |           |      |        |
|     |           |      |        |

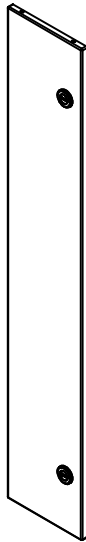

**Isometric View**

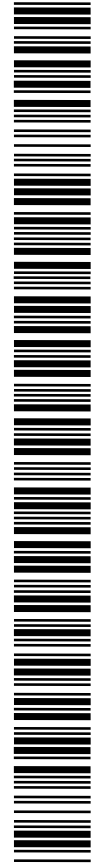



Tél: (450) 979-4373  
Fax: (450) 979-4626  
[www.exmweb.com](http://www.exmweb.com)

Flatness  
Aplatissement  
Max 3.0mm

Projection



|   |                 |
|---|-----------------|
| Customer Client   | Date            |
| Drawn By / Dessiné Par: BoxCad: BoxCad                        | Date: 20-May-15 |
| Material / Matière: 16 Ga Cold Rolled A1008 CS Type B (1.4mm) |                 |

|   |                       |
|---|-----------------------|
| Color / Couleur: Asa-61 Grey                      | Finish / Fini: Smooth |
| Description: 1100WEN 6" x 36" Cover               | Detail Rev.           |
| Part Number / Numéro Pièce: <b>1100WE060636NC</b> | Rev. 0 / 8            |

| Qty        | Part Number      | Rev | Description                         |
|------------|------------------|-----|-------------------------------------|
| 1          | STK-S-00900      | 0   | UL Cut-Out Box Sticker              |
| 1          | STK-S-00800      | 2   | CSA Electrical Box Sticker          |
| 3          | STK-Q-33361      | 0   | Spring Steel Hinge                  |
| 1          | 1100WE060636NC-P | 0   | 1100WEN 6" x 36" Cover Part         |
| 1          | STK-P-02400S     | 0   | Powder Paint (Asa-61 Grey / Smooth) |
| 2          | 880 SCQ1-SL      | 0   | 1100 1/4 Turn Lock                  |
| Parts List |                  |     |                                     |