

This drawing is confidential and must not be reproduced or used without the consent of EXM

Ce dessin est confidentiel et ne doit pas être reproduit ou utilisé sans le consentement de EXM

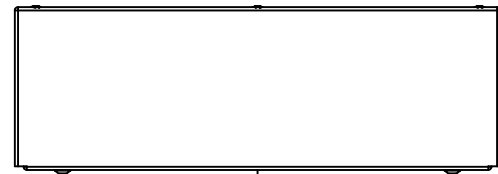

TOP

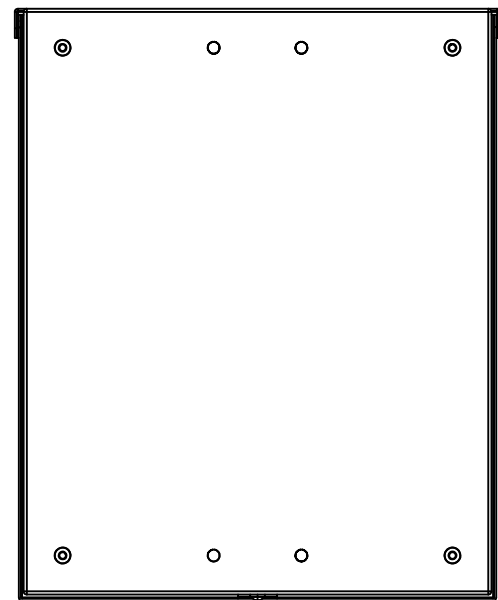

BACK

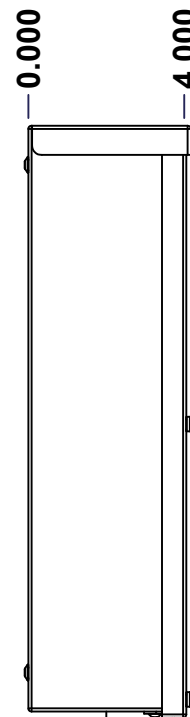

LEFT

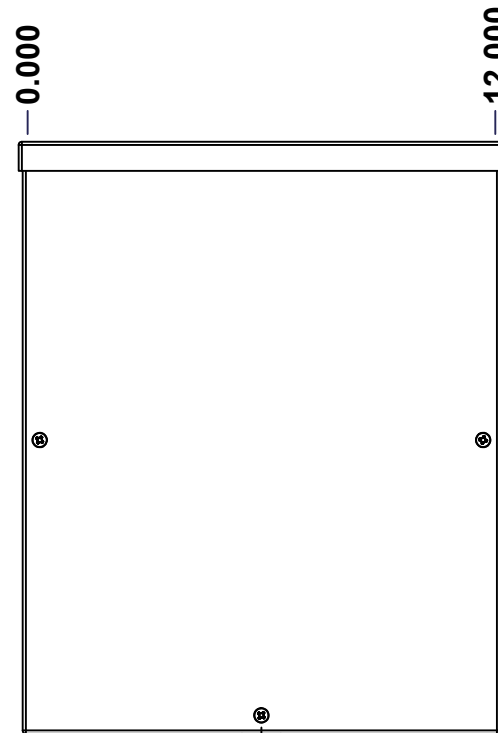

FRONT

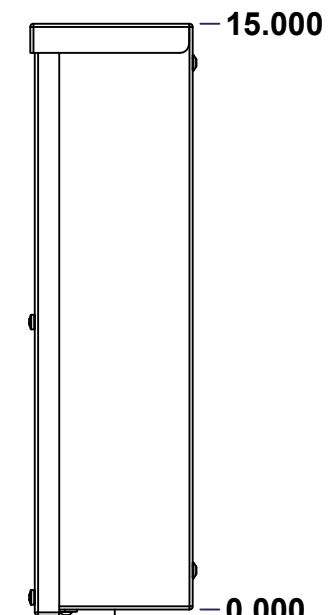

RIGHT

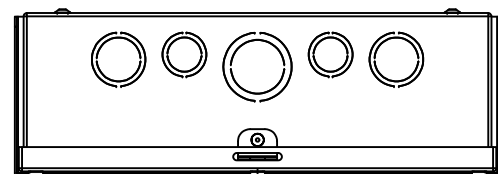

BOTTOM

| No. | Revisions | Date | By/Par |
|-----|-----------|------|--------|
|     |           |      |        |
|     |           |      |        |
|     |           |      |        |
|     |           |      |        |
|     |           |      |        |

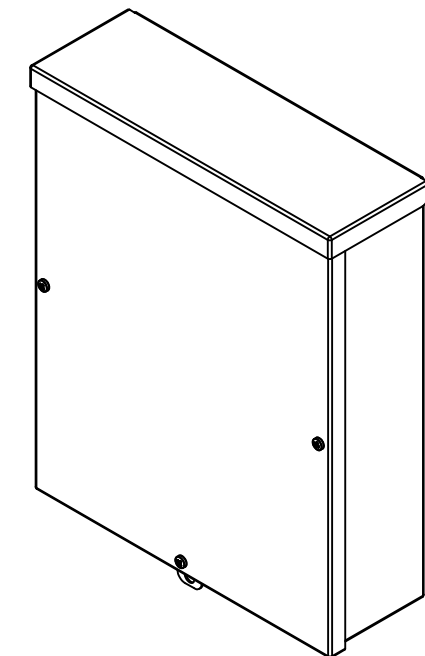

Isometric View

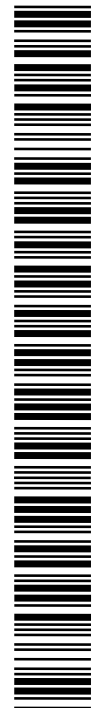

Tél: (450) 979-4373  
 Fax: (450) 979-4626  
[www.exmweb.com](http://www.exmweb.com)

Flatness  
Aplatissement  
Max 3.0mm  
Projection

|  |                       |
|--|-----------------------|
| Customer<br>Client                             | Date                  |
| Drawn By<br>Dessiné Par BoxCad: BoxCad         | Date 17-Oct-19        |
| Material<br>Matière 16 Ga Galvannealed (1.4mm) |                       |
| Color<br>Couleur Asa-61 Grey                   | Finish<br>Fini Smooth |
| Description<br>1300 15" x 12" x 4" Assembly    | Detail Rev.           |

SEE BILL OF MATERIAL ON LAST PAGE

|                             |          |   |
|-----------------------------|----------|---|
| Part Number<br>Numéro Pièce | Rev.     | 1 |
| <b>1300151204</b>           | <b>0</b> | 2 |

This drawing is confidential and must not be reproduced or used without the consent of EXM

Ce dessin est confidentiel et ne doit pas être reproduit ou utilisé sans le consentement de EXM

| NOTE |                                    |
|------|------------------------------------|
| ITEM | DESCRIPTION                        |
| 1    | NEMA 3/3R Enclosure                |
| 2    | W/O Standard door stiffener        |
| 3    | W/O Inner panel                    |
| 4    | W/O Inner panel mounting standoffs |

| No. | Revisions | Date | By/Par |
|-----|-----------|------|--------|
|     |           |      |        |
|     |           |      |        |
|     |           |      |        |
|     |           |      |        |
|     |           |      |        |
|     |           |      |        |

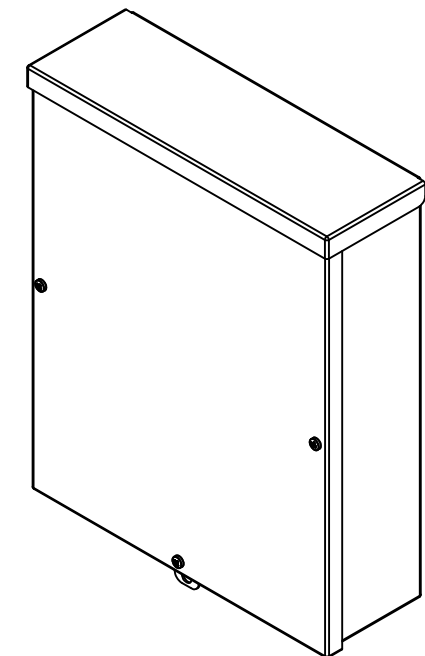

Isometric View



Tél: (450) 979-4373  
 Fax: (450) 979-4626  
[www.exmweb.com](http://www.exmweb.com)

Flatness  
Aplatissement  
Max 3.0mm  
Projection

|  |                       |
|--|-----------------------|
| Customer Client                                | Date                  |
| Drawn By / Dessiné Par: BoxCad: BoxCad         | Date: 17-Oct-19       |
| Material / Matière: 16 Ga Galvannealed (1.4mm) |                       |
| Color / Couleur: Asa-61 Grey                   | Finish / Fini: Smooth |

| PACKING              |     |   |
|----------------------|-----|---|
| ITEM                 | QTY | DESCRIPTION                             |
| Thermal plastic film | 1   | Use with Packing Tunnel Wrapper Machine |
| Packaging label      | 1   | White label with product number         |

| Qty        | Part Number | Rev | Description              |
|------------|-------------|-----|--------------------------|
| 1          | STK-K-03100 | 3   | 1300 Accessory Kit       |
| 1          | 1300151204C | 1   | 1300 15" x 12" Cover     |
| 1          | 1300151204B | 0   | 1300 15" x 12" x 4" Body |
| Parts List |             |     |                          |

|   |             |
|---|-------------|
| Description: 1300 15" x 12" x 4" Assembly     | Detail Rev. |
| Part Number / Numéro Pièce: <b>1300151204</b> | Rev. 0      |
|   | 2           |

This drawing is confidential and must not be reproduced or used without the consent of EXM

Ce dessin est confidentiel et ne doit pas être reproduit ou utilisé sans le consentement de EXM

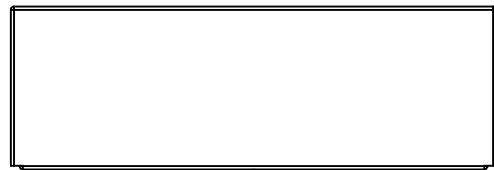

TOP

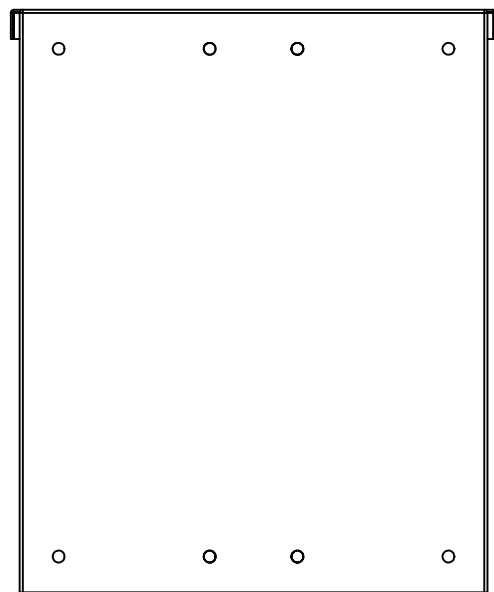

BACK

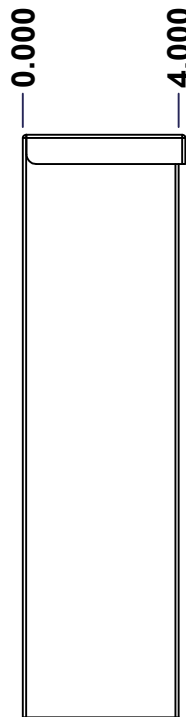

LEFT

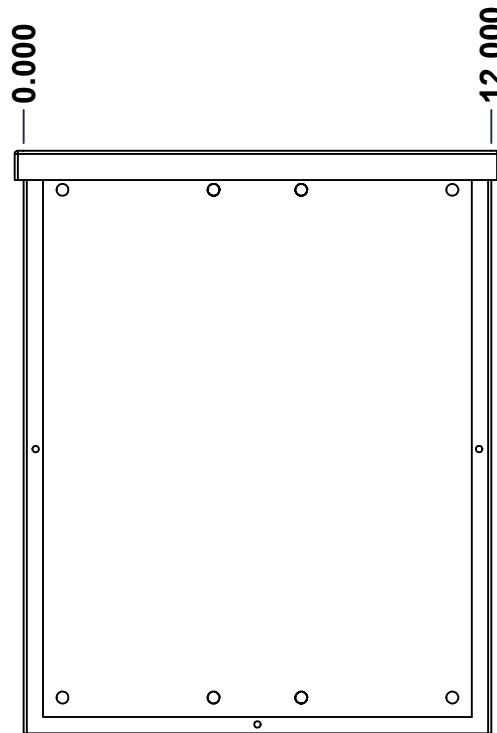

FRONT

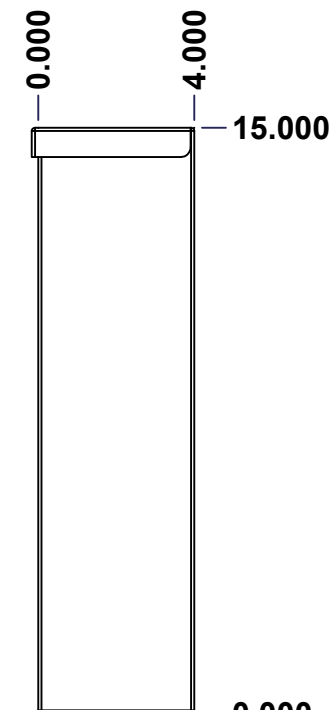

RIGHT

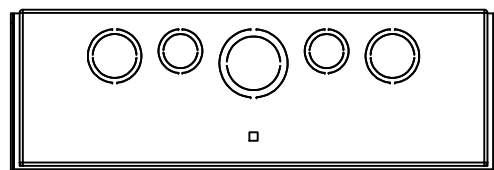

BOTTOM

| No. | Revisions | Date | By/Par |
|-----|-----------|------|--------|
|     |           |      |        |
|     |           |      |        |
|     |           |      |        |
|     |           |      |        |

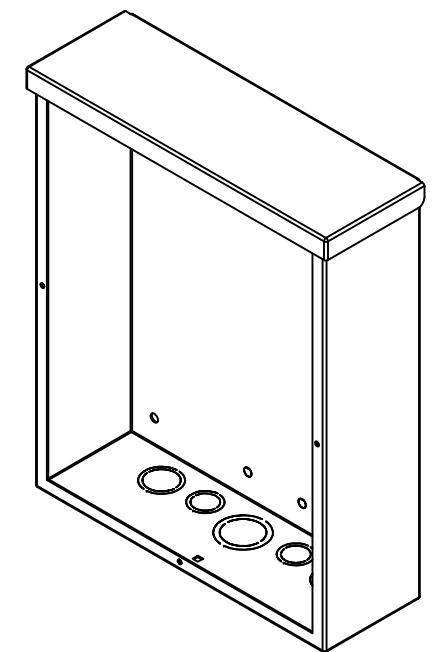

Isometric View



Tél: (450) 979-4373  
 Fax: (450) 979-4626  
[www.exmweb.com](http://www.exmweb.com)

Flatness  
Aplatissement

Max 3.0mm

Projection

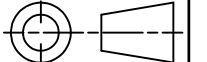

|  |                       |
|--|-----------------------|
| Customer Client                                | Date                  |
| Drawn By<br>Dessiné Par BoxCad: BoxCad         | Date 17-Oct-19        |
| Material<br>Matière 16 Ga Galvannealed (1.4mm) |                       |
| Color<br>Couleur Asa-61 Grey                   | Finish<br>Fini Smooth |
| Description<br>1300 15" x 12" x 4" Body        | Detail Rev.           |
| Part Number<br>Numéro Pièce <b>1300151204B</b> | Rev. <b>0</b>         |

SEE BILL OF MATERIAL ON LAST PAGE

1  
7

This drawing is confidential and must not be reproduced or used without the consent of EXM

Ce dessin est confidentiel et ne doit pas être reproduit ou utilisé sans le consentement de EXM

**STANDARD FEATURES ARE NOT LISTED IN THIS HOLE TABLE**

**HOLE TABLE - BOTTOM VIEW (CUSTOM FEATURE ONLY)**

| CUT-OUT | XDIM  | YDIM  | DESCRIPTION        |
|---------|-------|-------|--------------------|
| 1       | 9.563 | 1.188 | DKO Ø1.375 - 1.125 |
| 2       | 7.875 | 1.063 | DKO Ø1.125 - 0.875 |
| 3       | 6.000 | 1.375 | DKO Ø1.750 - 1.375 |
| 4       | 4.125 | 1.063 | DKO Ø1.125 - 0.875 |
| 5       | 2.437 | 1.188 | DKO Ø1.375 - 1.125 |

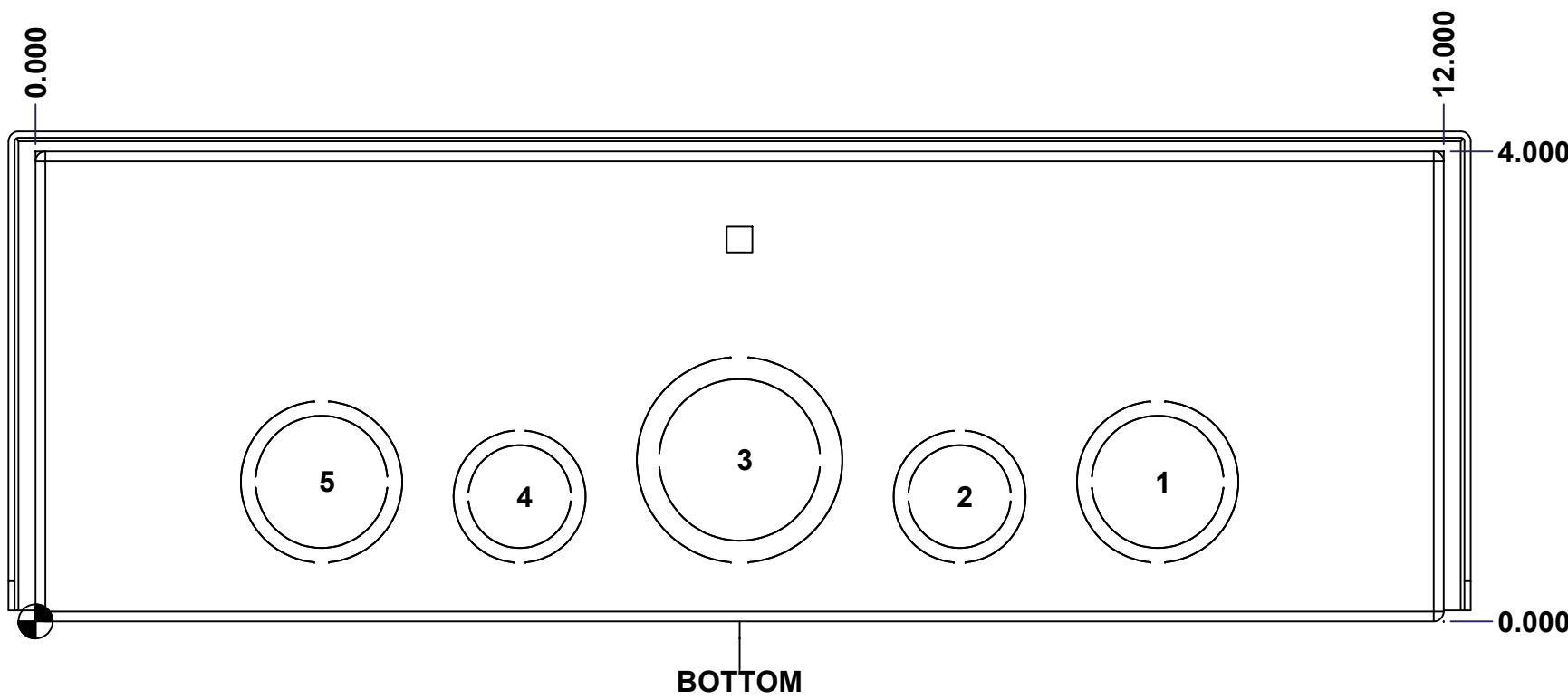

|  |                             |          |       |
|--|-----------------------------|----------|-------|
|  | Description                 | Status   |       |
|  | 1300 15" x 12" Body         | (NULL)   |       |
|  | Part Number<br>Numéro Pièce | Rev.     |       |
|  | <b>1300151204B</b>          | <b>0</b> | 4 / 7 |

This drawing is confidential and must not be reproduced or used without the consent of EXM

Ce dessin est confidentiel et ne doit pas être reproduit ou utilisé sans le consentement de EXM

| No. | Revisions | Date | By/Par |
|-----|-----------|------|--------|
|     |           |      |        |
|     |           |      |        |
|     |           |      |        |
|     |           |      |        |
|     |           |      |        |

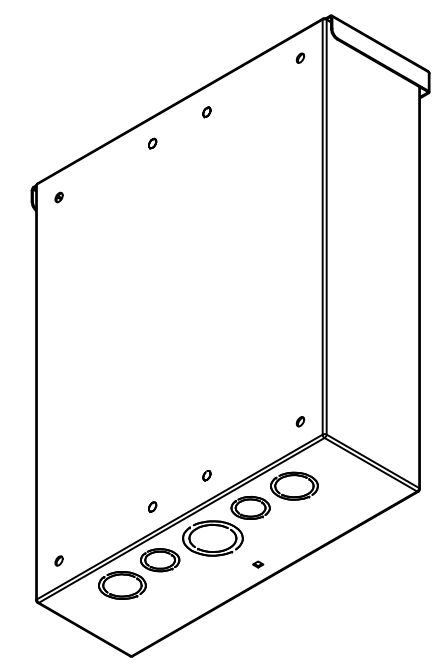

Isometric View

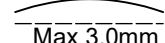
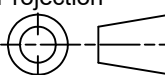

|  |  |   |             |
|--|--|---|-------------|
|  Tél: (450) 979-4373<br>Fax: (450) 979-4626<br><a href="http://www.exmweb.com">www.exmweb.com</a> |  | Flatness<br>Aplatissement<br> Max 3.0mm<br>Projection<br> |             |
| Customer Client  |  | Date  |             |
| Drawn By / Dessiné Par: BoxCad: BoxCad   |  | Date: 17-Oct-19   |             |
| Material / Matière: 16 Ga Galvannealed (1.4mm)   |  |   |             |
| Color / Couleur: Asa-61 Grey   |  | Finish / Fini: Smooth   |             |
| Description: 1300 15" x 12" x 4" Body  |  |   | Detail Rev. |
| Part Number / Numéro Pièce: <b>1300151204B</b>   |  | Rev.:   | 7           |
|  |  | <b>0</b>  | 7           |

| Qty        | Part Number   | Rev | Description                         |
|------------|---------------|-----|-------------------------------------|
| 1          | STK-P-02400S  | 0   | Powder Paint (Asa-61 Grey / Smooth) |
| 1          | 1300151204B-P | 0   | 1300 15" x 12" Body Part            |
| Parts List |               |     |                                     |

This drawing is confidential and must not be reproduced or used without the consent of EXM

Ce dessin est confidentiel et ne doit pas être reproduit ou utilisé sans le consentement de EXM

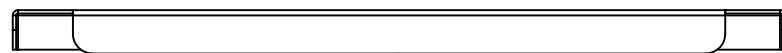

TOP

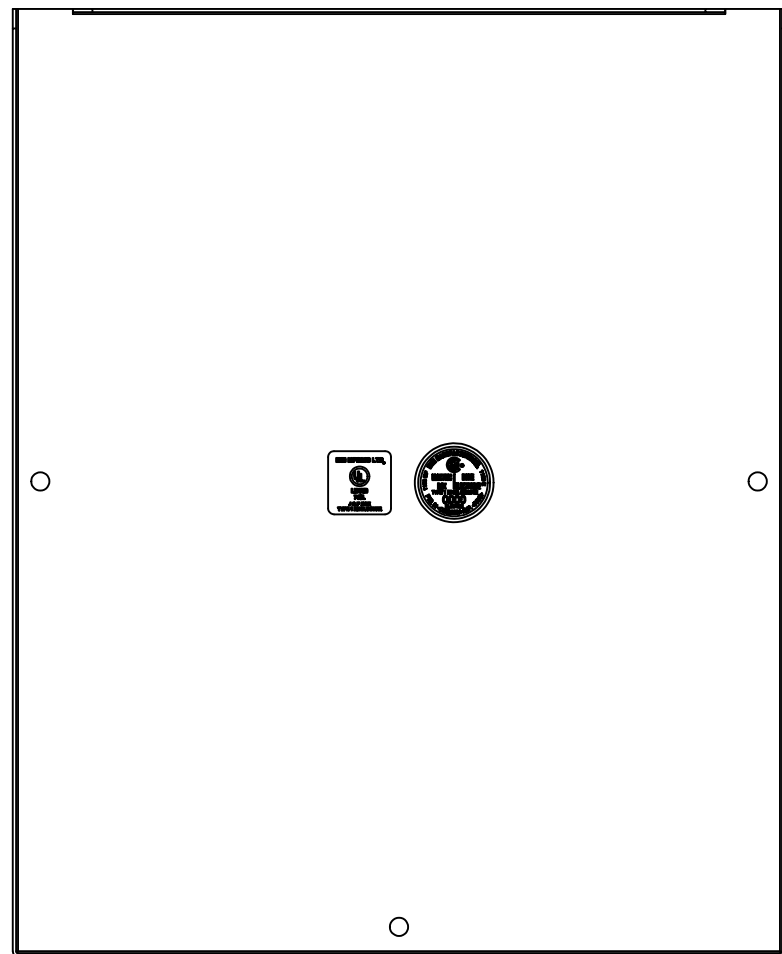

BACK

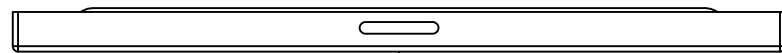

BOTTOM

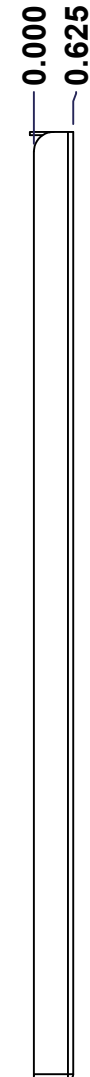

LEFT

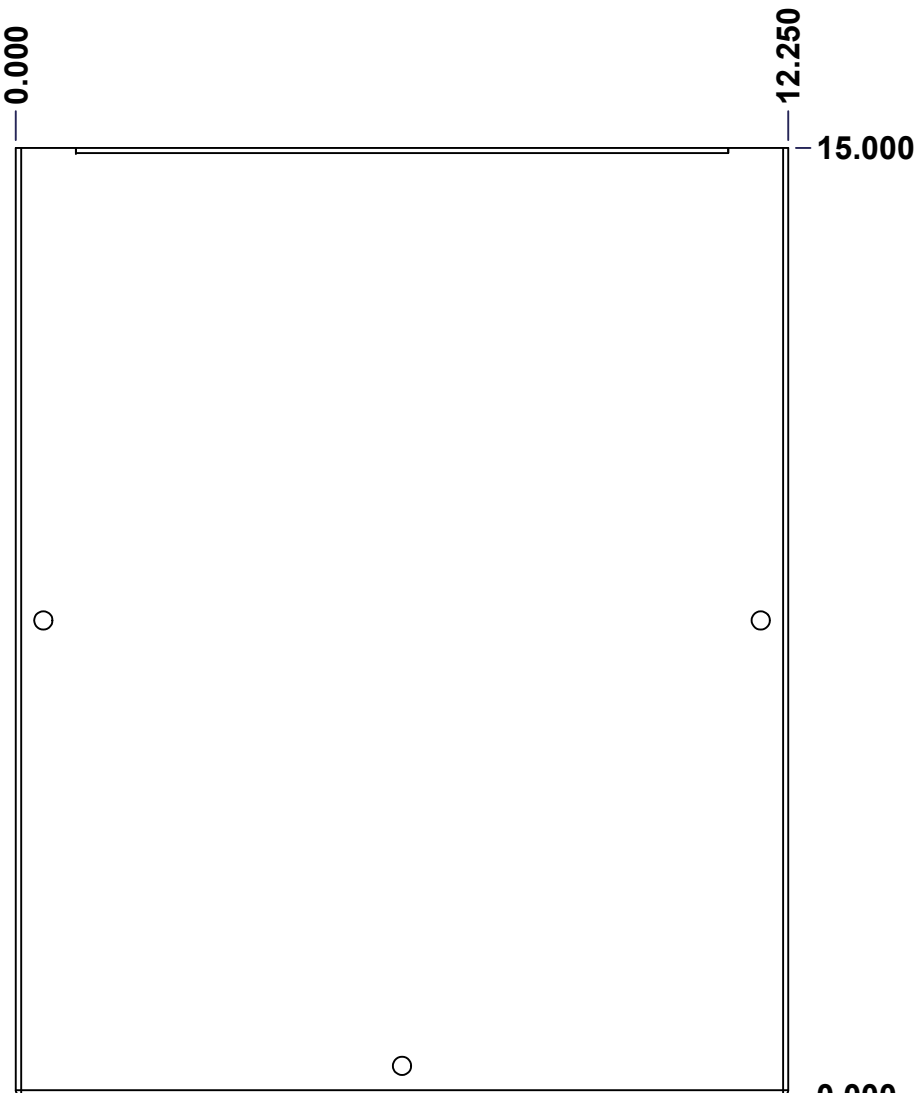

FRONT



RIGHT

| No. | Revisions | Date | By/Par |
|-----|-----------|------|--------|
|     |           |      |        |
|     |           |      |        |
|     |           |      |        |
|     |           |      |        |

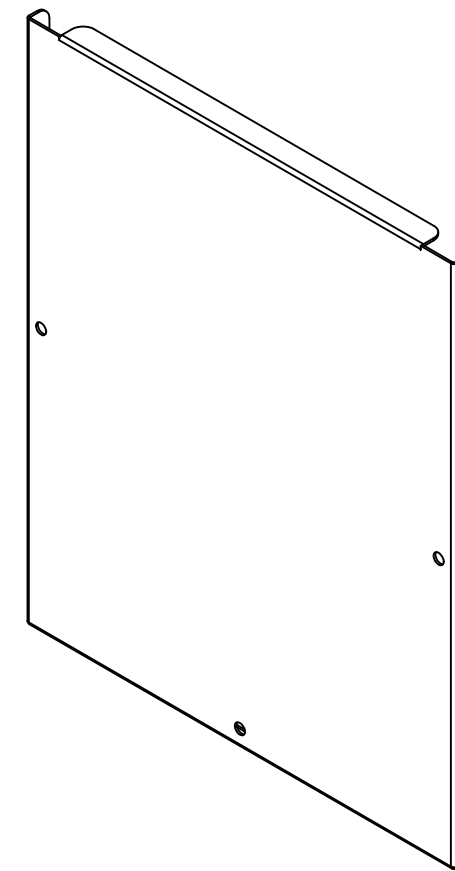

Isometric View



Tél: (450) 979-4373  
 Fax: (450) 979-4626  
[www.exmweb.com](http://www.exmweb.com)

Flatness  
Aplatissement

Max 3.0mm

Projection

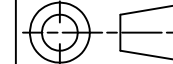

|  |                 |
|--|-----------------|
| Customer Client                        | Date            |
| Drawn By / Dessiné Par: BoxCad: BoxCad | Date: 17-Oct-19 |

Material / Matière: 16 Ga Galvannealed (1.4mm)

|                              |                       |
|------------------------------|-----------------------|
| Color / Couleur: Asa-61 Grey | Finish / Fini: Smooth |
|------------------------------|-----------------------|

|                                   |             |
|-----------------------------------|-------------|
| Description: 1300 15" x 12" Cover | Detail Rev. |
|-----------------------------------|-------------|

|   |        |   |
|---|--------|---|
| Part Number / Numéro Pièce: 1300151204C | Rev. 1 | 1 |
|   |        | 3 |

SEE BILL OF MATERIAL ON LAST PAGE

This drawing is confidential and must not be reproduced or used without the consent of EXM

Ce dessin est confidentiel et ne doit pas être reproduit ou utilisé sans le consentement de EXM

| No. | Revisions | Date | By/Par |
|-----|-----------|------|--------|
|     |           |      |        |
|     |           |      |        |
|     |           |      |        |
|     |           |      |        |
|     |           |      |        |

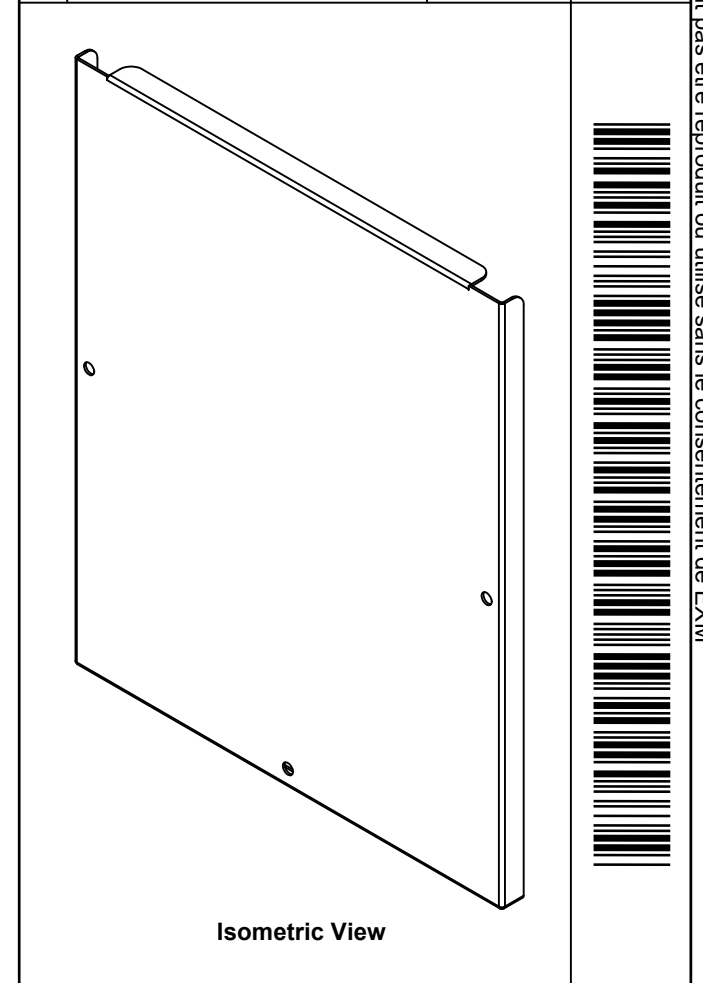

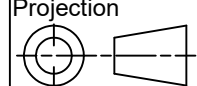
|  |                            |   |
|--|----------------------------|---|
|  Tél: (450) 979-4373<br>Fax: (450) 979-4626<br><a href="http://www.exmweb.com">www.exmweb.com</a> |                            | Flatness<br>Aplatissement<br>Max 3.0mm<br>Projection<br> |
| Customer<br>Client   | Date                       |   |
| Drawn By<br>Dessiné Par  | BoxCad: BoxCad             | Date 17-Oct-19  |
| Material<br>Matière  | 16 Ga Galvannealed (1.4mm) |   |
| Color<br>Couleur   | Asa-61 Grey                | Finish<br>Fini Smooth   |
| Description  | 1300 15" x 12" Cover       | Detail Rev.   |
| Part Number<br>Numéro Pièce  | <b>1300151204C</b>         | Rev. 3  |
| Qty Part Number Rev Description<br>Parts List  |                            | 1<br><b>1</b>   |

|            |               |     |                                     |
|------------|---------------|-----|-------------------------------------|
| 1          | STK-S-00950   | 1   | UL 74SL Pull-Box Sticker            |
| 1          | STK-S-00800   | 2   | CSA Electrical Box Sticker          |
| 1          | STK-P-02400S  | 0   | Powder Paint (Asa-61 Grey / Smooth) |
| 1          | 1300151204C-P | 0   | 1300 15" x 12" Cover Part           |
| Qty        | Part Number   | Rev | Description                         |
| Parts List |               |     |                                     |