

This drawing is confidential and must not be reproduced or used without the consent of EXM

Ce dessin est confidentiel et ne doit pas être reproduit ou utilisé sans le consentement de EXM

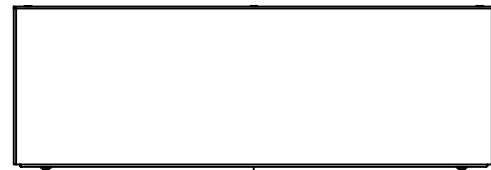

TOP

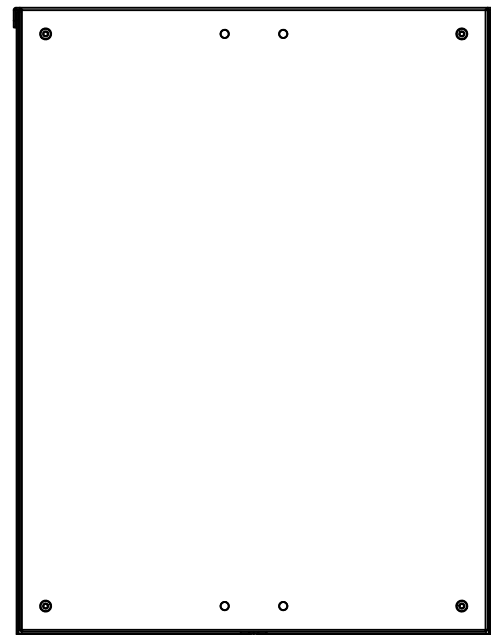

BACK

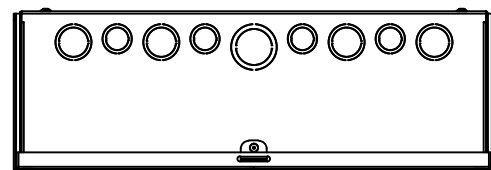

BOTTOM

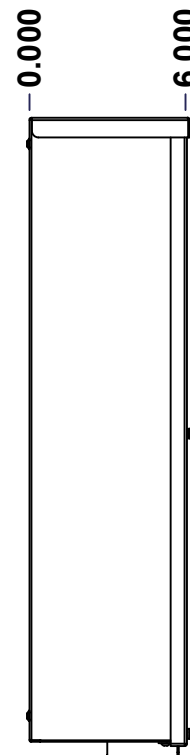

LEFT

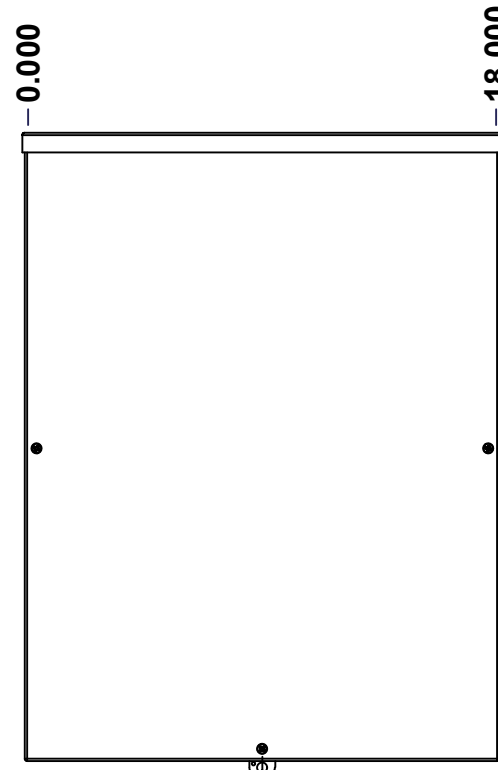

FRONT

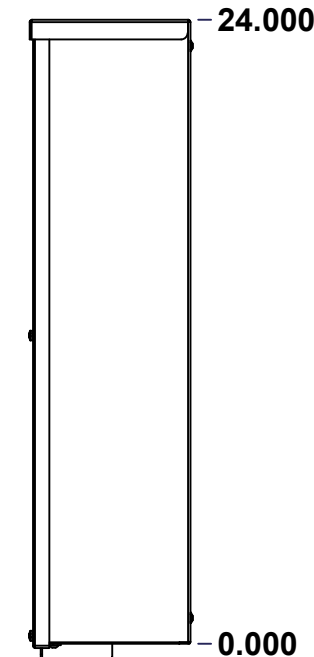

RIGHT

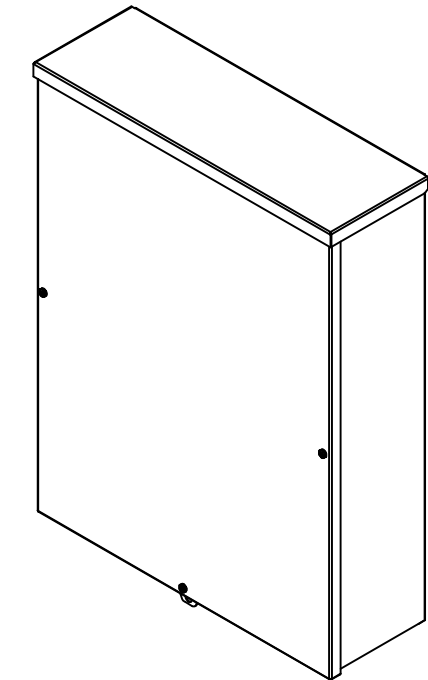

Isometric View

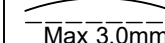
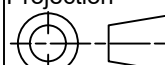

| No. | Revisions | Date | By/Par |
|-----|-----------|------|--------|
| | | | |
| | | | |
| | | | |
| | | | |
| | | | |

| | | |
|--|------------------------------|---|
|  Tél: (450) 979-4373 Fax: (450) 979-4626 www.exmweb.com | | Flatness Aplatissement  Max 3.0mm Projection  |
| Customer Client | | Date |
| Drawn By Dessiné Par | BoxCad: BoxCad | Date 17-Oct-19 |
| Material Matière | 16 Ga H.R.P. & O. (1.4mm) | |
| Color Couleur | Asa-61 Grey | Finish Fini Smooth |
| Description | 1300 24" x 18" x 6" Assembly | |
| Part Number Numéro Pièce | 1300241806 | Detail Rev. Rev. 1 0 / 7 |

SEE BILL OF MATERIAL ON LAST PAGE

This drawing is confidential and must not be reproduced or used without the consent of EXM

Ce dessin est confidentiel et ne doit pas être reproduit ou utilisé sans le consentement de EXM

| NOTE | |
|------|------------------------------------|
| ITEM | DESCRIPTION |
| 1 | NEMA 3/3R Enclosure |
| 2 | W/O Standard door stiffener |
| 3 | W/O Inner panel |
| 4 | W/O Inner panel mounting standoffs |

| No. | Revisions | Date | By/Par |
|-----|-----------|------|--------|
| | | | |
| | | | |
| | | | |
| | | | |
| | | | |
| | | | |

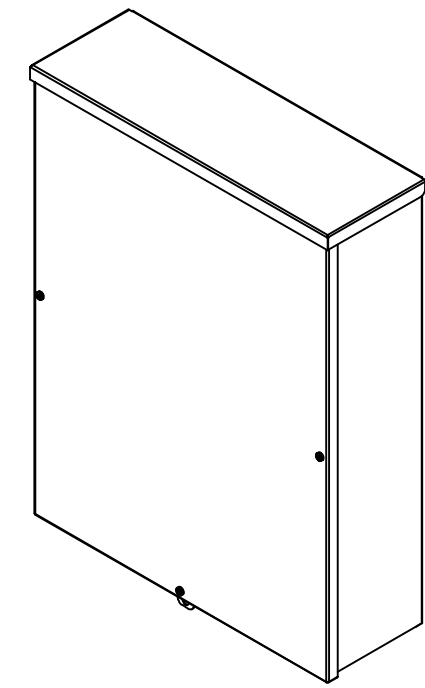

Isometric View



Tél: (450) 979-4373
 Fax: (450) 979-4626
www.exmweb.com



| | |
|---|-----------------------|
| Customer Client | Date |
| Drawn By / Dessiné Par: BoxCad: BoxCad | Date: 17-Oct-19 |
| Material / Matière: 16 Ga H.R.P. & O. (1.4mm) | |
| Color / Couleur: Asa-61 Grey | Finish / Fini: Smooth |

| PACKING | | |
|-----------------------|-----|--|
| ITEM | QTY | DESCRIPTION |
| Cardboard sleeve | 2 | Top and Bottom |
| Plastic strap - Black | 2 | To squeeze the 2 cardboard sleeve together |
| Thermal plastic film | 1 | Use with Packing Tunnel Wrapper Machine |
| Packaging label | 1 | White label with product number |

| Qty | Part Number | Rev | Description |
|------------|-------------|-----|--------------------------|
| 1 | STK-K-03100 | 3 | 1300 CH - Accessory Kit |
| 1 | 1300241806C | 0 | 1300 24" x 18" Cover |
| 1 | 1300241806B | 0 | 1300 24" x 18" x 6" Body |
| Parts List | | | |

| | |
|---|----------------|
| Description: 1300 24" x 18" x 6" Assembly | Detail Rev. |
| Part Number / Numéro Pièce: 1300241806 | Rev. 0 / 2 / 7 |

This drawing is confidential and must not be reproduced or used without the consent of EXM

Ce dessin est confidentiel et ne doit pas être reproduit ou utilisé sans le consentement de EXM



TOP

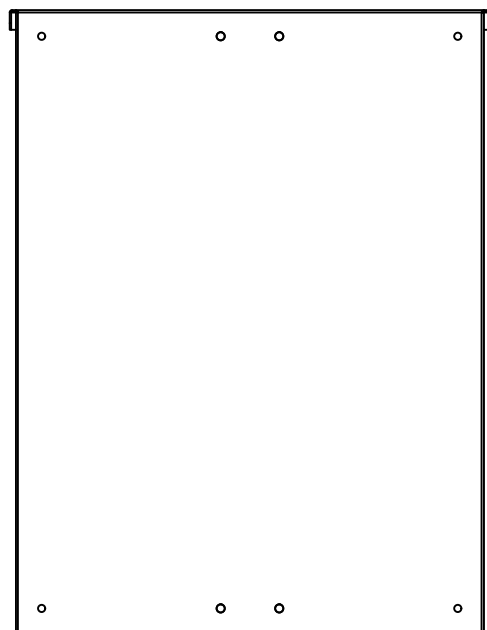

BACK

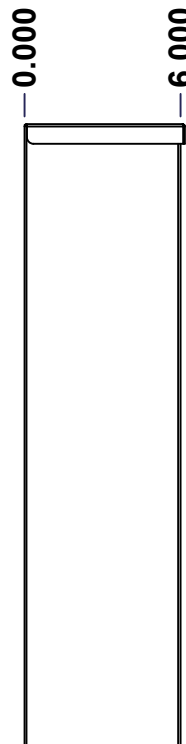

LEFT

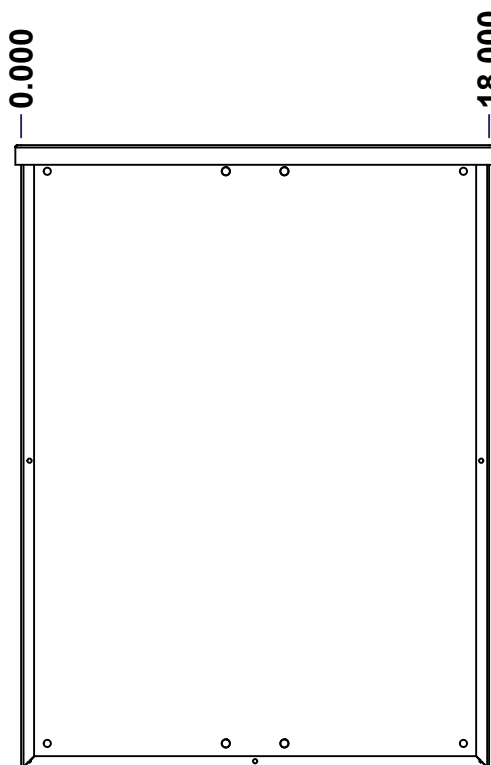

FRONT

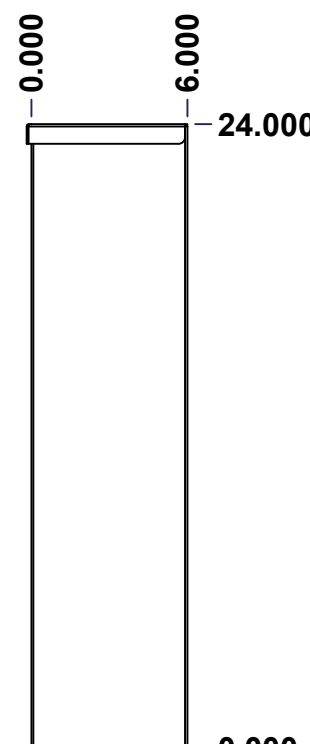

RIGHT

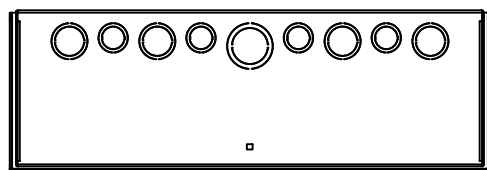

BOTTOM

| No. | Revisions | Date | By/Par |
|-----|-----------|------|--------|
| | | | |
| | | | |
| | | | |
| | | | |

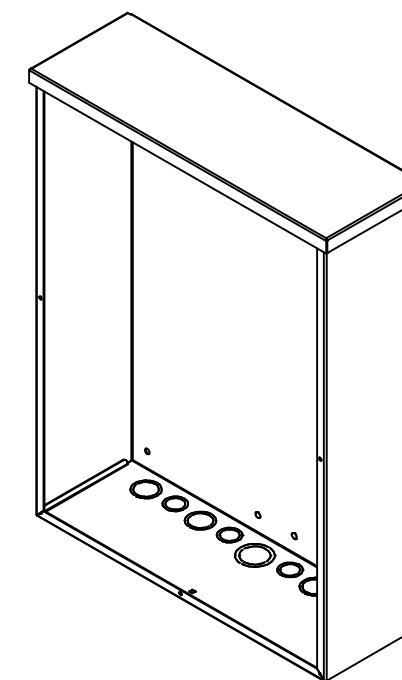

Isometric View

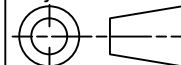

| | | |
|--|---------------------------|---|
|  Tél: (450) 979-4373 Fax: (450) 979-4626 www.exmweb.com | | Flatness Aplatissement Max 3.0mm Projection  |
| Customer Client | Date | |
| Drawn By Dessiné Par | BoxCad: BoxCad | Date 17-Oct-19 |
| Material Matière | 16 Ga H.R.P. & O. (1.4mm) | |
| Color Couleur | Asa-61 Grey | Finish Fini Smooth |
| Description | Detail Rev. | |
| 1300 24" x 18" x 6" Body | | |
| Part Number Numéro Pièce | Rev. | 3 |
| 1300241806B | 0 | 7 |

SEE BILL OF MATERIAL ON LAST PAGE

This drawing is confidential and must not be reproduced or used without the consent of EXM

Ce dessin est confidentiel et ne doit pas être reproduit ou utilisé sans le consentement de EXM

STANDARD FEATURES ARE NOT LISTED IN THIS HOLE TABLE

HOLE TABLE - BOTTOM VIEW (CUSTOM FEATURE ONLY)

| CUT-OUT | XDIM | YDIM | DESCRIPTION |
|---------|--------|-------|--------------------|
| 1 | 2.061 | 1.188 | DKO Ø1.375 - 1.125 |
| 2 | 10.875 | 1.063 | DKO Ø1.125 - 0.875 |
| 3 | 9.000 | 1.375 | DKO Ø1.750 - 1.375 |
| 4 | 7.125 | 1.063 | DKO Ø1.125 - 0.875 |
| 5 | 5.437 | 1.188 | DKO Ø1.375 - 1.125 |
| 6 | 3.749 | 1.063 | DKO Ø1.125 - 0.875 |
| 7 | 15.939 | 1.188 | DKO Ø1.375 - 1.125 |
| 8 | 14.251 | 1.063 | DKO Ø1.125 - 0.875 |
| 9 | 12.563 | 1.188 | DKO Ø1.375 - 1.125 |

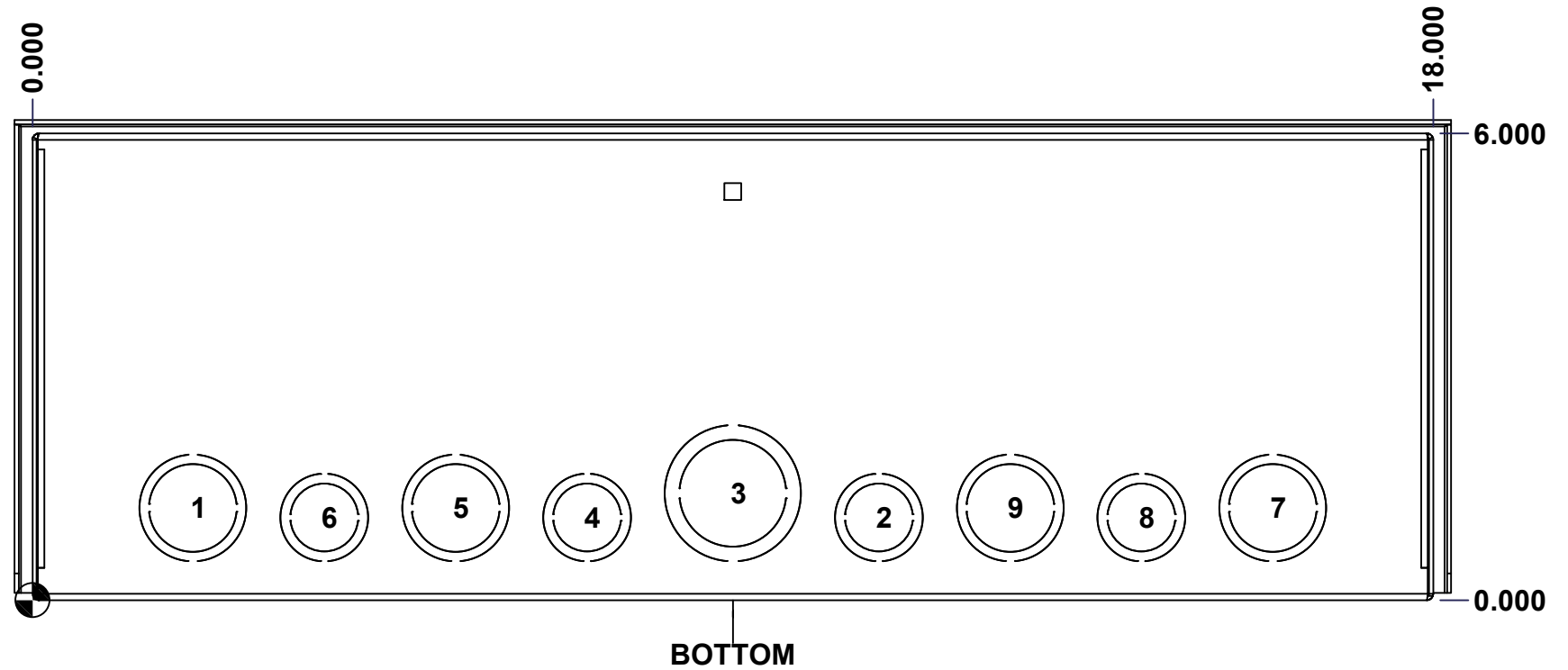

| | | |
|--|---|------------------------|
| | Description 1300 24" x 18" Body | Status (NULL) |
| | Part Number Numéro Pièce 1300241806B | Rev. 4 0 / 7 |

This drawing is confidential and must not be reproduced or used without the consent of EXM

Ce dessin est confidentiel et ne doit pas être reproduit ou utilisé sans le consentement de EXM

| No. | Revisions | Date | By/Par |
|-----|-----------|------|--------|
| | | | |
| | | | |
| | | | |
| | | | |
| | | | |

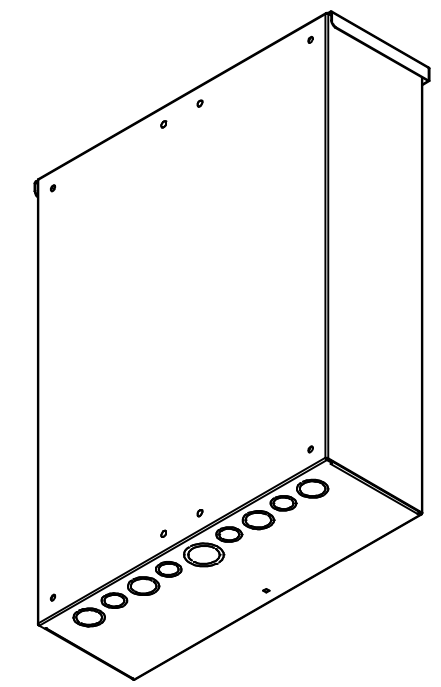

Isometric View

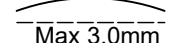
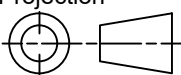

| | | |
|--|---------------------------|---|
|  Tél: (450) 979-4373 Fax: (450) 979-4626 www.exmweb.com | | Flatness Aplatissement  Max 3.0mm Projection  |
| Customer Client | Date | |
| Drawn By Dessiné Par | BoxCad: BoxCad | Date 17-Oct-19 |
| Material Matière | 16 Ga H.R.P. & O. (1.4mm) | |
| Color Couleur | Asa-61 Grey | Finish Fini Smooth |
| Description | Detail Rev. | |
| 1300 24" x 18" x 6" Body | | |
| Part Number Numéro Pièce | Rev. | 5 |
| 1300241806B | 0 | 7 |

| Qty | Part Number | Rev | Description |
|------------|---------------|-----|-------------------------------------|
| 1 | STK-P-02400S | 0 | Powder Paint (Asa-61 Grey / Smooth) |
| 1 | 1300241806B-P | 0 | 1300 24" x 18" Body Part |
| Parts List | | | |

This drawing is confidential and must not be reproduced or used without the consent of EXM

Ce dessin est confidentiel et ne doit pas être reproduit ou utilisé sans le consentement de EXM

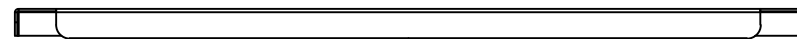

TOP

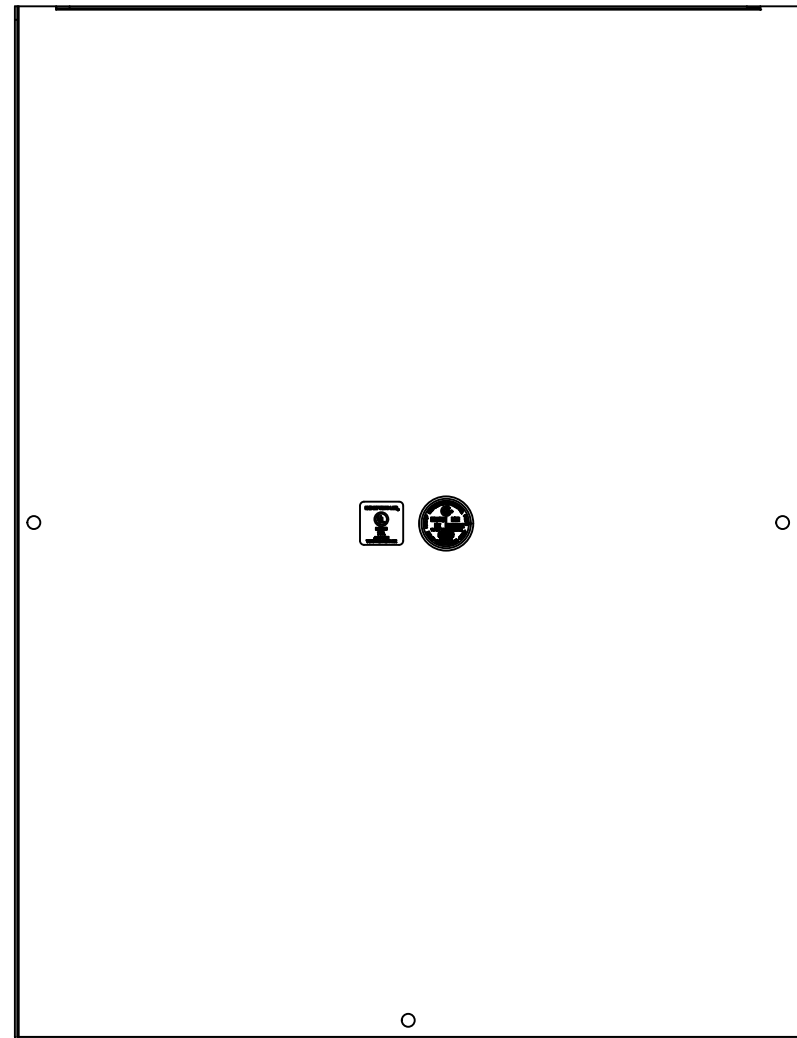

BACK



BOTTOM

0.000
0.625



LEFT

0.000

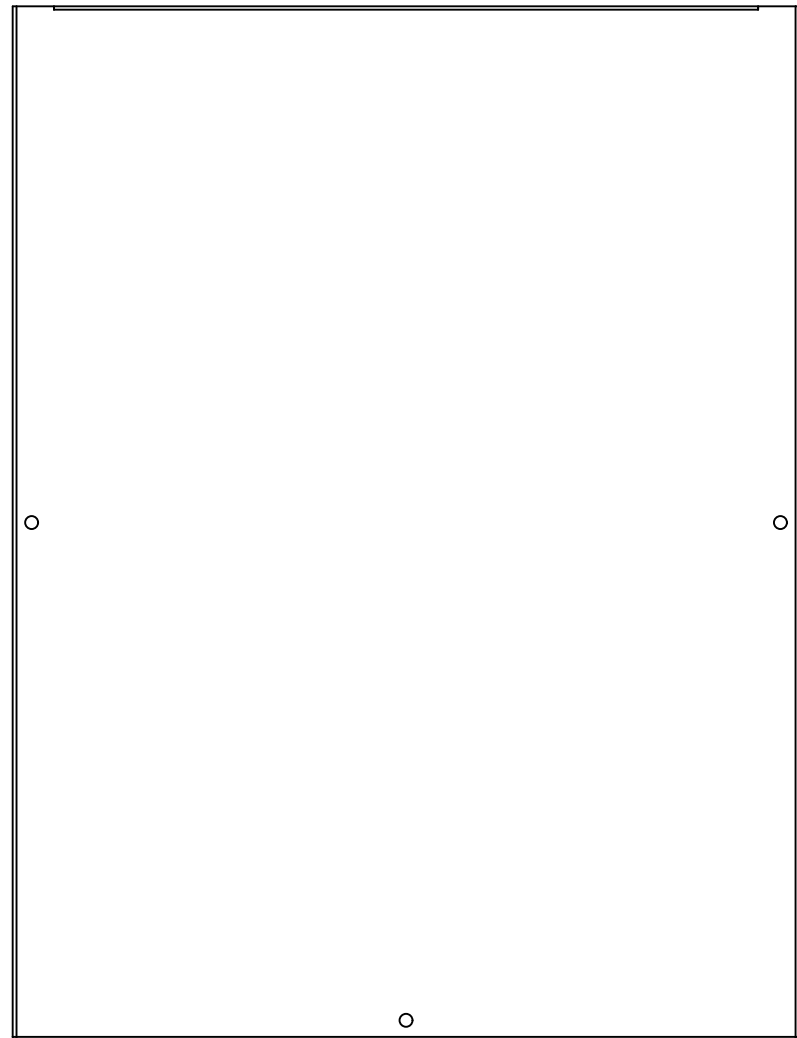

FRONT

18.250
24.000

24.000

0.000



RIGHT

| No. | Revisions | Date | By/Par |
|-----|-----------|------|--------|
| | | | |
| | | | |
| | | | |
| | | | |
| | | | |

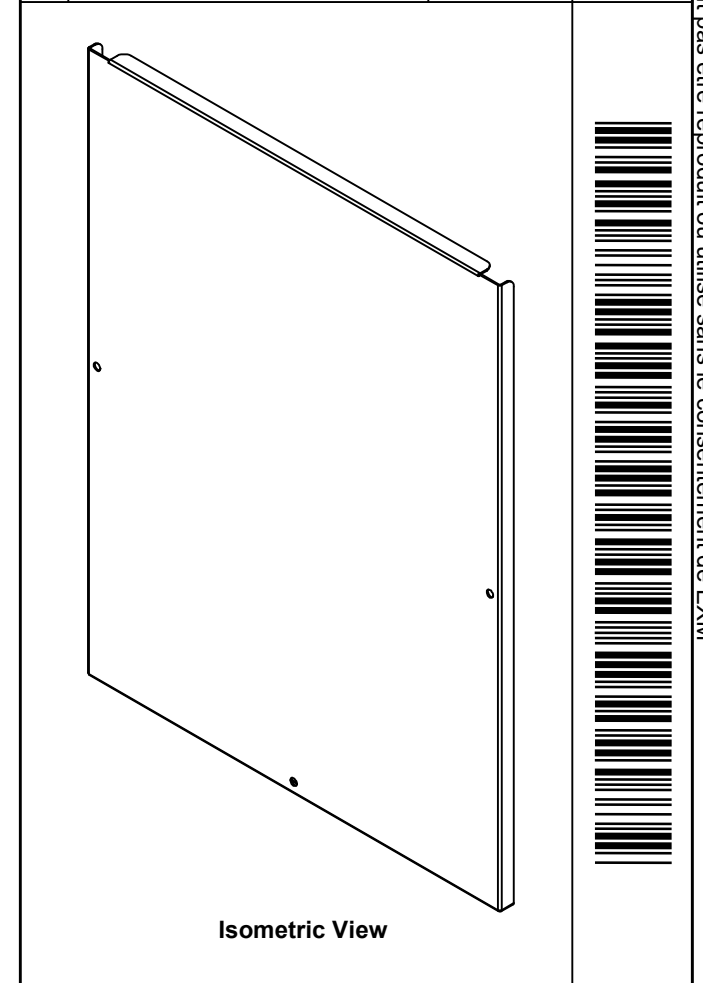

Isometric View

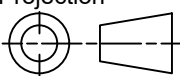

| | | |
|--|---------------------------|---|
|  Tél: (450) 979-4373 Fax: (450) 979-4626 www.exmweb.com | | Flatness Aplatissement Max 3.0mm Projection  |
| Customer Client | Date | |
| Drawn By Dessiné Par | BoxCad: BoxCad | Date 17-Oct-19 |
| Material Matière | 16 Ga H.R.P. & O. (1.4mm) | |
| Color Couleur | Asa-61 Grey | Finish Fini Smooth |
| Description | Detail Rev. | |
| 1300 24" x 18" Cover | | |
| Part Number Numéro Pièce | Rev. 0 | 6 7 |
| 1300241806C | | |

SEE BILL OF MATERIAL ON LAST PAGE

This drawing is confidential and must not be reproduced or used without the consent of EXM

Ce dessin est confidentiel et ne doit pas être reproduit ou utilisé sans le consentement de EXM

| No. | Revisions | Date | By/Par |
|-----|-----------|------|--------|
| | | | |
| | | | |
| | | | |
| | | | |
| | | | |

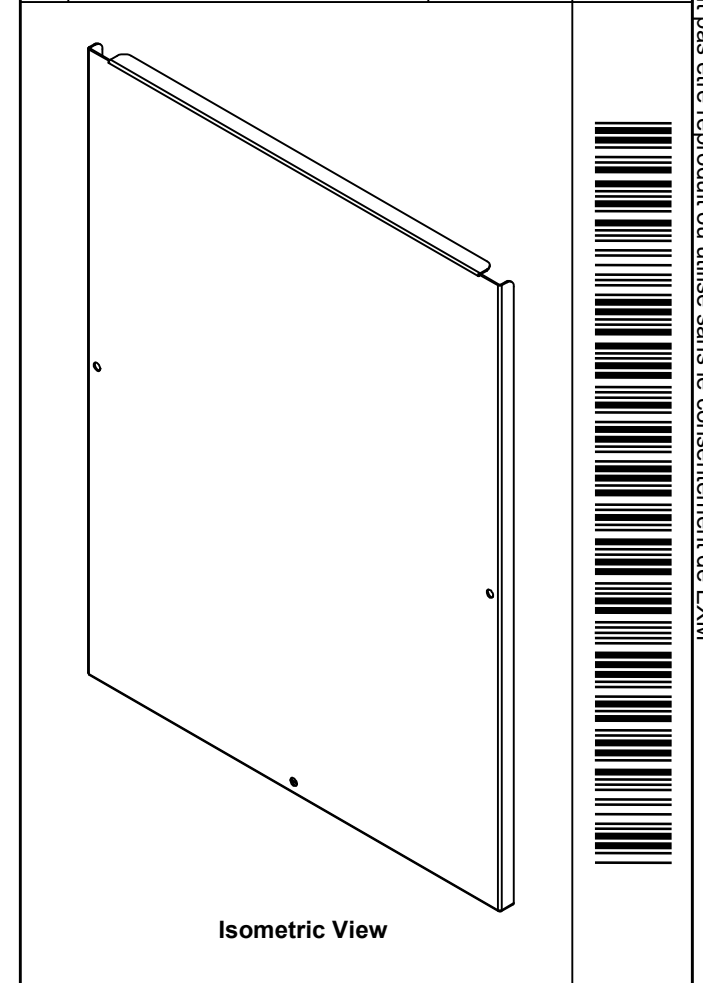

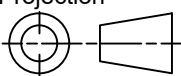
| | | |
|--|-----------------------|---|
|  Tél: (450) 979-4373 Fax: (450) 979-4626 www.exmweb.com | | Flatness Aplatissement Max 3.0mm Projection  |
| Customer Client | Date | |
| Drawn By / Dessiné Par: BoxCad: BoxCad | Date: 17-Oct-19 | |
| Material / Matière: 16 Ga H.R.P. & O. (1.4mm) | | |
| Color / Couleur: Asa-61 Grey | Finish / Fini: Smooth | |
| Description: 1300 24" x 18" Cover | | Detail Rev. |
| Part Number / Numéro Pièce: 1300241806C | Rev.: | 7 / 7 |

| Qty | Part Number | Rev | Description |
|------------|---------------|-----|-------------------------------------|
| 1 | STK-S-00950 | 1 | UL 74SL Pull-Box Sticker |
| 1 | STK-S-00800 | 2 | CSA Electrical Box Sticker |
| 1 | STK-P-02400S | 0 | Powder Paint (Asa-61 Grey / Smooth) |
| 1 | 1300241806C-P | 0 | 1300 24" x 18" Cover Part |
| Parts List | | | |