

This drawing is confidential and must not be reproduced or used without the consent of EXM

Ce dessin est confidentiel et ne doit pas être reproduit ou utilisé sans le consentement de EXM

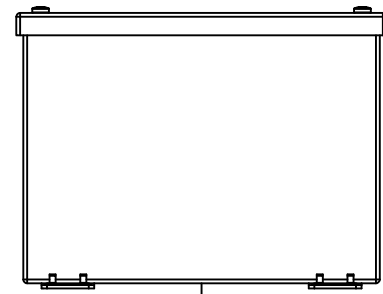

TOP

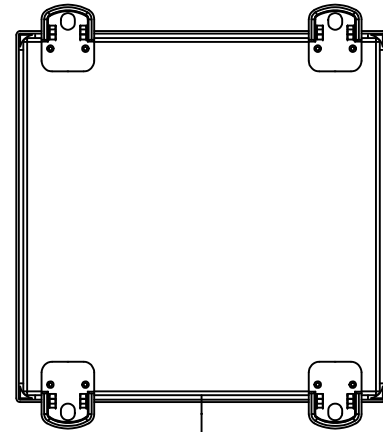

BACK

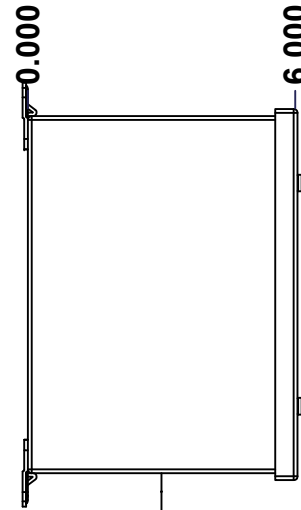

LEFT

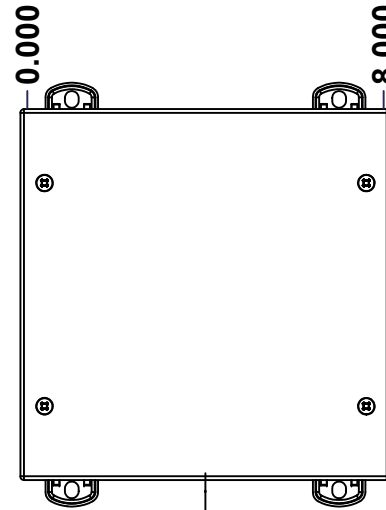

FRONT

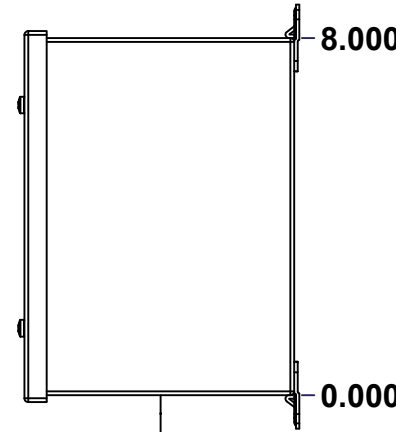

RIGHT

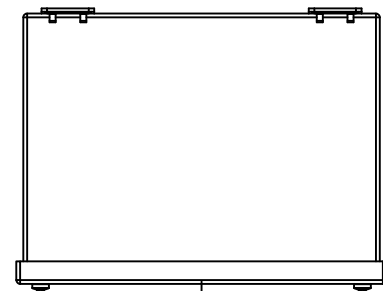

BOTTOM

| No. | Revisions | Date | By/Par |
|-----|-----------|------|--------|
|     |           |      |        |
|     |           |      |        |
|     |           |      |        |
|     |           |      |        |
|     |           |      |        |

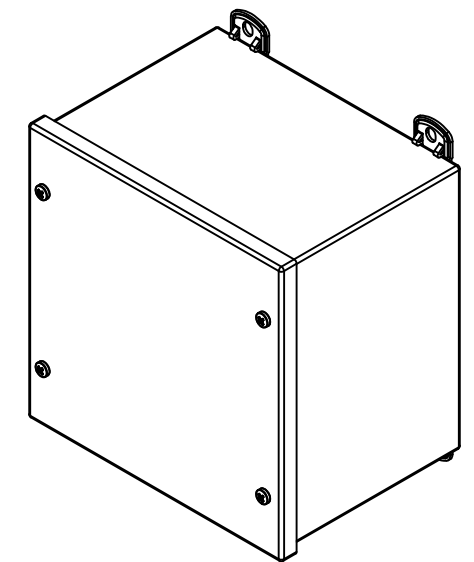

Isometric View

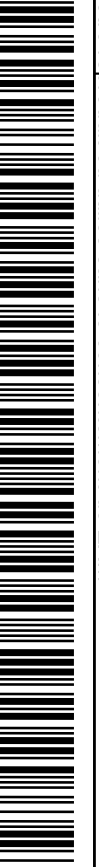

Tél: (450) 979-4373  
 Fax: (450) 979-4626  
[www.exmweb.com](http://www.exmweb.com)

Flatness  
Aplatissement  
Max 3.0mm  
Projection

Customer Client  
 Drawn By Dessiné Par BoxCad: BoxCad  
 Date 27-Jun-17

Material Matière 16 Ga H.R.P. & O. (1.4mm)

Color Couleur Asa-61 Grey  
 Finish Fini Smooth

Description 1300DWPF 8" x 8" x 6" Assembly  
 Detail Rev.

Part Number Numéro Pièce 1300DWPF080806  
 Rev. 0

SEE BILL OF MATERIAL ON LAST PAGE

|   |
|---|
| 1 |
| 2 |

This drawing is confidential and must not be reproduced or used without the consent of EXM

Ce dessin est confidentiel et ne doit pas être reproduit ou utilisé sans le consentement de EXM

| NOTE |                                    |
|------|------------------------------------|
| ITEM | DESCRIPTION                        |
| 1    | NEMA 3/3R Enclosure                |
| 2    | W/O Standard door stiffener        |
| 3    | W/O Inner panel                    |
| 4    | W/O Inner panel mounting standoffs |

| No. | Revisions | Date | By/Par |
|-----|-----------|------|--------|
|     |           |      |        |
|     |           |      |        |
|     |           |      |        |
|     |           |      |        |
|     |           |      |        |
|     |           |      |        |

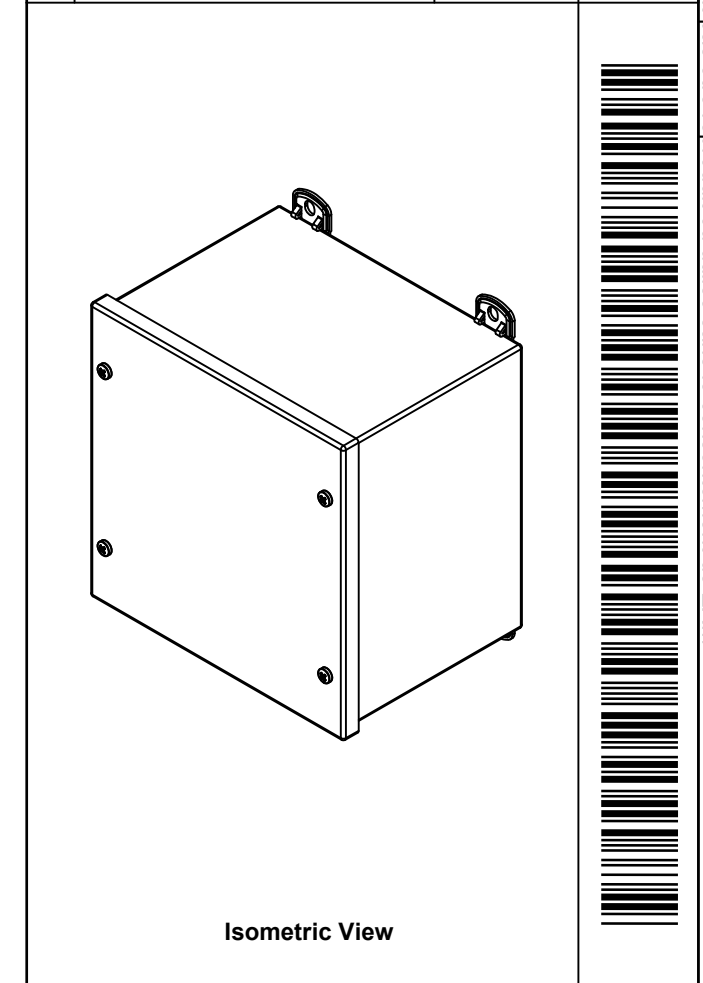

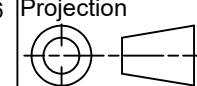
|  |                              |   |
|--|------------------------------|---|
|  Tél: (450) 979-4373<br>Fax: (450) 979-4626<br><a href="http://www.exmweb.com">www.exmweb.com</a> |                              | Flatness<br>Aplatissement<br>Max 3.0mm<br>Projection<br> |
| Customer Client  | Date                         |   |
| Drawn By / Dessiné Par: BoxCad: BoxCad   | Date: 27-Jun-17              |   |
| Material / Matière: 16 Ga H.R.P. & O. (1.4mm)  | Color / Couleur: Asa-61 Grey |   |
|  | Finish / Fini: Smooth        |   |
| Description: 1300DWPf 8" x 8" x 6" Assembly  |                              | Detail Rev.   |
| Part Number / Numéro Pièce: <b>1300DWPf080806</b>  |                              | Rev. 0  |

| PACKING              |     |   |
|----------------------|-----|---|
| ITEM                 | QTY | DESCRIPTION                             |
| Thermal plastic film | 1   | Use with Packing Tunnel Wrapper Machine |
| Packaging label      | 1   | White label with product number         |

| Qty        | Part Number     | Rev | Description                |
|------------|-----------------|-----|----------------------------|
| 1          | STK-K-11400     | 1   | 1300 DWPf Accessory Kit    |
| 1          | 1300DWPf080806C | 0   | 1300DWPf 8" x 8" Cover     |
| 1          | 1300DWPf080806B | 0   | 1300DWPf 8" x 8" x 6" Body |
| Parts List |                 |     |                            |

This drawing is confidential and must not be reproduced or used without the consent of EXM

Ce dessin est confidentiel et ne doit pas être reproduit ou utilisé sans le consentement de EXM

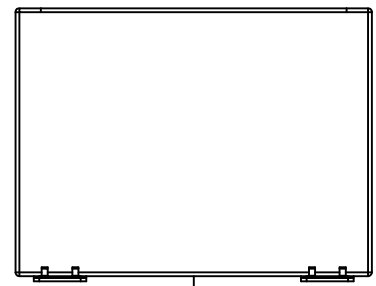

TOP

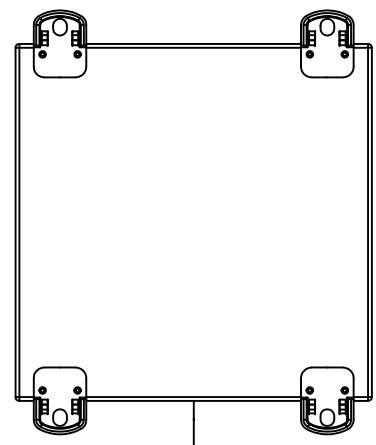

BACK

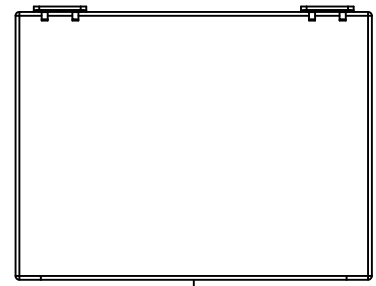

BOTTOM

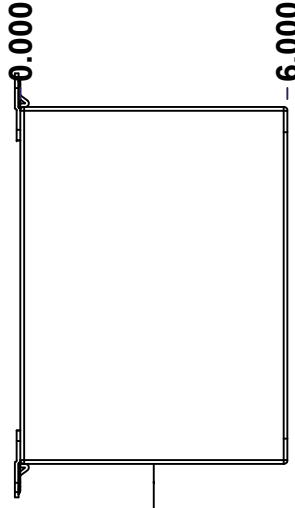

LEFT

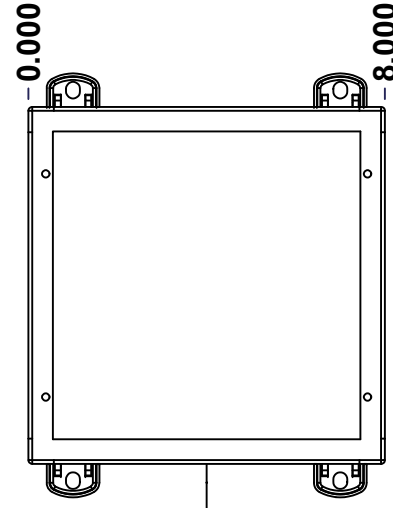

FRONT

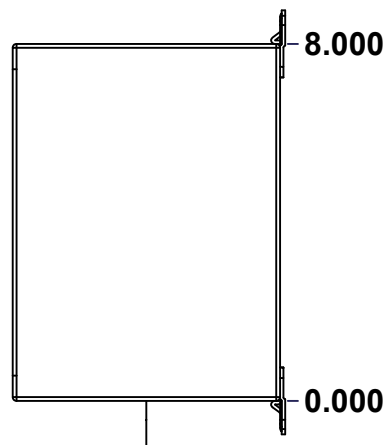

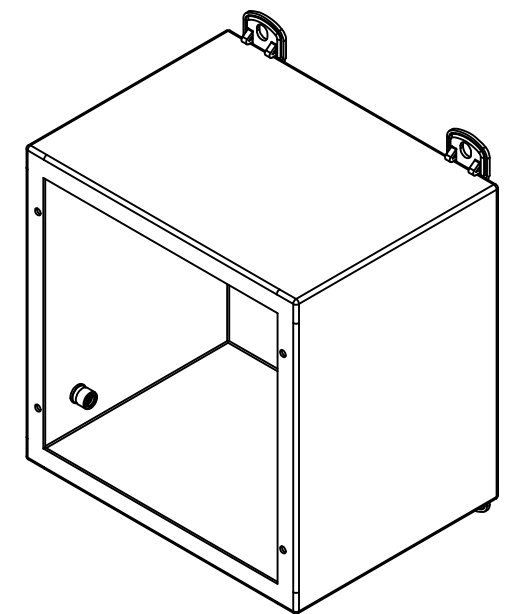

RIGHT

| No. | Revisions | Date | By/Par |
|-----|-----------|------|--------|
|     |           |      |        |
|     |           |      |        |
|     |           |      |        |
|     |           |      |        |

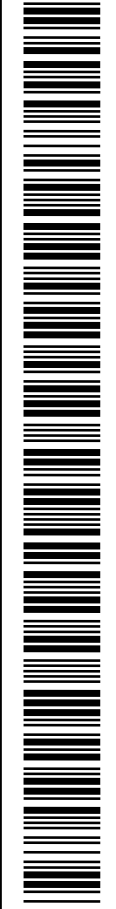

Isometric View

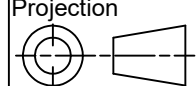

|  |                           |   |
|--|---------------------------|---|
|  Tél: (450) 979-4373<br>Fax: (450) 979-4626<br><a href="http://www.exmweb.com">www.exmweb.com</a> |                           | Flatness<br>Aplatissement<br>Max 3.0mm<br>Projection<br> |
| Customer<br>Client   | Date                      |   |
| Drawn By<br>Dessiné Par  | BoxCad: BoxCad            | Date 27-Jun-17  |
| Material<br>Matière  | 16 Ga H.R.P. & O. (1.4mm) |   |
| Color<br>Couleur   | Asa-61 Grey               | Finish<br>Fini Smooth   |
| Description<br>1300DWPF 8" x 8" x 6" Body  |                           | Detail Rev.   |
| Part Number<br>Numéro Pièce  | 1300DWPF080806B           | Rev.<br>0   |

SEE BILL OF MATERIAL ON LAST PAGE

This drawing is confidential and must not be reproduced or used without the consent of EXM

Ce dessin est confidentiel et ne doit pas être reproduit ou utilisé sans le consentement de EXM

| <b>STANDARD FEATURES ARE NOT LISTED IN THIS HOLE TABLE</b> |       |       |                             |
|--|-------|-------|-----------------------------|
| <b>HOLE TABLE - LEFT VIEW (CUSTOM FEATURE ONLY)</b>        |       |       |                             |
| CUT-OUT  | XDIM  | YDIM  | DESCRIPTION                 |
| 1  | 4.500 | 0.964 | STANDOFF M6 x 10mm (Inside) |

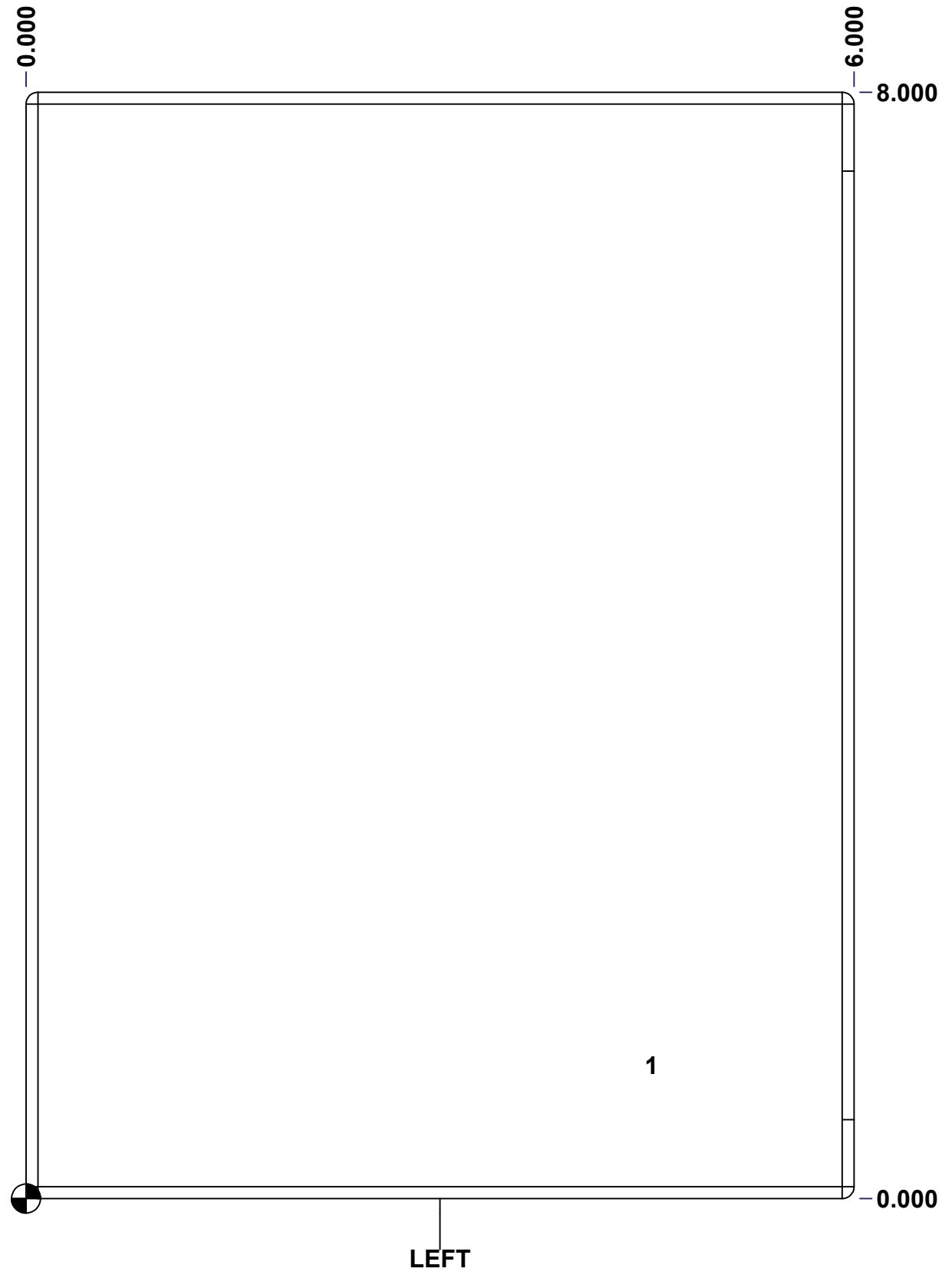



|  |                             |          |
|--|-----------------------------|----------|
|  | Description                 | Status   |
|  | 1300DWPF 8" x 8" x 6" Body  | (NULL)   |
|  | Part Number<br>Numéro Pièce | Rev.     |
|  | <b>1300DWPF080806B</b>      | <b>0</b> |
|  |                             | 5        |
|  |                             | 7        |

This drawing is confidential and must not be reproduced or used without the consent of EXM

Ce dessin est confidentiel et ne doit pas être reproduit ou utilisé sans le consentement de EXM

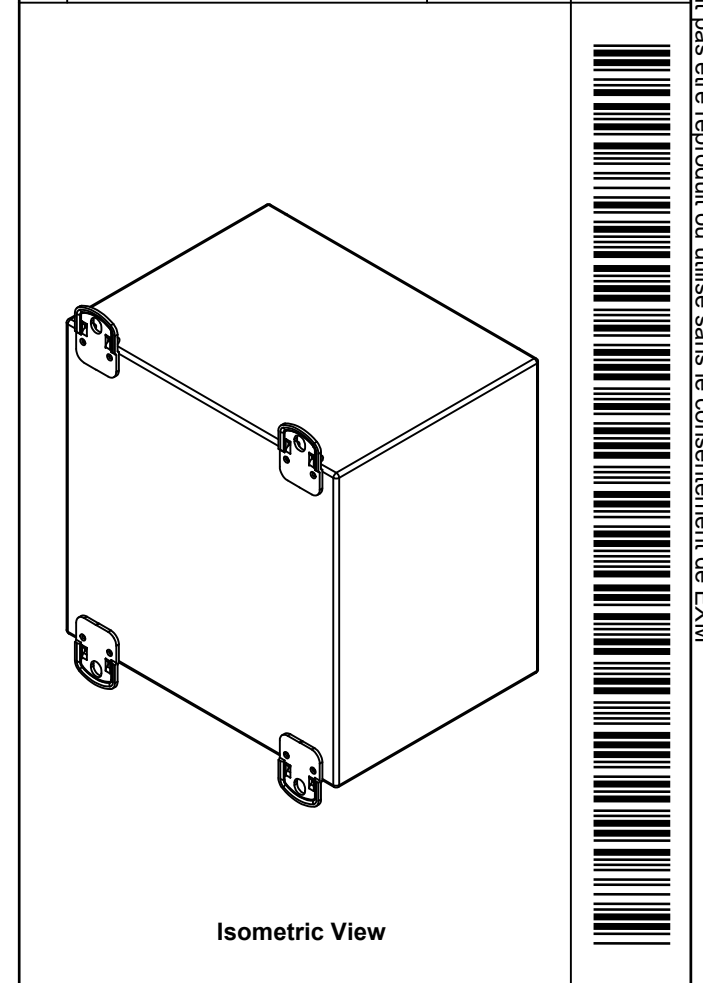
| No. | Revisions | Date | By/Par |
|-----|-----------|------|--------|
|     |           |      |        |
|     |           |      |        |
|     |           |      |        |
|     |           |      |        |
|     |           |      |        |

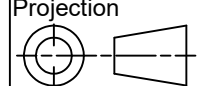

|  |                           |   |
|--|---------------------------|---|
|  Tél: (450) 979-4373<br>Fax: (450) 979-4626<br><a href="http://www.exmweb.com">www.exmweb.com</a> |                           | Flatness<br>Aplatissement<br>Max 3.0mm<br>Projection<br> |
| Customer Client  | Date                      |   |
| Drawn By<br>Dessiné Par  | BoxCad: BoxCad            | Date 27-Jun-17  |
| Material<br>Matière  | 16 Ga H.R.P. & O. (1.4mm) |   |
| Color<br>Couleur   | Asa-61 Grey               | Finish<br>Fini Smooth   |
| Description  |                           | Detail Rev.   |
| 1300DWPF 8" x 8" x 6" Body   |                           |   |
| Part Number<br>Numéro Pièce  | <b>1300DWPF080806B</b>    | Rev.<br><b>0</b>  |

| Qty        | Part_Number       | Rev | Description                         |
|------------|-------------------|-----|-------------------------------------|
| 1          | STK-Q-08350       | 5   | Standoff M6 x 10mm                  |
| 4          | STK-Q-71305       | 3   | 5412 ESMCH Stamped Mounting Foot    |
| 1          | 1300DWPF080806B-P | 0   | 1300DWPF 8" x 8" x 6" Body Part     |
| 1          | STK-P-02400S      | 0   | Powder Paint (Asa-61 Grey / Smooth) |
| Parts List |                   |     |                                     |

This drawing is confidential and must not be reproduced or used without the consent of EXM

Ce dessin est confidentiel et ne doit pas être reproduit ou utilisé sans le consentement de EXM

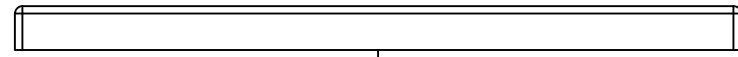

TOP

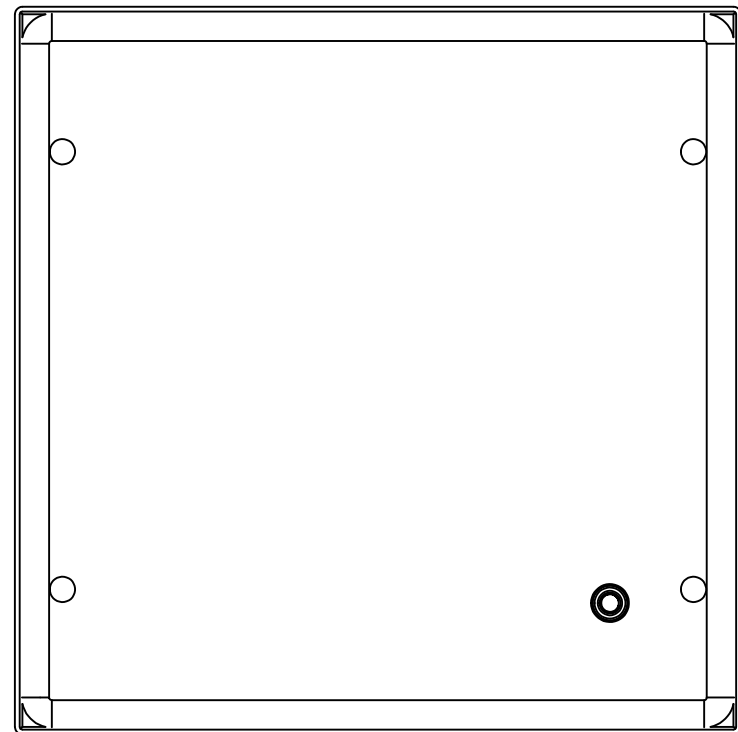

BACK

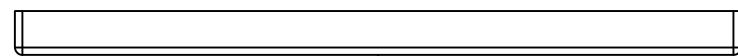

BOTTOM

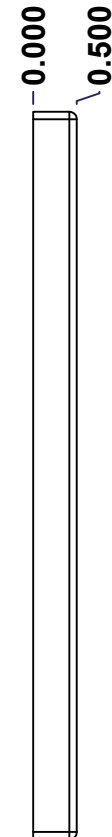

LEFT

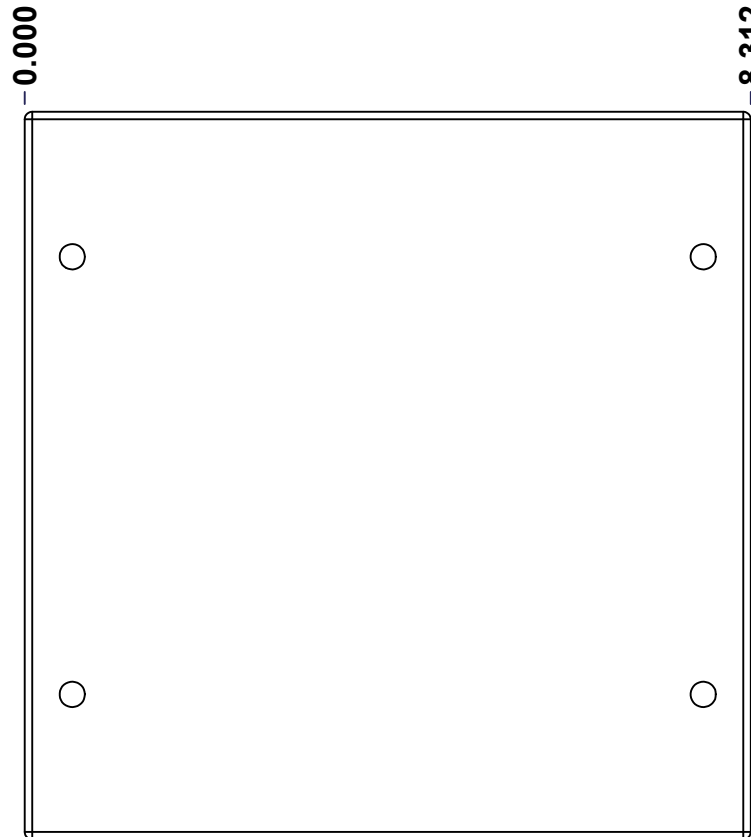

FRONT

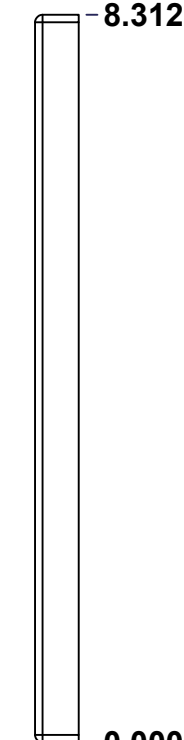

RIGHT

| No. | Revisions | Date | By/Par |
|-----|-----------|------|--------|
|     |           |      |        |
|     |           |      |        |
|     |           |      |        |
|     |           |      |        |

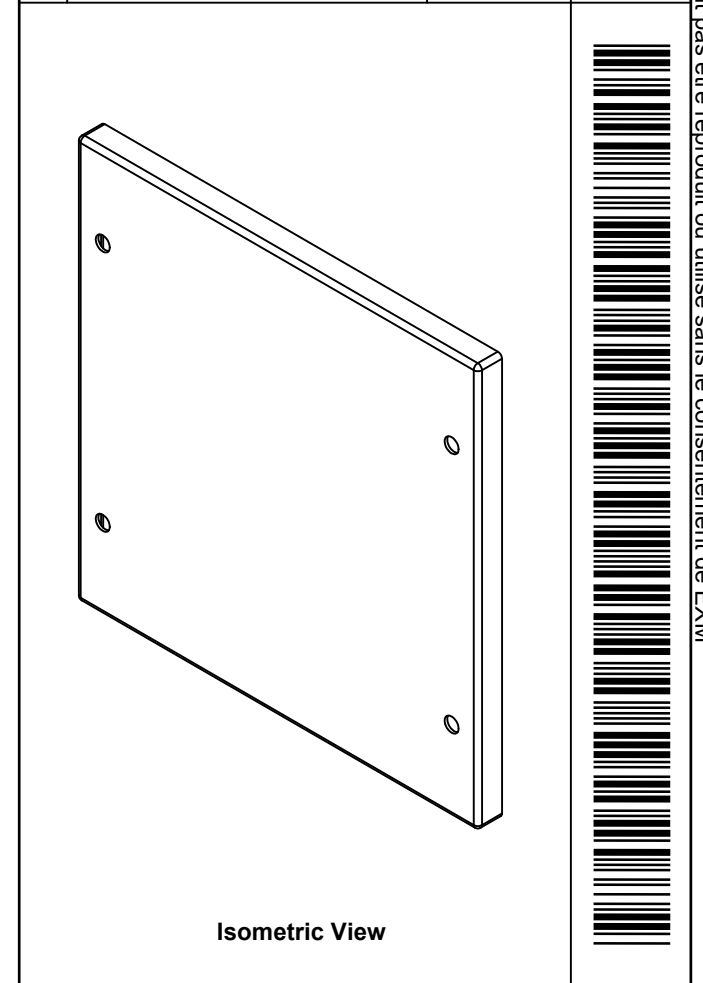

Isometric View

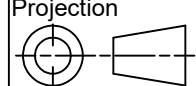

|  |  |   |             |
|--|--|---|-------------|
|  Tél: (450) 979-4373<br>Fax: (450) 979-4626<br><a href="http://www.exmweb.com">www.exmweb.com</a> |  | Flatness<br>Aplatissement<br>Max 3.0mm<br>Projection<br> |             |
| Customer Client  |  | Date  |             |
| Drawn By / Dessiné Par: BoxCad: BoxCad   |  | Date: 27-Jun-17   |             |
| Material / Matière: 16 Ga H.R.P. & O. (1.4mm)  |  |   |             |
| Color / Couleur: Asa-61 Grey   |  | Finish / Fini: Smooth   |             |
| Description: 1300DWPf 8" x 8" Cover  |  |   | Detail Rev. |
| Part Number / Numéro Pièce: 1300DWPf080806C  |  | Rev. 0  | 1 / 3       |

SEE BILL OF MATERIAL ON LAST PAGE

This drawing is confidential and must not be reproduced or used without the consent of EXM

Ce dessin est confidentiel et ne doit pas être reproduit ou utilisé sans le consentement de EXM

| <b>STANDARD FEATURES ARE NOT LISTED IN THIS HOLE TABLE</b> |       |       |                             |
|--|-------|-------|-----------------------------|
| <b>HOLE TABLE - FRONT VIEW (CUSTOM FEATURE ONLY)</b>       |       |       |                             |
| CUT-OUT  | XDIM  | YDIM  | DESCRIPTION                 |
| 1  | 1.500 | 1.500 | STANDOFF M6 x 10mm (Inside) |

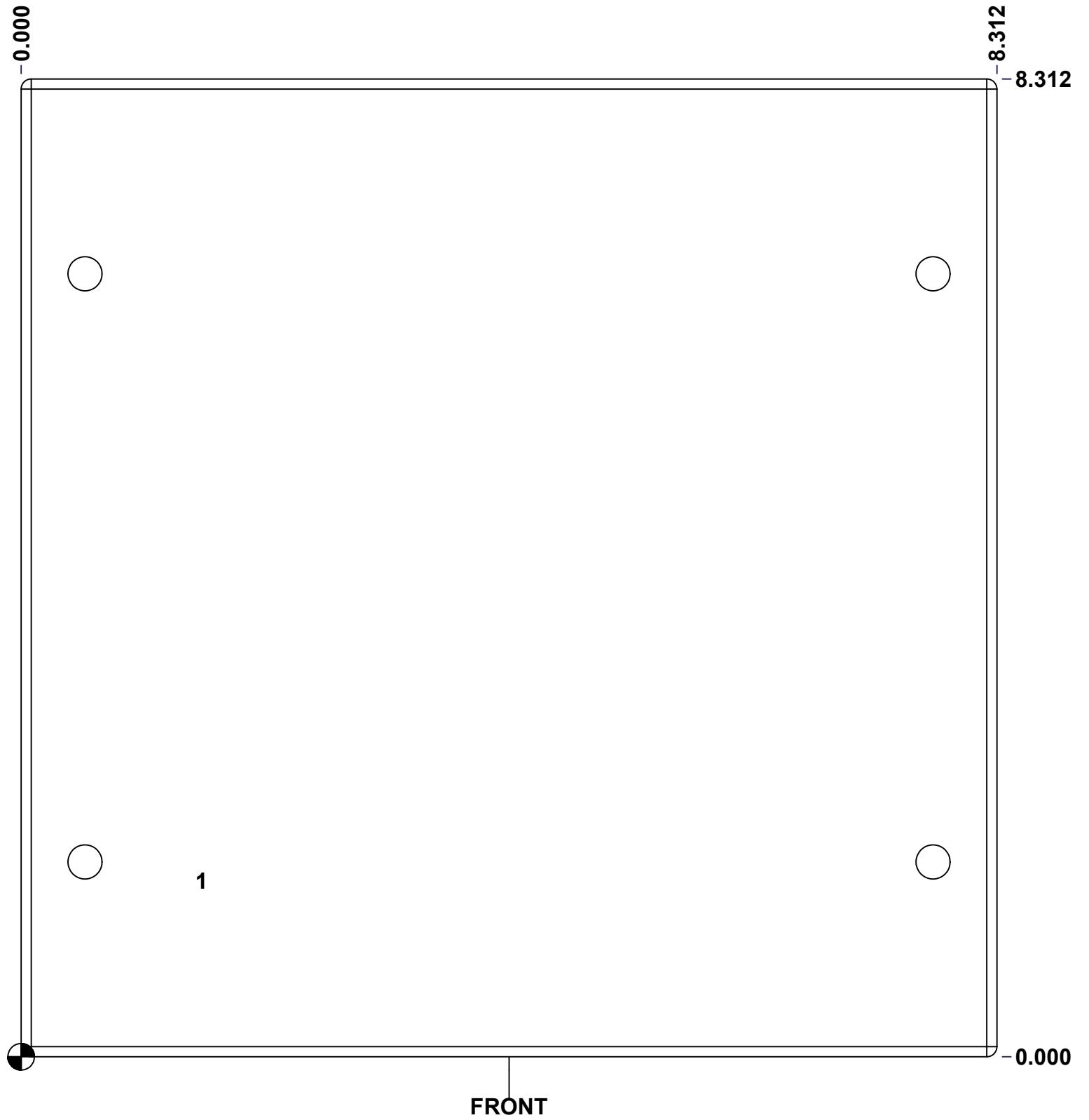

FRONT

|  |                             |          |     |
|--|-----------------------------|----------|-----|
|  | Description                 | Status   |     |
|  | 1300DWPF 8" x 8" Cover      | (NULL)   |     |
|  | Part Number<br>Numéro Pièce | Rev.     |     |
|  | <b>1300DWPF080806C</b>      | <b>0</b> | 2/3 |

This drawing is confidential and must not be reproduced or used without the consent of EXM

Ce dessin est confidentiel et ne doit pas être reproduit ou utilisé sans le consentement de EXM

| No. | Revisions | Date | By/Par |
|-----|-----------|------|--------|
|     |           |      |        |
|     |           |      |        |
|     |           |      |        |
|     |           |      |        |
|     |           |      |        |

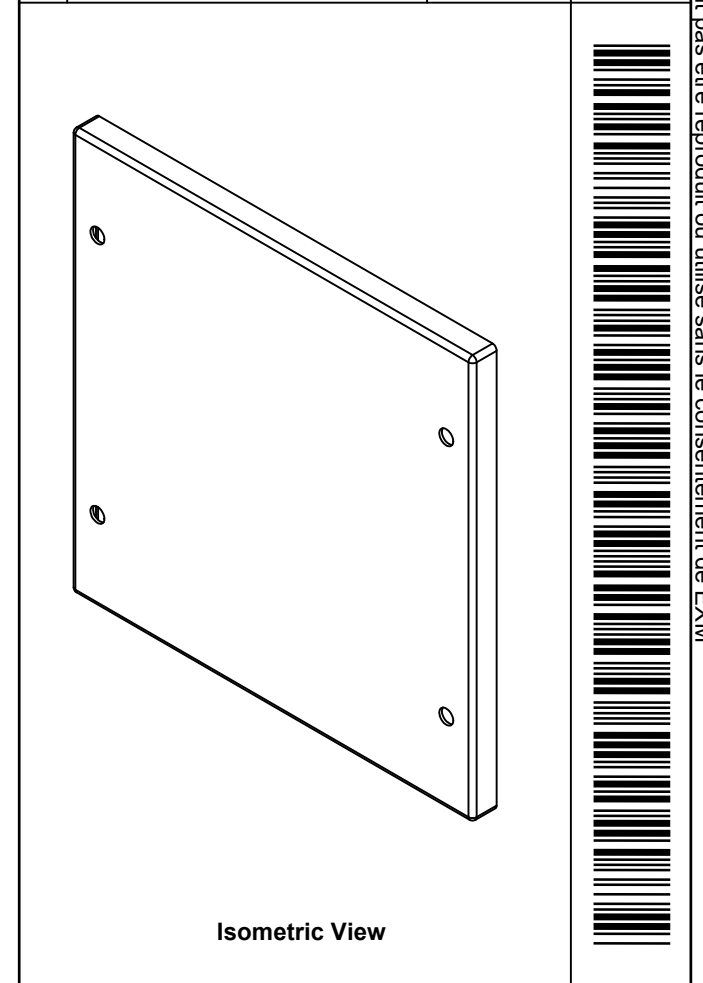

|  |  |                           |             |
|--|--|---------------------------|-------------|
|  Tél: (450) 979-4373<br>Fax: (450) 979-4626<br><a href="http://www.exmweb.com">www.exmweb.com</a> |  | Flatness<br>Aplatissement |             |
|  |  | Max 3.0mm                 |             |
| Customer<br>Client   |  | Date                      |             |
| Drawn By<br>Dessiné Par  |  | Date                      |             |
| BoxCad: BoxCad   |  | 27-Jun-17                 |             |
| Material<br>Matière  |  |                           |             |
| 16 Ga H.R.P. & O. (1.4mm)  |  |                           |             |
| Color<br>Couleur   |  | Finish<br>Fini            |             |
| Asa-61 Grey  |  | Smooth                    |             |
| Description  |  |                           | Detail Rev. |
| 1300DWPf 8" x 8" Cover   |  |                           |             |
| Part Number<br>Numéro Pièce  |  | Rev.                      | 3           |
| <b>1300DWPf080806C</b>   |  | <b>0</b>                  | <b>3</b>    |

| Qty        | Part Number       | Rev | Description                         |
|------------|-------------------|-----|-------------------------------------|
| 1          | STK-Q-08350       | 5   | Standoff M6 x 10mm                  |
| 1          | STK-P-02400S      | 0   | Powder Paint (Asa-61 Grey / Smooth) |
| 1          | 1300DWPf080806C-P | 0   | 1300DWPf 8" x 8" Cover Part         |
| 1          | 1300DWPf080806G   | 0   | 1300DWPf 8" x 8" Cover Gasket       |
| Parts List |                   |     |                                     |