

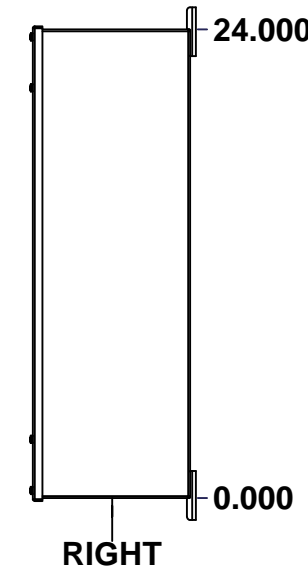

This drawing is confidential and must not be reproduced or used without the consent of EXM

Ce dessin est confidentiel et ne doit pas être reproduit ou utilisé sans le consentement de EXM

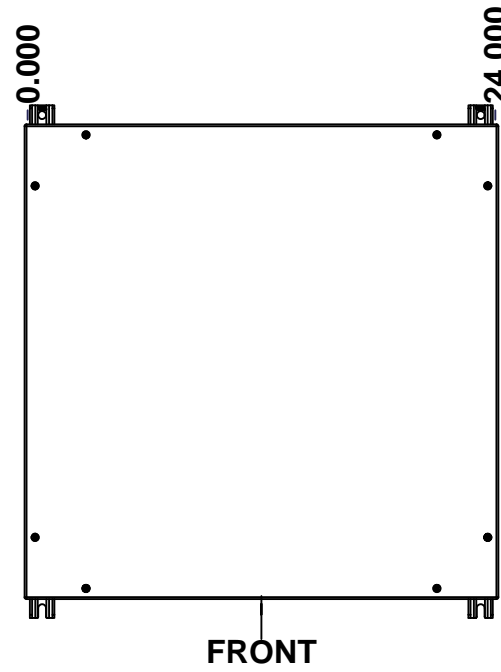
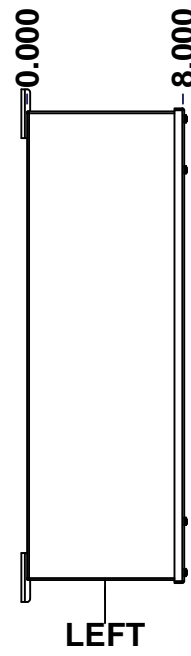
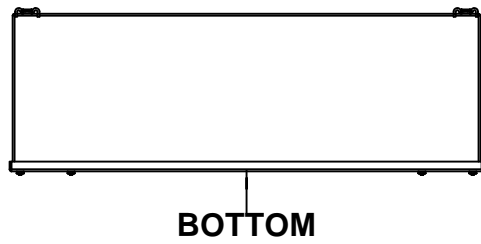
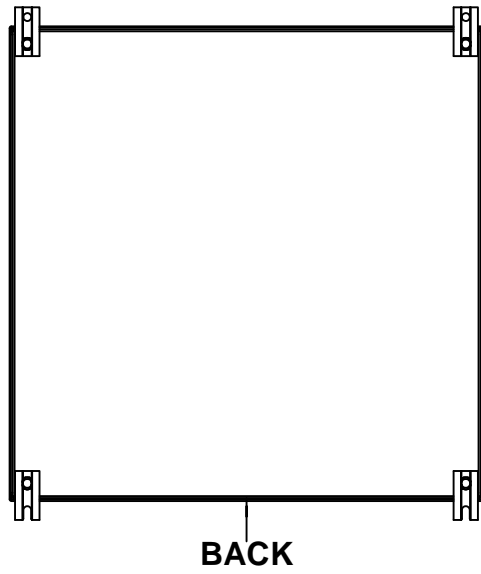
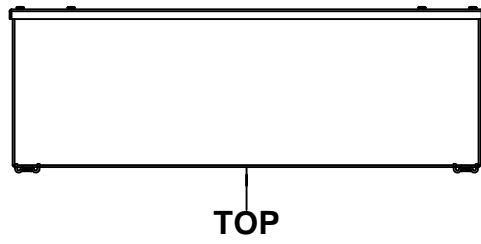
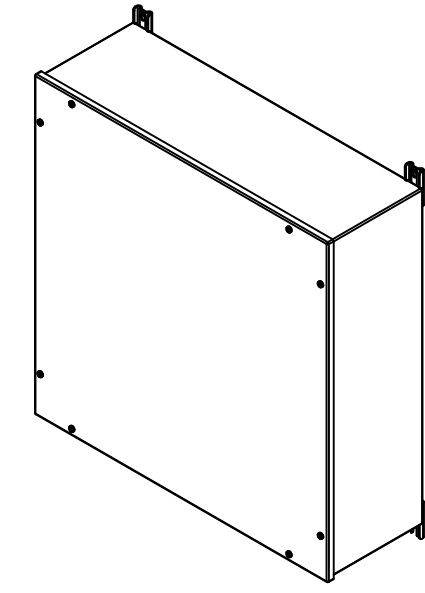

No.	Revisions	Date	By/Par

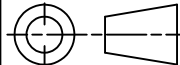

 Tél: (450) 979-4373 Fax: (450) 979-4626 www.exmweb.com		Flatness Aplatissement
		Max 3.0mm
Projection 		
Customer Client	Date	
Drawn By Dessiné Par	BoxCad: BoxCad	Date 27-Jun-17
Material Matière	14 Ga H.R.P. & O. (1.7mm)	
Color Couleur	Asa-61 Grey	Finish Fini Smooth
Description	Detail Rev.	
1300DWPf 24" x 24" x 8" Assembly		
Part Number Numéro Pièce	Rev.	1 2
1300DWPf242408		0

SEE BILL OF MATERIAL ON LAST PAGE

This drawing is confidential and must not be reproduced or used without the consent of EXM

Ce dessin est confidentiel et ne doit pas être reproduit ou utilisé sans le consentement de EXM

NOTE	
ITEM	DESCRIPTION
1	NEMA 3/3R Enclosure
2	W/O Standard door stiffener
3	W/O Inner panel
4	W/O Inner panel mounting standoffs
5	C/W Mounting feet 885 ESMF1 (Included in kit)

No.	Revisions	Date	By/Par

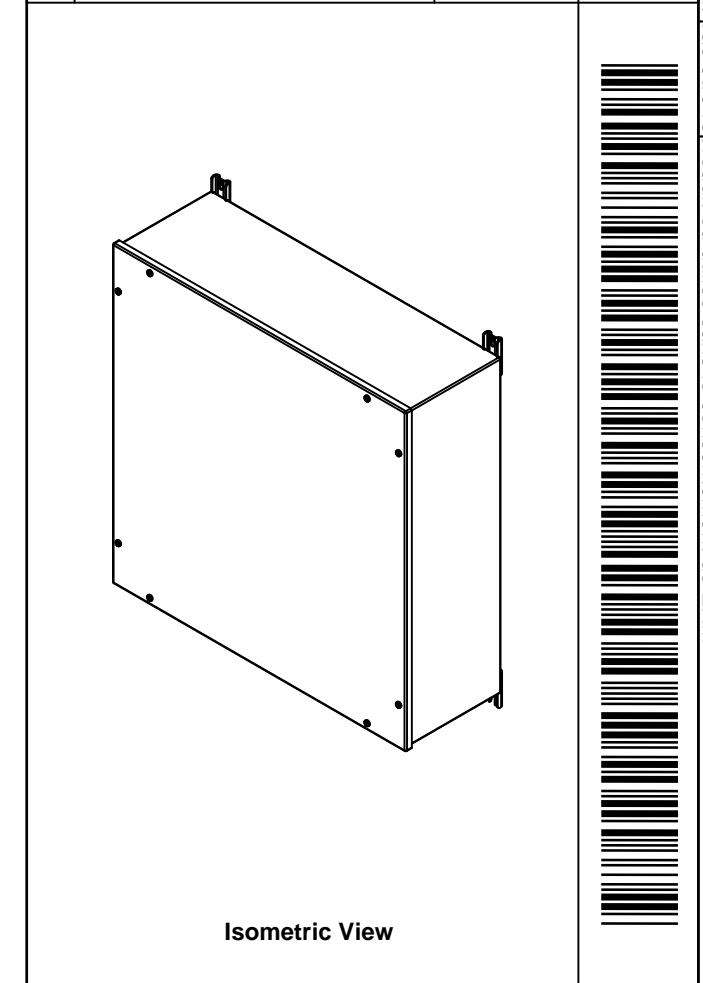

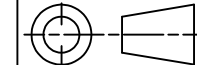
 Tél: (450) 979-4373 Fax: (450) 979-4626 www.exmweb.com		Flatness Aplatissement Max 3.0mm Projection 
Customer Client	Date	
Drawn By Dessiné Par	BoxCad: BoxCad	Date 27-Jun-17
Material Matière	14 Ga H.R.P. & O. (1.7mm)	
Color Couleur	Asa-61 Grey	Finish Fini Smooth
Description	Detail Rev.	
1300DWPF 24" x 24" x 8" Assembly		
Part Number Numéro Pièce	1300DWPF242408	Rev. 2
		0

PACKING		
ITEM	QTY	DESCRIPTION
Cardboard sleeve	2	Top and Bottom
Plastic strap - Black	2	To squeeze the 2 cardboard sleeve together
Thermal plastic film	1	Use with Packing Tunnel Wrapper Machine
Packaging label	1	White label with product number

Qty	Part Number	Rev	Description
1	885 ESMF1	0	885 ESMF1 Mounting Feet Kit
1	1300DWPF242408C	0	1300DWPF 24" x 24" Cover
1	1300DWPF242408B	0	1300DWPF 24" x 24" x 8" Body
2	STK-K-11400	1	1300 DWPF Accessory Kit
Parts List			

This drawing is confidential and must not be reproduced or used without the consent of EXM

Ce dessin est confidentiel et ne doit pas être reproduit ou utilisé sans le consentement de EXM



TOP

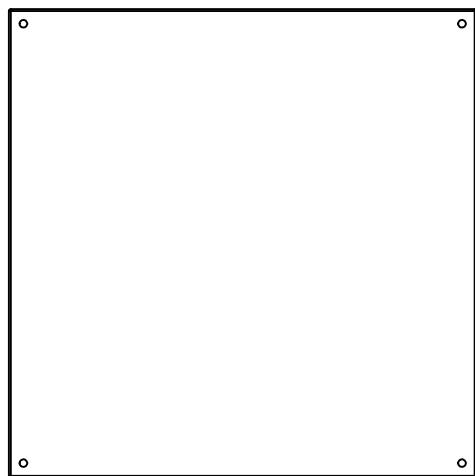

BACK



BOTTOM

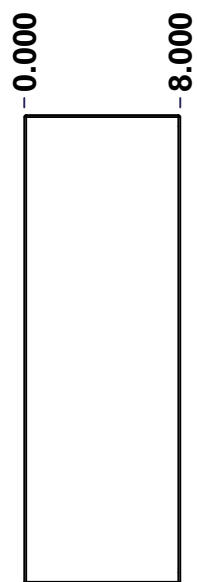

LEFT

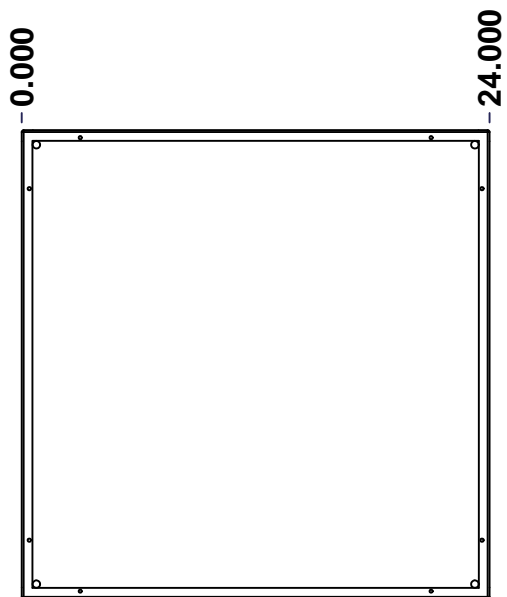

FRONT

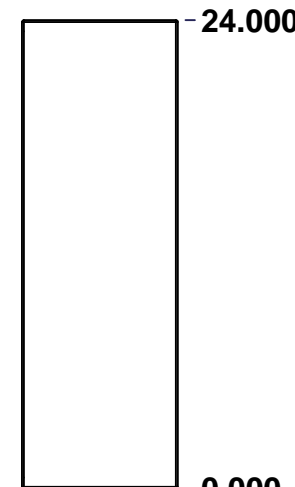

RIGHT

No.	Revisions	Date	By/Par

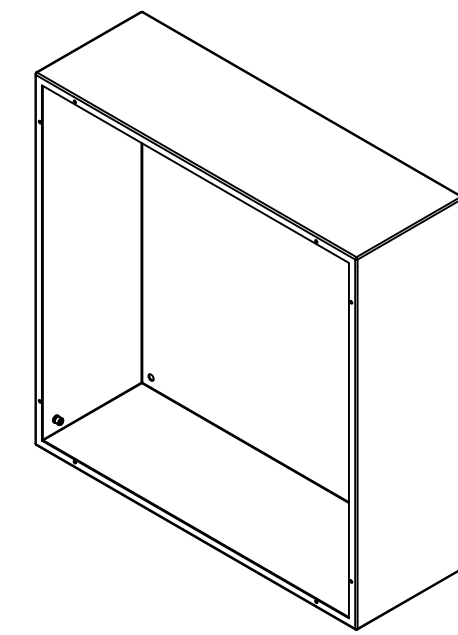

Isometric View



Tél: (450) 979-4373
 Fax: (450) 979-4626
www.exmweb.com

Flatness
Aplatissement
Max 3.0mm
Projection

Customer Client	Date
Drawn By / Dessiné Par: BoxCad: BoxCad	Date: 27-Jun-17
Material / Matière: 14 Ga H.R.P. & O. (1.7mm)	
Color / Couleur: Asa-61 Grey	Finish / Fini: Smooth
Description: 1300DWPf 24" x 24" x 8" Body	Detail Rev.
Part Number / Numéro Pièce: 1300DWPf242408B	Rev.: 0

SEE BILL OF MATERIAL ON LAST PAGE

This drawing is confidential and must not be reproduced or used without the consent of EXM

Ce dessin est confidentiel et ne doit pas être reproduit ou utilisé sans le consentement de EXM

STANDARD FEATURES ARE NOT LISTED IN THIS HOLE TABLE			
HOLE TABLE - LEFT VIEW (CUSTOM FEATURE ONLY)			
CUT-OUT	XDIM	YDIM	DESCRIPTION
1	6.500	0.964	STANDOFF M6 x 10mm (Inside)

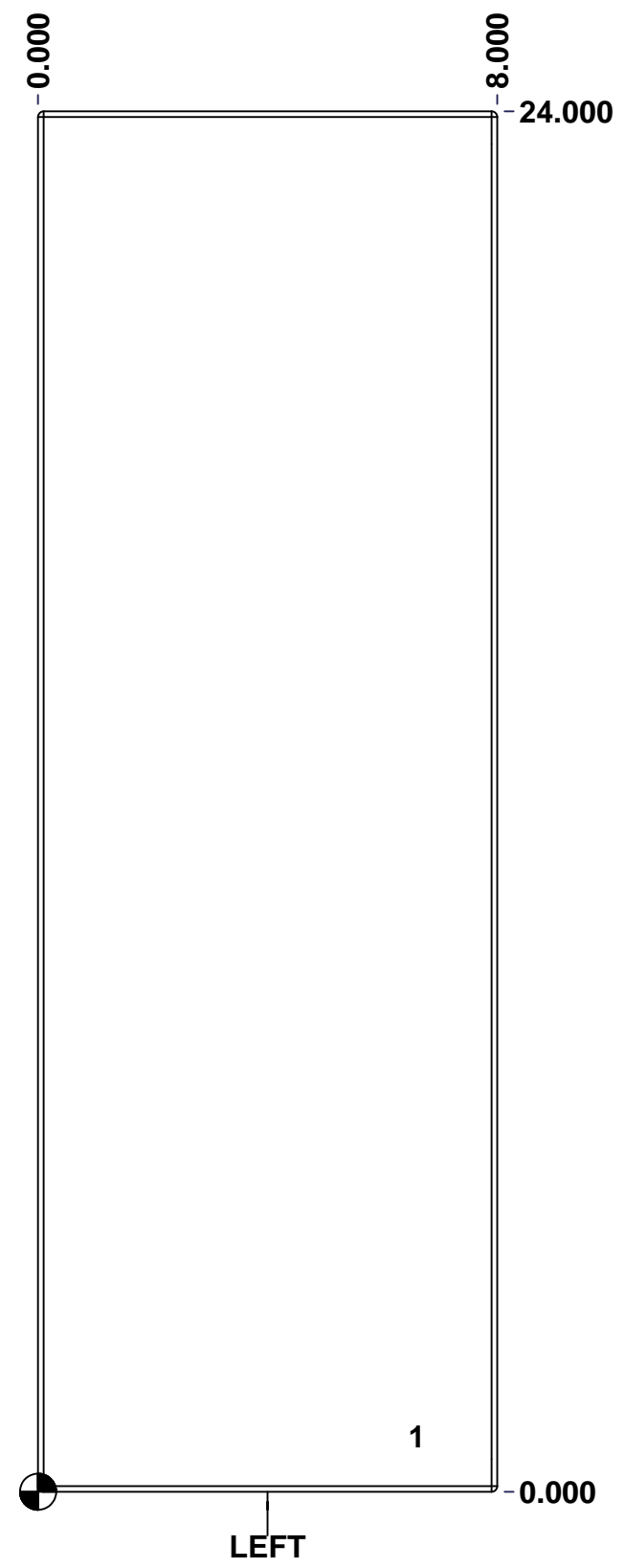



	Description	Status	
	1300DWPF 24" x 24" x 8" Body	(NULL)	
	Part Number Numéro Pièce	Rev.	5 / 7
	1300DWPF242408B	0	

This drawing is confidential and must not be reproduced or used without the consent of EXM

Ce dessin est confidentiel et ne doit pas être reproduit ou utilisé sans le consentement de EXM

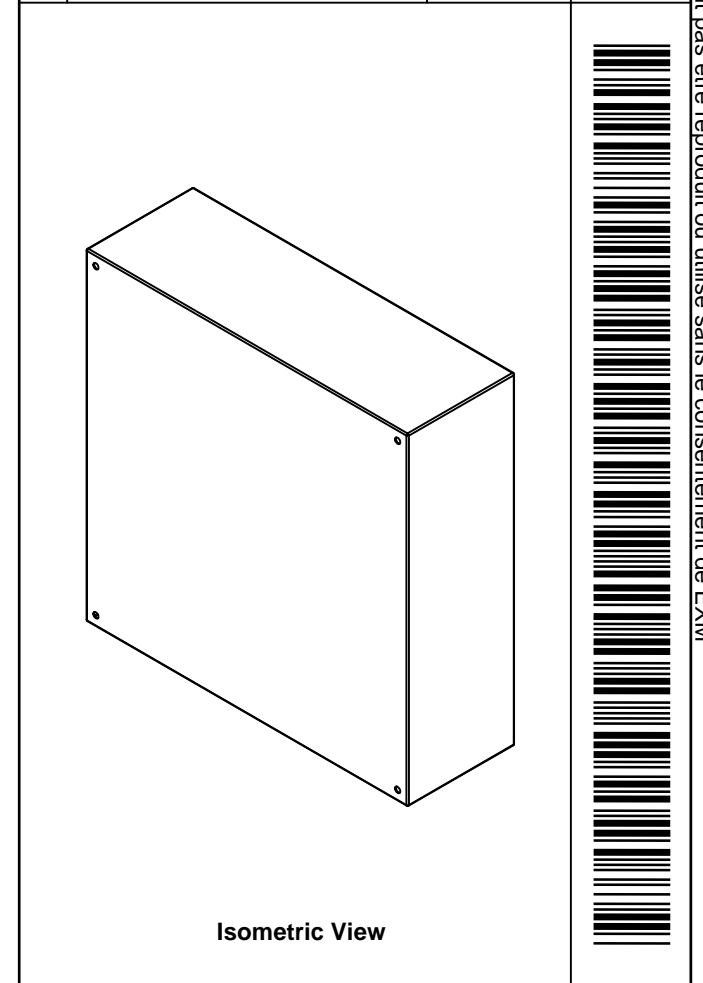
No.	Revisions	Date	By/Par

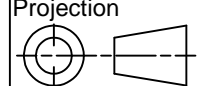

 Tél: (450) 979-4373 Fax: (450) 979-4626 www.exmweb.com		Flatness Aplatissement Max 3.0mm Projection 
Customer Client	Date	
Drawn By / Dessiné Par: BoxCad: BoxCad	Date: 27-Jun-17	
Material / Matière: 14 Ga H.R.P. & O. (1.7mm)		
Color / Couleur: Asa-61 Grey	Finish / Fini: Smooth	
Description: 1300DWPf 24" x 24" x 8" Body		Detail Rev.
Part Number / Numéro Pièce: 1300DWPf242408B		Rev. 0

Qty	Part_Number	Rev	Description
1	STK-P-02400S	0	Powder Paint (Asa-61 Grey / Smooth)
1	1300DWPf242408B-P	0	1300DWPf 24" x 24" x 8" Body Part
1	STK-Q-08350	5	Standoff M6 x 10mm
Parts List			

This drawing is confidential and must not be reproduced or used without the consent of EXM

Ce dessin est confidentiel et ne doit pas être reproduit ou utilisé sans le consentement de EXM

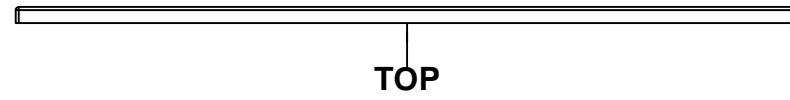

TOP

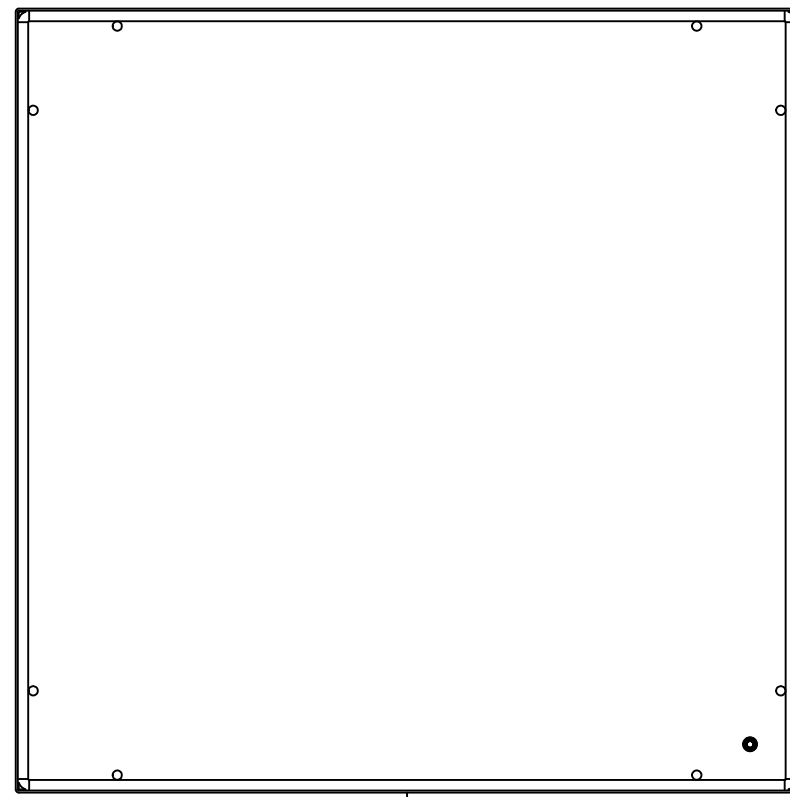

BACK

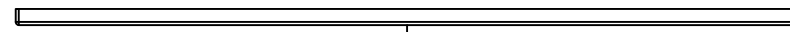

BOTTOM

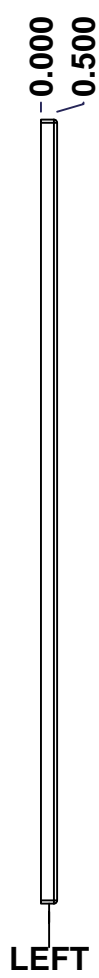

LEFT

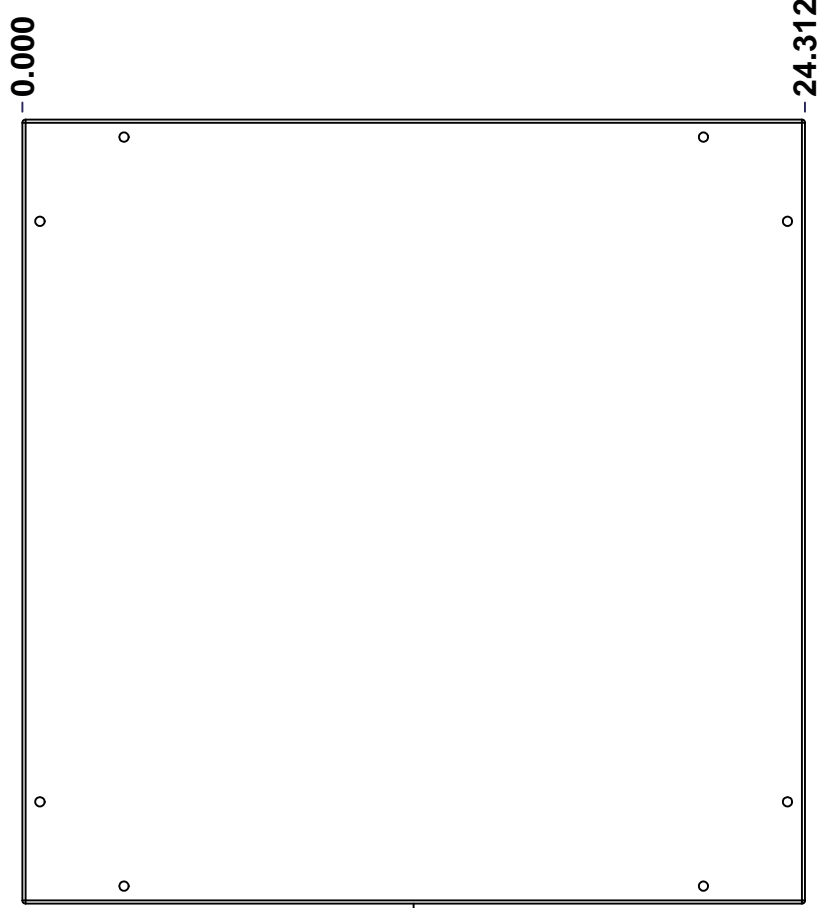

FRONT

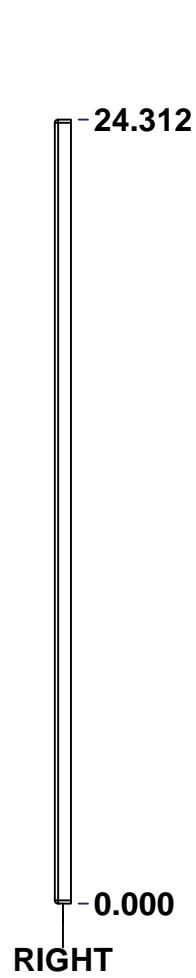

RIGHT

No.	Revisions	Date	By/Par

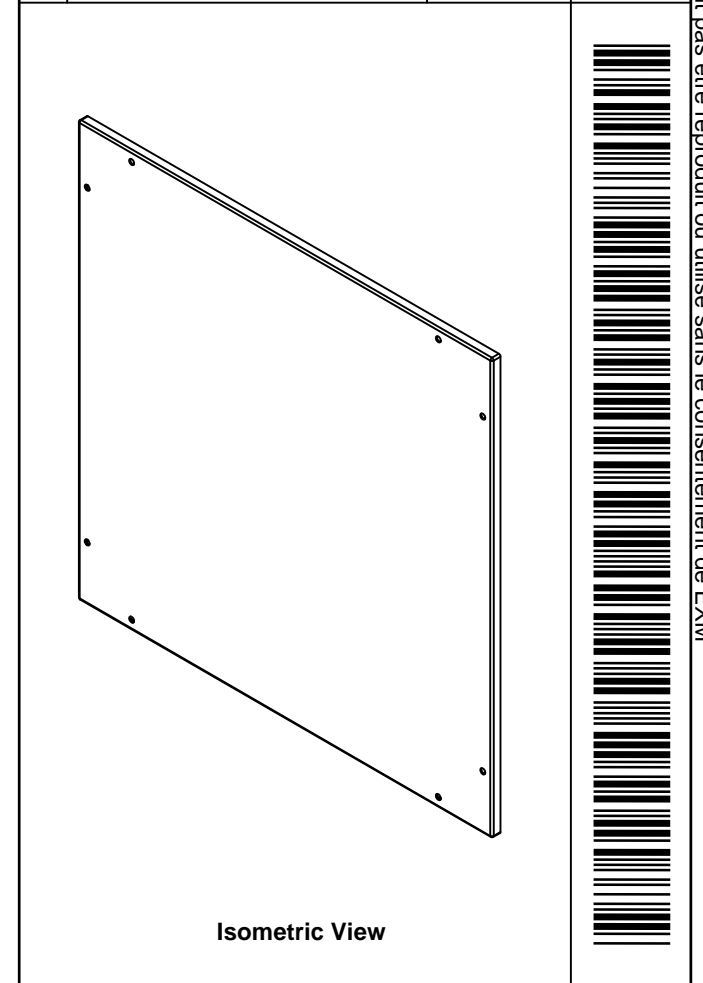

Isometric View



		Tél: (450) 979-4373 Fax: (450) 979-4626 www.exmweb.com		Flatness Aplatissement Max 3.0mm Projection 	
Customer Client			Date		
Drawn By / Dessiné Par: BoxCad: BoxCad			Date: 27-Jun-17		
Material / Matière: 14 Ga H.R.P. & O. (1.7mm)					
Color / Couleur: Asa-61 Grey		Finish / Fini: Smooth			
Description: 1300DWP24" x 24" Cover				Detail Rev.	
Part Number / Numéro Pièce: 1300DWP242408C			Rev.:	1	3

SEE BILL OF MATERIAL ON LAST PAGE

This drawing is confidential and must not be reproduced or used without the consent of EXM

Ce dessin est confidentiel et ne doit pas être reproduit ou utilisé sans le consentement de EXM

STANDARD FEATURES ARE NOT LISTED IN THIS HOLE TABLE			
HOLE TABLE - FRONT VIEW (CUSTOM FEATURE ONLY)			
CUT-OUT	XDIM	YDIM	DESCRIPTION
1	1.500	1.500	STANDOFF M6 x 10mm (Inside)

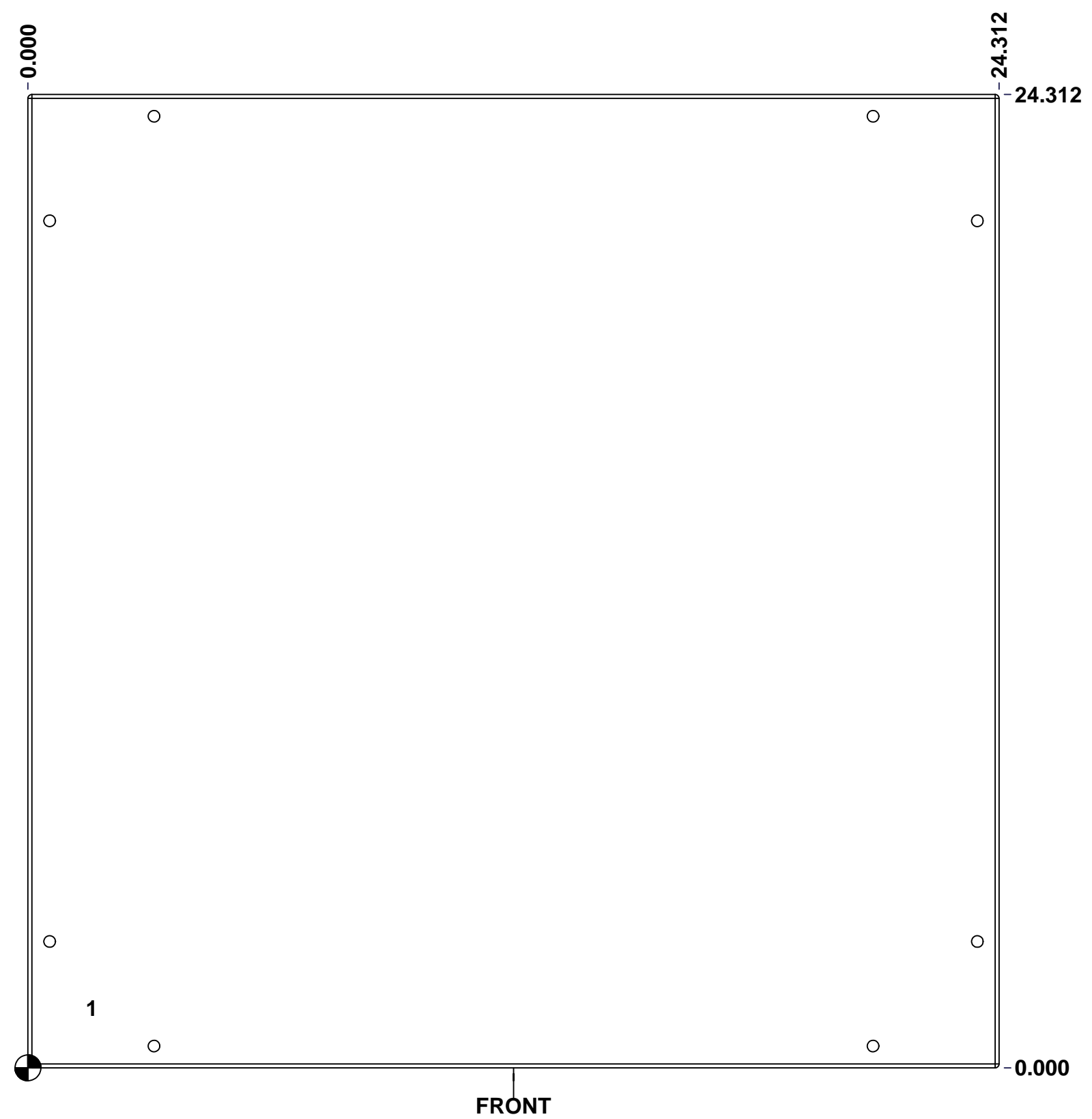

	Description	Status
	1300DWPf 24" x 24" Cover	(NULL)
	Part Number Numéro Pièce	Rev.
	1300DWPf242408C	0
		2
		3

This drawing is confidential and must not be reproduced or used without the consent of EXM

Ce dessin est confidentiel et ne doit pas être reproduit ou utilisé sans le consentement de EXM

No.	Revisions	Date	By/Par

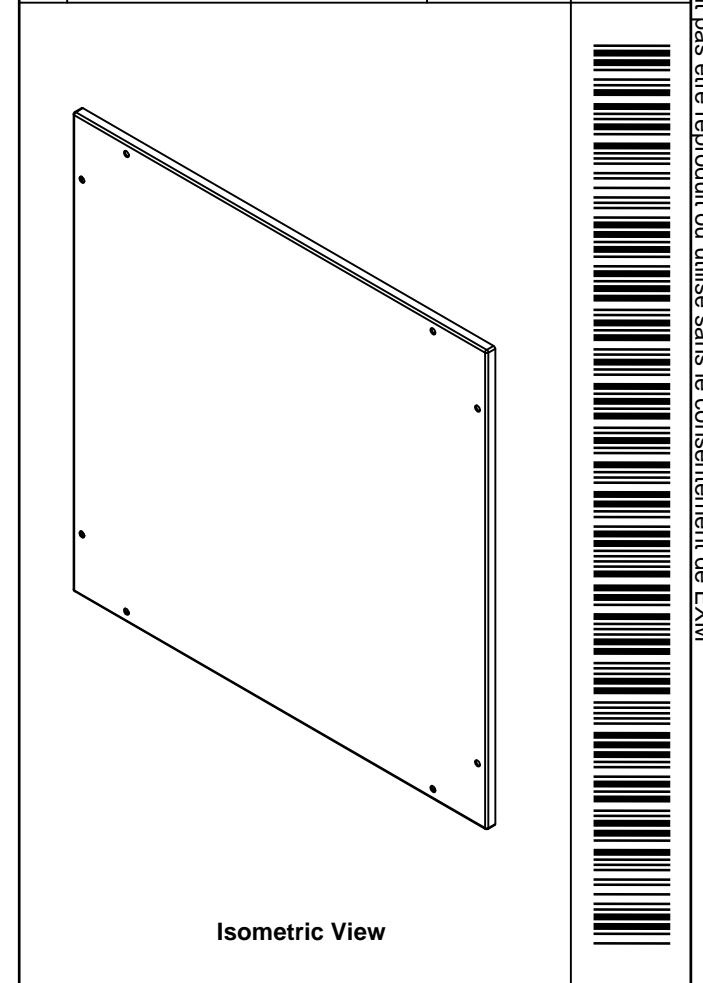

Tél: (450) 979-4373 Fax: (450) 979-4626 www.exmweb.com		Flatness Aplatissement	
		Max 3.0mm Projection	
Customer Client		Date	
Drawn By Dessiné Par		Date	
BoxCad: BoxCad		27-Jun-17	
Material Matière			
14 Ga H.R.P. & O. (1.7mm)			
Color Couleur		Finish Fini	
Asa-61 Grey		Smooth	
Description			Detail Rev.
1300DWP24" x 24" Cover			
Part Number Numéro Pièce		Rev.	3
1300DWP242408C		0	3

Qty	Part Number	Rev	Description
1	STK-Q-08350	5	Standoff M6 x 10mm
1	STK-P-02400S	0	Powder Paint (Asa-61 Grey / Smooth)
1	1300DWP242408C-P	0	1300DWP24" x 24" Cover Part
1	1300DWP242408G	0	1300DWP24" x 24" Cover Gasket
Parts List			