

This drawing is confidential and must not be reproduced or used without the consent of EXM

Ce dessin est confidentiel et ne doit pas être reproduit ou utilisé sans le consentement de EXM

APPROVED FOR PRODUCTION
APPROUVÉ POUR PRODUCTION
 SIGNATURE: _____
 NAME / NOM: _____
 DATE: _____
 Please visit: www.boxcadexm.com

No.	Revisions	Date	By/Par

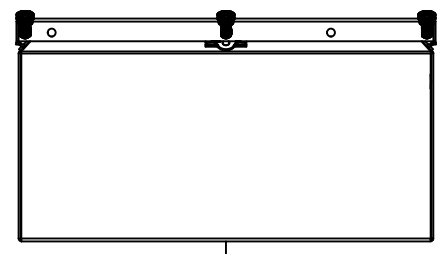

TOP

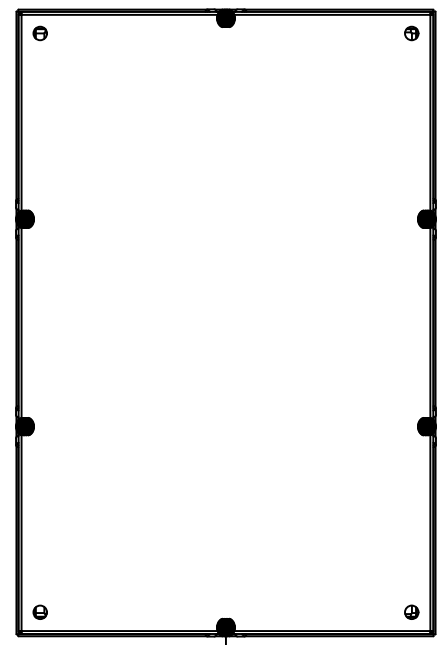

BACK

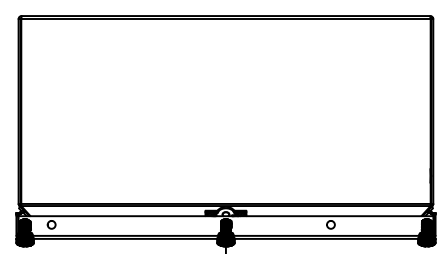

BOTTOM

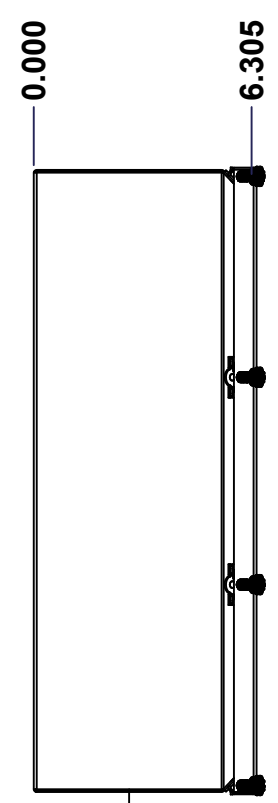

LEFT

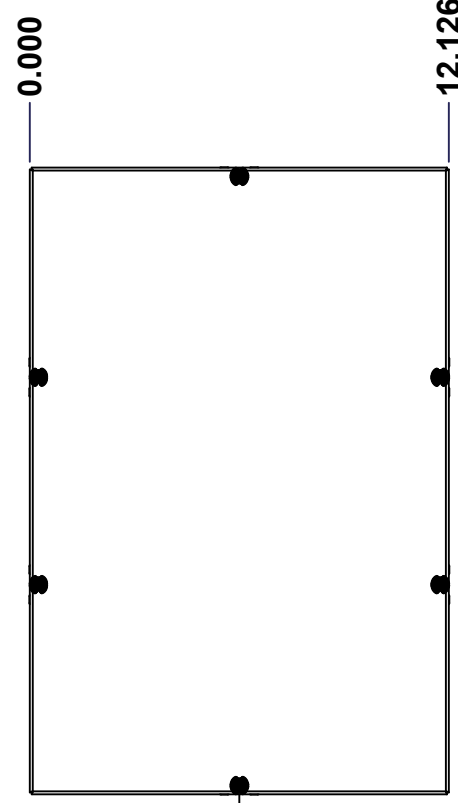

FRONT

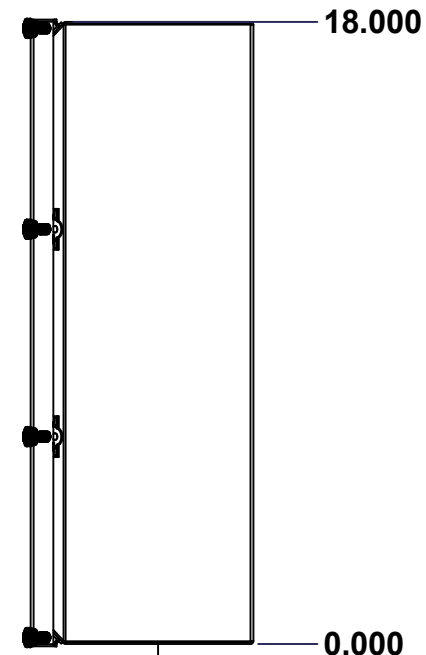

RIGHT

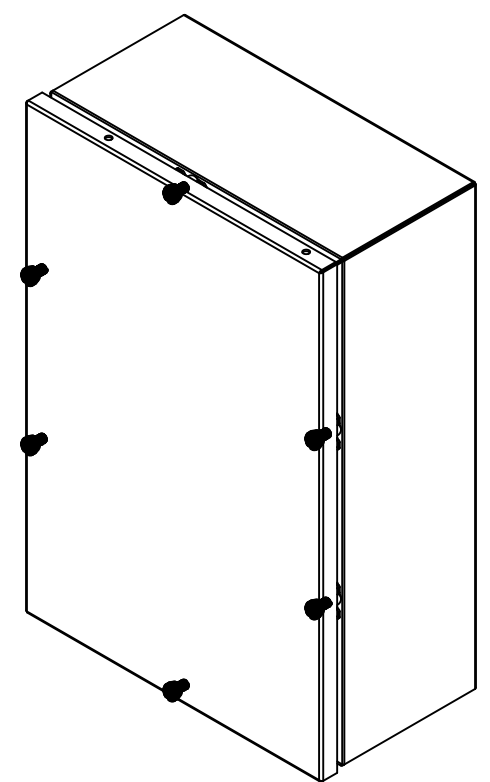

Isometric View

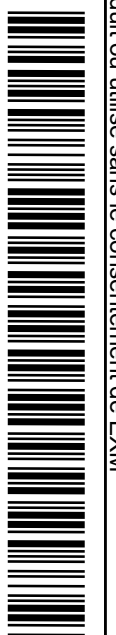

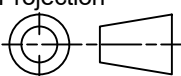
 Tél: (450) 979-4373 Fax: (450) 979-4626 www.exmweb.com		Flatness Aplatissement Max 3.0mm Projection 
Customer Client	Date	
Drawn By Dessiné Par	BoxCad: ArthurC	Date 20-Oct-20
Material Matière	16 Ga H.R.P. & O. (1.4mm)	
Color Couleur	Asa-61 Grey	Finish Fini Smooth
Description	Detail Rev.	
1412B203 Assembly		
Part Number Numéro Pièce	Rev. 0	1 / 5
1412B203		

This drawing is confidential and must not be reproduced or used without the consent of EXM

Ce dessin est confidentiel et ne doit pas être reproduit ou utilisé sans le consentement de EXM

NOTE	
ITEM	DESCRIPTION
1	NEMA 4X Enclosure
2	C/W Standard ground standoffs on box and cover
3	W/O Standard door stiffener
4	C/W Standard inner panel (Sold seperately)
5	C/W Standard inner panel mounting standoffs

APPROVED FOR PRODUCTION
APPROUVÉ POUR PRODUCTION
 SIGNATURE: _____
 NAME / NOM: _____
 DATE: _____
 Please visit: www.boxcadexm.com

No.	Revisions	Date	By/Par

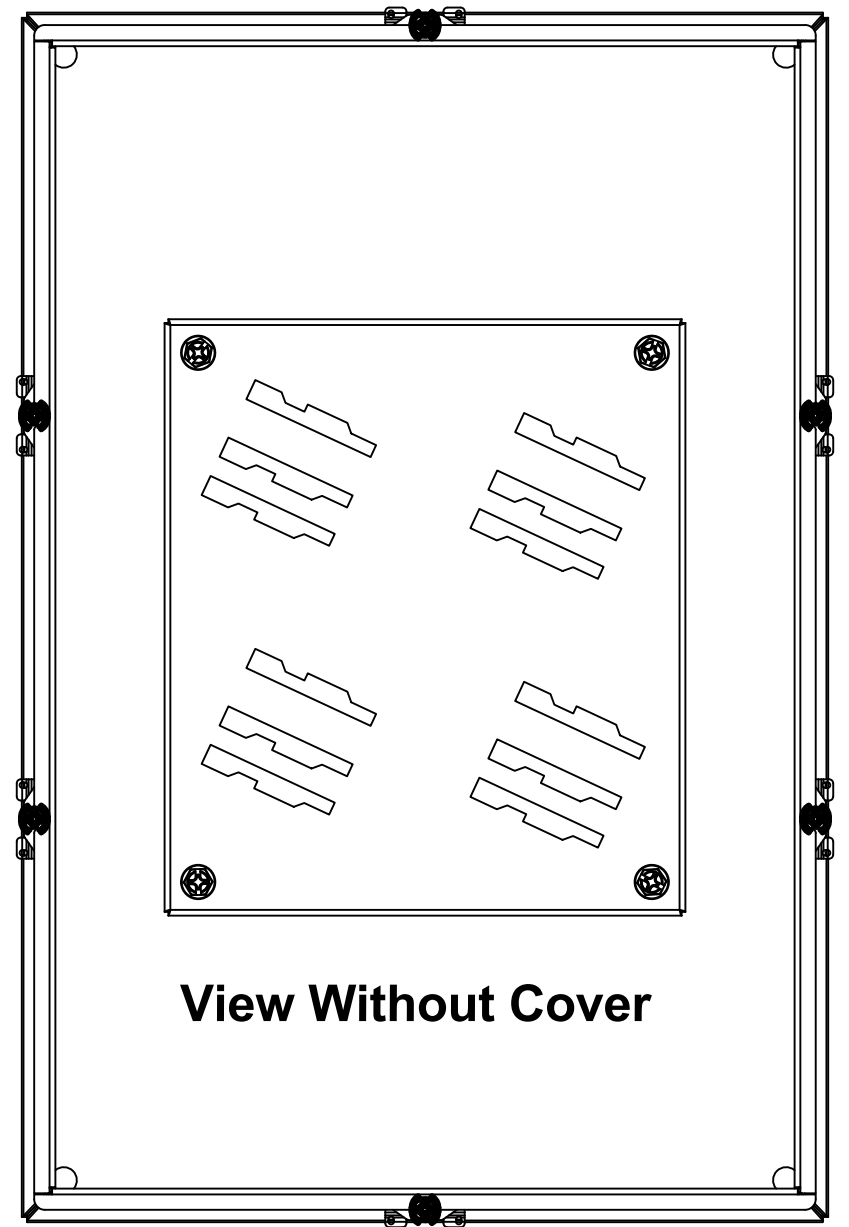

View Without Cover

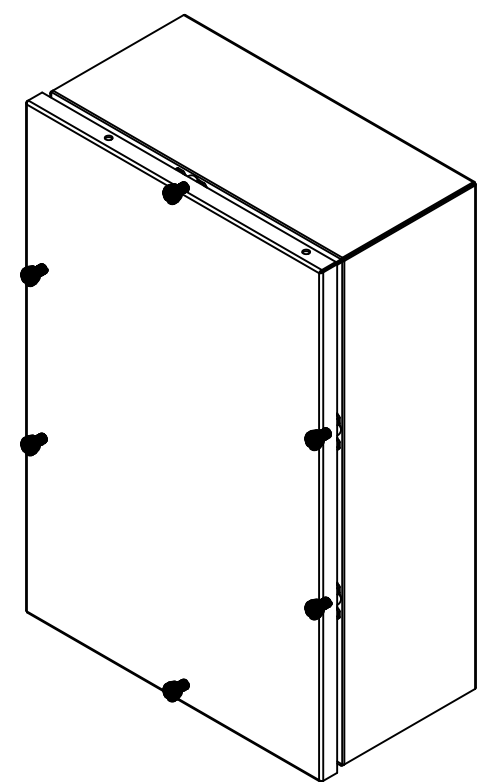

Isometric View

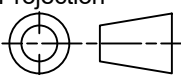

 Tél: (450) 979-4373 Fax: (450) 979-4626 www.exmweb.com	Flatness Aplatissement	Max 3.0mm
	Projection	
Customer Client	Date	
Drawn By Dessiné Par	BoxCad: ArthurC	Date 20-Oct-20
Material Matière	16 Ga H.R.P. & O. (1.4mm)	
Color Couleur	Asa-61 Grey	Finish Fini Smooth
Description	1412B203 Assembly	Detail Rev.
Part Number Numéro Pièce	1412B203	Rev. 0
Parts List		2 5

Qty	Part Number	Rev.	Description
4	STK-Q-03200	0	M6 x 8mm Hexagon/Slot Screw
1	1412B203C	0	1412B203 Cover
1	1412B203B	0	1412B203 Body

This drawing is confidential and must not be reproduced or used without the consent of EXM

Ce dessin est confidentiel et ne doit pas être reproduit ou utilisé sans le consentement de EXM

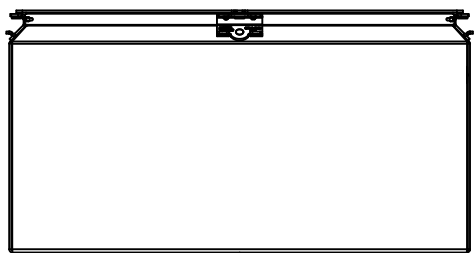

BACK

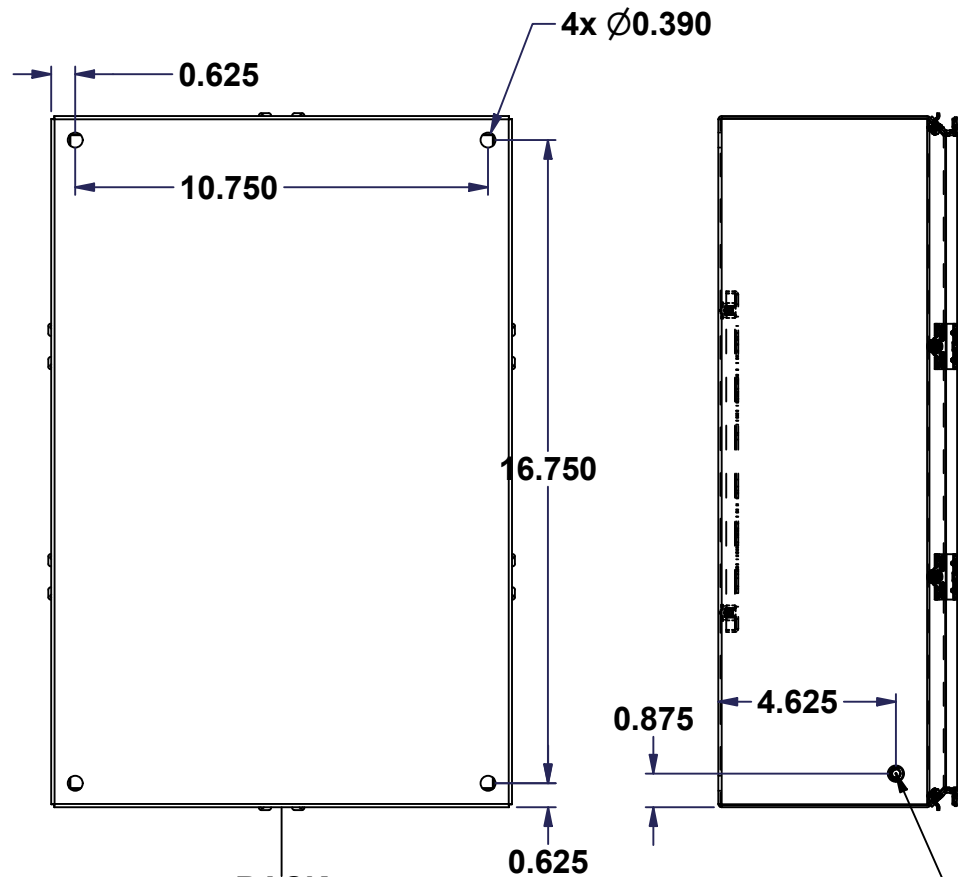

BACK

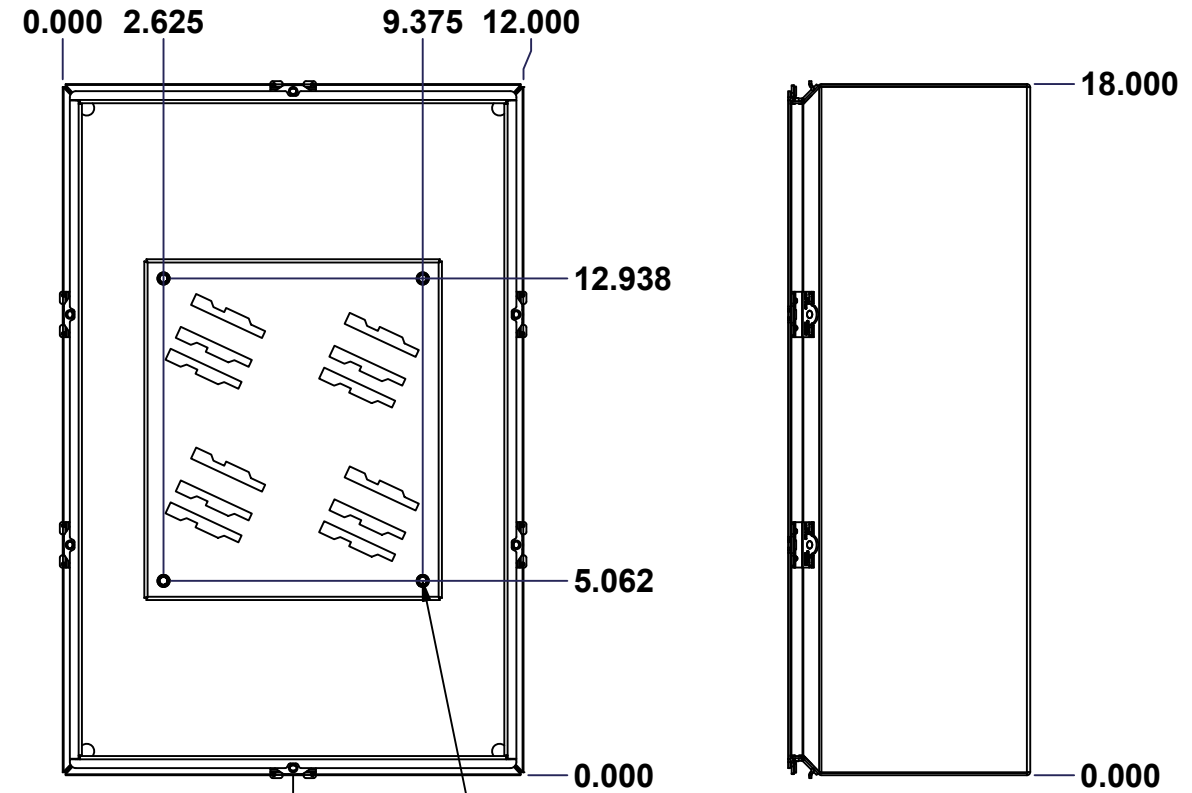

BACK

Standoff M6x10mm (Inside)

4x Standoff M6x10mm

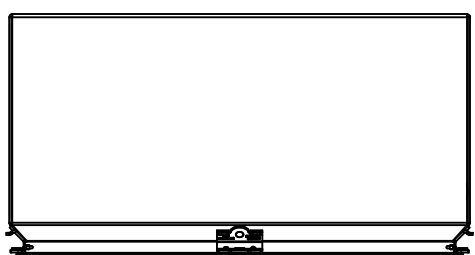

BACK

APPROVED FOR PRODUCTION
APPROUVÉ POUR PRODUCTION
 SIGNATURE: _____
 NAME / NOM: _____
 DATE: _____
 Please visit: www.boxcadexm.com

No.	Revisions	Date	By/Par

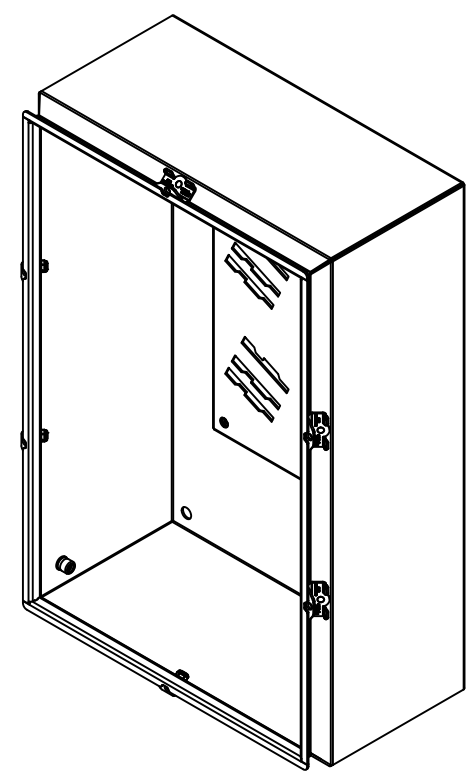

Isometric View



EXM
exm
 Tél: (450) 979-4373
 Fax: (450) 979-4626
www.exmweb.com

Flatness
 Aplatissement
 Max 3.0mm
 Projection

Customer Client
 Drawn By Dessiné Par BoxCad: ArthurC
 Material Matière 16 Ga H.R.P. & O. (1.4mm)
 Date 20-Oct-20

Color Couleur Asa-61 Grey
 Finish Fini Smooth
 Description 1412B203 Body
 Detail Rev.

Part Number Numéro Pièce **1412B203B**
 Rev. 0
 3
 5

Qty	Part Number	Rev.	Description
5	STK-Q-08350	5	Standoff M6 x 10mm
1	1412B203IP	0	1412B203 Inner Panel
1	STK-P-02400S	0	Powder Paint (Asa-61 Grey / Smooth)
5	STK-Q-08100-3	1	M5 Nylon Insert Lock Nut
1	STK-Q-08100-1	1	M5 Nylon Insert Lock Nut
1	1412B203B-P	0	1412B203 Body Part
6	DEV-STK-Q-70464	2	5412 ESSC & ESSC Stainless Steel Body Catch Assembly
Parts List			

This drawing is confidential and must not be reproduced or used without the consent of EXM

Ce dessin est confidentiel et ne doit pas être reproduit ou utilisé sans le consentement de EXM

APPROVED FOR PRODUCTION
APPROUVÉ POUR PRODUCTION
 SIGNATURE: _____
 NAME / NOM: _____
 DATE: _____
 Please visit: www.boxcadexm.com

No.	Revisions	Date	By/Par

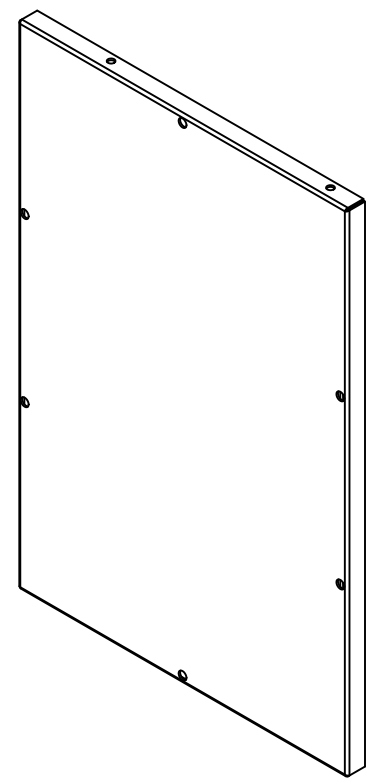
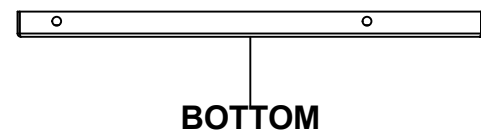
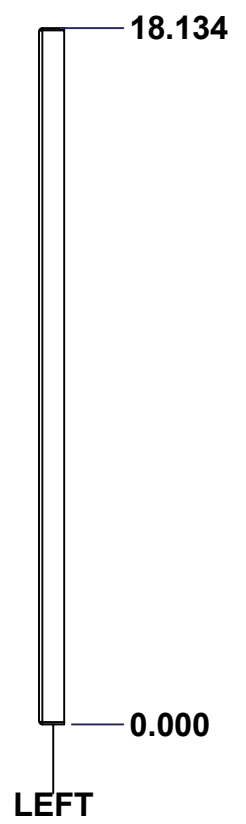
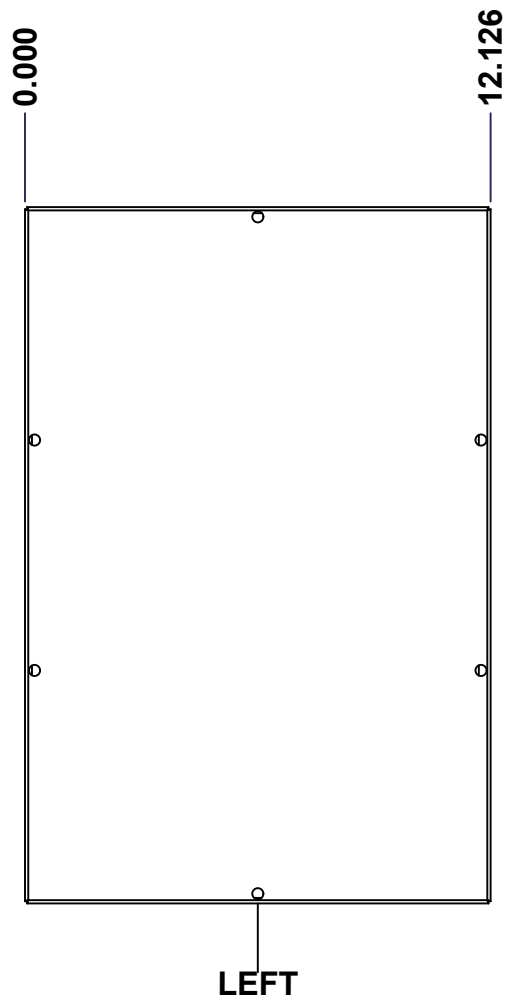
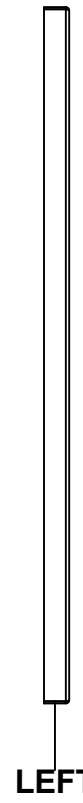
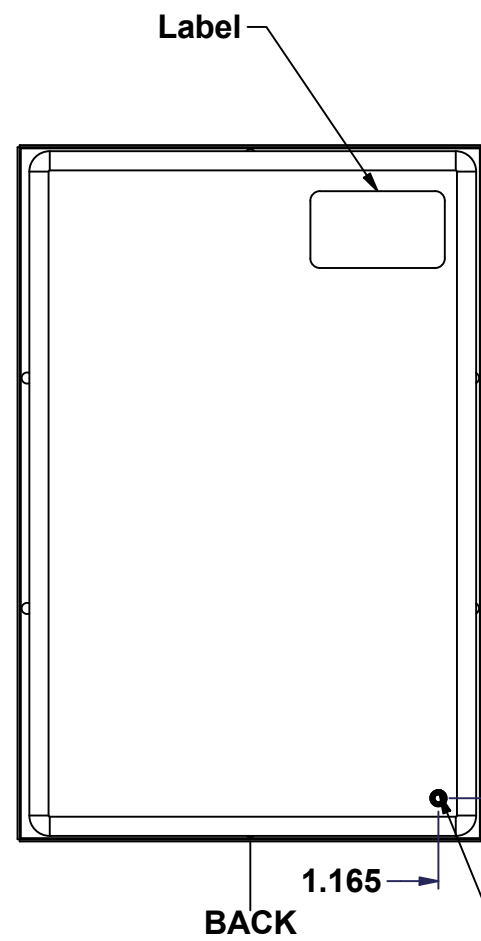
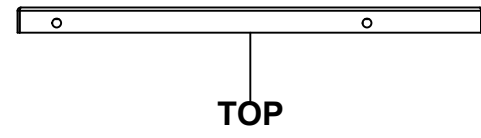

EXM
 Tél: (450) 979-4373
 Fax: (450) 979-4626
www.exmweb.com

Flatness
 Aplatissement
 Max 3.0mm
 Projection

Customer Client	Date
Drawn By Dessiné Par: BoxCad: ArthurC	Date: 20-Oct-20
Material Matière: 16 Ga H.R.P. & O. (1.4mm)	

Color Couleur: Asa-61 Grey	Finish Fini: Smooth
Description: 1412B203 Cover	Detail Rev.
Part Number Numéro Pièce: 1412B203C	Rev. 4 0

Qty	Part Number	Rev.	Description
1	STK-Q-08350	5	Standoff M6 x 10mm
1	STK-P-02400S	0	Powder Paint (Asa-61 Grey / Smooth)
1	STK-S-00100	0	3.5" x 2" Silver Milar Flexcon Sticker
1	1412B203G	0	1412B203 Gasket
1	1412B203C-P	0	1412B203 Cover Part

Parts List

This drawing is confidential and must not be reproduced or used without the consent of EXM

Ce dessin est confidentiel et ne doit pas être reproduit ou utilisé sans le consentement de EXM

APPROVED FOR PRODUCTION
APPROUVÉ POUR PRODUCTION
 SIGNATURE: _____
 NAME / NOM: _____
 DATE: _____
 Please visit: www.boxcadexm.com

No.	Revisions	Date	By/Par

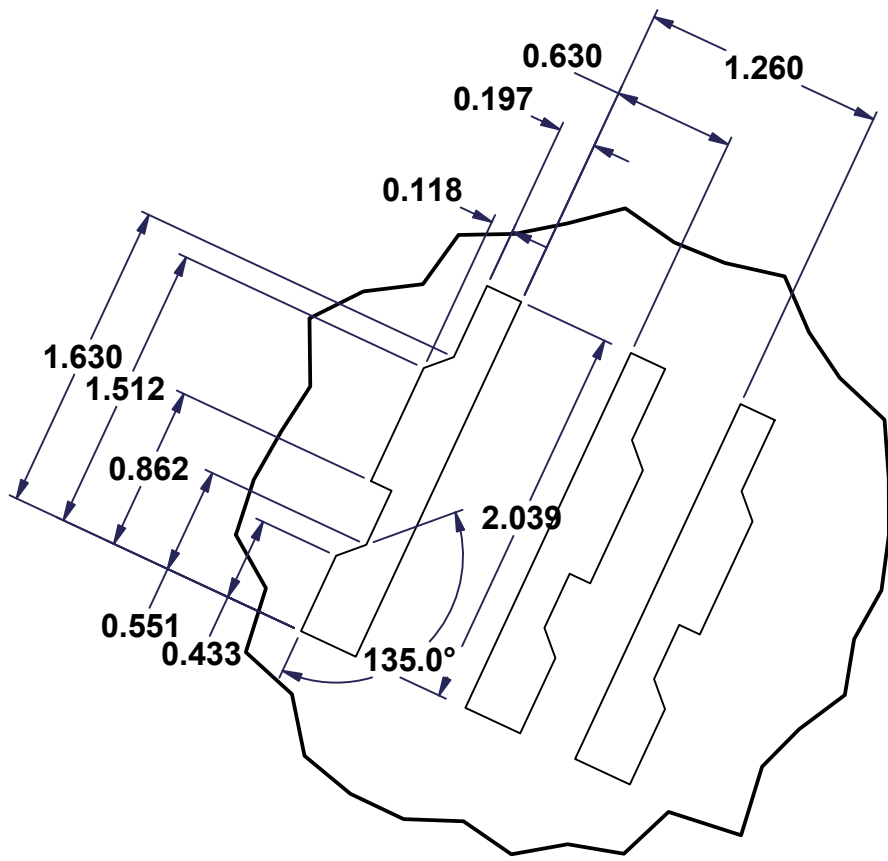

DETAIL C

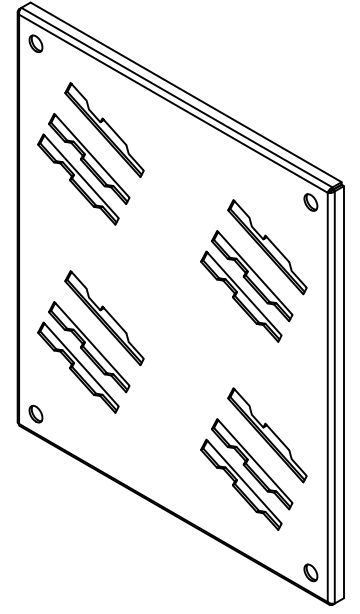
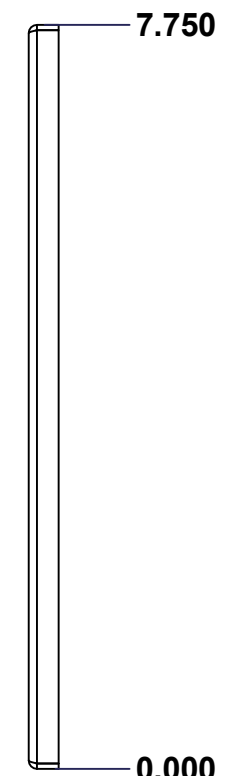
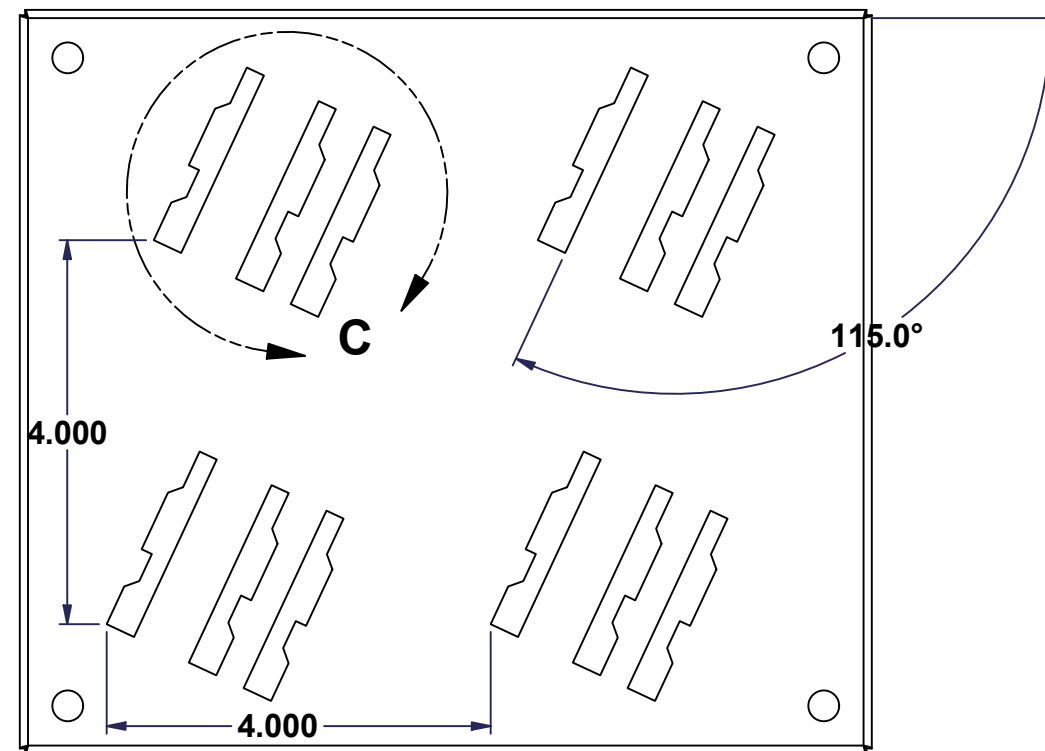
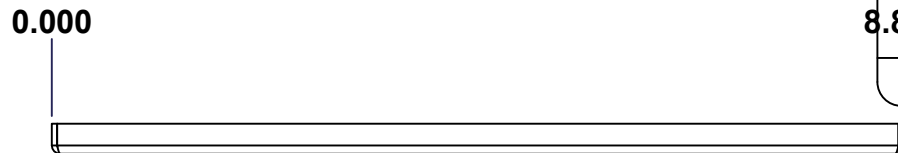

Isometric View

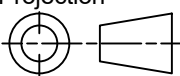

 Tél: (450) 979-4373 Fax: (450) 979-4626 www.exmweb.com		Flatness Aplatissement Max 3.0mm Projection 
Customer Client	Date	
Drawn By Dessiné Par	BoxCad: Patrick Deschênes	Date 10/21/2020
Material Matière	16 Ga Galvanized (1.4mm)	
Color Couleur	Unpainted	Finish Fini Galvanized
Description	Detail Rev.	
1412B203 Inner Panel		
Part Number Numéro Pièce	Rev. 0	5
1412B203IP		5

Qty	Part Number	Rev.	Description
1	1412BSSP74IP-P	0	1412BSSP74 Inner Panel Part

Parts List