

This drawing is confidential and must not be reproduced or used without the consent of EXM

Ce dessin est confidentiel et ne doit pas être reproduit ou utilisé sans le consentement de EXM

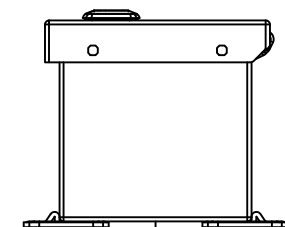

TOP

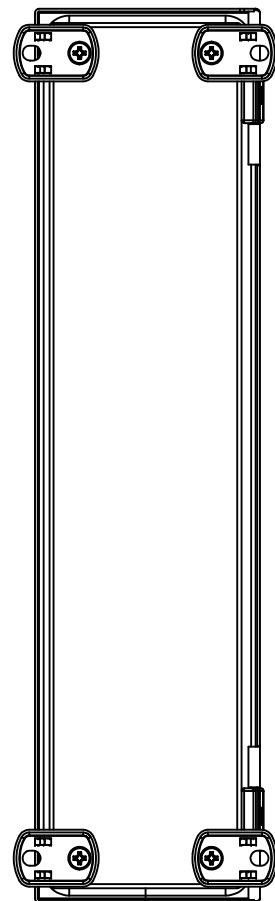

BACK

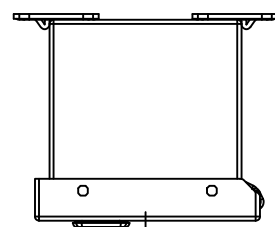

BOTTOM

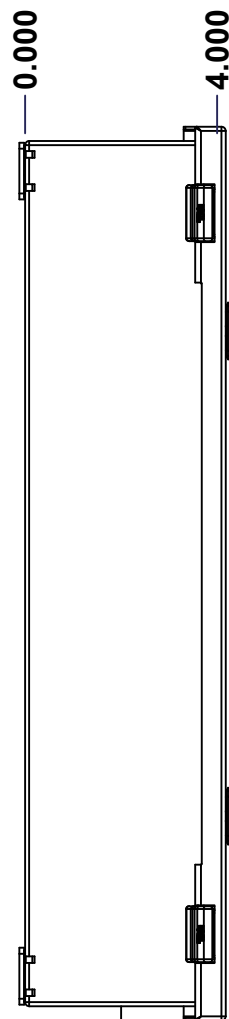

LEFT

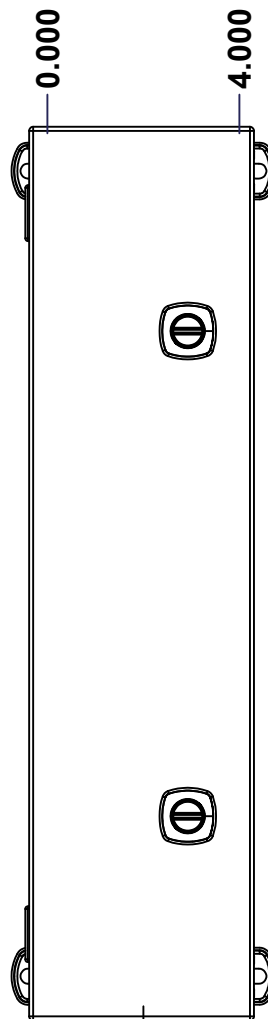

FRONT

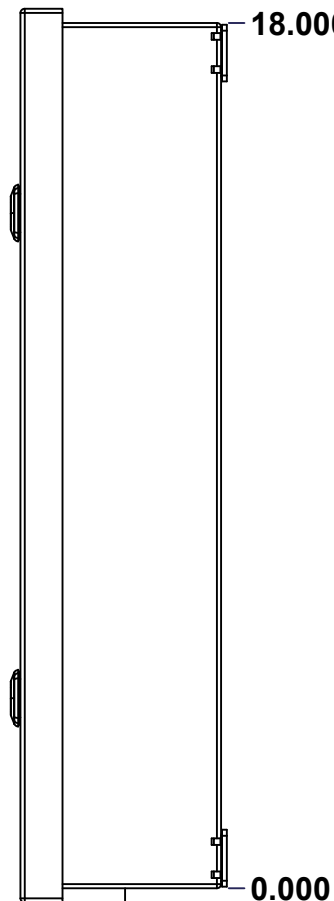

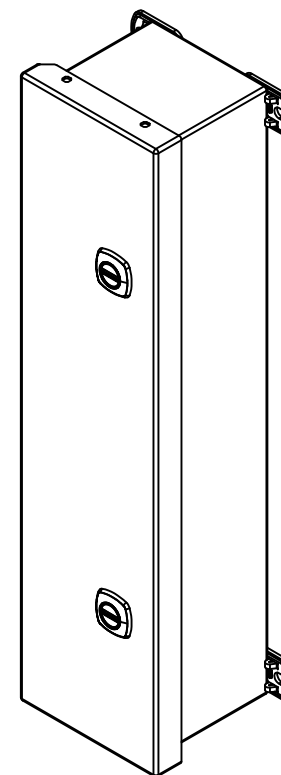

RIGHT



Isometric View



| No. | Revisions | Date | By/Par |
|-----|-----------|------|--------|
| | | | |
| | | | |
| | | | |
| | | | |

| | | |
|--|---|---|
|  Tél: (450) 979-4373 Fax: (450) 979-4626 www.exmweb.com | | Flatness Aplatissement Max 3.0mm Projection  |
| Customer Client | Date | Date |
| Drawn By Dessiné Par | BoxCad: BoxCad | Date 15-Jan-14 |
| Material Matière | 16 Ga Cold Rolled A1008 CS Type B (1.4mm) | |
| Color Couleur | Asa-61 Grey | Finish Fini Smooth |
| Description | 1412CH 18" x 4" x 4" Assembly | |
| Part Number Numéro Pièce | Rev. 0 | 1 / 2 |

SEE BILL OF MATERIAL ON LAST PAGE

1412CH040418

This drawing is confidential and must not be reproduced or used without the consent of EXM

Ce dessin est confidentiel et ne doit pas être reproduit ou utilisé sans le consentement de EXM

| NOTE | |
|------|--|
| ITEM | DESCRIPTION |
| 1 | NEMA 4/12 Enclosure |
| 2 | C/W Standard ground standoffs on box and cover |
| 3 | W/O Standard door stiffener |
| 4 | W/O Inner panel |
| 5 | W/O Inner panel mounting standoffs |

| No. | Revisions | Date | By/Par |
|-----|-----------|------|--------|
| | | | |
| | | | |
| | | | |
| | | | |
| | | | |
| | | | |

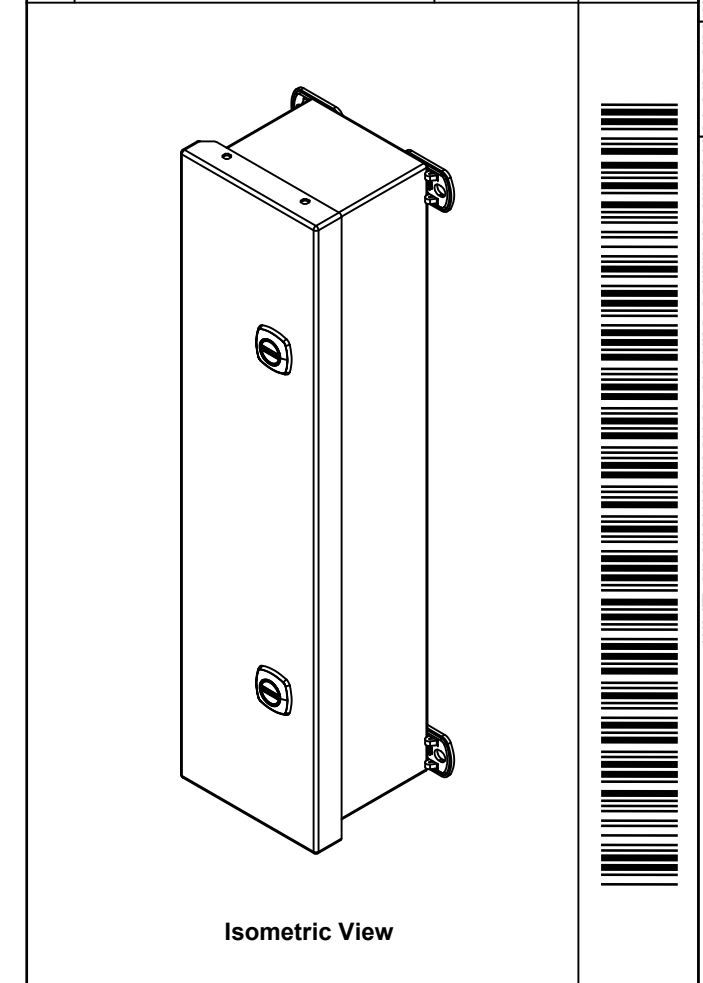

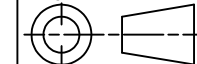
| | |
|--|---|
|  Tél: (450) 979-4373 Fax: (450) 979-4626 www.exmweb.com | Flatness Aplatissement |
| | Max 3.0mm |
| Projection |  |
| Customer Client | Date |
| Drawn By Dessiné Par | Date 15-Jan-14 |
| Material Matière | 16 Ga Cold Rolled A1008 CS Type B (1.4mm) |
| Color Couleur | Asa-61 Grey |
| Finish Fini | Smooth |

| PACKING | | |
|----------------------|-----|---|
| ITEM | QTY | DESCRIPTION |
| Cardboard sleeve | 1 | Top |
| Thermal plastic film | 1 | Use with Packing Tunnel Wrapper Machine |
| Packaging label | 1 | White label with product number |

| Qty | Part Number | Rev | Description |
|------------|---------------|-----|---------------------------|
| 1 | 1412CH040418C | 0 | 1412CH 18" x 4" Cover |
| 1 | 1412CH040418B | 0 | 1412CH 18" x 4" x 4" Body |
| 2 | STK-K-02570 | 0 | 1412 CH Accessory Kit |
| 2 | STK-Q-08100 | 1 | M5 Nylon Insert Lock Nut |
| Parts List | | | |

| | |
|-------------------------------|-------------|
| Description | Detail Rev. |
| 1412CH 18" x 4" x 4" Assembly | |
| Part Number Numéro Pièce | Rev. |
| 1412CH040418 | 0 |
| | 2 |
| | 2 |

This drawing is confidential and must not be reproduced or used without the consent of EXM

Ce dessin est confidentiel et ne doit pas être reproduit ou utilisé sans le consentement de EXM

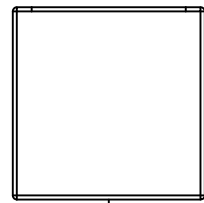

TOP

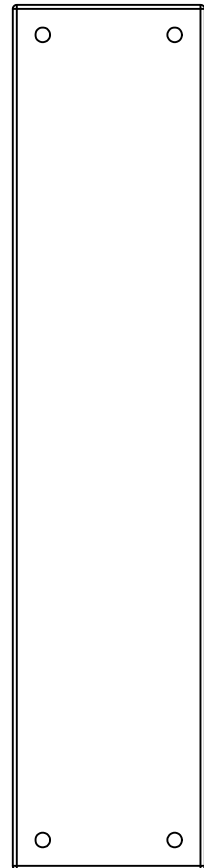

BACK

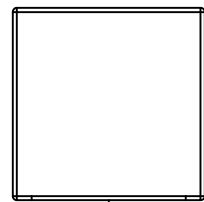

BOTTOM

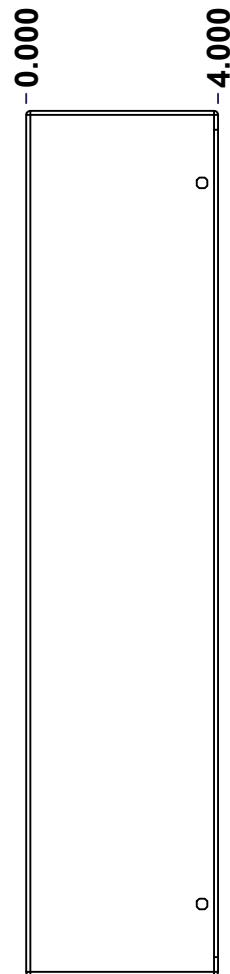

LEFT

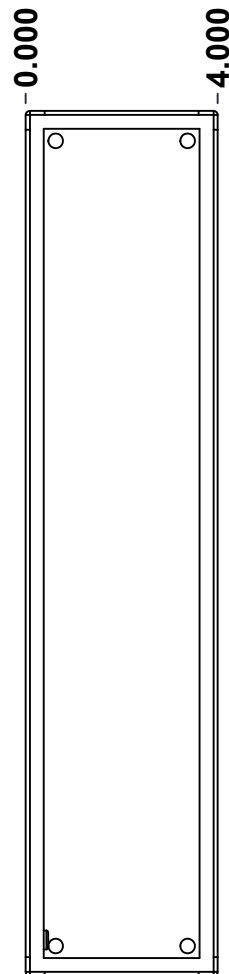

FRONT

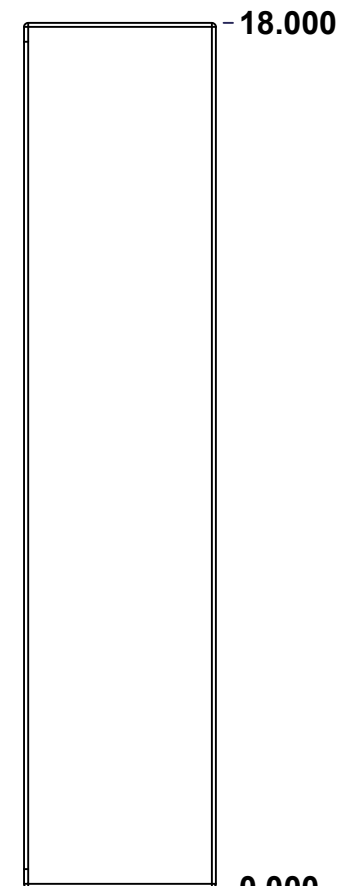

RIGHT

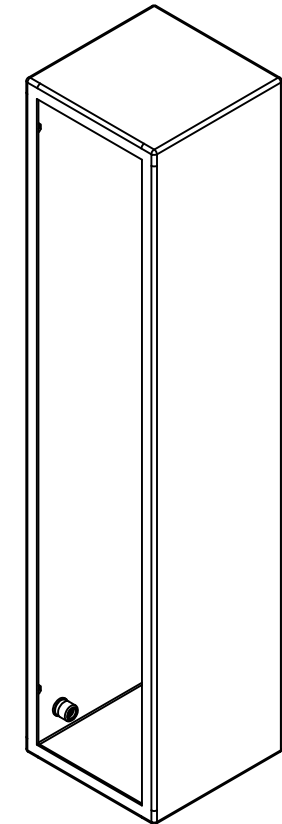

Isometric View

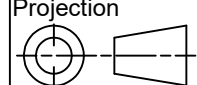

| No. | Revisions | Date | By/Par |
|-----|-----------|------|--------|
| | | | |
| | | | |
| | | | |
| | | | |
| | | | |

| | | |
|--|---|---|
|  Tél: (450) 979-4373 Fax: (450) 979-4626 www.exmweb.com | | Flatness Aplatissement Max 3.0mm Projection  |
| Customer Client | Date | |
| Drawn By Dessiné Par | BoxCad: BoxCad | Date 15-Jan-14 |
| Material Matière | 16 Ga Cold Rolled A1008 CS Type B (1.4mm) | |
| Color Couleur | Asa-61 Grey | Finish Finis Smooth |
| Description | 1412CH 18" x 4" x 4" Body | |
| Part Number Numéro Pièce | Rev. 0 | 1/7 |

SEE BILL OF MATERIAL ON LAST PAGE

1412CH040418B

This drawing is confidential and must not be reproduced or used without the consent of EXM

Ce dessin est confidentiel et ne doit pas être reproduit ou utilisé sans le consentement de EXM

| No. | Revisions | Date | By/Par |
|-----|-----------|------|--------|
| | | | |
| | | | |
| | | | |
| | | | |
| | | | |

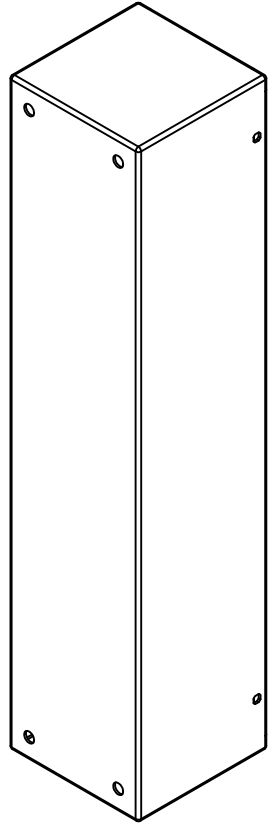

Isometric View

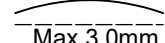
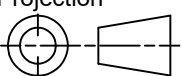

| | | |
|--|---|---|
|  Tél: (450) 979-4373 Fax: (450) 979-4626 www.exmweb.com | | Flatness Aplatissement  Max 3.0mm Projection  |
| Customer Client | Date | |
| Drawn By Dessiné Par | BoxCad: BoxCad | Date 15-Jan-14 |
| Material Matière | 16 Ga Cold Rolled A1008 CS Type B (1.4mm) | |
| Color Couleur | Asa-61 Grey | Finish Fini Smooth |
| Description | 1412CH 18" x 4" x 4" Body | Detail Rev. |
| Part Number Numéro Pièce | 1412CH040418B | Rev. 7 |
| Qty Part_Number Rev Description Parts List | | 7 |

| | | | |
|------------|-----------------|-----|-------------------------------------|
| 1 | 1412CH040418B-P | 0 | 1412CH 18" x 4" x 4" Body Part |
| 1 | STK-P-02400S | 0 | Powder Paint (Asa-61 Grey / Smooth) |
| 1 | STK-Q-08350 | 5 | Standoff M6 x 10mm |
| Qty | Part_Number | Rev | Description |
| Parts List | | | |

This drawing is confidential and must not be reproduced or used without the consent of EXM

Ce dessin est confidentiel et ne doit pas être reproduit ou utilisé sans le consentement de EXM

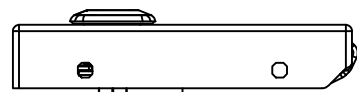

TOP

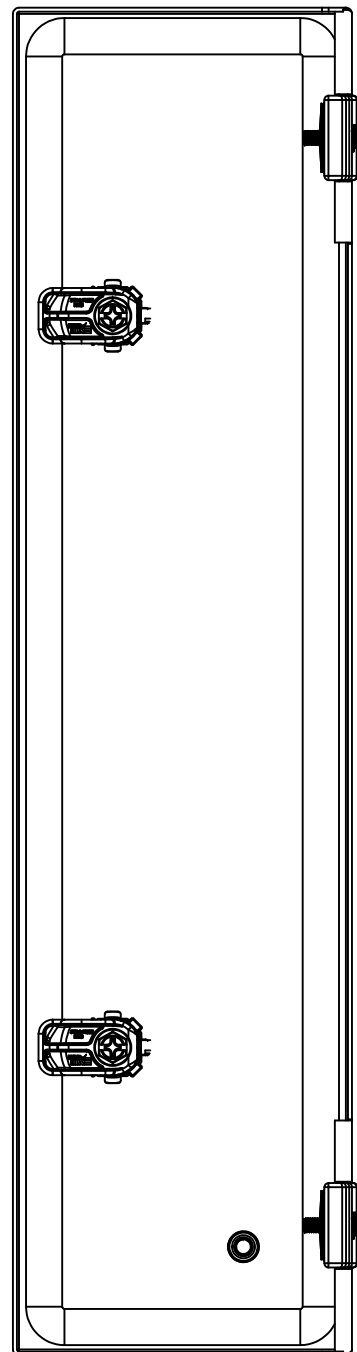

BACK



BOTTOM

0.000
0.875

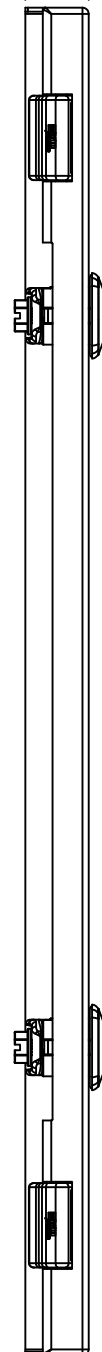

LEFT

0.000
4.687

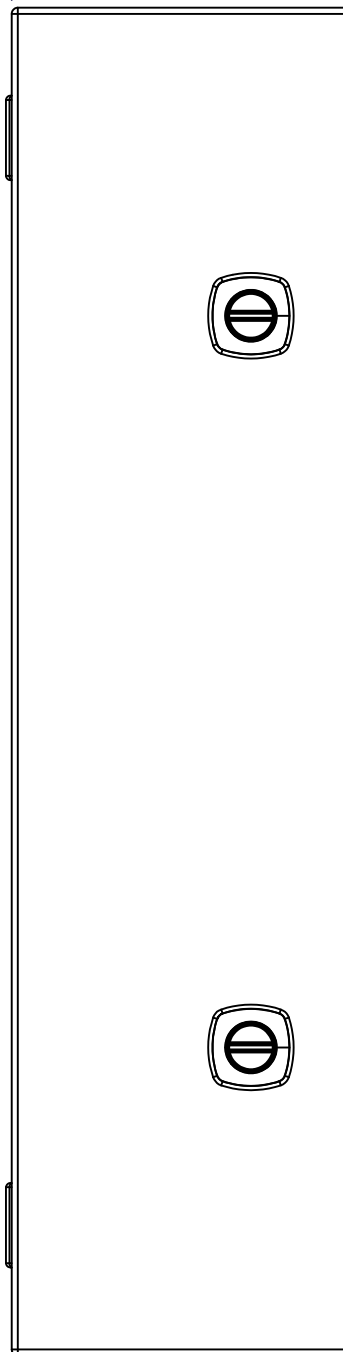

FRONT

18.592



RIGHT

0.000

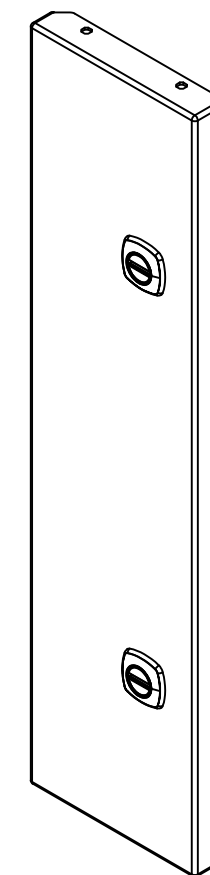

Isometric View

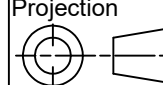

| No. | Revisions | Date | By/Par |
|-----|-----------|------|--------|
| | | | |
| | | | |
| | | | |
| | | | |
| | | | |

| | | |
|--|---|---|
|  Tél: (450) 979-4373 Fax: (450) 979-4626 www.exmweb.com | | Flatness Aplatissement Max 3.0mm Projection  |
| Customer Client | Date | Date |
| Drawn By Dessiné Par | BoxCad: BoxCad | 15-Jan-14 |
| Material Matière | 16 Ga Cold Rolled A1008 CS Type B (1.4mm) | |
| Color Couleur | Asa-61 Grey | Finish Fini: Smooth |
| Description | 1412CH 18" x 4" Cover | |
| Part Number Numéro Pièce | Rev. 0 | 1/3 |
| 1412CH040418C | | |

SEE BILL OF MATERIAL ON LAST PAGE

This drawing is confidential and must not be reproduced or used without the consent of EXM

Ce dessin est confidentiel et ne doit pas être reproduit ou utilisé sans le consentement de EXM

| STANDARD FEATURES ARE NOT LISTED IN THIS HOLE TABLE | | | |
|---|-------|--------|-----------------------------|
| HOLE TABLE - FRONT VIEW (CUSTOM FEATURE ONLY) | | | |
| CUT-OUT | XDIM | YDIM | DESCRIPTION |
| 1 | 3.307 | 14.342 | LOCK 880 SCQ4CH-SL @ 180.0° |
| 2 | 3.307 | 4.250 | LOCK 880 SCQ4CH-SL @ 180.0° |

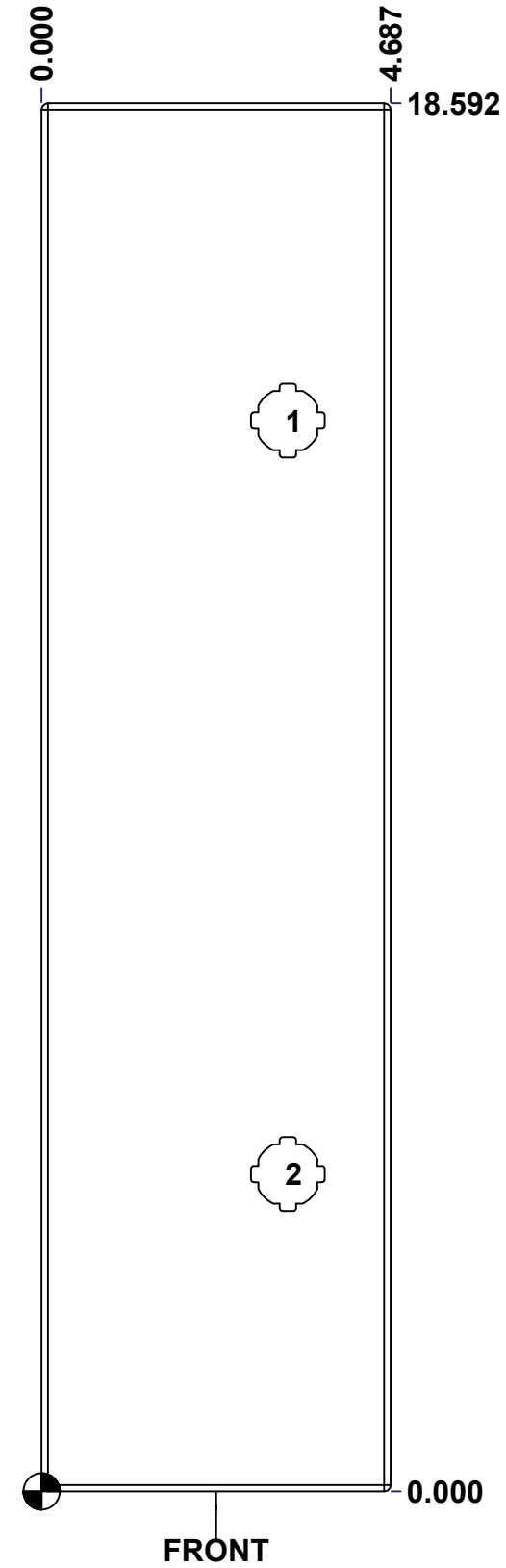



| | | | |
|--|-----------------------------|----------|--------|
| | Description | Status | |
| | 1412CH 18" x 4" Cover | (NULL) | |
| | Part Number Numéro Pièce | Rev. | |
| | 1412CH040418C | 0 | 2 3 |

This drawing is confidential and must not be reproduced or used without the consent of EXM

Ce dessin est confidentiel et ne doit pas être reproduit ou utilisé sans le consentement de EXM

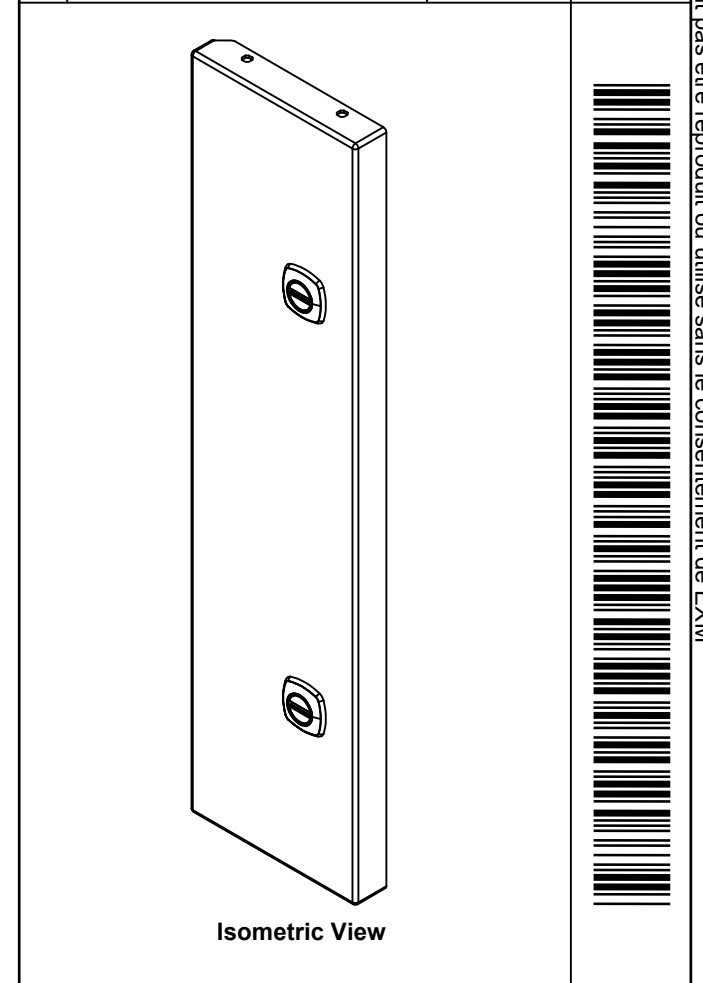
| No. | Revisions | Date | By/Par |
|-----|-----------|------|--------|
| | | | |
| | | | |
| | | | |
| | | | |
| | | | |

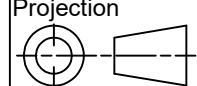

| | | | |
|--|--|---|-------------|
|  Tél: (450) 979-4373 Fax: (450) 979-4626 www.exmweb.com | | Flatness Aplatissement Max 3.0mm Projection  | |
| Customer Client | | Date | |
| Drawn By / Dessiné Par: BoxCad: BoxCad | | Date: 15-Jan-14 | |
| Material / Matière: 16 Ga Cold Rolled A1008 CS Type B (1.4mm) | | | |
| Color / Couleur: Asa-61 Grey | | Finish / Fini: Smooth | |
| Description: 1412CH 18" x 4" Cover | | | Detail Rev. |
| Part Number / Numéro Pièce: 1412CH040418C | | | Rev. 3 |

| 1 | 1412CH040418G | 0 | 1412CH 18" x 4" Gasket |
|------------|-----------------|-----|-------------------------------------|
| 1 | STK-P-02400S | 0 | Powder Paint (Asa-61 Grey / Smooth) |
| 1 | STK-Q-08350 | 5 | Standoff M6 x 10mm |
| 1 | 1412CH040418C-P | 0 | 1412CH 18" x 4" Cover Part |
| 2 | STK-A-33033 | 4 | 5412 ESMCH Hinge |
| 2 | 880 SCQ4CH-SL | 0 | 5412 CH 1/4 Turn Lock |
| Qty | Part Number | Rev | Description |
| Parts List | | | |