

All knockouts are actual size / Les disques défonçables sont grandeur réel
 All dimensions are before paint / Toutes les dimensions sont avant peinture

This drawing is confidential and must not be reproduced or used without the consent of EXM

Ce dessin est confidentiel et ne doit pas être reproduit ou utilisé sans le consentement de EXM

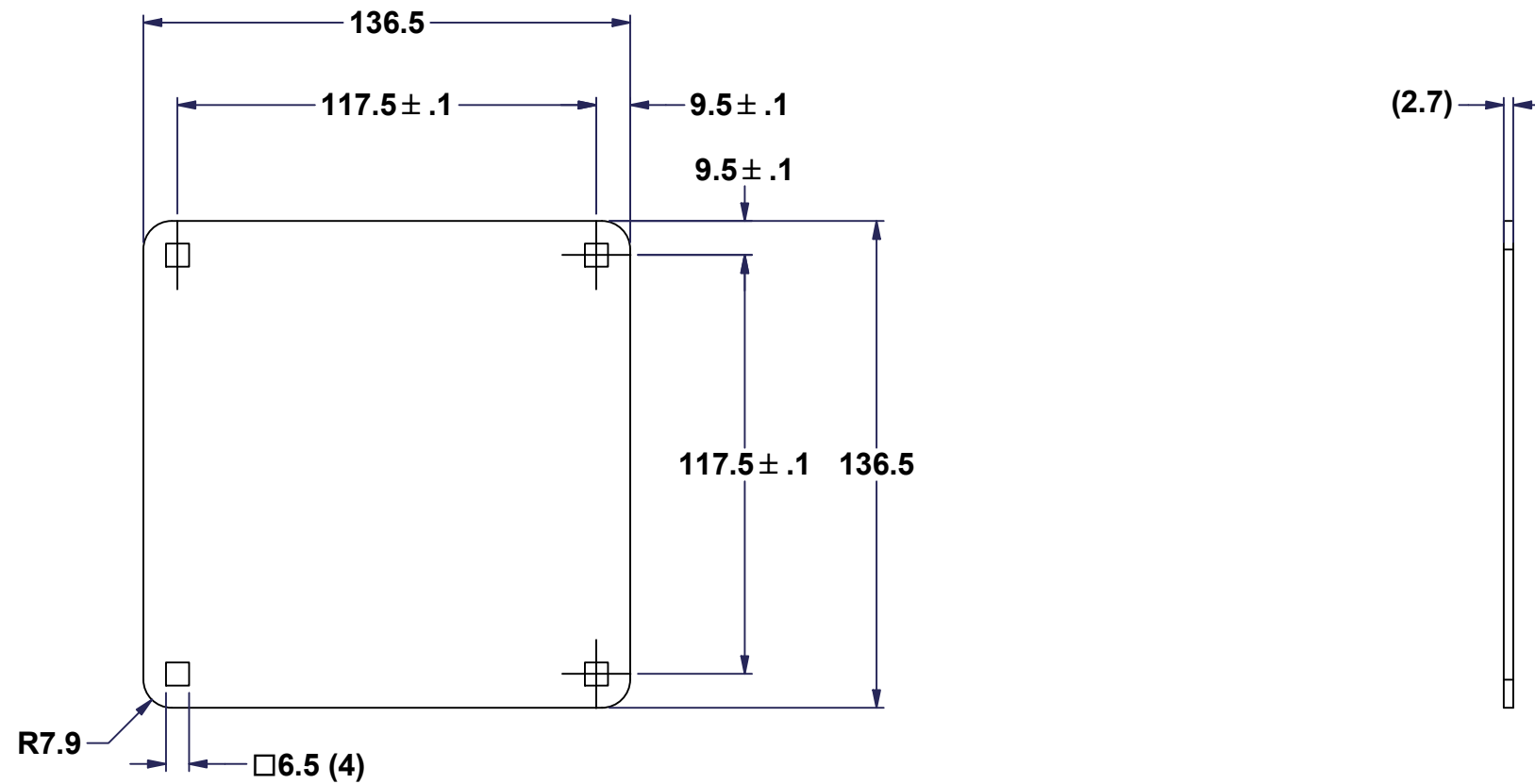

No.	Revisions	Date	By/Par

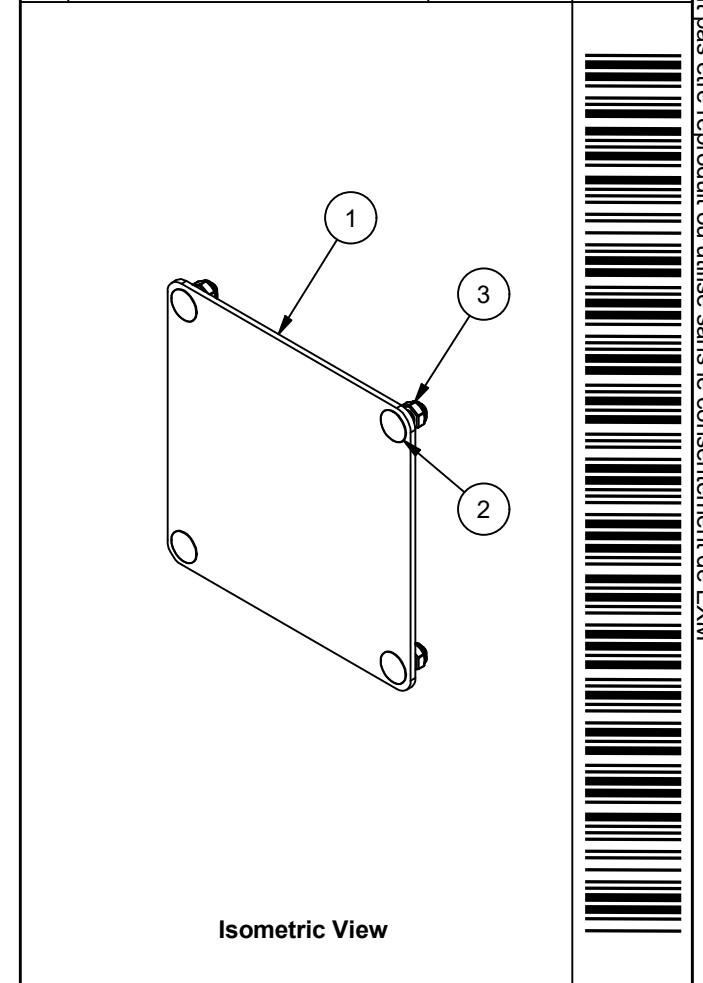

Isometric View

Note:
 - Remove all sharp corners and deburr edges

Parts List							
Item	Qty	Part Number	Rev	Description	Material	Color	Finish
1	1	1412CP4070-P	0	1412 CP - Pull Through Wireway - Closing Plate Part	12 Ga H.R.P. & O.	Asa-61 Grey	Smooth
2	4	STK-Q-00266	0	M6 x 16mm Stainless Steel 316 Carriage Bolt	Stainless Steel 316	Bright	Reverse Chrome Plated
3	4	STK-Q-07225	0	M6 Stainless Steel Nylon Insert Lock Nut	See Part List	See Part List	See Part List
4	1	STK-P-02400S	0	Powder Paint (Asa-61 Grey / Smooth)	Polyester-Epoxy Hybrid	Asa-61 Grey	Smooth

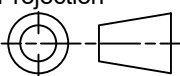
 Tél: (450) 979-4373 Fax: (450) 979-4626 www.exmweb.com	Flatness Aplatissement Max 3.0mm
	Projection 
Customer Client	Date
Drawn By Dessiné Par julienp	Date 26-May-17
Material Matière	See Part List
Color Couleur	See Part List
Finish Fini	See Part List
Description 1412 CP - Pull Through Wireway - Closing Plate Assembly	Detail Rev.
Part Number Numéro Pièce 1412CP4070	Rev. 0

1/1