

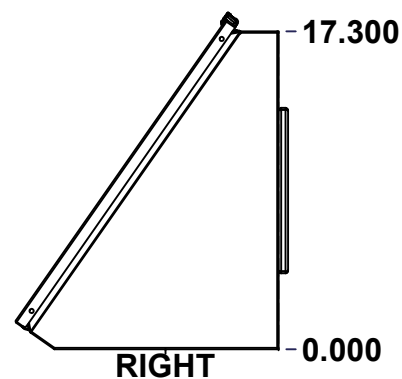

This drawing is confidential and must not be reproduced or used without the consent of EXM

Ce dessin est confidentiel et ne doit pas être reproduit ou utilisé sans le consentement de EXM

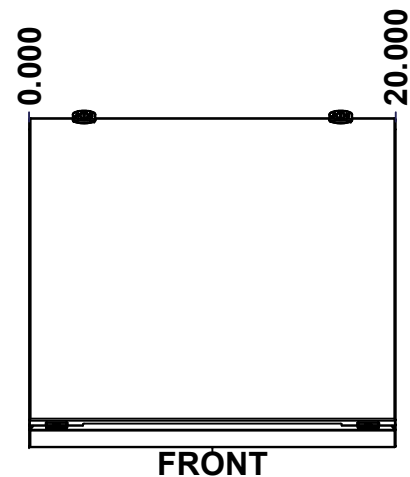
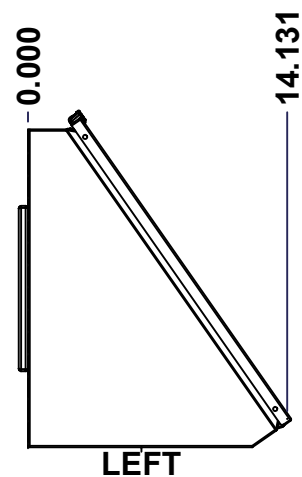
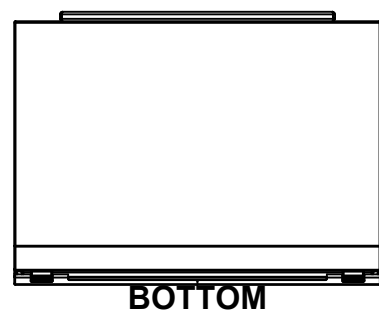
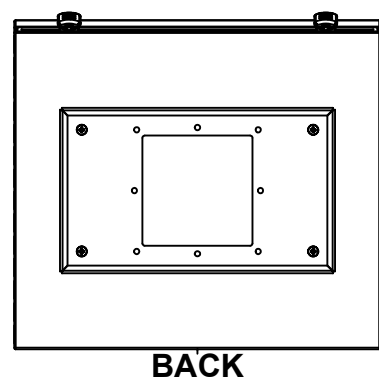
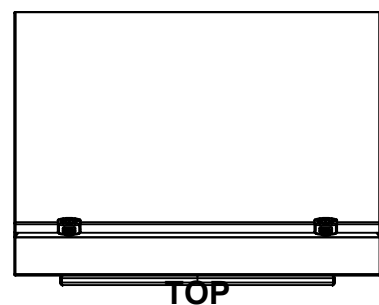
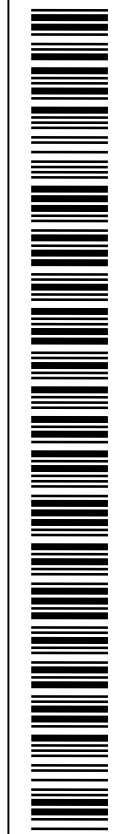
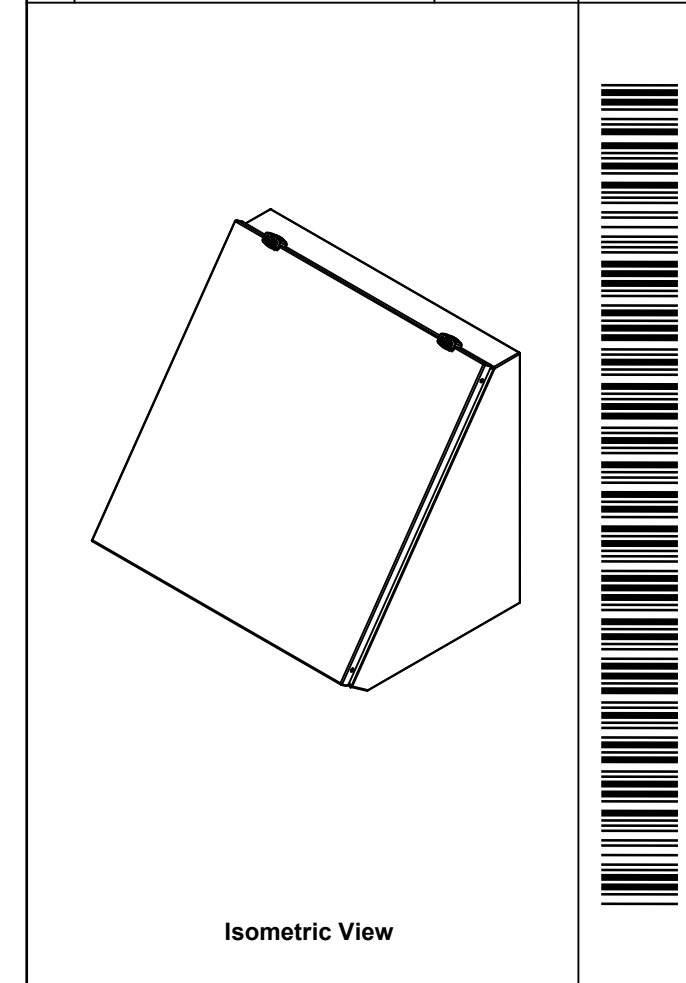

No.	Revisions	Date	By/Par



 Tél: (450) 979-4373 Fax: (450) 979-4626 www.exmweb.com		Flatness Aplatissement	
		Max 3.0mm	
Customer Client		Date	
Drawn By Dessiné Par BoxCad: BoxCad		Date 12/5/2013	
Material Matière 16 Ga Cold Rolled A1008 CS Type B (1.4mm)			
Color Couleur Asa-61 Grey		Finish Fini Smooth	
Description 1412CSE 20" x 20" x 14.019" Assembly			Detail Rev.
Part Number Numéro Pièce 1412CSE202013		Rev. 0	1 2

SEE BILL OF MATERIAL ON LAST PAGE

This drawing is confidential and must not be reproduced or used without the consent of EXM

Ce dessin est confidentiel et ne doit pas être reproduit ou utilisé sans le consentement de EXM

NOTE	
ITEM	DESCRIPTION
1	NEMA 4/12 Enclosure
2	C/W Standard ground standoffs on box and cover
3	W/O Standard door stiffener
4	W/O Inner panel
5	W/O Inner panel mounting standoffs

No.	Revisions	Date	By/Par

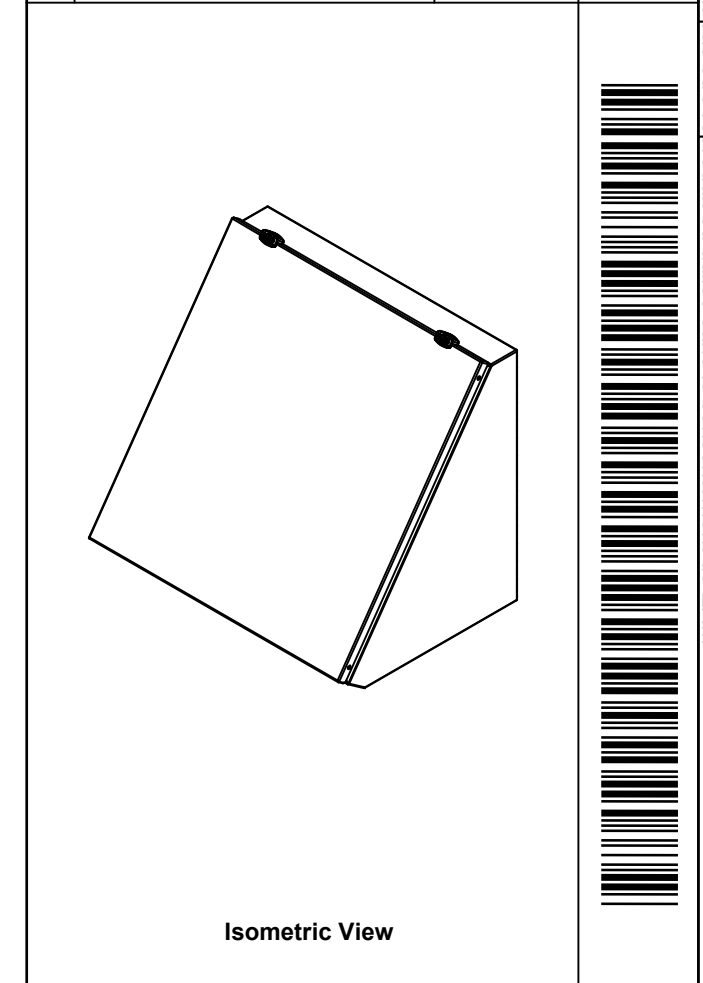

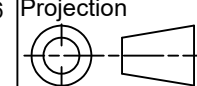
 Tél: (450) 979-4373 Fax: (450) 979-4626 www.exmweb.com		Flatness Aplatissement Max 3.0mm Projection 
Customer Client	Date	
Drawn By Dessiné Par	BoxCad: BoxCad	Date 12/5/2013
Material Matière	16 Ga Cold Rolled A1008 CS Type B (1.4mm)	
Color Couleur	Asa-61 Grey	Finish Fini Smooth
Description	Detail Rev.	
1412CSE 20" x 20" x 14.019" Assembly		
Part Number Numéro Pièce	1412CSE202013	Rev. 2
		0

PACKING		
ITEM	QTY	DESCRIPTION
Cardboard sleeve	2	Top and Bottom
Cardboard strip	2	Between back of enclosure and inner panel
Plastic bag	1	To protect cover surface and inside gasket
Plastic strap - Black	2	To Squeeze the 2 cardboard sleeve together
Packaging label	1	White label with product number

Qty	Part Number	Rev	Description
1	1412CSE202013C	0	1412CSE 20" x 20" Cover
1	1412CSE202013B	0	1412CSE 20" x 20" x 14.019" Body
2	880 GS115	0	Gas Spring 115N/12Kg/26Lbs
2	STK-Q-08100	1	M5 Nylon Insert Lock Nut
Parts List			

This drawing is confidential and must not be reproduced or used without the consent of EXM

Ce dessin est confidentiel et ne doit pas être reproduit ou utilisé sans le consentement de EXM

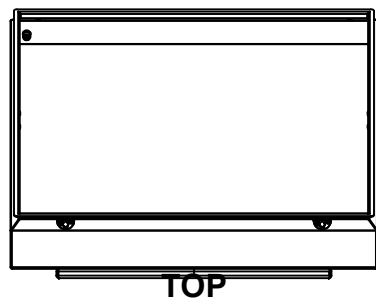

TOP

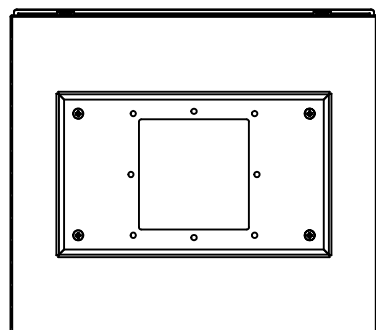

BACK

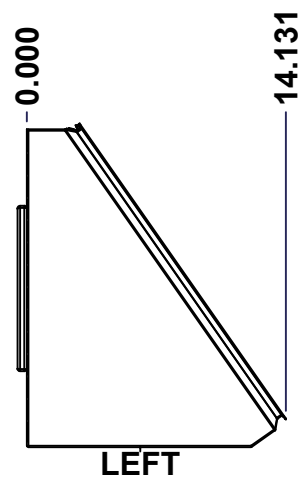

LEFT

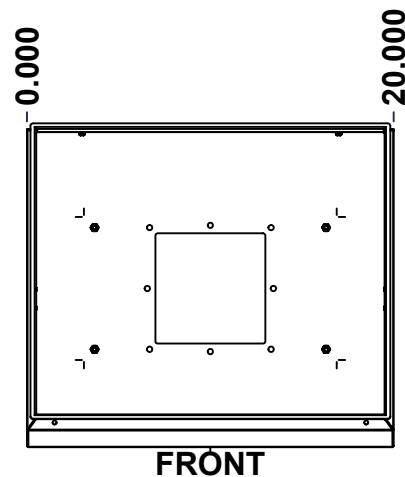

FRONT

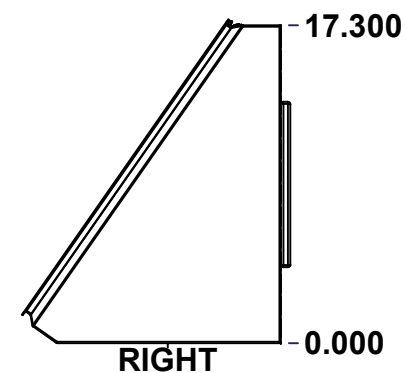

RIGHT

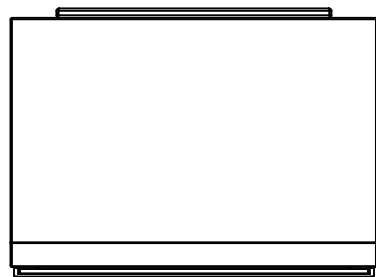

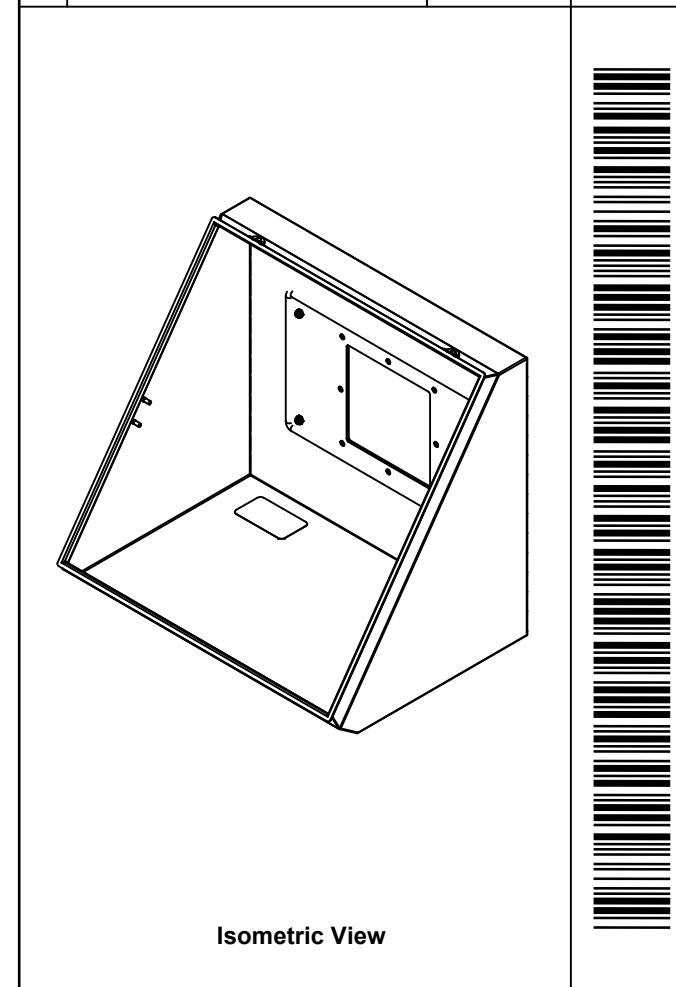

BOTTOM

No.	Revisions	Date	By/Par



Isometric View

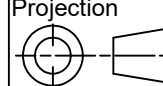

 Tél: (450) 979-4373 Fax: (450) 979-4626 www.exmweb.com		Flatness Aplatissement  Max 3.0mm Projection 
Customer Client	Date	
Drawn By Dessiné Par	BoxCad: BoxCad	Date 12/5/2013
Material Matière	16 Ga Cold Rolled A1008 CS Type B (1.4mm)	
Color Couleur	Asa-61 Grey	Finish Finis Smooth
Description	Detail Rev.	
1412CSE 20" x 20" x 14.019" Body		
Part Number Numéro Pièce	Rev.	1 7
1412CSE202013B	0	

SEE BILL OF MATERIAL ON LAST PAGE

This drawing is confidential and must not be reproduced or used without the consent of EXM

Ce dessin est confidentiel et ne doit pas être reproduit ou utilisé sans le consentement de EXM

STANDARD FEATURES ARE NOT LISTED IN THIS HOLE TABLE			
HOLE TABLE - RIGHT VIEW (CUSTOM FEATURE ONLY)			
CUT-OUT	XDIM	YDIM	DESCRIPTION
1	8.457	7.560	STUDSM5 x 12mm (Inside)
2	7.734	8.592	STUDSM5 x 12mm (Inside)

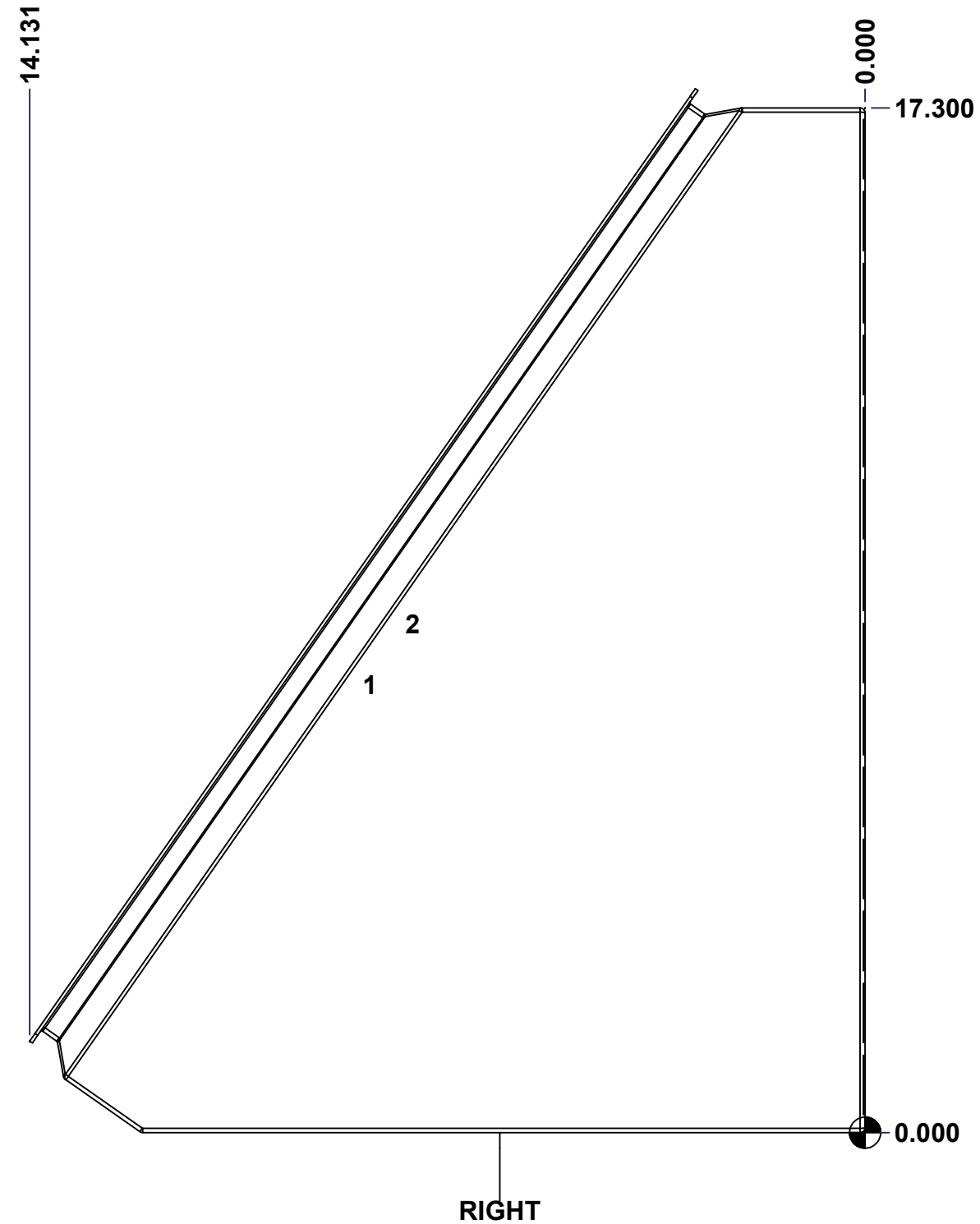

	Description	Status
	1412CSE 20" x 20" x 14.019" Body	(NULL)
	Part Number Numéro Pièce	Rev.
	1412CSE202013B	0
		3 / 7

This drawing is confidential and must not be reproduced or used without the consent of EXM

Ce dessin est confidentiel et ne doit pas être reproduit ou utilisé sans le consentement de EXM

STANDARD FEATURES ARE NOT LISTED IN THIS HOLE TABLE			
HOLE TABLE - LEFT VIEW (CUSTOM FEATURE ONLY)			
CUT-OUT	XDIM	YDIM	DESCRIPTION
1	8.457	7.560	STUDSM5 x 12mm (Inside)
2	7.734	8.592	STUDSM5 x 12mm (Inside)

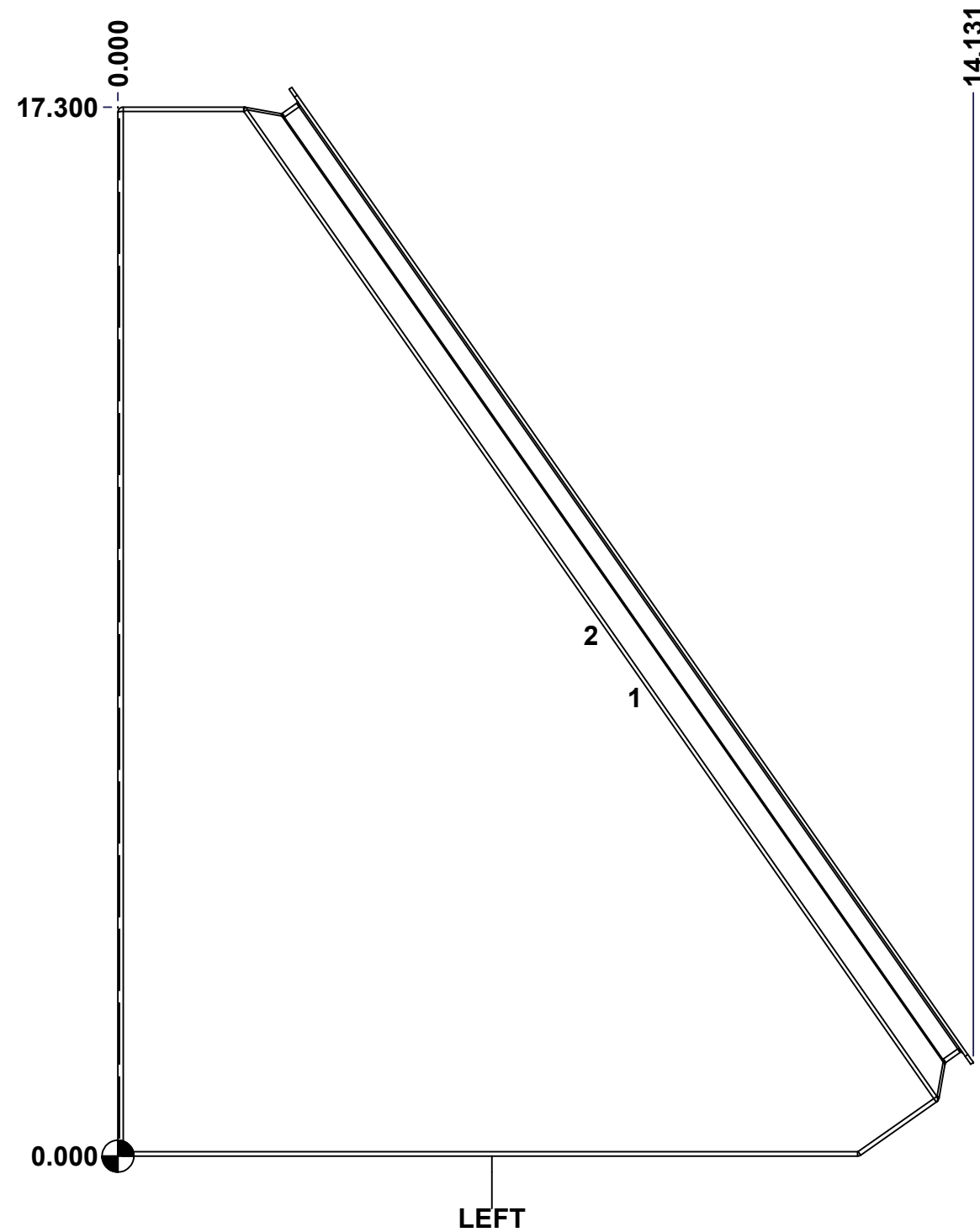

	Description	Status	
	1412CSE 20" x 20" x 14.019" Body	(NULL)	
	Part Number Numéro Pièce	Rev.	5
	1412CSE202013B	0	7

This drawing is confidential and must not be reproduced or used without the consent of EXM

Ce dessin est confidentiel et ne doit pas être reproduit ou utilisé sans le consentement de EXM

STANDARD FEATURES ARE NOT LISTED IN THIS HOLE TABLE			
HOLE TABLE - ANGLE VIEW (CUSTOM FEATURE ONLY)			
CUT-OUT	XDIM	YDIM	DESCRIPTION
1	19.125	0.742	STANDOFF M6 x 10mm (Inside)

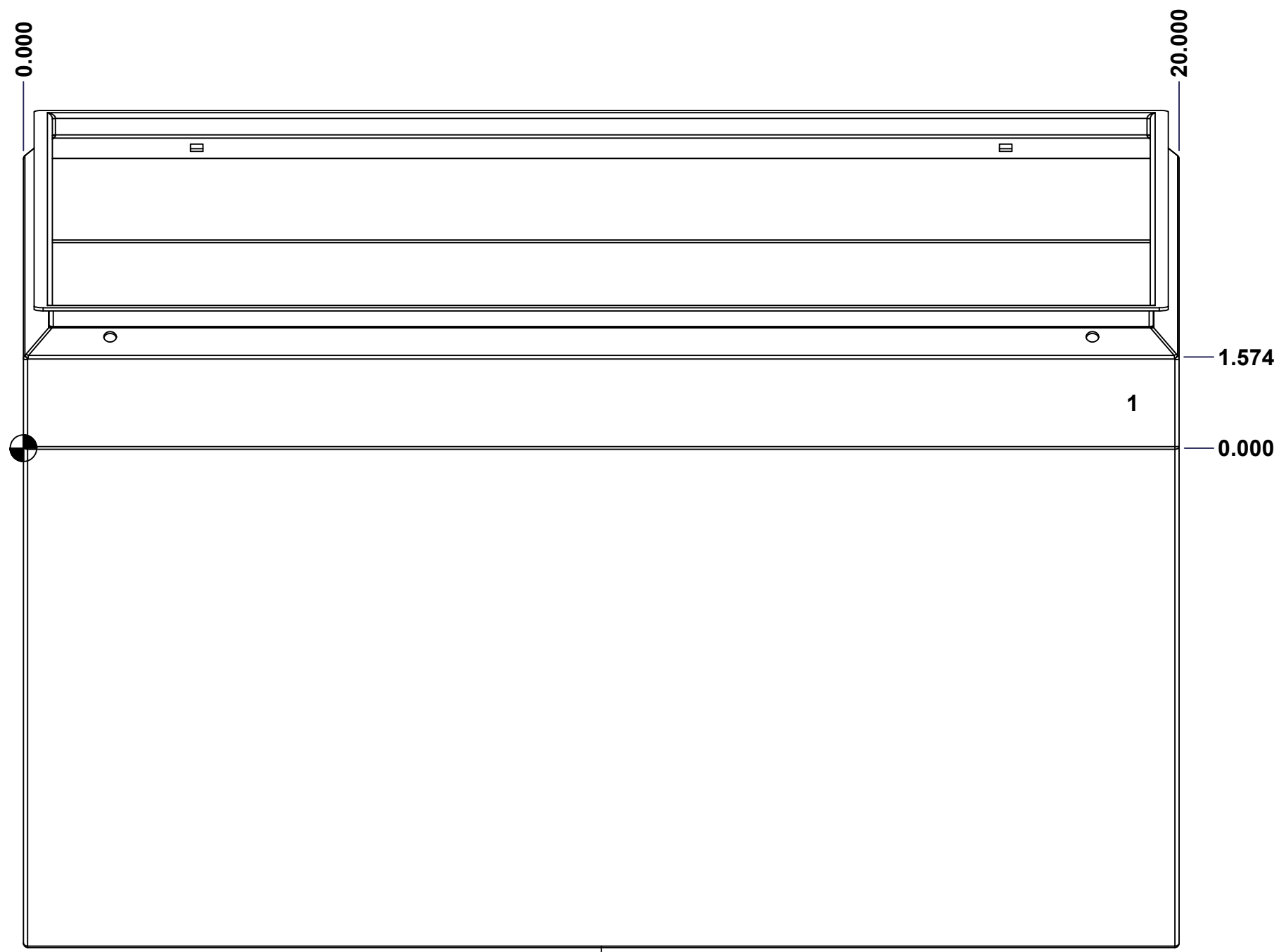

ANGLE

	Description 1412CSE 20" x 20" x 14.019" Body		Status (NULL)
	Part Number Numéro Pièce 1412CSE202013B		Rev. 4 0 / 7

This drawing is confidential and must not be reproduced or used without the consent of EXM

Ce dessin est confidentiel et ne doit pas être reproduit ou utilisé sans le consentement de EXM

No.	Revisions	Date	By/Par

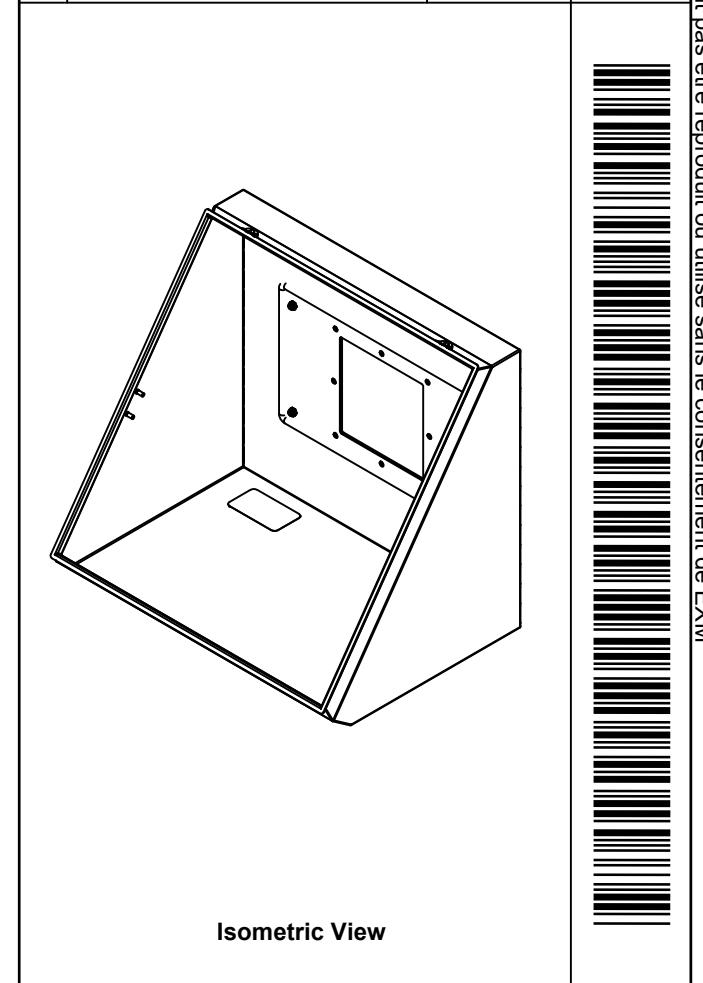

 Tél: (450) 979-4373
 Fax: (450) 979-4626
www.exmweb.com

Flatness Aplatissement
 Max 3.0mm
 Projection 

Customer Client _____ Date _____
 Drawn By Dessiné Par BoxCad: BoxCad Date 12/5/2013

Material Matière 16 Ga Cold Rolled A1008 CS Type B (1.4mm)

Color Couleur Asa-61 Grey Finish Fini Smooth

Description 1412CSE 20" x 20" x 14.019" Body
 Detail Rev. _____

Part Number Numéro Pièce **1412CSE202013B**
 Rev. **0** / 7

4	STUD_M5 x 12mm	0	Stud M5 x 12mm
1	STK-Q-08350	5	Standoff M6 x 10mm
1	STK-P-02400S	0	Powder Paint (Asa-61 Grey / Smooth)
1	STK-S-00100	0	3.5" x 2" Silver Milar Flexcon Sticker
1	1412CSE202013B-P	0	1412CSE 20" x 20" x 14.019" Body Part
1	1500CS_SUP	0	1500CS - Support Plate Part
2	STK-A-70469	6	5412 ESSMCH - Stainless Steel 316 Body Catch Assembly
2	STK-Q-08100	1	M5 Nylon Insert Lock Nut
Qty	Part_Number	Rev	Description
Parts List			

This drawing is confidential and must not be reproduced or used without the consent of EXM

Ce dessin est confidentiel et ne doit pas être reproduit ou utilisé sans le consentement de EXM

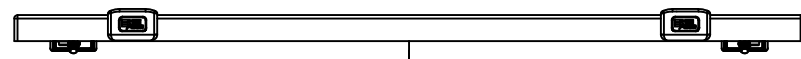

TOP

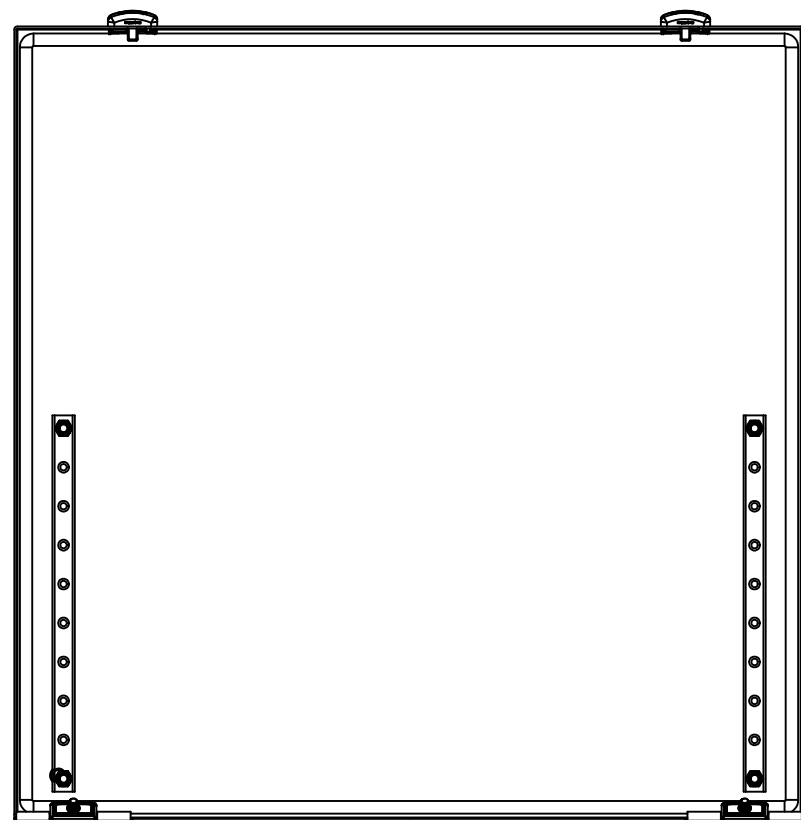

BACK

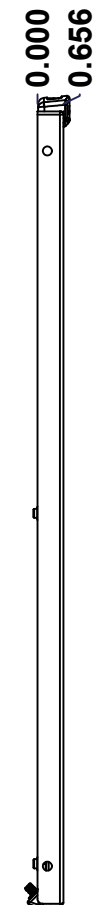

LEFT

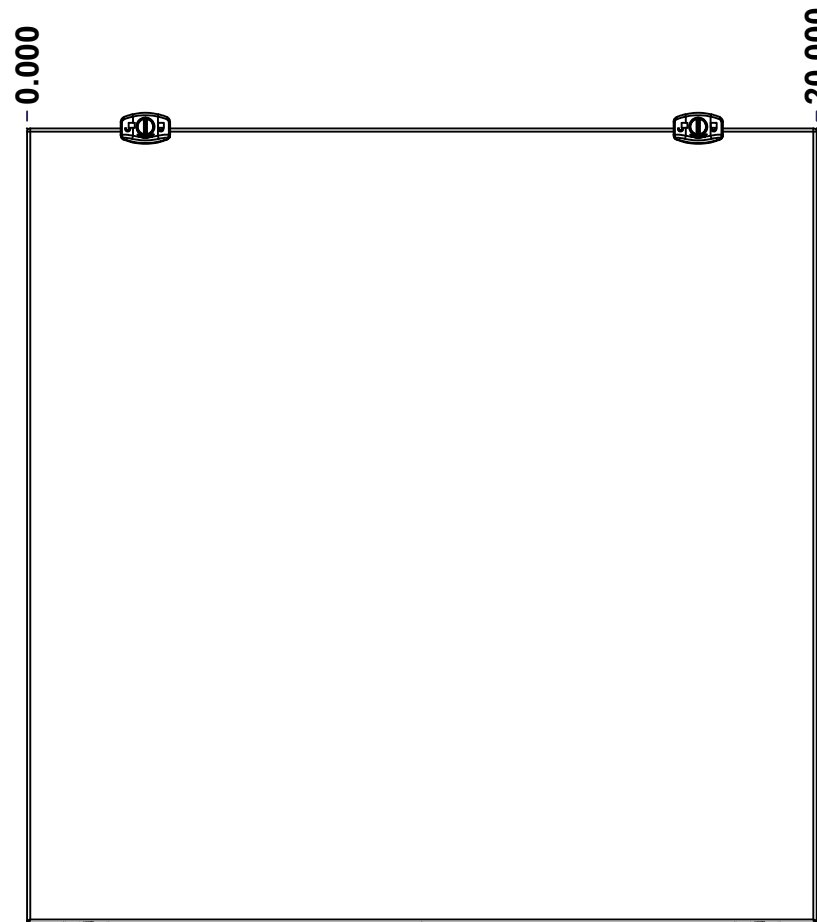

FRONT

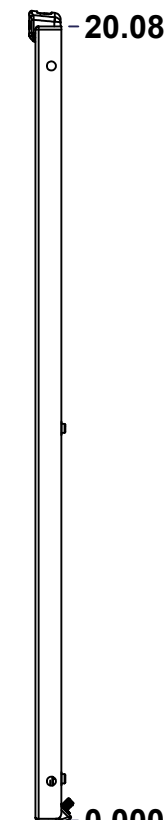

RIGHT



BOTTOM

No.	Revisions	Date	By/Par

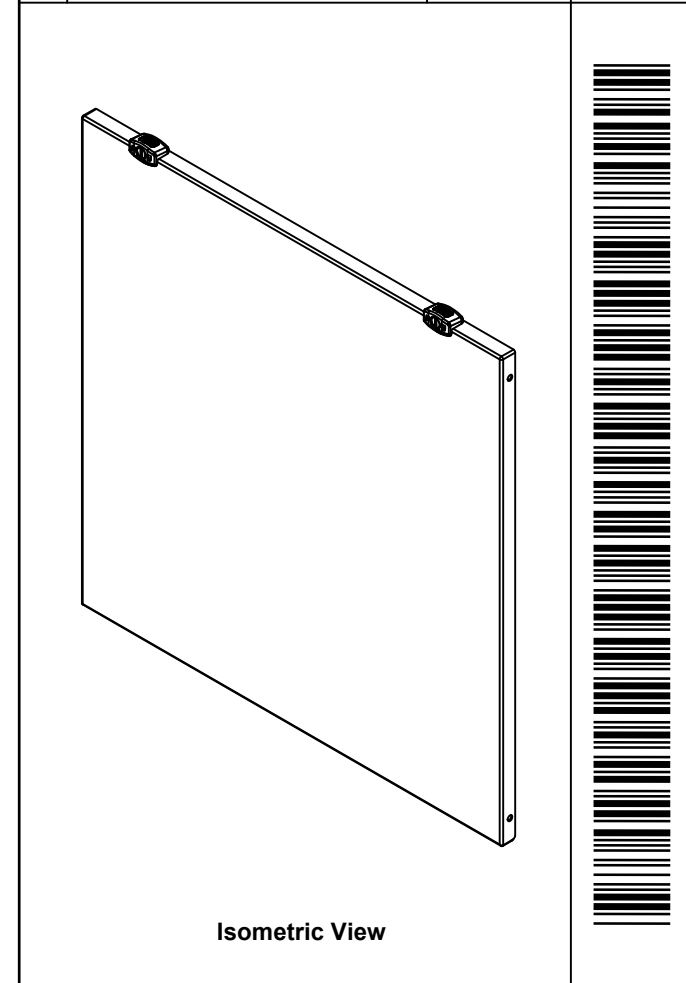

Isometric View

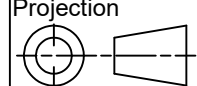
 Tél: (450) 979-4373 Fax: (450) 979-4626 www.exmweb.com		Flatness Aplatissement Max 3.0mm Projection 
Customer Client	Date	
Drawn By Dessiné Par	BoxCad: BoxCad	Date 12/5/2013
Material Matière	16 Ga Cold Rolled A1008 CS Type B (1.4mm)	
Color Couleur	Asa-61 Grey	Finish Finis Smooth
Description	Detail Rev.	
1412CSE 20" x 20" Cover		
Part Number Numéro Pièce	Rev. 0	1 / 3
1412CSE202013C		

SEE BILL OF MATERIAL ON LAST PAGE

This drawing is confidential and must not be reproduced or used without the consent of EXM

Ce dessin est confidentiel et ne doit pas être reproduit ou utilisé sans le consentement de EXM

STANDARD FEATURES ARE NOT LISTED IN THIS HOLE TABLE			
HOLE TABLE - FRONT VIEW (CUSTOM FEATURE ONLY)			
CUT-OUT	XDIM	YDIM	DESCRIPTION
1	18.875	1.145	STANDOFF M6 x 10mm (Inside)
2	3.000	20.080	LOCK 880 SCQ2MS @ 90.0°
3	17.000	20.080	LOCK 880 SCQ2MS @ 90.0°
4	1.250	1.062	STUDS M6 x 18mm (Inside)
5	1.250	9.920	STUDS M6 x 18mm (Inside)
6	18.750	1.062	STUDS M6 x 18mm (Inside)
7	18.750	9.920	STUDS M6 x 18mm (Inside)

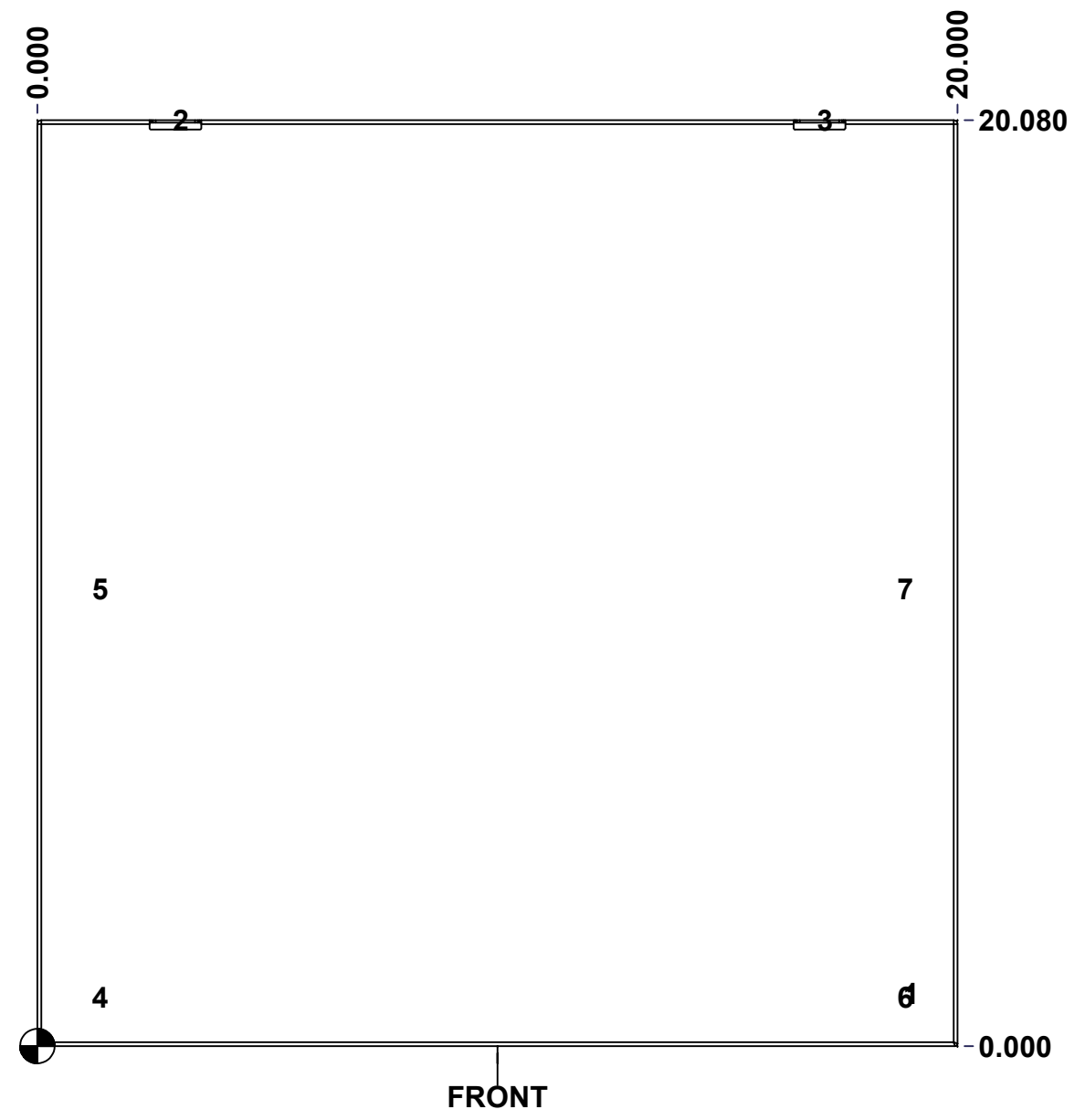

	Description	Status	
	1412CSE 20" x 20" Cover	(NULL)	
	Part Number Numéro Pièce	Rev.	
	1412CSE202013C	0	2 3

This drawing is confidential and must not be reproduced or used without the consent of EXM

Ce dessin est confidentiel et ne doit pas être reproduit ou utilisé sans le consentement de EXM

No.	Revisions	Date	By/Par

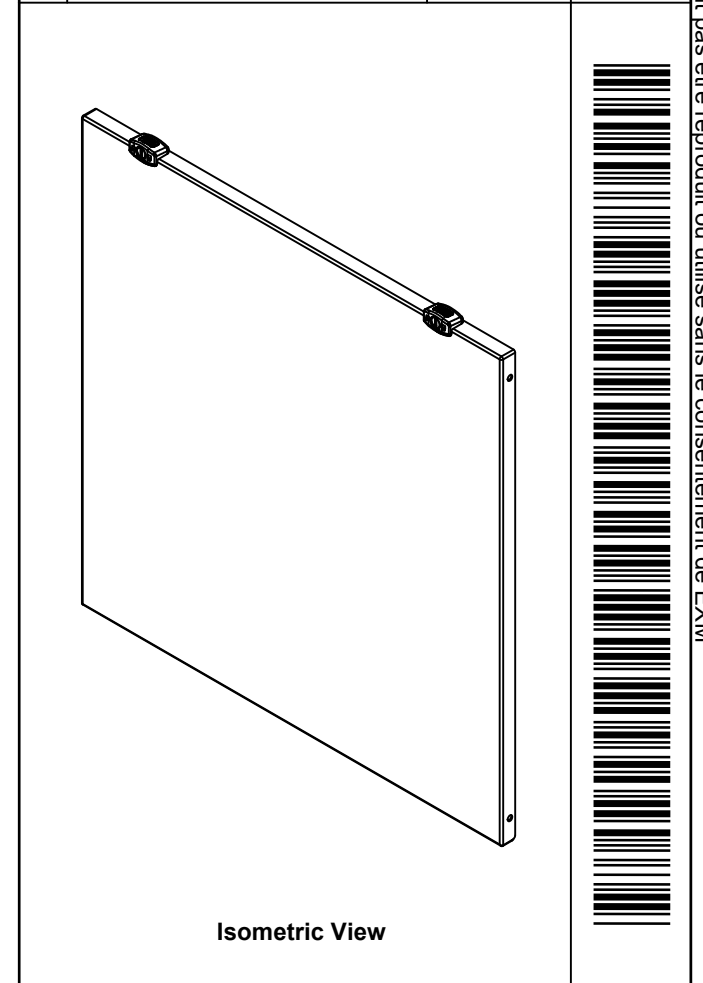

 Tél: (450) 979-4373
 Fax: (450) 979-4626
www.exmweb.com

Flatness
 Aplatissement
 Max 3.0mm
Projection

Customer Client _____ Date _____
 Drawn By Dessiné Par BoxCad: BoxCad Date 12/5/2013

Material Matière 16 Ga Cold Rolled A1008 CS Type B (1.4mm)

Color Couleur Asa-61 Grey Finish Fini Smooth

Description 1412CSE 20" x 20" Cover Detail Rev. _____

Part Number Numéro Pièce **1412CSE202013C** Rev. **0** 3

Qty	Part Name	Rev	Description
4	STK-Q-16055	1	M6 x 18mm Stud (No Paint Cap Required)
1	STK-Q-08350	5	Standoff M6 x 10mm
1	STK-P-02400S	0	Powder Paint (Asa-61 Grey / Smooth)
2	STK-Q-46020-12	5	5412 ES Vertical Door Stiffener 12"
1	1412CSE202013G	0	1412CSE 20" x 20" Gasket
1	1412CSE202013C-P	0	1412CSE 20" x 20" Cover Part
2	880SCQ2S	3	5412 ESMCH - External Lock Assy - Slot Lock
2	STK-A-33033	4	5412 ESMCH Hinge
4	STK-Q-07220	1	M6 Nylon Insert Lock Nut
Parts List			