

All knockouts are actual size

Les disques défonçables sont grandeur réel

This drawing is confidential and must not be reproduced or used without the consent of EXM

Ce dessin est confidentiel et ne doit pas être reproduit ou utilisé sans le consentement de EXM

No.	Revisions	Date	By/Par

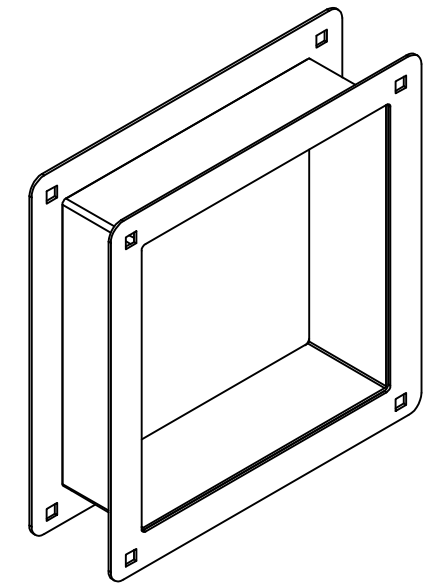
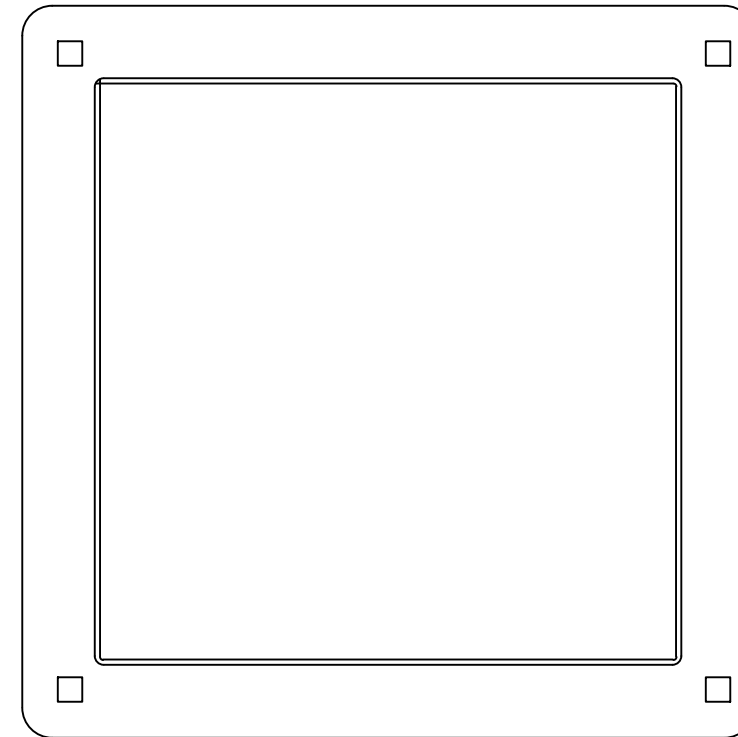
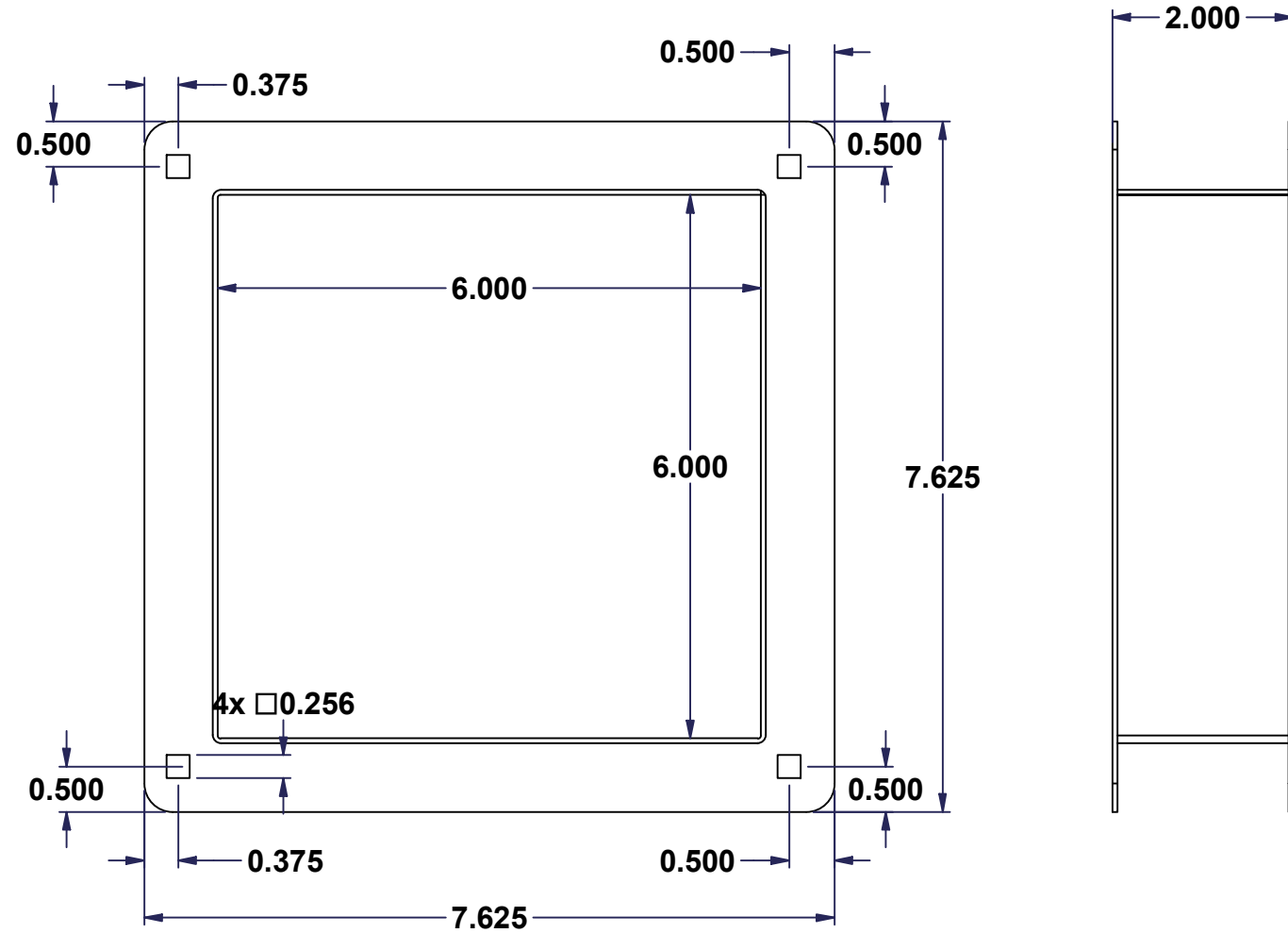

Isometric View



Tél: (450) 979-4373
 Fax: (450) 979-4626
 www.exmweb.com

Flatness
Aplatissement

Max 3.0mm

Projection

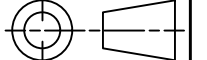

Customer Client	Date
Drawn By / Dessiné Par: ZinH	Date: 2022/10/14
Material / Matière	See Part List
Color / Couleur	See Part List
Finish / Fini	See Part List
Description	Detail Rev.

Parts List							
Item	Qty	Part Number	Rev.	Description	Material	Color	Finish
1	1	1412NS6002B	0	6 x 6 x 2 Nipple body	16 Ga H.R.P. & O.	Asa-61 Grey	Smooth
2	2	1412NS6002FL	0	1412NS6002FL	16 Ga H.R.P. & O.	Asa-61 Grey	Smooth

6 x 6 x 2 Nipple		Rev.	1
Part Number / Numéro Pièce: 1412NS6002		Rev.	0