

This drawing is confidential and must not be reproduced or used without the consent of EXM

Ce dessin est confidentiel et ne doit pas être reproduit ou utilisé sans le consentement de EXM

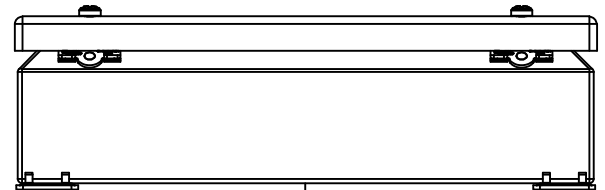

TOP

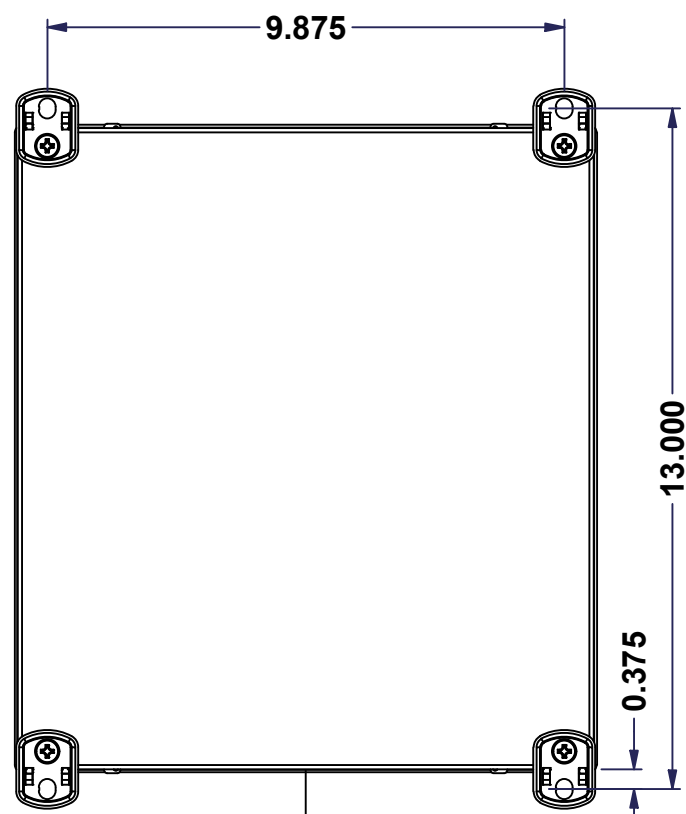

BACK

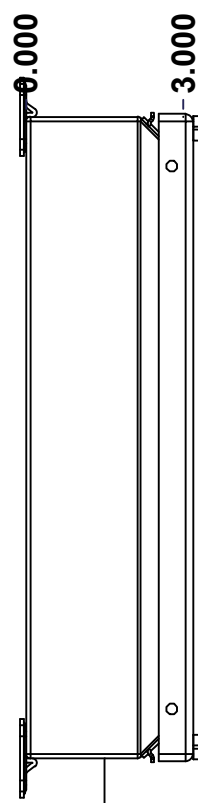

LEFT

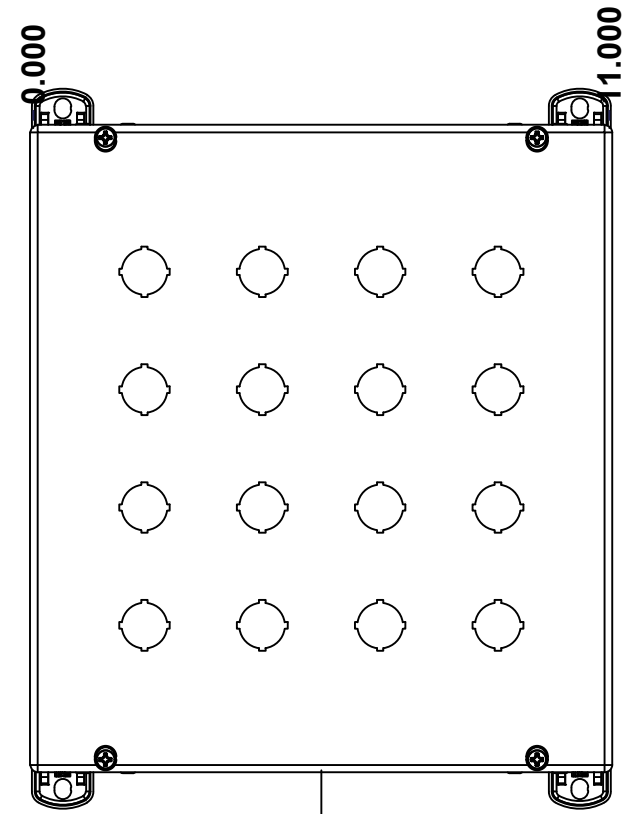

FRONT

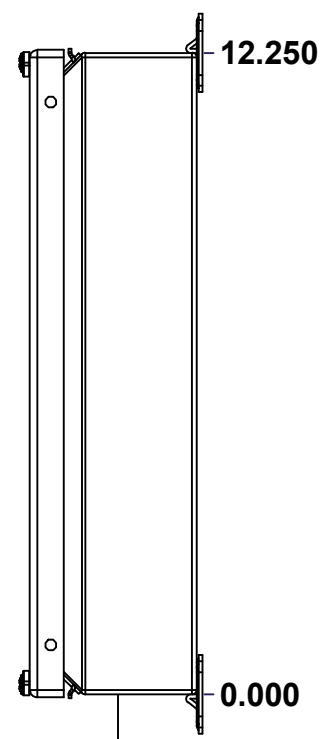

RIGHT

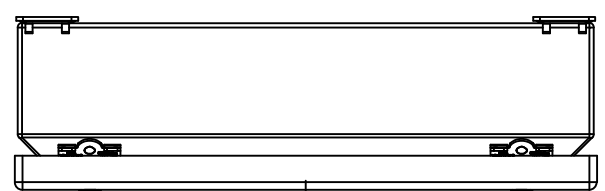

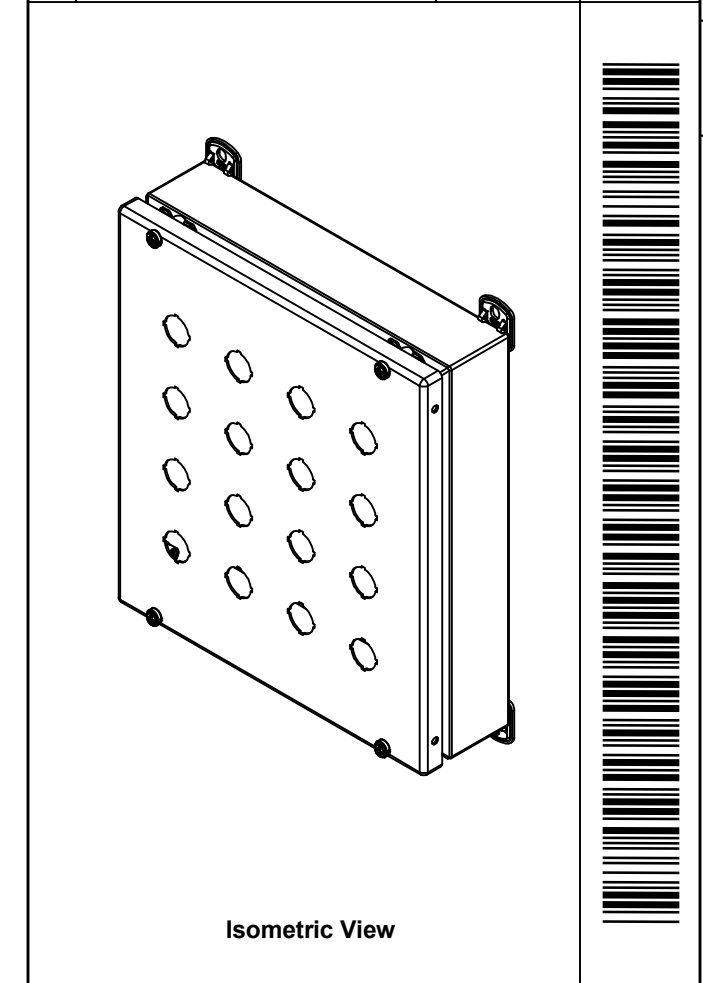

BOTTOM

No.	Revisions	Date	By/Par
0.1	Update with boxcad	2022/5/11	Zin

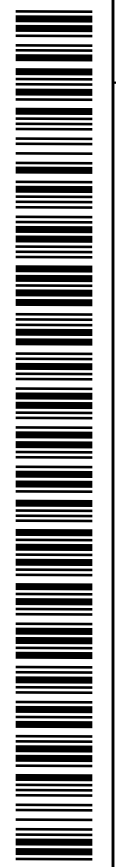

Isometric View

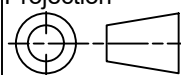

 Tél: (450) 979-4373 Fax: (450) 979-4626 www.exmweb.com	Flatness Aplatissement Max 3.0mm
	Projection 
Customer Client	Date
Drawn By Dessiné Par BoxCad: Zin	Date 5/10/2022
Material Matière 16 Ga Cold Rolled A1008 CS Type B (1.4mm)	
Color Couleur Asa-61 Grey	Finish Fini Smooth
Description 1412SDMN 12.25" x 11" x 3" Assembly	
Part Number Numéro Pièce 1412SD111003MN	Detail Rev. Rev. 1 0

SEE BILL OF MATERIAL ON LAST PAGE

This drawing is confidential and must not be reproduced or used without the consent of EXM

Ce dessin est confidentiel et ne doit pas être reproduit ou utilisé sans le consentement de EXM

NOTE	
ITEM	DESCRIPTION
1	NEMA 4/12 Enclosure
2	C/W Standard ground standoffs on box and cover
3	W/O Standard door stiffener
4	W/O Inner panel
5	W/O Inner panel mounting standoffs

No.	Revisions	Date	By/Par
0.1	Update with boxcad	2022/5/11	Zin

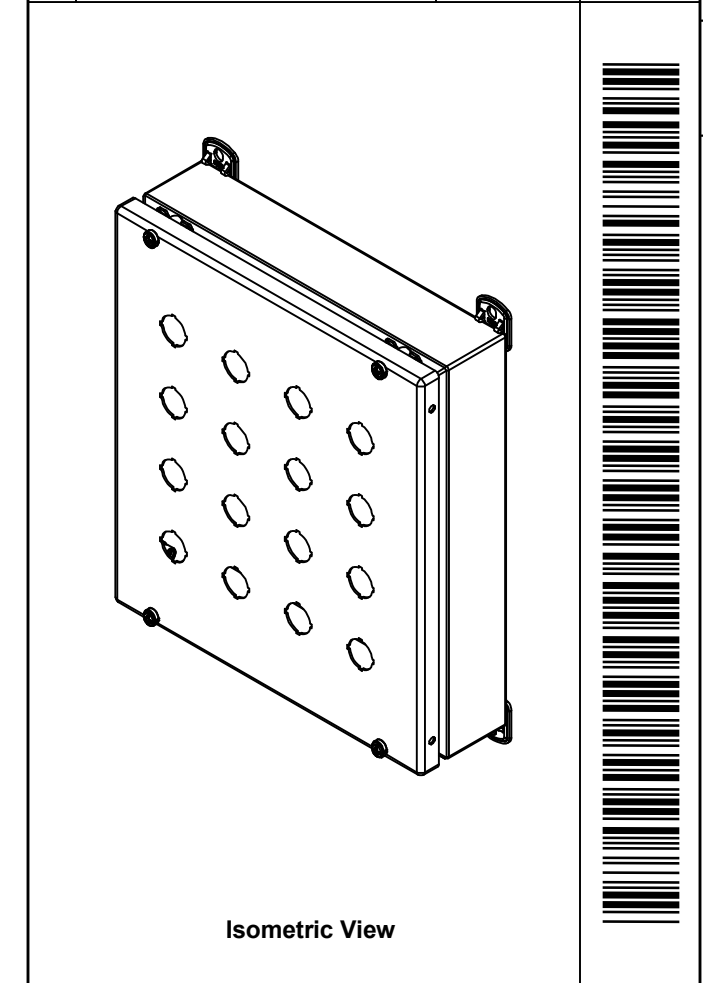

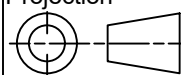
 Tél: (450) 979-4373 Fax: (450) 979-4626 www.exmweb.com		Flatness Aplatissement Max 3.0mm Projection 
Customer Client	Date	
Drawn By Dessiné Par	BoxCad: Zin	Date 5/10/2022
Material Matière	16 Ga Cold Rolled A1008 CS Type B (1.4mm)	
Color Couleur	Asa-61 Grey	Finish Fini Smooth
Description		Detail Rev.
1412SDMN 12.25" x 11" x 3" Assembly		
Part Number Numéro Pièce	1412SD111003MN	Rev. 2
		0

PACKING		
ITEM	QTY	DESCRIPTION
Cardboard sleeve	2	Top and Bottom
Cardboard strip	2	Between back of enclosure and inner panel
Plastic bag	1	To protect cover surface and inside gasket
Plastic strap - Black	2	To Squeeze the 2 cardboard sleeve together
Packaging label	1	White label with product number

Qty	Part Number	Rev	Description
1	STK-K-02920	3	5412 ESSC Accessory Kit
1	1412SD111003MNC	0	1412SDMN 12.25" x 11" Cover
1	1412SD111003MNB	0	1412SDMN 12.25" x 11" x 3" Body
Parts List			

This drawing is confidential and must not be reproduced or used without the consent of EXM

Ce dessin est confidentiel et ne doit pas être reproduit ou utilisé sans le consentement de EXM

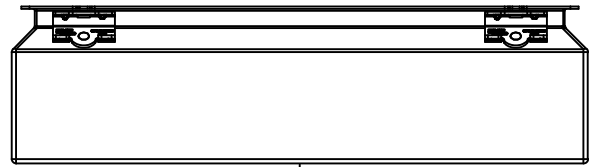

TOP

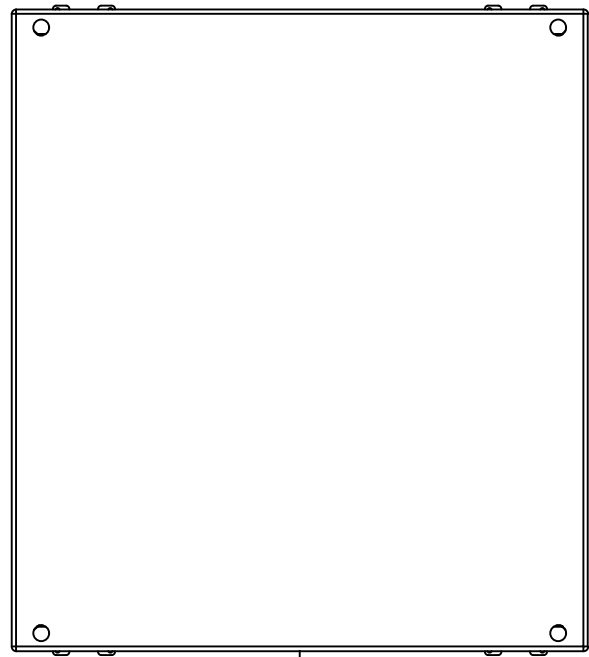

BACK

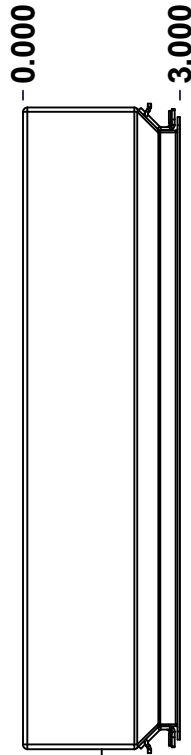

LEFT

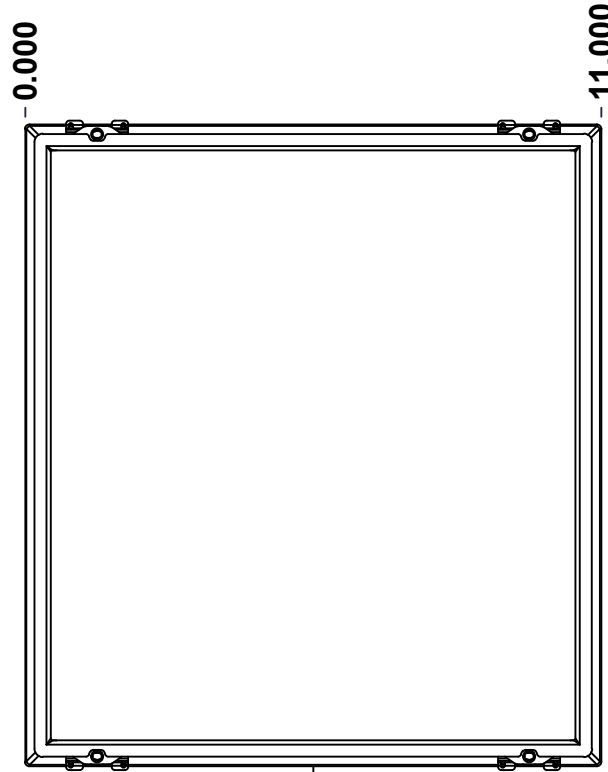

FRONT

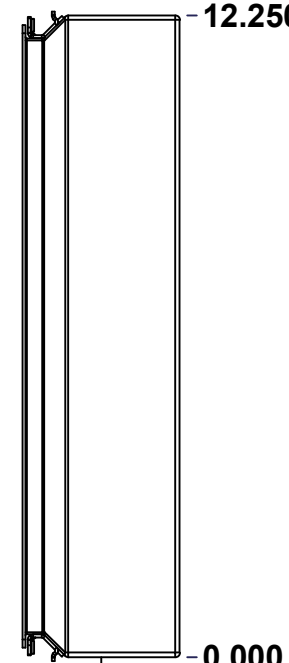

RIGHT

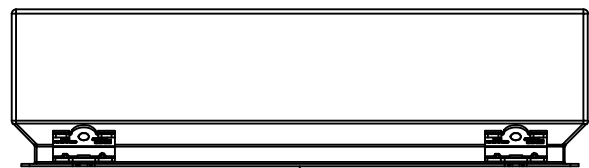

BOTTOM

No.	Revisions	Date	By/Par
0.1	Update with boxcad	2022/5/11	Zin

Isometric View

Tél: (450) 979-4373 Fax: (450) 979-4626 www.exmweb.com		Flatness Aplatissement	
		Max 3.0mm	
Customer Client		Date	
Drawn By Dessiné Par BoxCad: Zin		Date 5/10/2022	
Material Matière 16 Ga Cold Rolled A1008 CS Type B (1.4mm)			
Color Couleur Asa-61 Grey		Finish Fini Smooth	
Description 1412SDMN 12.25" x 11" x 3" Body			Detail Rev.
Part Number Numéro Pièce 1412SD111003MNB		Rev. 0	1 / 7

SEE BILL OF MATERIAL ON LAST PAGE

This drawing is confidential and must not be reproduced or used without the consent of EXM

STANDARD FEATURES ARE NOT LISTED IN THIS HOLE TABLE

Ce dessin est confidentiel et ne doit pas être reproduit ou utilisé sans le consentement de EXM



	Description		Status
	1412SDMN 12.25" x 11" x 3" Body		(NULL)
Part Number Numéro Pièce		Rev.	2
1412SD111003MNB		0	7

This drawing is confidential and must not be reproduced or used without the consent of EXM

STANDARD FEATURES ARE NOT LISTED IN THIS HOLE TABLE

Ce dessin est confidentiel et ne doit pas être reproduit ou utilisé sans le consentement de EXM

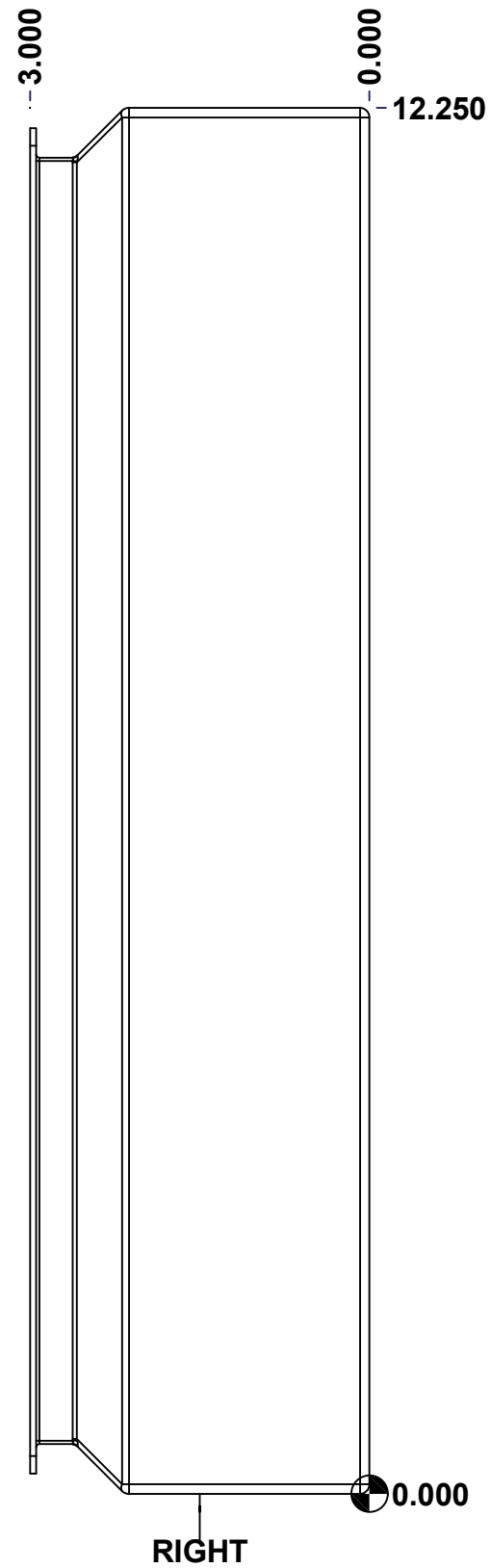

	Description		Status
	1412SDMN 12.25" x 11" x 3" Body		(NULL)
Part Number Numéro Pièce		Rev.	
1412SD111003MNB		0	3 7

This drawing is confidential and must not be reproduced or used without the consent of EXM

STANDARD FEATURES ARE NOT LISTED IN THIS HOLE TABLE

Ce dessin est confidentiel et ne doit pas être reproduit ou utilisé sans le consentement de EXM

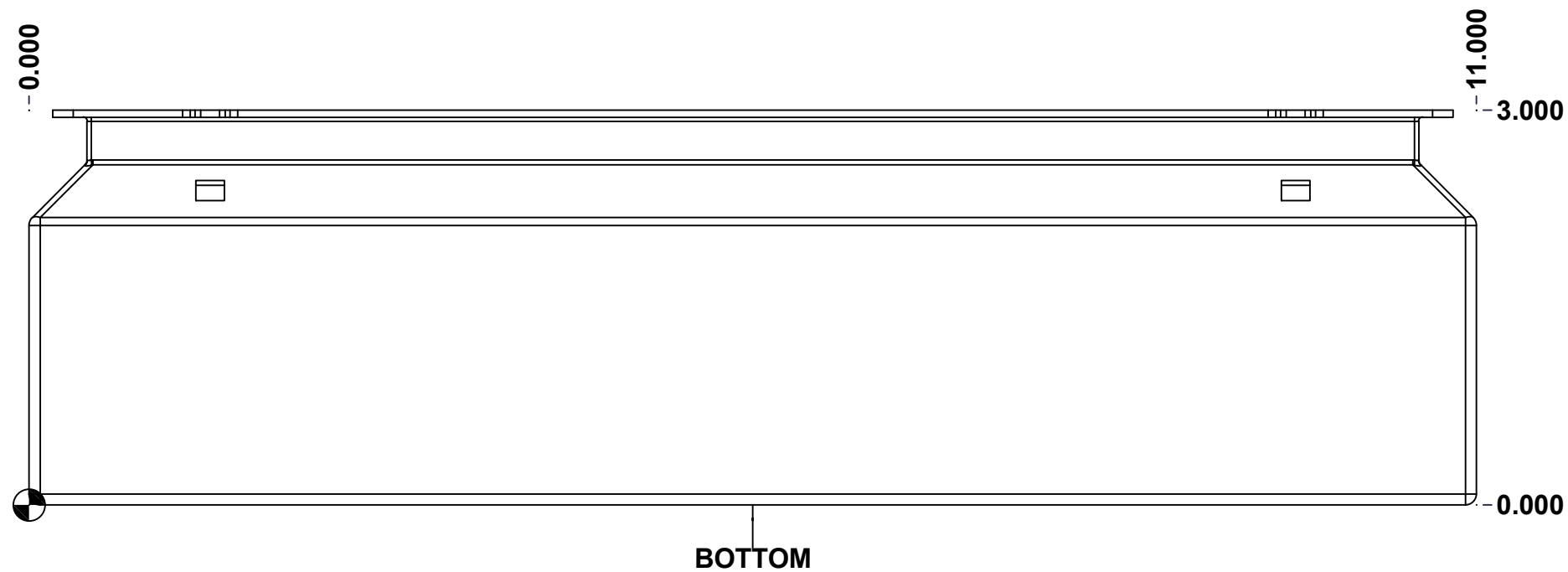

	Description		Status
	1412SDMN 12.25" x 11" x 3" Body		(NULL)
Part Number Numéro Pièce		Rev.	
1412SD111003MNB		0	4 7

This drawing is confidential and must not be reproduced or used without the consent of EXM

Ce dessin est confidentiel et ne doit pas être reproduit ou utilisé sans le consentement de EXM

STANDARD FEATURES ARE NOT LISTED IN THIS HOLE TABLE			
HOLE TABLE - LEFT VIEW (CUSTOM FEATURE ONLY)			
CUT-OUT	XDIM	YDIM	DESCRIPTION
1	1.625	0.875	STANDOFF M6 x 10mm (Inside)

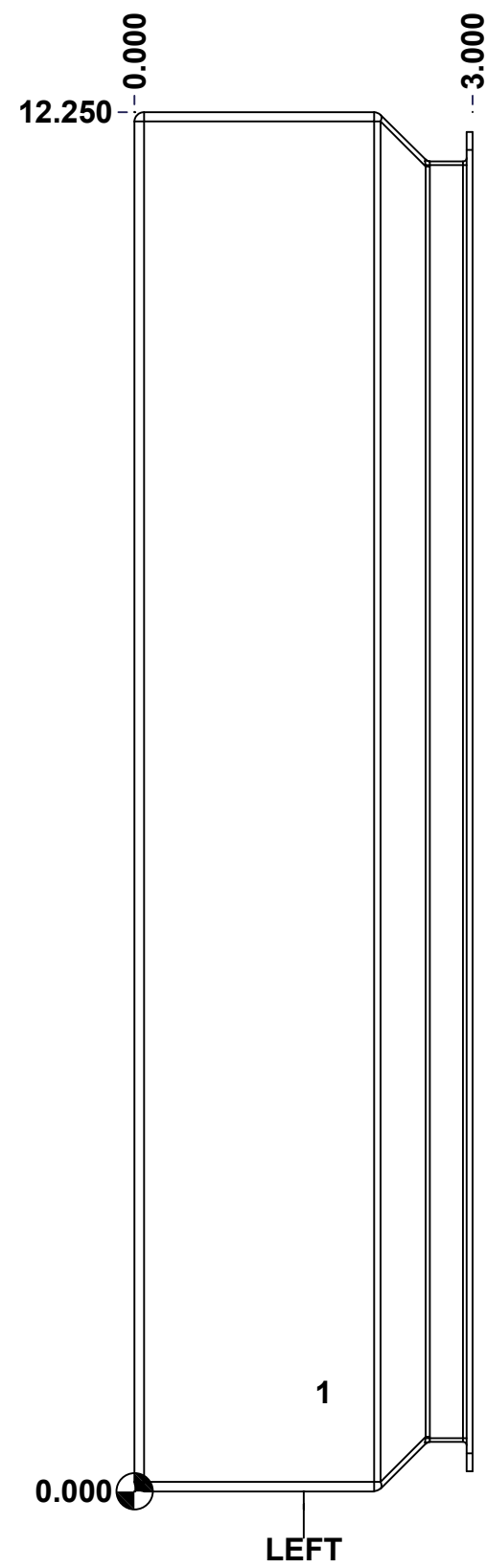

	Description	Status	
	1412SDMN 12.25" x 11" x 3" Body	(NULL)	
	Part Number Numéro Pièce	Rev.	
	1412SD111003MNB	0	5 7

This drawing is confidential and must not be reproduced or used without the consent of EXM

STANDARD FEATURES ARE NOT LISTED IN THIS HOLE TABLE

Ce dessin est confidentiel et ne doit pas être reproduit ou utilisé sans le consentement de EXM

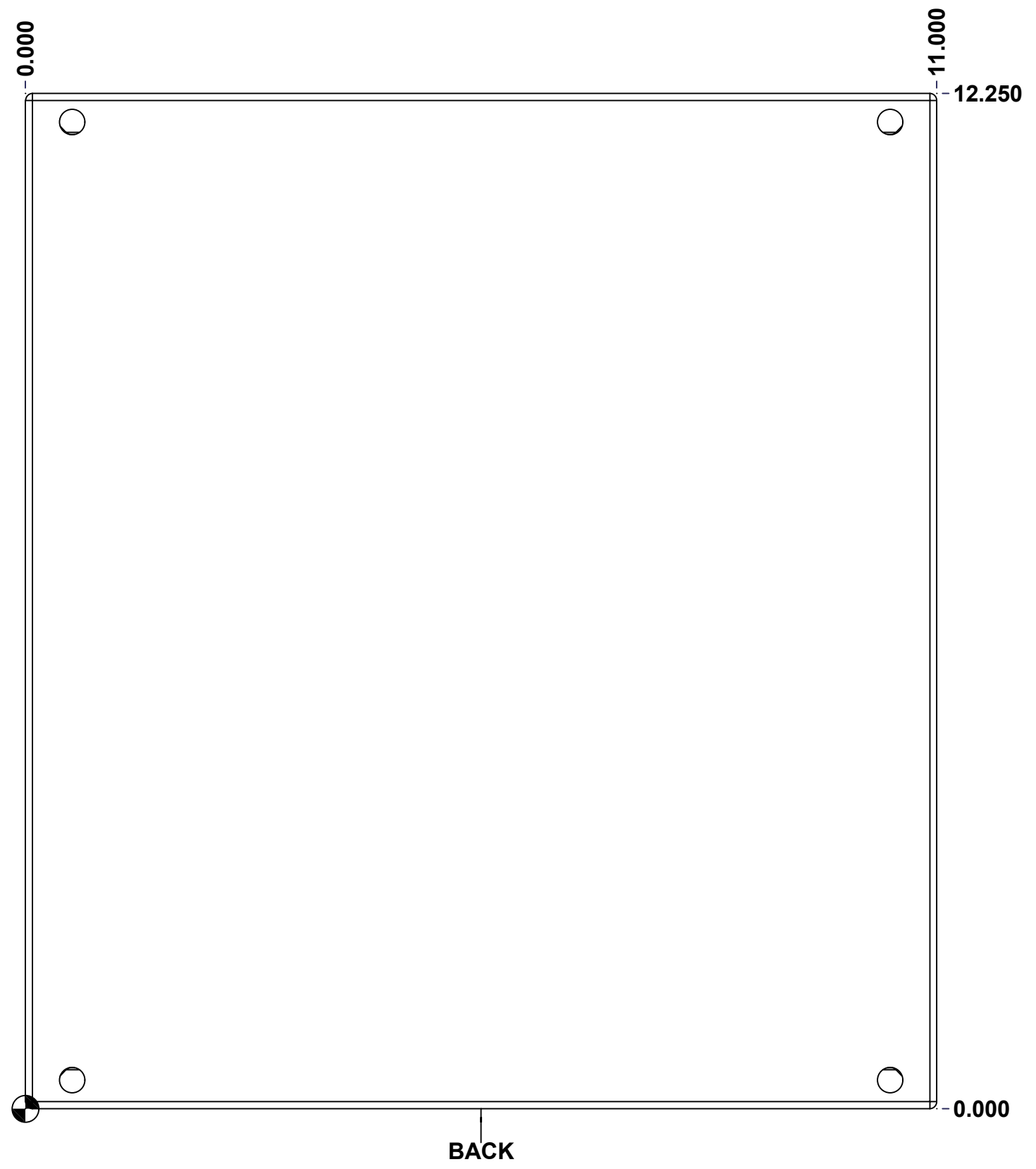



	Description		Status
	1412SDMN 12.25" x 11" x 3" Body		(NULL)
Part Number Numéro Pièce		Rev.	
1412SD111003MNB		0	6 7

This drawing is confidential and must not be reproduced or used without the consent of EXM

Ce dessin est confidentiel et ne doit pas être reproduit ou utilisé sans le consentement de EXM

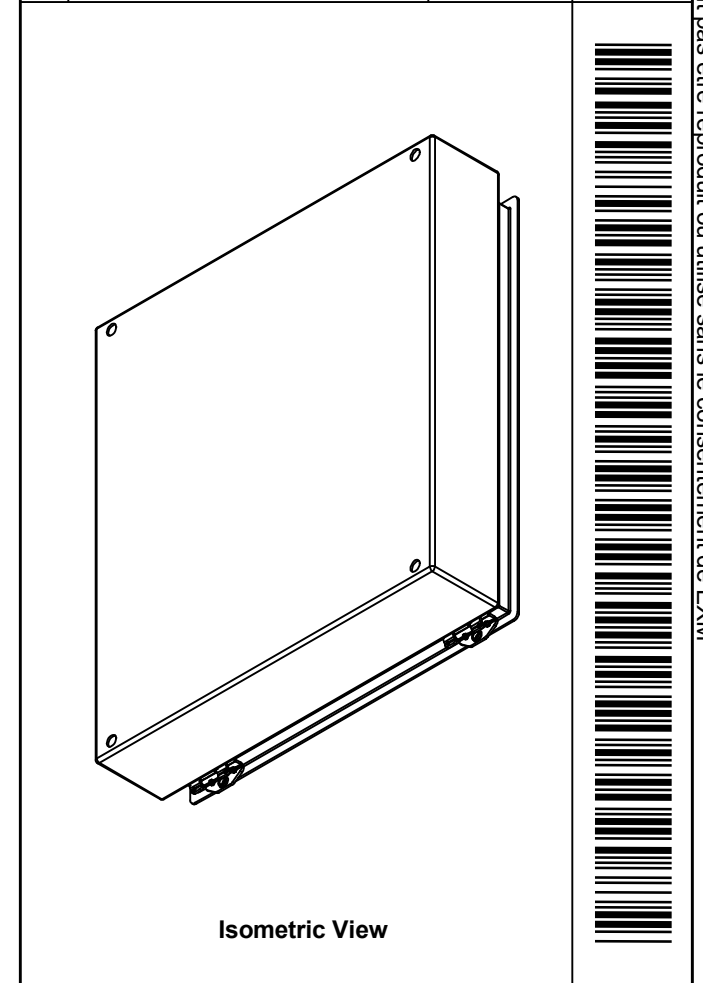
No.	Revisions	Date	By/Par
0.1	Update with boxcad	2022/5/11	Zin

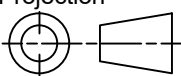

 Tél: (450) 979-4373 Fax: (450) 979-4626 www.exmweb.com		Flatness Aplatissement Max 3.0mm Projection 
Customer Client	Date	
Drawn By / Dessiné Par: BoxCad: Zin	Date: 5/10/2022	
Material / Matière: 16 Ga Cold Rolled A1008 CS Type B (1.4mm)		
Color / Couleur: Asa-61 Grey	Finish / Fini: Smooth	
Description: 1412SDMN 12.25" x 11" x 3" Body		Detail Rev.
Part Number / Numéro Pièce: 1412SD111003MNB	Rev.:	7 / 7

Qty	Part Number	Rev	Description
1	STK-Q-08350	5	Standoff M6 x 10mm
1	STK-P-02400S	0	Powder Paint (Asa-61 Grey / Smooth)
1	1412SD111003MNB-P	0	1412SDMN 12.25" x 11" x 3" Body Part
4	STK-Q-08100	1	M5 Nylon Insert Lock Nut
4	STK-Q-70464	2	5412 ESSC & ESSSC Stainless Steel Body Catch Assembly
Parts List			

This drawing is confidential and must not be reproduced or used without the consent of EXM

Ce dessin est confidentiel et ne doit pas être reproduit ou utilisé sans le consentement de EXM

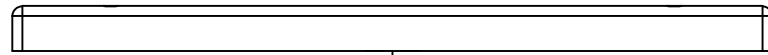

TOP

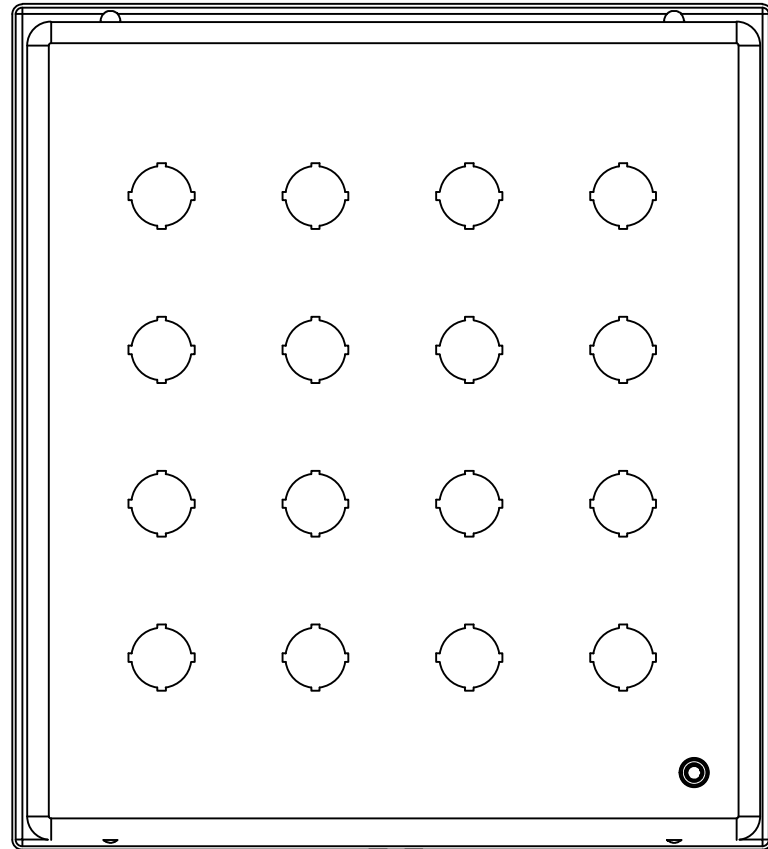

BACK

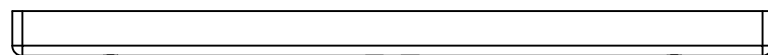

BOTTOM

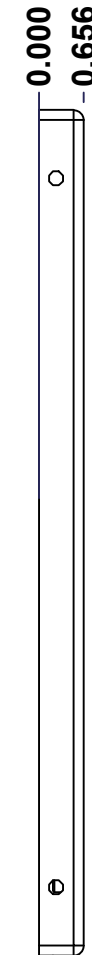

LEFT

0.000
0.656

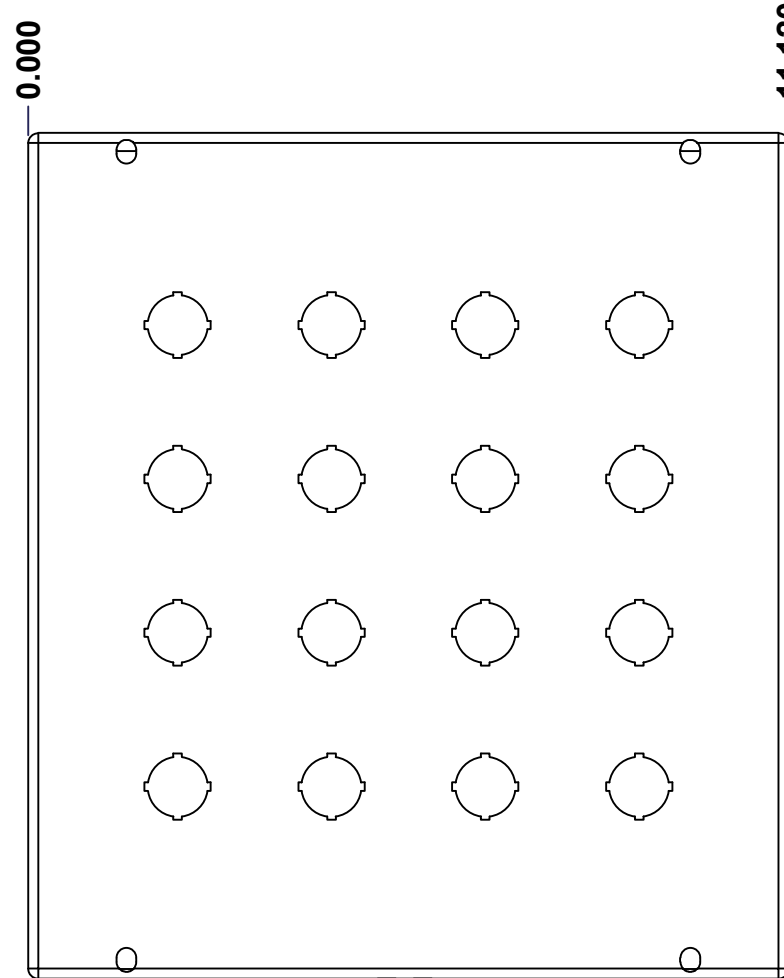

FRONT

0.000
11.120

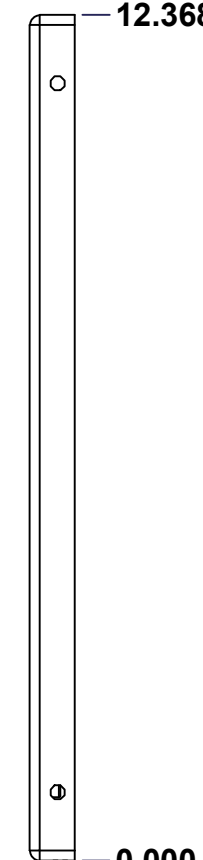

RIGHT

12.368

0.000

No.	Revisions	Date	By/Par
0.1	Update with boxcad	2022/5/11	Zin

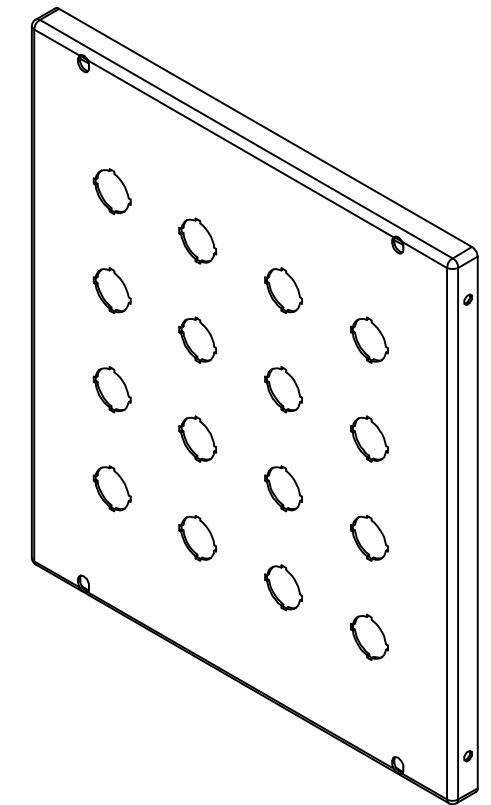

Isometric View



Tél: (450) 979-4373
Fax: (450) 979-4626
www.exmweb.com

Flatness
Aplatissement

Max 3.0mm

Projection

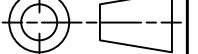

Customer Client	Date
Drawn By Dessiné Par BoxCad: Zin	Date 5/10/2022
Material Matière 16 Ga Cold Rolled A1008 CS Type B (1.4mm)	
Color Couleur Asa-61 Grey	Finish Fini Smooth
Description 1412SDMN 12.25" x 11" Cover	Detail Rev.
Part Number Numéro Pièce 1412SD111003MNC	Rev. 0

SEE BILL OF MATERIAL ON LAST PAGE

This drawing is confidential and must not be reproduced or used without the consent of EXM

Ce dessin est confidentiel et ne doit pas être reproduit ou utilisé sans le consentement de EXM

STANDARD FEATURES ARE NOT LISTED IN THIS HOLE TABLE			
HOLE TABLE - FRONT VIEW (CUSTOM FEATURE ONLY)			
CUT-OUT	XDIM	YDIM	DESCRIPTION
1	8.935	2.809	22.5 mm Miniature Pushbutton
2	8.935	5.059	22.5 mm Miniature Pushbutton
3	8.935	7.309	22.5 mm Miniature Pushbutton
4	8.935	9.559	22.5 mm Miniature Pushbutton
5	6.685	2.809	22.5 mm Miniature Pushbutton
6	6.685	5.059	22.5 mm Miniature Pushbutton
7	6.685	7.309	22.5 mm Miniature Pushbutton
8	6.685	9.559	22.5 mm Miniature Pushbutton
9	4.435	2.809	22.5 mm Miniature Pushbutton
10	4.435	5.059	22.5 mm Miniature Pushbutton
11	4.435	7.309	22.5 mm Miniature Pushbutton
12	4.435	9.559	22.5 mm Miniature Pushbutton
13	2.185	2.809	22.5 mm Miniature Pushbutton
14	2.185	5.059	22.5 mm Miniature Pushbutton
15	2.185	7.309	22.5 mm Miniature Pushbutton
16	2.185	9.559	22.5 mm Miniature Pushbutton
17	1.145	1.125	STANDOFF M6 x 10mm (Inside)

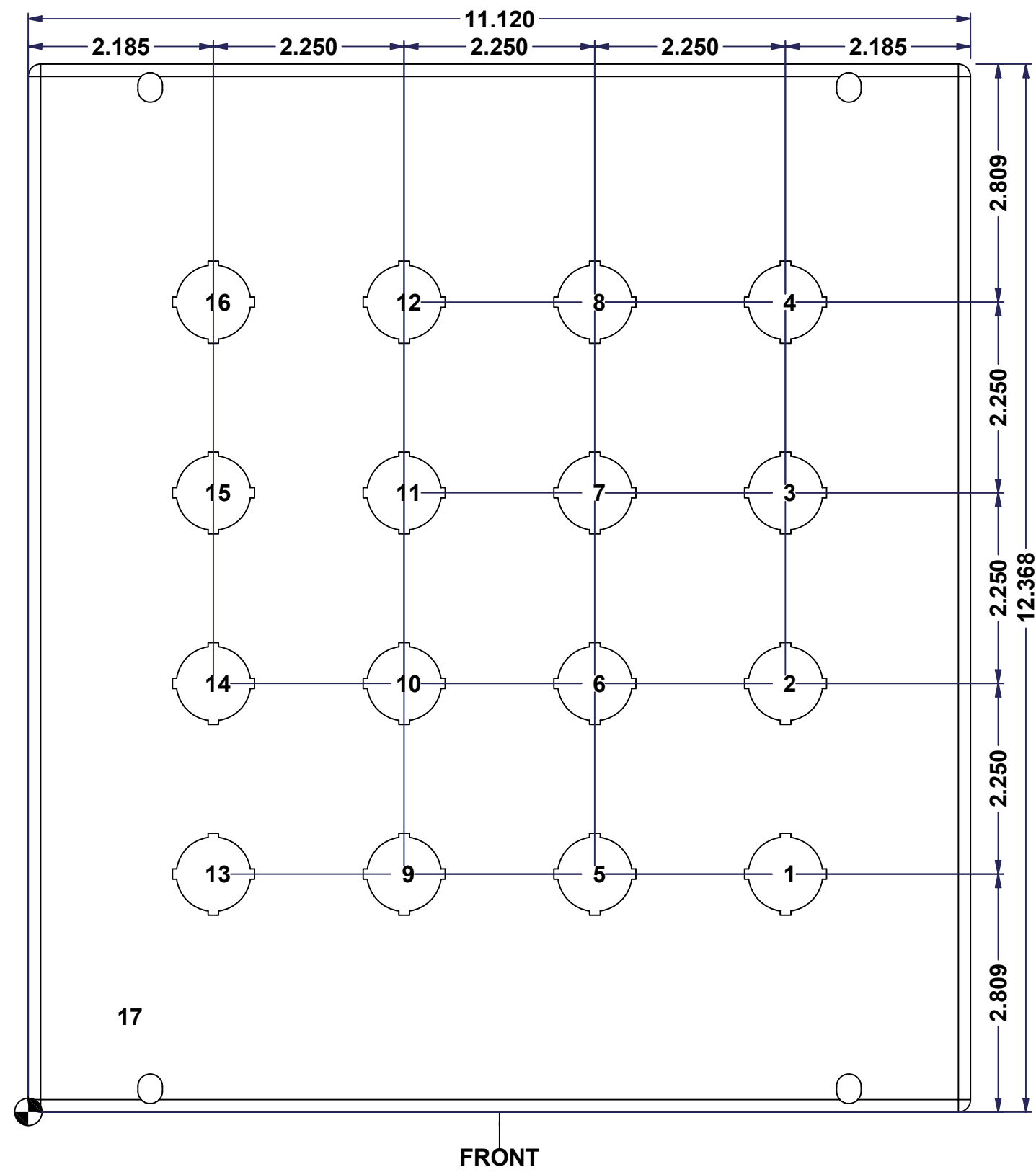

	Description	Status
	1412SDMN 311.2mm x 279.4mm Cover	(NULL)
	Part Number	Rev.
	1412SD111003MNC	2
		3

This drawing is confidential and must not be reproduced or used without the consent of EXM

Ce dessin est confidentiel et ne doit pas être reproduit ou utilisé sans le consentement de EXM

No.	Revisions	Date	By/Par
0.1	Update with boxcad	2022/5/11	Zin

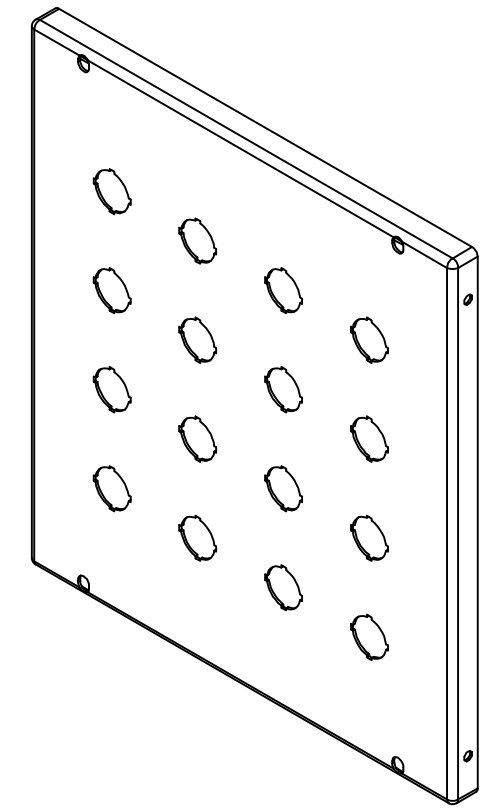

Isometric View

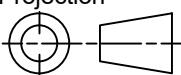

 Tél: (450) 979-4373 Fax: (450) 979-4626 www.exmweb.com		Flatness Aplatissement Max 3.0mm Projection 
Customer Client	Date	
Drawn By / Dessiné Par: BoxCad: Zin	Date: 5/10/2022	
Material / Matière: 16 Ga Cold Rolled A1008 CS Type B (1.4mm)		
Color / Couleur: Asa-61 Grey	Finish / Fini: Smooth	
Description: 1412SDMN 12.25" x 11" Cover		Detail Rev.
Part Number / Numéro Pièce: 1412SD111003MNC	Rev.:	3
		0
		3

Qty	Part Number	Rev	Description
1	STK-Q-08350	5	Standoff M6 x 10mm
1	STK-P-02400S	0	Powder Paint (Asa-61 Grey / Smooth)
1	1412SD111003MNG	0	1412SD 12.25" x 11" Gasket
1	1412SD111003MNC-P	0	1412SDMN 311.2mm x 279.4mm Cover Part
Parts List			