

This drawing is confidential and must not be reproduced or used without the consent of EXM

Ce dessin est confidentiel et ne doit pas être reproduit ou utilisé sans le consentement de EXM

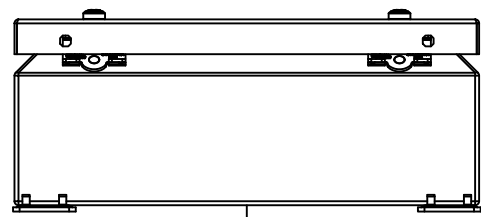

TOP

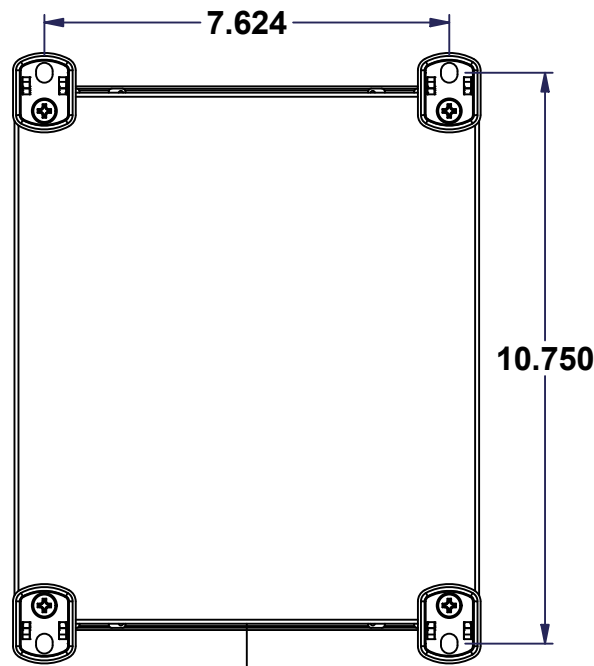

BACK

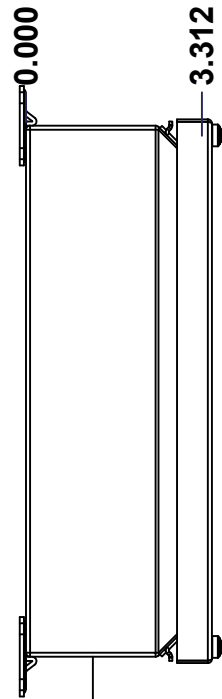

RIGHT

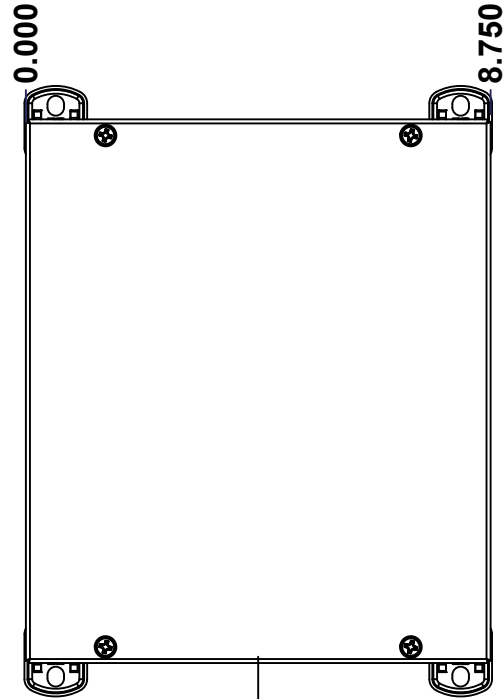

FRONT

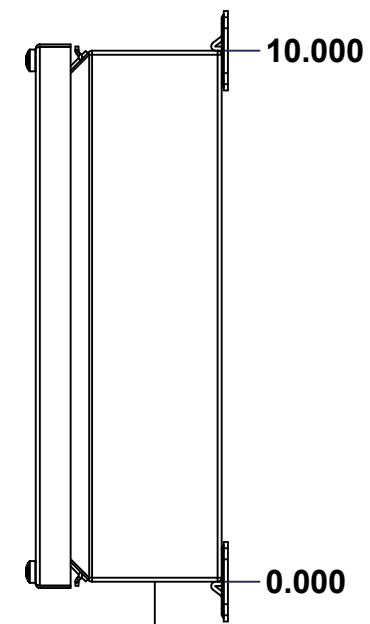

RIGHT

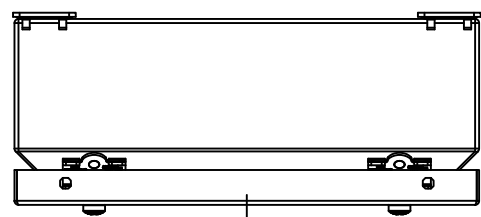

BOTTOM

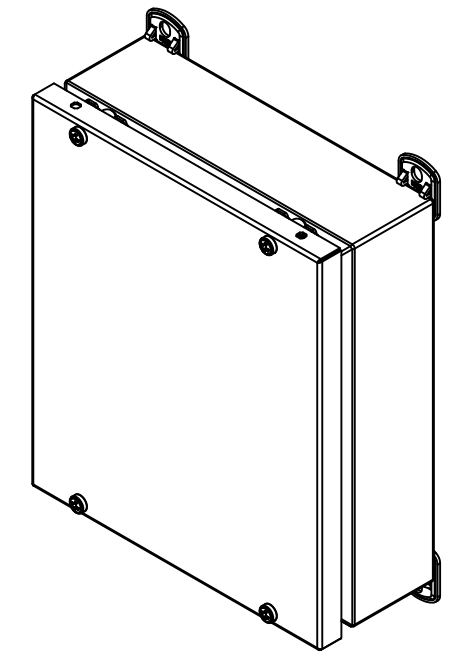

Isometric View

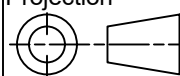

No.	Revisions	Date	By/Par

 Tél: (450) 979-4373 Fax: (450) 979-4626 www.exmweb.com		Flatness Aplatissement Max 3.0mm Projection 
Customer Client	Date	
Drawn By Dessiné Par	BoxCad: Zin	Date 29-Sep-20
Material Matière 18 Ga H.R.P. & O. (1.2mm)		
Color Couleur	Asa-61 Grey	Finish Fini Smooth
Description 1412SDC 10" x 8.75" x 3" Assembly		Detail Rev.
Part Number Numéro Pièce	1412SDC090803	Rev. 1 0

SEE BILL OF MATERIAL ON LAST PAGE

This drawing is confidential and must not be reproduced or used without the consent of EXM

Ce dessin est confidentiel et ne doit pas être reproduit ou utilisé sans le consentement de EXM

NOTE	
ITEM	DESCRIPTION
1	NEMA 4/12 Enclosure
2	C/W Standard ground standoffs on box and cover
3	W/O Standard door stiffener
4	W/O Inner panel
5	W/O Inner panel mounting standoffs

No.	Revisions	Date	By/Par

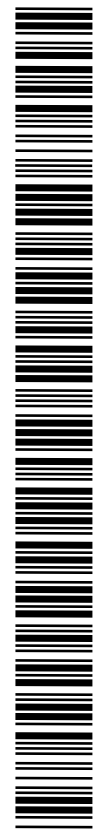
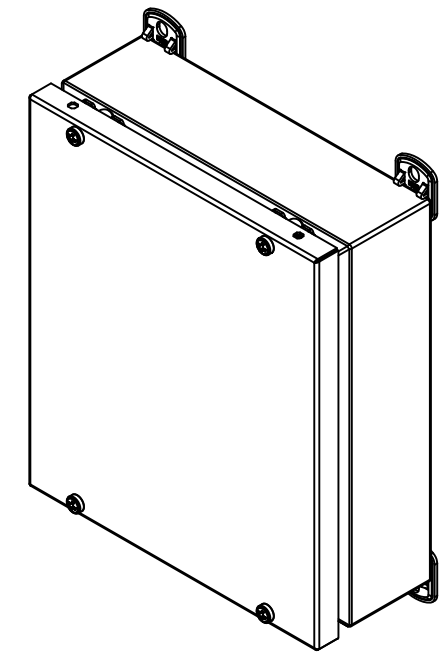

Isometric View



Tél: (450) 979-4373
 Fax: (450) 979-4626
www.exmweb.com

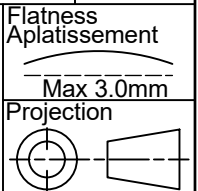

Customer Client	Date
Drawn By / Dessiné Par: BoxCad: Zin	Date: 29-Sep-20
Material / Matière: 18 Ga H.R.P. & O. (1.2mm)	
Color / Couleur: Asa-61 Grey	Finish / Fini: Smooth

PACKING		
ITEM	QTY	DESCRIPTION
Cardboard sleeve	2	Top and Bottom
Cardboard strip	2	Between back of enclosure and inner panel
Plastic bag	1	To protect cover surface and inside gasket
Packaging label	1	White label with product number

Qty	Part Number	Rev	Description
1	1412SDC090803C	0	1412SDC 10" x 8.75" Cover
1	1412SDC090803B	0	1412SDC 10" x 8.75" x 3" Body
Parts List			

Description: 1412SDC 10" x 8.75" x 3" Assembly		Detail Rev.	
Part Number / Numéro Pièce: 1412SDC090803		Rev.:	2
		0	2

This drawing is confidential and must not be reproduced or used without the consent of EXM

Ce dessin est confidentiel et ne doit pas être reproduit ou utilisé sans le consentement de EXM

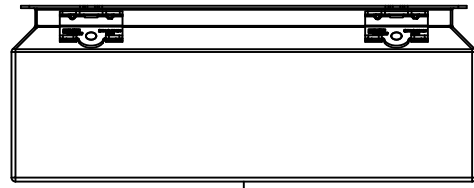

TOP

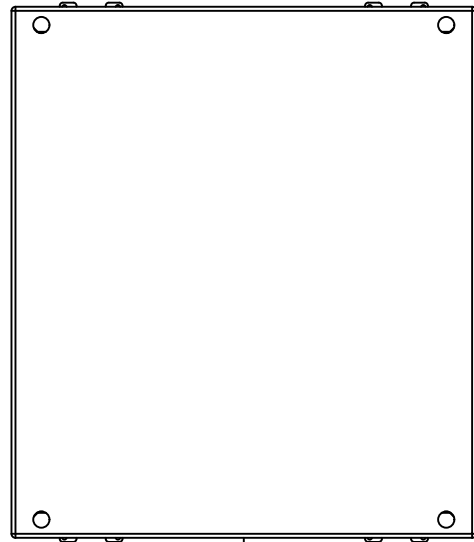

BACK

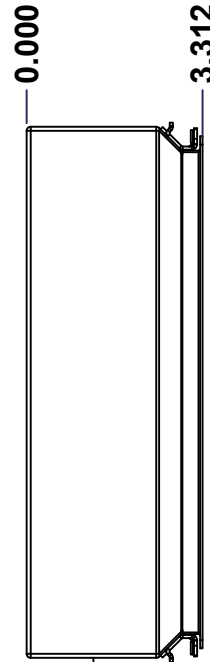

LEFT

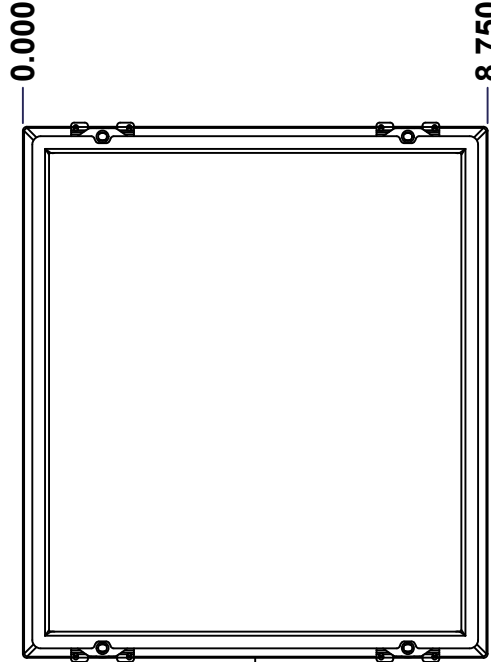

FRONT

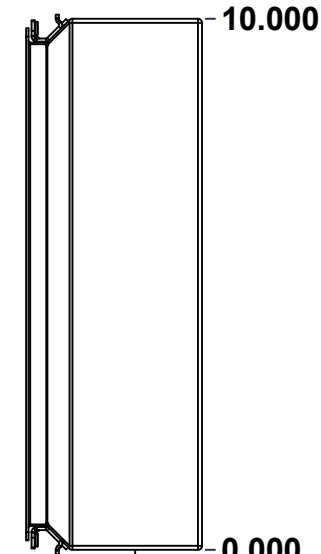

RIGHT

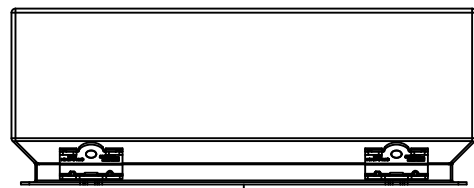

BOTTOM

No.	Revisions	Date	By/Par

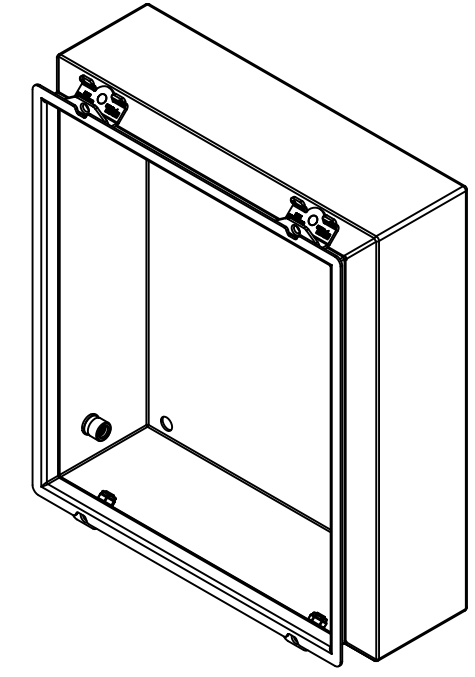

Isometric View



Tél: (450) 979-4373
 Fax: (450) 979-4626
www.exmweb.com

Flatness
Aplatissement
Max 3.0mm
Projection

Customer Client	Date
Drawn By / Dessiné Par: BoxCad: Zin	Date: 29-Sep-20
Material / Matière: 18 Ga H.R.P. & O. (1.2mm)	
Color / Couleur: Asa-61 Grey	Finish / Fini: Smooth
Description: 1412SDC 10" x 8.75" x 3" Body	
Part Number / Numéro Pièce: 1412SDC090803B	Detail Rev. / Rev. 1

SEE BILL OF MATERIAL ON LAST PAGE

Rev. 0 / 7

This drawing is confidential and must not be reproduced or used without the consent of EXM

STANDARD FEATURES ARE NOT LISTED IN THIS HOLE TABLE

Ce dessin est confidentiel et ne doit pas être reproduit ou utilisé sans le consentement de EXM

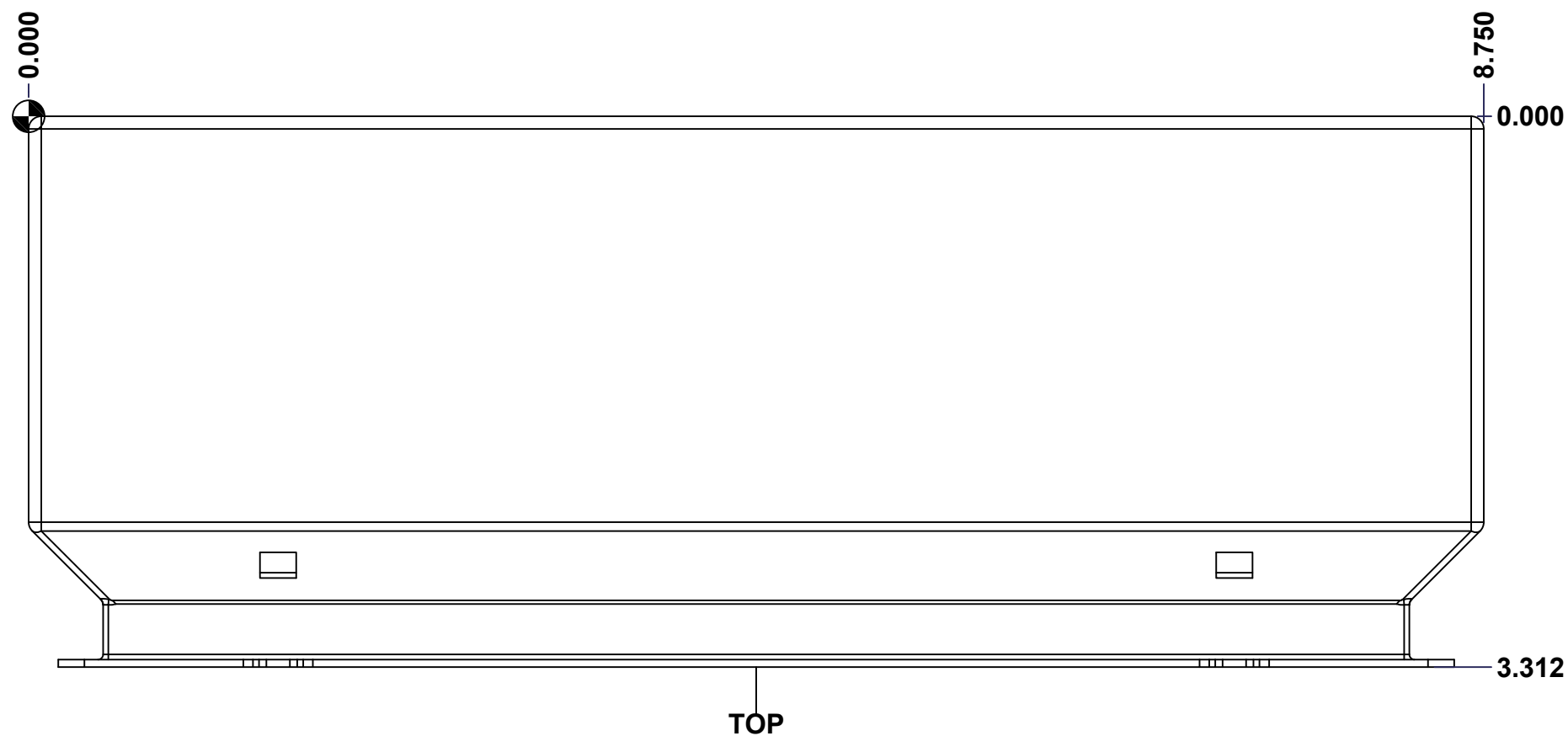

	Description		Status
	1412SDC 10" x 8.75" x 3" Body		(NULL)
Part Number Numéro Pièce		Rev.	2
1412SDC090803B		0	7

This drawing is confidential and must not be reproduced or used without the consent of EXM

STANDARD FEATURES ARE NOT LISTED IN THIS HOLE TABLE

Ce dessin est confidentiel et ne doit pas être reproduit ou utilisé sans le consentement de EXM

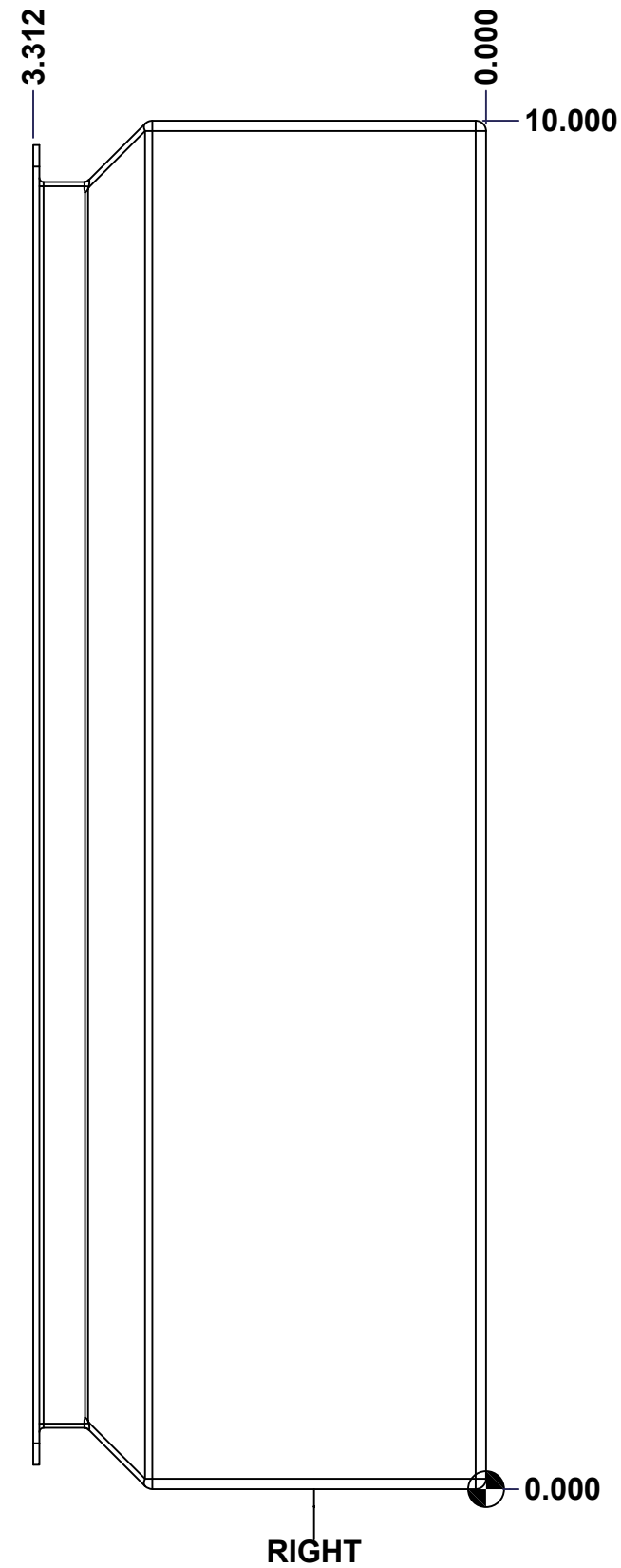

	Description		Status	
	1412SDC 10" x 8.75" x 3" Body		(NULL)	
Part Number Numéro Pièce		Rev.	3	
1412SDC090803B		0	7	

This drawing is confidential and must not be reproduced or used without the consent of EXM

STANDARD FEATURES ARE NOT LISTED IN THIS HOLE TABLE

Ce dessin est confidentiel et ne doit pas être reproduit ou utilisé sans le consentement de EXM

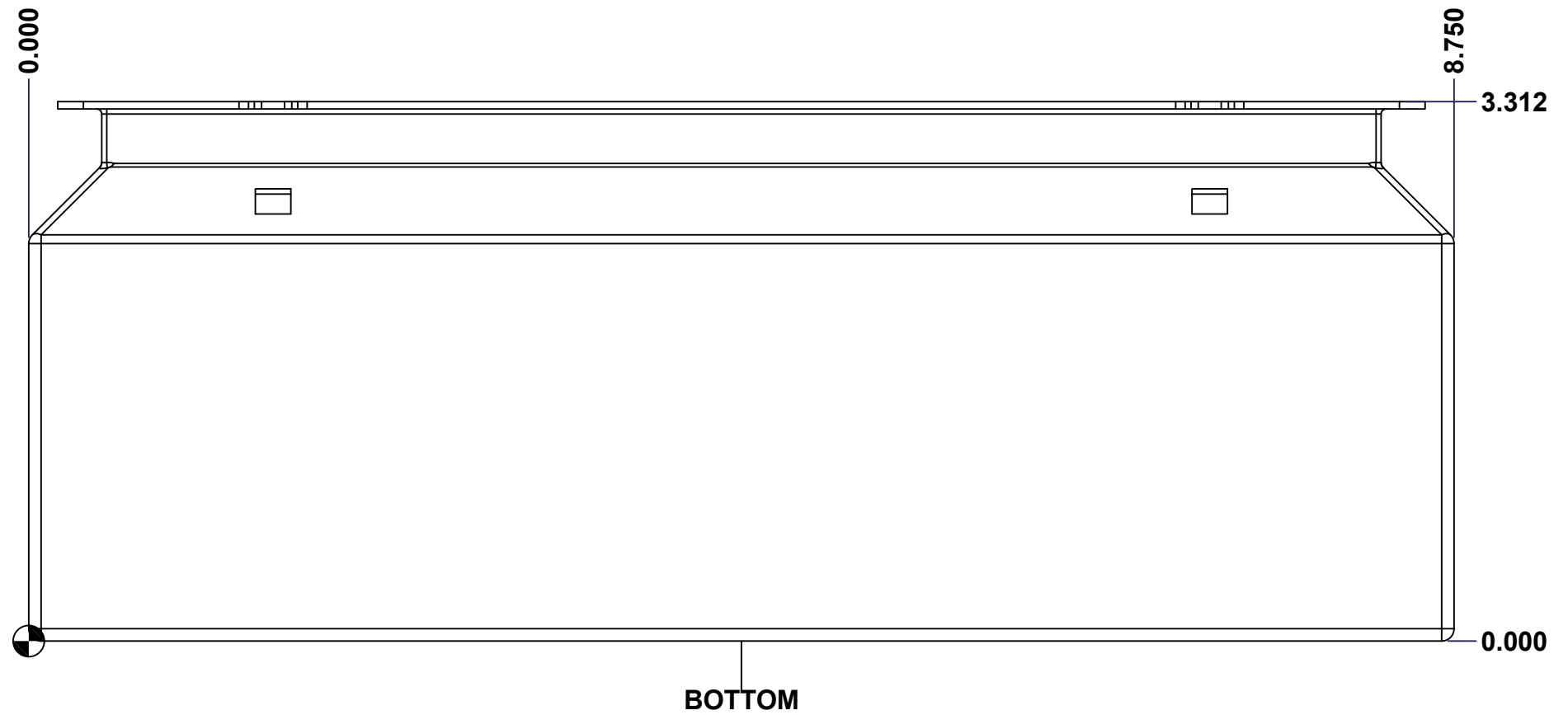

	Description		Status
	1412SDC 10" x 8.75" x 3" Body		(NULL)
Part Number Numéro Pièce		Rev.	
1412SDC090803B		0	4 7

This drawing is confidential and must not be reproduced or used without the consent of EXM

Ce dessin est confidentiel et ne doit pas être reproduit ou utilisé sans le consentement de EXM

STANDARD FEATURES ARE NOT LISTED IN THIS HOLE TABLE			
HOLE TABLE - LEFT VIEW (CUSTOM FEATURE ONLY)			
CUT-OUT	XDIM	YDIM	DESCRIPTION
1	1.625	0.875	STANDOFF M6 x 10mm (Inside)

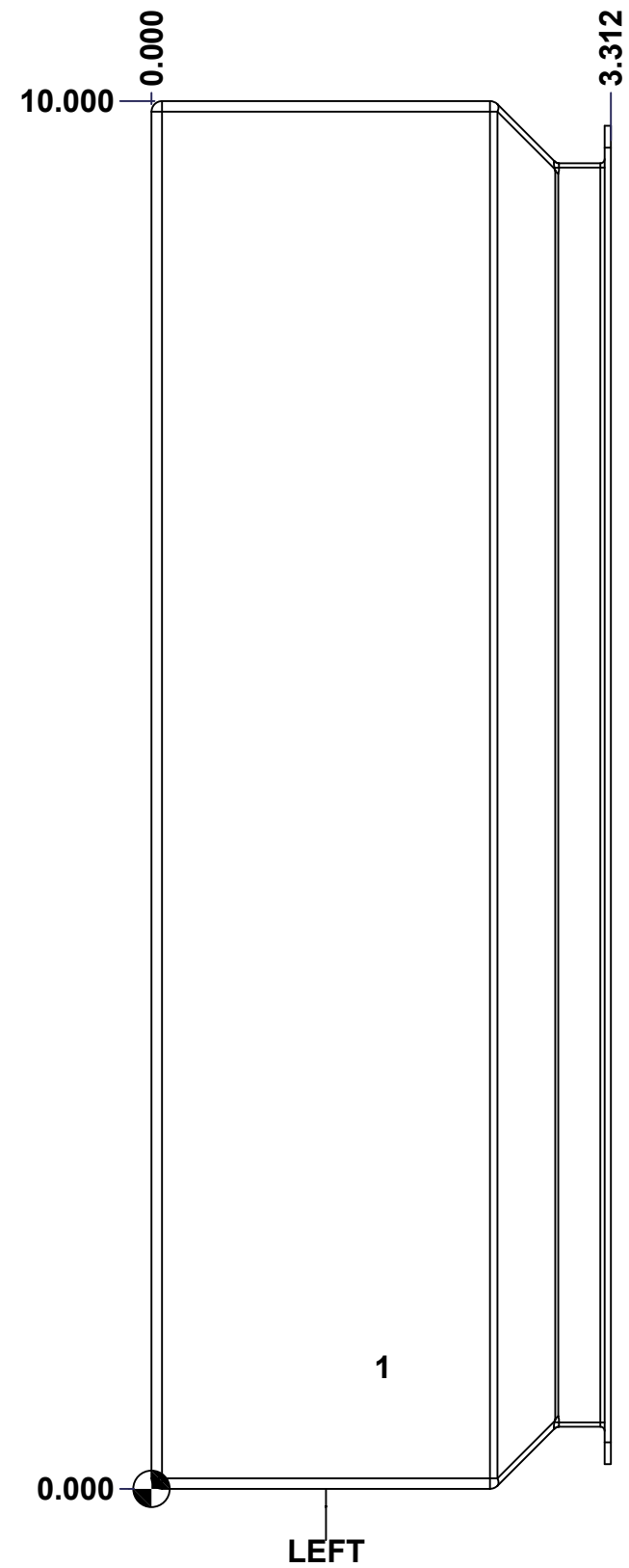

	Description	Status	
	1412SDC 10" x 8.75" x 3" Body	(NULL)	
	Part Number Numéro Pièce	Rev.	5
	1412SDC090803B	0	7

This drawing is confidential and must not be reproduced or used without the consent of EXM

Ce dessin est confidentiel et ne doit pas être reproduit ou utilisé sans le consentement de EXM

STANDARD FEATURES ARE NOT LISTED IN THIS HOLE TABLE

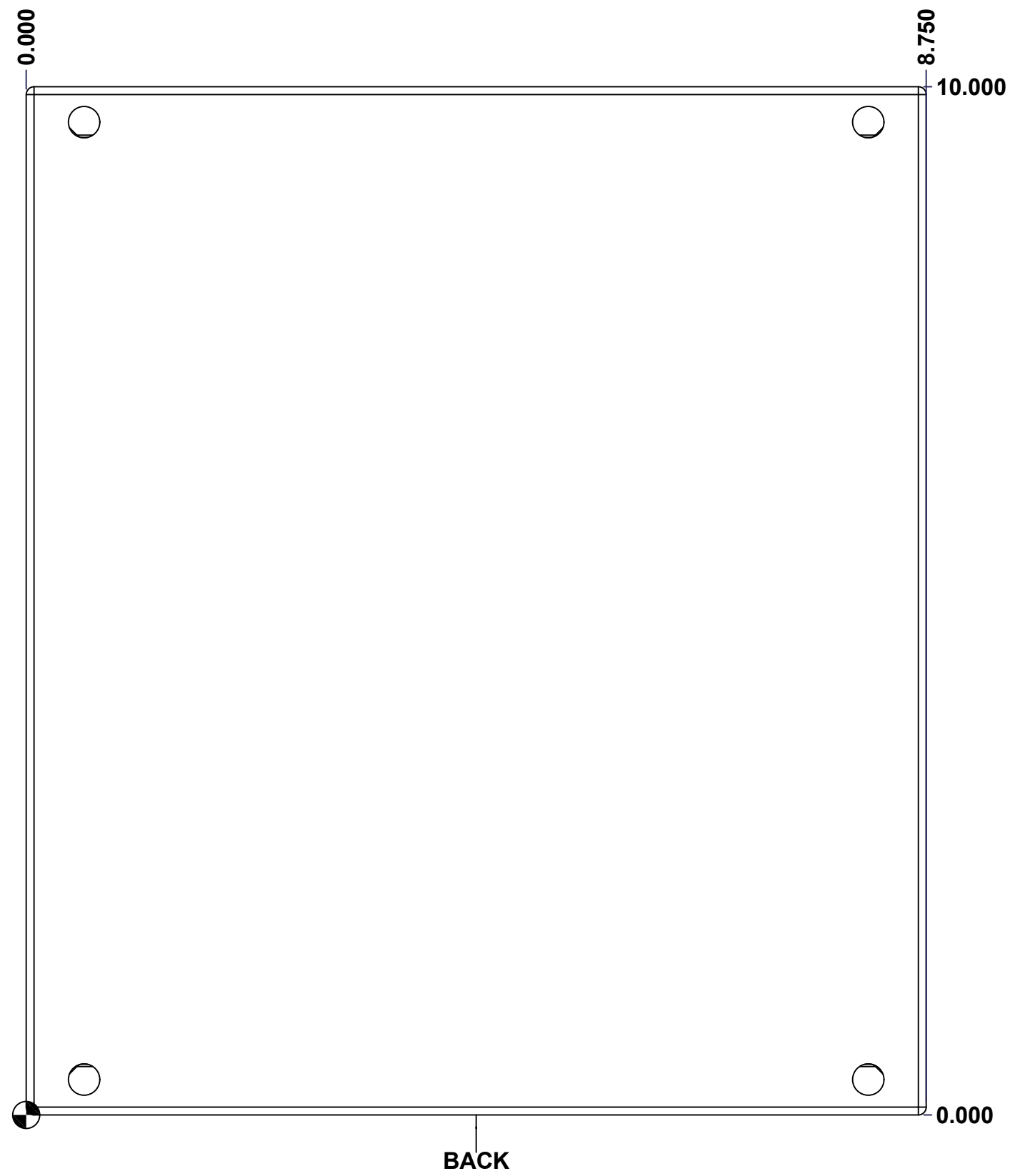

	Description	Status
	1412SDC 10" x 8.75" x 3" Body	(NULL)
	Part Number Numéro Pièce	Rev.
	1412SDC090803B	0
		6
		7

This drawing is confidential and must not be reproduced or used without the consent of EXM

Ce dessin est confidentiel et ne doit pas être reproduit ou utilisé sans le consentement de EXM

No.	Revisions	Date	By/Par

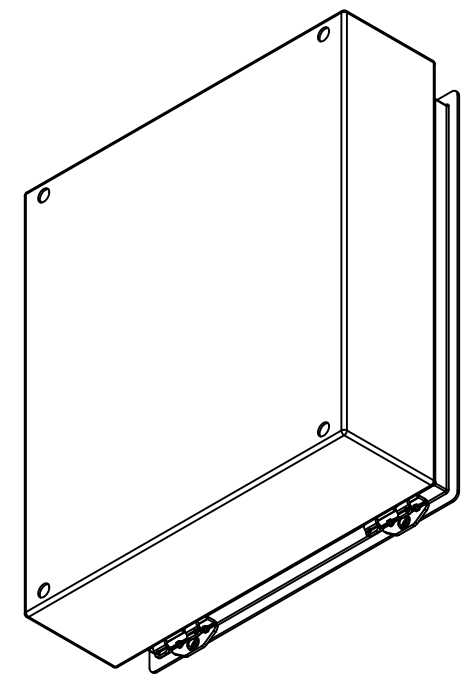

Isometric View

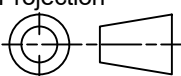

 Tél: (450) 979-4373 Fax: (450) 979-4626 www.exmweb.com	Flatness Aplatissement	Max 3.0mm
	Projection	
Customer Client	Date	
Drawn By Dessiné Par	BoxCad: Zin	Date 29-Sep-20
Material Matière	18 Ga H.R.P. & O. (1.2mm)	
Color Couleur	Asa-61 Grey	Finish Fini Smooth
Description	Detail Rev.	
1412SDC 10" x 8.75" x 3" Body		
Part Number Numéro Pièce	Rev.	7
1412SDC090803B	0	7

Qty	Part Number	Rev	Description
1	STK-Q-08350	5	Standoff M6 x 10mm
1	STK-P-02400S	0	Powder Paint (Asa-61 Grey / Smooth)
1	1412SDC090803B-P	0	1412SDC 10" x 8.75" x 3" Body Part
4	STK-Q-08100	1	M5 Nylon Insert Lock Nut
4	STK-Q-70464	2	5412 ESSC & ESSSC Stainless Steel Body Catch Assembly
Parts List			

This drawing is confidential and must not be reproduced or used without the consent of EXM

Ce dessin est confidentiel et ne doit pas être reproduit ou utilisé sans le consentement de EXM

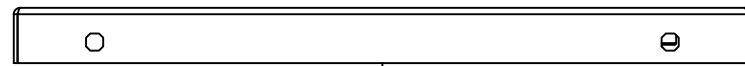

TOP

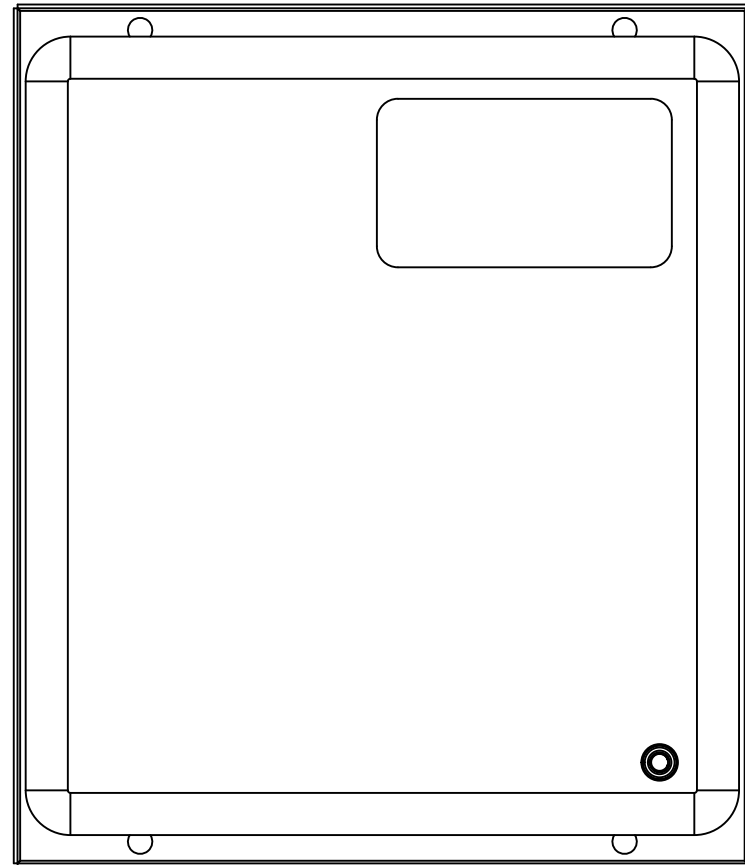

BACK

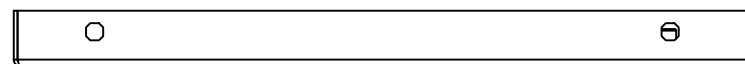

BOTTOM

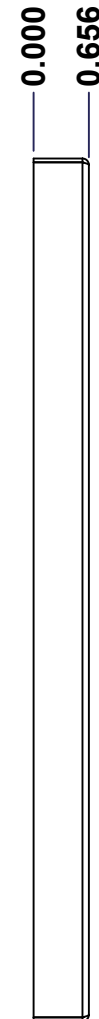

LEFT

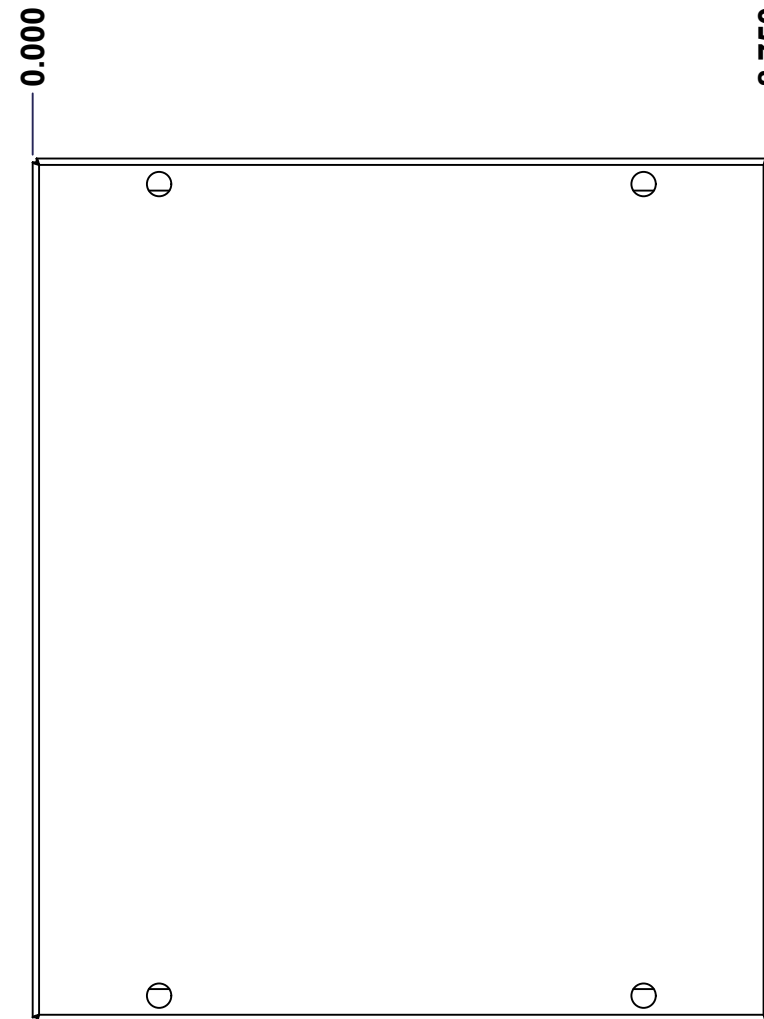

FRONT

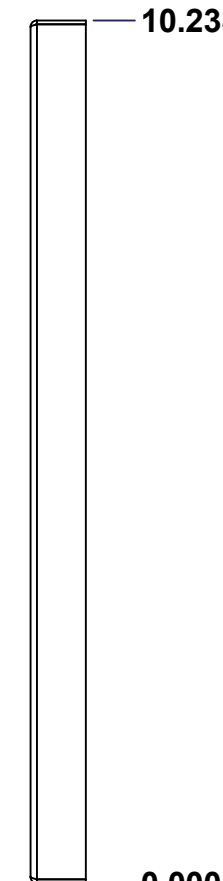

RIGHT

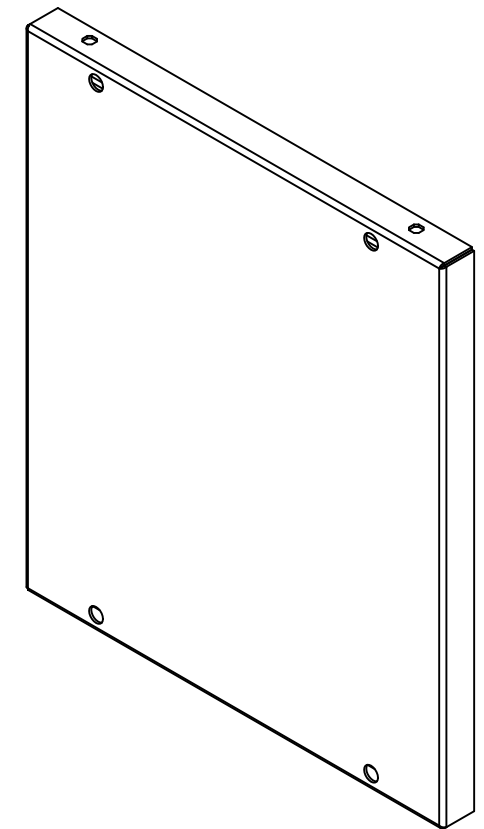

Isometric View

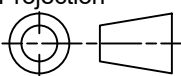

No.	Revisions	Date	By/Par

 Tél: (450) 979-4373 Fax: (450) 979-4626 www.exmweb.com		Flatness Aplatissement Max 3.0mm Projection 
Customer Client	Date	
Drawn By Dessiné Par	BoxCad: Zin	Date 29-Sep-20
Material Matière	18 Ga H.R.P. & O. (1.2mm)	
Color Couleur	Asa-61 Grey	Finish Fini Smooth
Description	Detail Rev.	
1412SDC 10" x 8.75" Cover		
Part Number Numéro Pièce	Rev. 0	1 3
1412SDC090803C		

SEE BILL OF MATERIAL ON LAST PAGE

This drawing is confidential and must not be reproduced or used without the consent of EXM

Ce dessin est confidentiel et ne doit pas être reproduit ou utilisé sans le consentement de EXM

STANDARD FEATURES ARE NOT LISTED IN THIS HOLE TABLE			
HOLE TABLE - FRONT VIEW (CUSTOM FEATURE ONLY)			
CUT-OUT	XDIM	YDIM	DESCRIPTION
1	1.145	1.125	STANDOFF M6 x 10mm (Inside)
2	2.750	8.000	LABEL_EXM

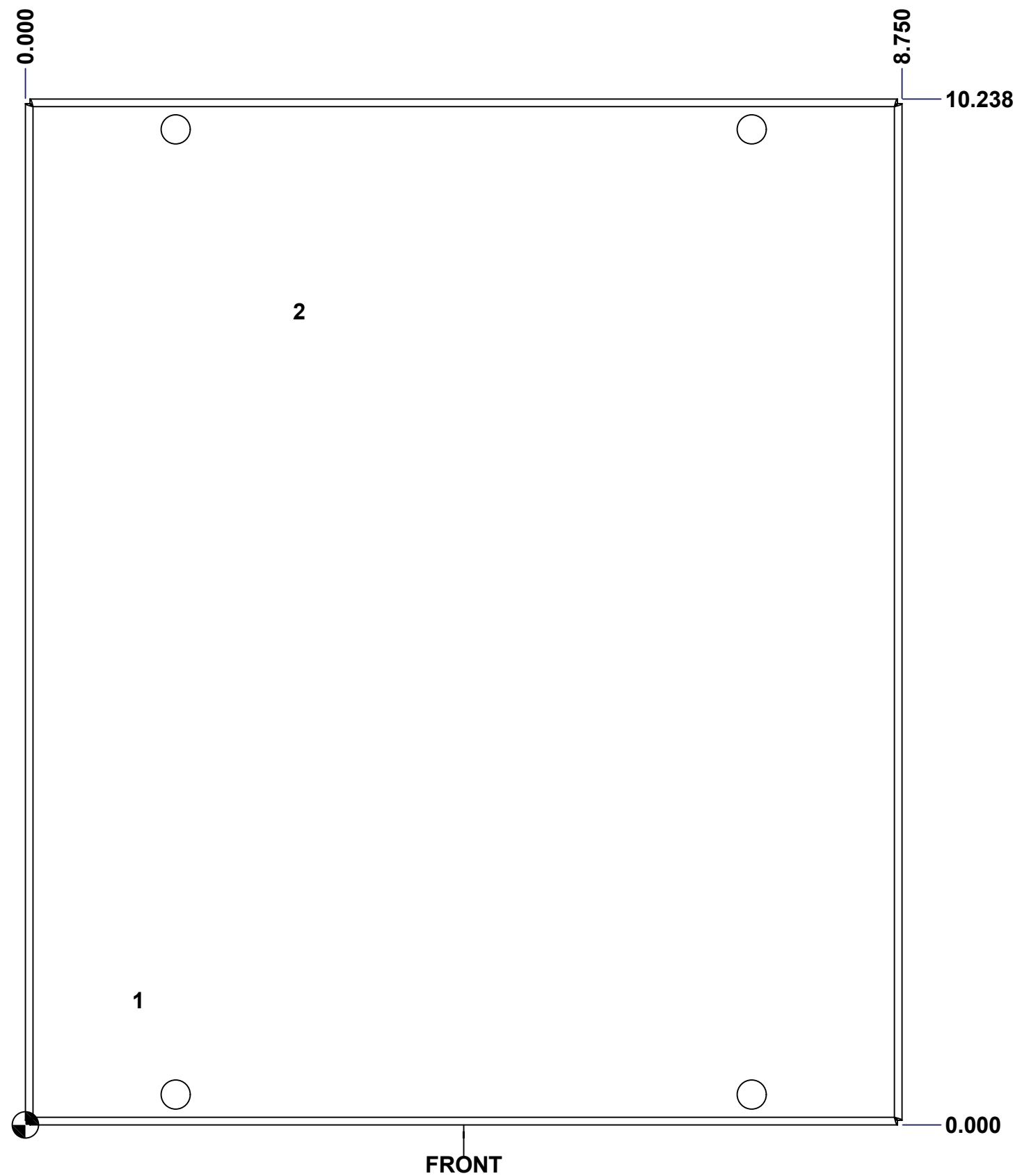

	Description	Status	
	1412SDC 10" x 8.75" Cover	(NULL)	
	Part Number Numéro Pièce	Rev.	
	1412SDC090803C	0	2 / 3

This drawing is confidential and must not be reproduced or used without the consent of EXM

Ce dessin est confidentiel et ne doit pas être reproduit ou utilisé sans le consentement de EXM

No.	Revisions	Date	By/Par

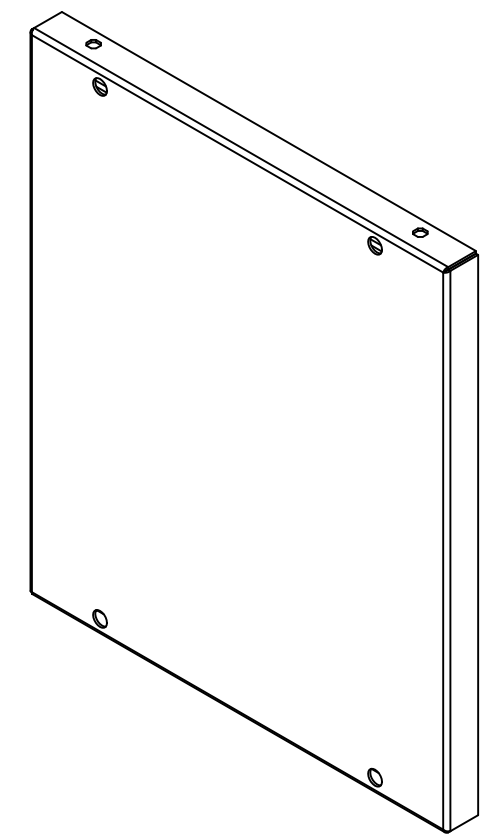

Isometric View

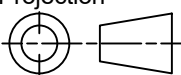

 Tél: (450) 979-4373 Fax: (450) 979-4626 www.exmweb.com		Flatness Aplatissement Max 3.0mm Projection 
Customer Client	Date	
Drawn By Dessiné Par	BoxCad: Zin	Date 29-Sep-20
Material Matière	18 Ga H.R.P. & O. (1.2mm)	
Color Couleur	Asa-61 Grey	Finish Fini Smooth
Description		Detail Rev.
1412SDC 10" x 8.75" Cover		
Part Number Numéro Pièce	Rev.	3
1412SDC090803C	0	3

Qty	Part Number	Rev	Description
1	STK-Q-08350	5	Standoff M6 x 10mm
1	STK-P-02400S	0	Powder Paint (Asa-61 Grey / Smooth)
1	STK-S-00100	0	3.5" x 2" Silver Milar Flexcon Sticker
1	1412SDC090803G	0	5412ESSC 10" x 8.75" Gasket
1	1412SDC090803C-P	0	1412SDC 10" x 8.75" Cover Part
Parts List			