

This drawing is confidential and must not be reproduced or used without the consent of EXM

Ce dessin est confidentiel et ne doit pas être reproduit ou utilisé sans le consentement de EXM

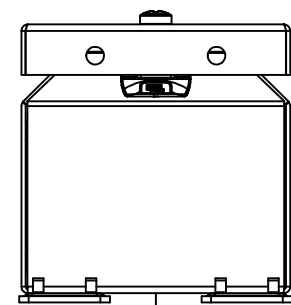

TOP

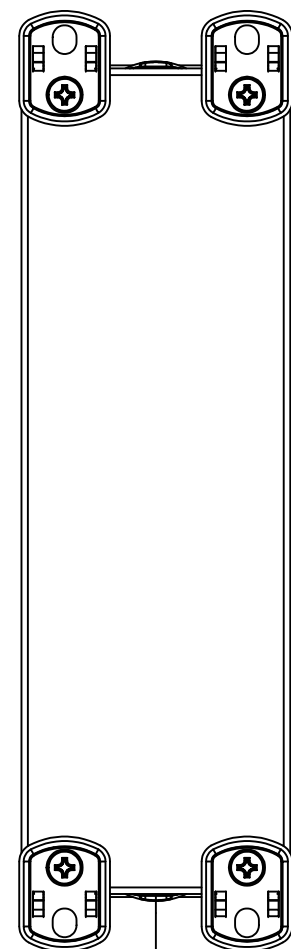

BACK

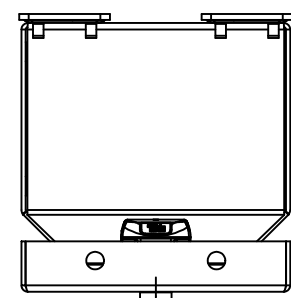

BOTTOM

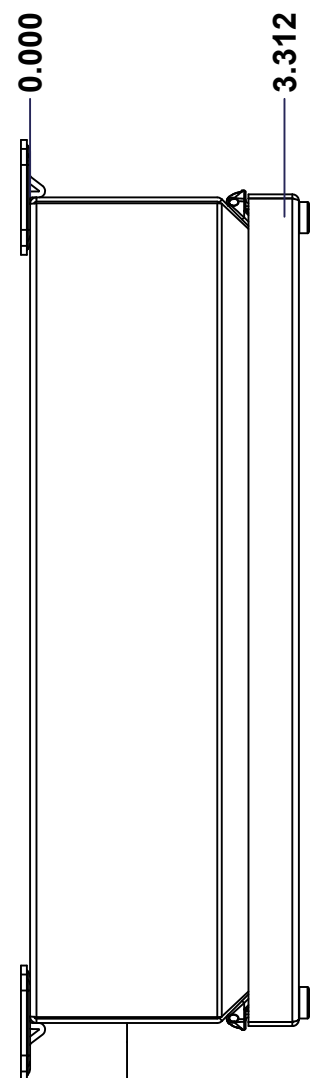

LEFT

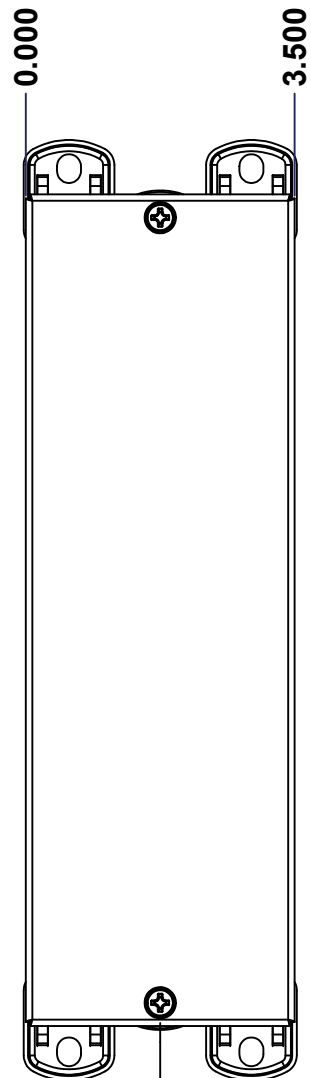

FRONT

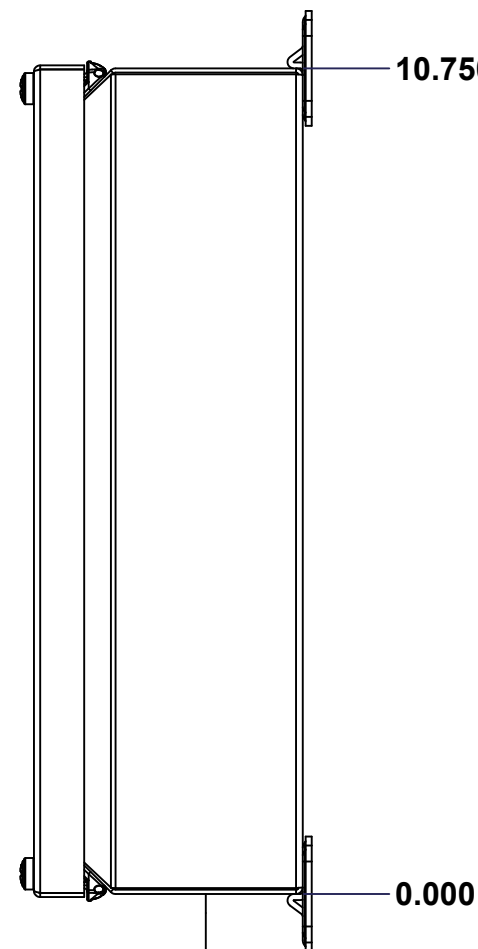

RIGHT

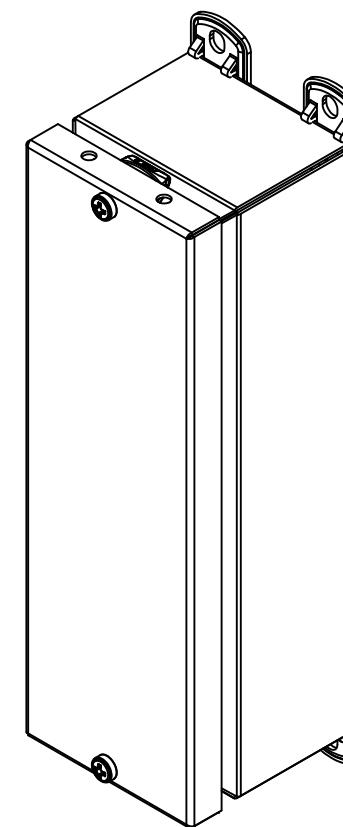

Isometric View

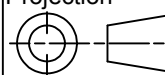

| No. | Revisions | Date | By/Par |
|-----|-----------|------|--------|
|     |           |      |        |
|     |           |      |        |
|     |           |      |        |
|     |           |      |        |

|  |                                     |   |
|--|-------------------------------------|---|
|  Tél: (450) 979-4373<br>Fax: (450) 979-4626<br><a href="http://www.exmweb.com">www.exmweb.com</a> |                                     | Flatness<br>Aplatissement<br>Max 3.0mm<br>Projection<br> |
| Customer<br>Client   | Date                                |   |
| Drawn By<br>Dessiné Par  | BoxCad: patsan                      | Date 06/06/2013   |
| Material<br>Matière  | 16 Ga H.R.P. & O. (1.4mm)           |   |
| Color<br>Couleur   | Asa-61 Grey                         | Finish<br>Fini Smooth   |
| Description  | 1500SDC 10.75" x 3.5" x 3" Assembly |   |
| Part Number<br>Numéro Pièce  | 1500SDC100302                       | Detail Rev.   |
|  | Rev. 0                              | 1/2   |

SEE BILL OF MATERIAL ON LAST PAGE

This drawing is confidential and must not be reproduced or used without the consent of EXM

Ce dessin est confidentiel et ne doit pas être reproduit ou utilisé sans le consentement de EXM

| No. | Revisions | Date | By/Par |
|-----|-----------|------|--------|
|     |           |      |        |
|     |           |      |        |
|     |           |      |        |
|     |           |      |        |
|     |           |      |        |

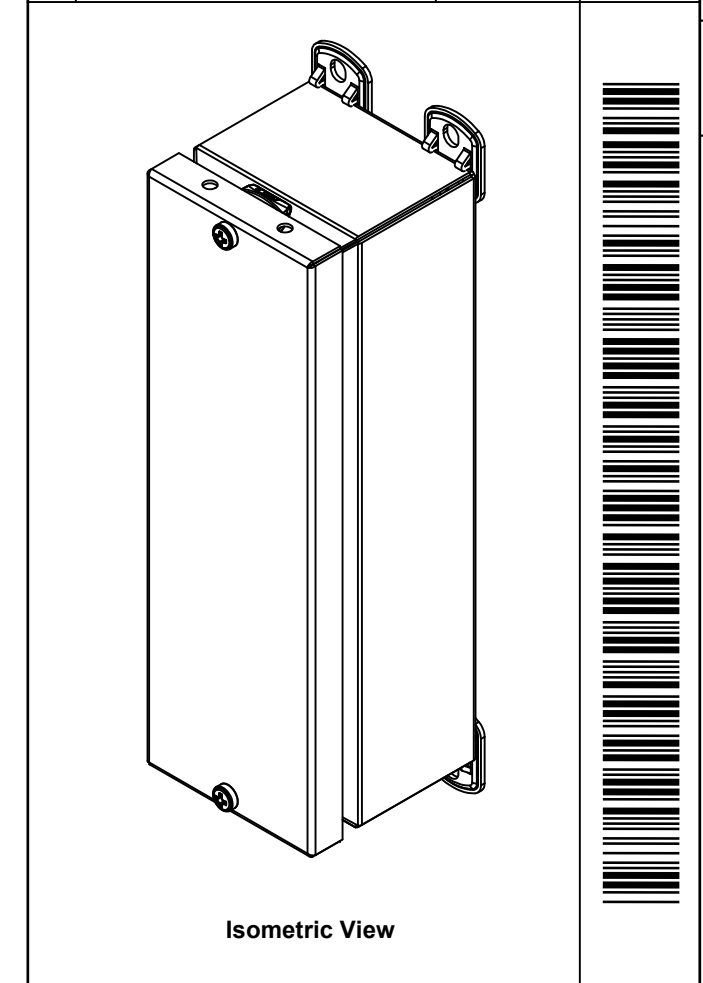

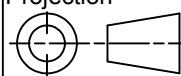
|  |                           |   |
|--|---------------------------|---|
|  Tél: (450) 979-4373<br>Fax: (450) 979-4626<br><a href="http://www.exmweb.com">www.exmweb.com</a> |                           | Flatness<br>Aplatissement<br>Max 3.0mm<br>Projection<br> |
| Customer<br>Client   | Date                      |   |
| Drawn By<br>Dessiné Par  | BoxCad: patsan            | Date 06/06/2013   |
| Material<br>Matière  | 16 Ga H.R.P. & O. (1.4mm) |   |
| Color<br>Couleur   | Asa-61 Grey               | Finish<br>Fini Smooth   |
| Description  |                           | Detail Rev.   |
| 1500SDC 10.75" x 3.5" x 3" Assembly  |                           |   |
| Part Number<br>Numéro Pièce  | <b>1500SDC100302</b>      | Rev. 2<br><b>0</b>  |

| Qty        | Part Number    | Rev | Description                                      |
|------------|----------------|-----|--|
| 1          | 1500SDC100302C | 0   | 1500SDC 10.75" x 3.5" Cover                      |
| 1          | STK-K-09500-02 | 0   | Pushbutton Accessory Kit (2 Screws Construction) |
| 1          | 1500SDC100302B | 0   | 1500SDC 10.75" x 3.5" x 3" Body                  |
| Parts List |                |     |  |

This drawing is confidential and must not be reproduced or used without the consent of EXM

Ce dessin est confidentiel et ne doit pas être reproduit ou utilisé sans le consentement de EXM

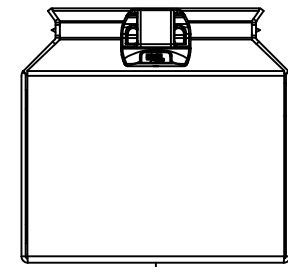

TOP

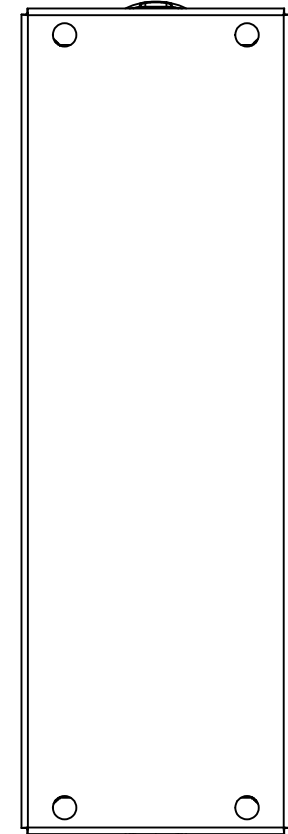

BACK

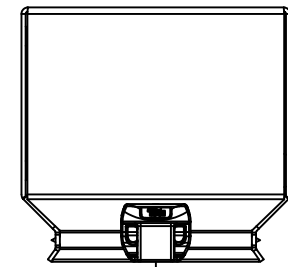

BOTTOM

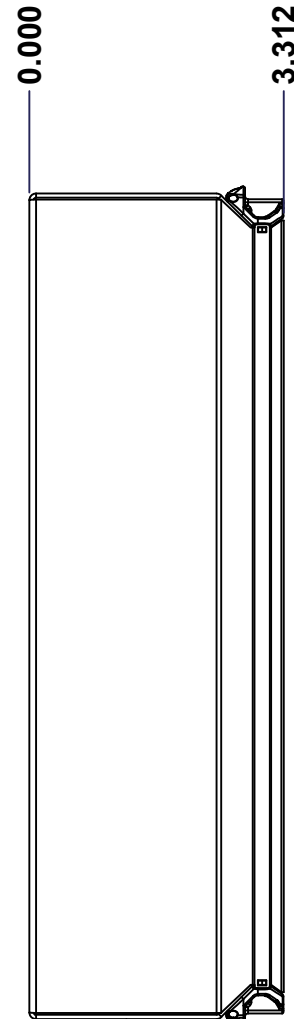

LEFT

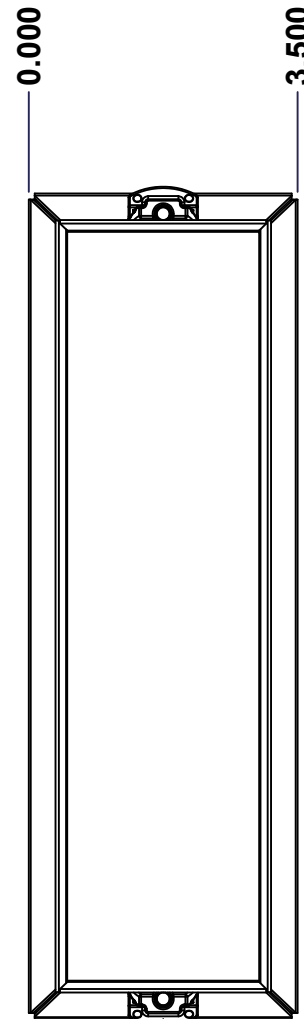

FRONT

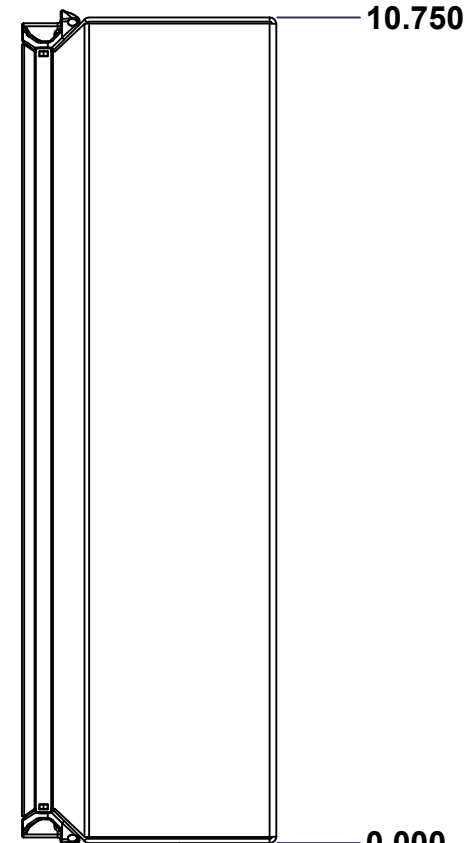

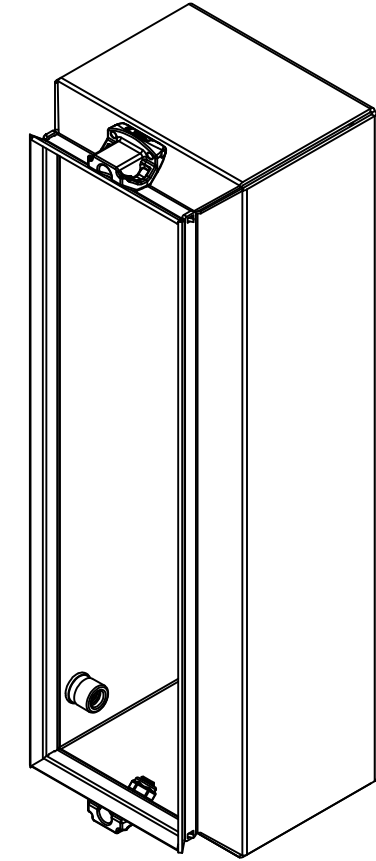

RIGHT

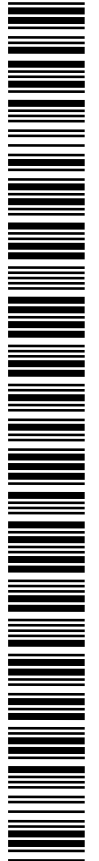

Isometric View

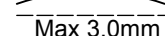

| No. | Revisions | Date | By/Par |
|-----|-----------|------|--------|
|     |           |      |        |
|     |           |      |        |
|     |           |      |        |
|     |           |      |        |

|  |                           |  |
|--|---------------------------|--|
|  Tél: (450) 979-4373<br>Fax: (450) 979-4626<br><a href="http://www.exmweb.com">www.exmweb.com</a> |                           | Flatness<br>Aplatissement<br><br>Max 3.0mm<br>Projection<br> |
| Customer Client  | Date                      |  |
| Drawn By<br>Dessiné Par  | BoxCad: patsan            | Date 06/06/2013  |
| Material<br>Matière  | 16 Ga H.R.P. & O. (1.4mm) |  |
| Color<br>Couleur   | Asa-61 Grey               | Finish<br>Fini Smooth  |
| Description  | Detail Rev.               |  |
| 1500SDC 10.75" x 3.5" x 3" Body  |                           |  |
| Part Number<br>Numéro Pièce  | Rev.                      | 1<br>7   |
| 1500SDC100302B   | 0                         |  |

SEE BILL OF MATERIAL ON LAST PAGE

This drawing is confidential and must not be reproduced or used without the consent of EXM

Ce dessin est confidentiel et ne doit pas être reproduit ou utilisé sans le consentement de EXM

| No. | Revisions | Date | By/Par |
|-----|-----------|------|--------|
|     |           |      |        |
|     |           |      |        |
|     |           |      |        |
|     |           |      |        |
|     |           |      |        |

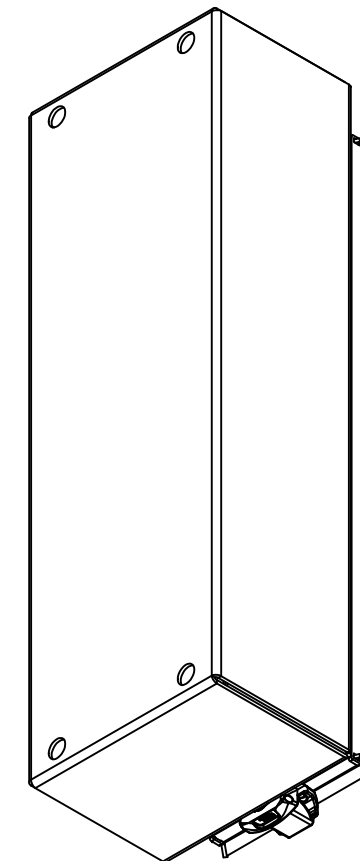

Isometric View

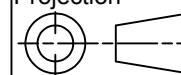

|  |   |
|--|---|
|  Tél: (450) 979-4373<br>Fax: (450) 979-4626<br><a href="http://www.exmweb.com">www.exmweb.com</a> | Flatness<br>Aplatissement   |
|  | Max 3.0mm   |
| Projection   |  |
| Customer<br>Client   | Date  |
| Drawn By<br>Dessiné Par  | Date  |
| Material<br>Matière  | 16 Ga H.R.P. & O. (1.4mm)   |
| Color<br>Couleur   | Asa-61 Grey   |
| Finish<br>Fini   | Smooth  |
| Description  | Detail Rev.   |
| Part Number<br>Numéro Pièce  | Rev.  |
| <b>1500SDC100302B</b>  | <b>0</b>  |

| Qty        | Part Number      | Rev   | Description                                     |
|------------|------------------|-------|---|
| 1          | STK-P-02400S     | 0     | Powder Paint (Asa-61 Grey / Smooth)             |
| 1          | STK-S-00100      | 0.1.1 | 3.5" x 2" Silver Milar Flexcon Sticker          |
| 1          | 1500SDC100302B-P | 0     | 1500SDC 10.75" x 3.5" x 3" Body Part            |
| 1          | STK-Q-08350      | 4     | Standoff M6 x 10mm                              |
| 2          | STK-Q-08100      | 1     | M5 Nylon Insert Lock Nut                        |
| 2          | STK-Q-70463      | 0     | 5412ESMSC - Zinc Casting Body Catch Screw Cover |
| Parts List |                  |       |   |

7  
7

This drawing is confidential and must not be reproduced or used without the consent of EXM

Ce dessin est confidentiel et ne doit pas être reproduit ou utilisé sans le consentement de EXM

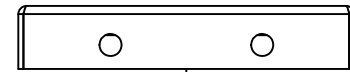

TOP

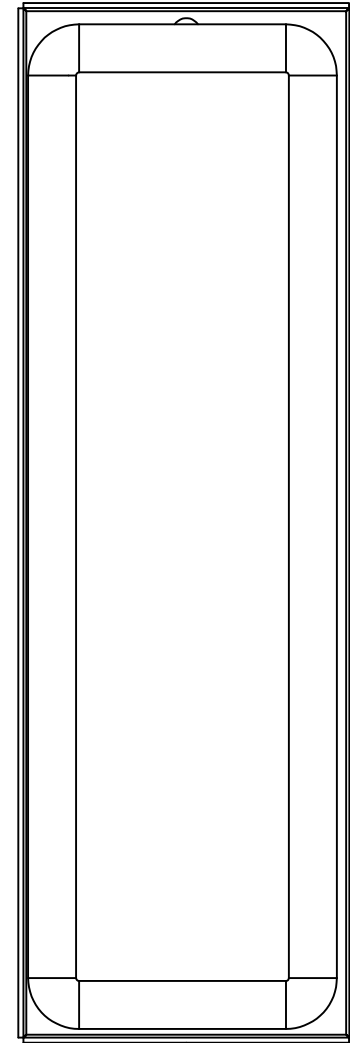

BACK

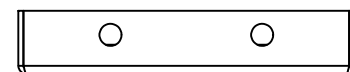

BOTTOM



LEFT

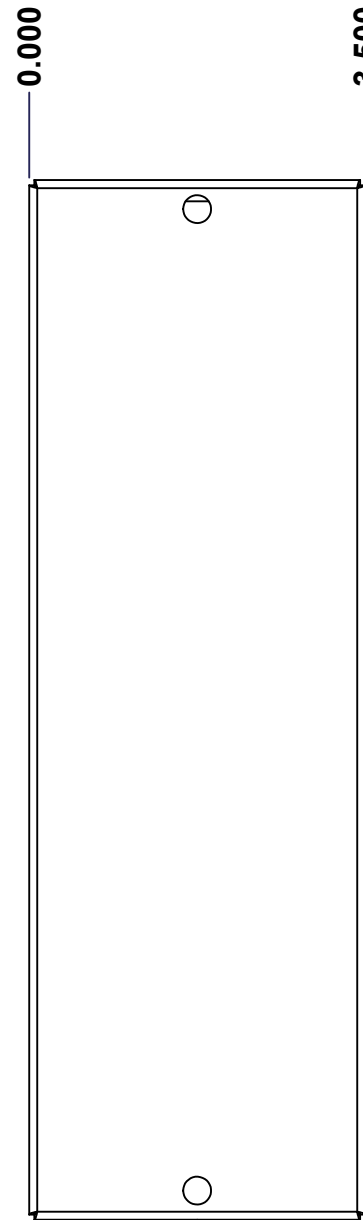

FRONT

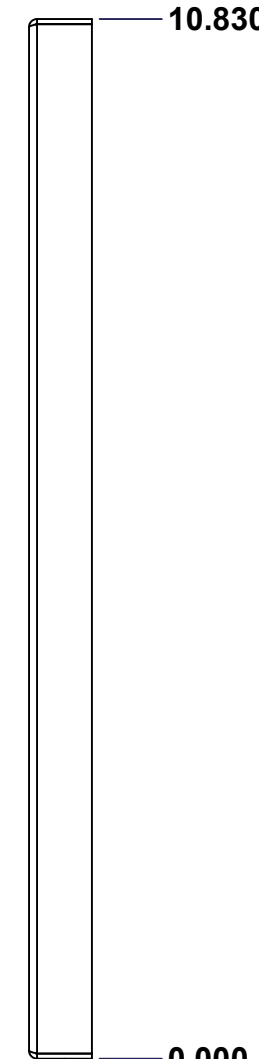

RIGHT

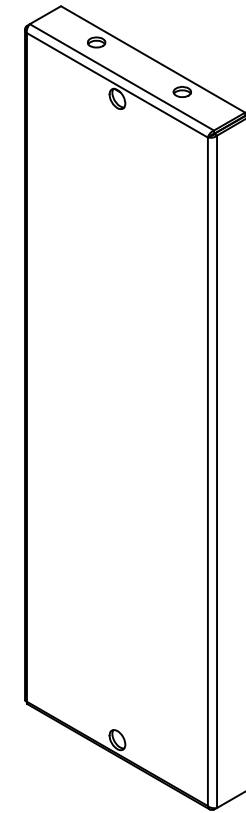

Isometric View

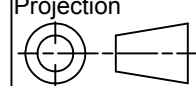

| No. | Revisions | Date | By/Par |
|-----|-----------|------|--------|
|     |           |      |        |
|     |           |      |        |
|     |           |      |        |
|     |           |      |        |

|  |                           |   |
|--|---------------------------|---|
|  Tél: (450) 979-4373<br>Fax: (450) 979-4626<br><a href="http://www.exmweb.com">www.exmweb.com</a> |                           | Flatness<br>Aplatissement<br>Max 3.0mm<br>Projection<br> |
| Customer Client  | Date                      |   |
| Drawn By<br>Dessiné Par  | BoxCad: patsan            | Date 06/06/2013   |
| Material<br>Matière  | 16 Ga H.R.P. & O. (1.4mm) |   |
| Color<br>Couleur   | Asa-61 Grey               | Finish<br>Fini Smooth   |
| Description  | Detail Rev.               |   |
| 1500SDC 10.75" x 3.5" Cover  |                           |   |
| Part Number<br>Numéro Pièce  | Rev.                      | 1   |
| 1500SDC100302C   | 0                         | 3   |

SEE BILL OF MATERIAL ON LAST PAGE

This drawing is confidential and must not be reproduced or used without the consent of EXM

Ce dessin est confidentiel et ne doit pas être reproduit ou utilisé sans le consentement de EXM

| No. | Revisions | Date | By/Par |
|-----|-----------|------|--------|
|     |           |      |        |
|     |           |      |        |
|     |           |      |        |
|     |           |      |        |
|     |           |      |        |

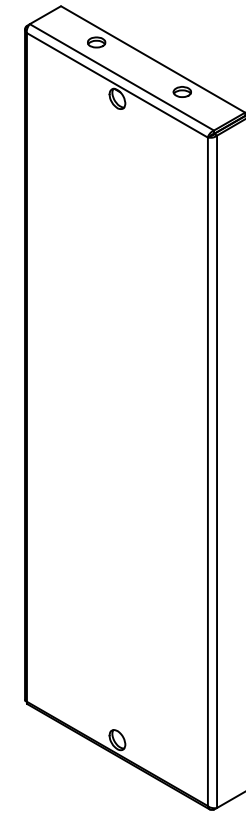

Isometric View

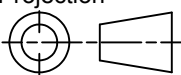

|  |                           |   |
|--|---------------------------|---|
|  Tél: (450) 979-4373<br>Fax: (450) 979-4626<br><a href="http://www.exmweb.com">www.exmweb.com</a> |                           | Flatness<br>Aplatissement<br>Max 3.0mm<br>Projection<br> |
| Customer Client  | Date                      |   |
| Drawn By<br>Dessiné Par  | BoxCad: patsan            | Date 06/06/2013   |
| Material<br>Matière  | 16 Ga H.R.P. & O. (1.4mm) |   |
| Color<br>Couleur   | Asa-61 Grey               | Finish<br>Fini Smooth   |
| Description  | Detail Rev.               |   |
| 1500SDC 10.75" x 3.5" Cover  |                           |   |
| Part Number<br>Numéro Pièce  | Rev.                      | 3   |
| <b>1500SDC100302C</b>  | <b>0</b>                  | <b>3</b>  |

| Qty        | Part Number      | Rev | Description                         |
|------------|------------------|-----|-------------------------------------|
| 1          | STK-P-02400S     | 0   | Powder Paint (Asa-61 Grey / Smooth) |
| 1          | 1500SDC100302G   | 0   | 1500SDC 10.75" x 3.5" Gasket        |
| 1          | 1500SDC100302C-P | 0   | 1500SDC 10.75" x 3.5" Cover Part    |
| Parts List |                  |     |                                     |