

This drawing is confidential and must not be reproduced or used without the consent of EXM

Ce dessin est confidentiel et ne doit pas être reproduit ou utilisé sans le consentement de EXM

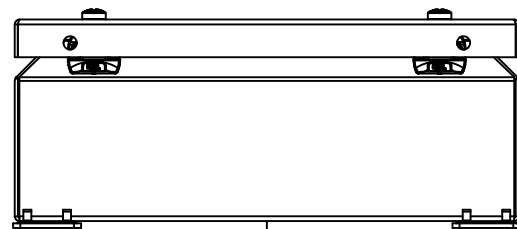

TOP

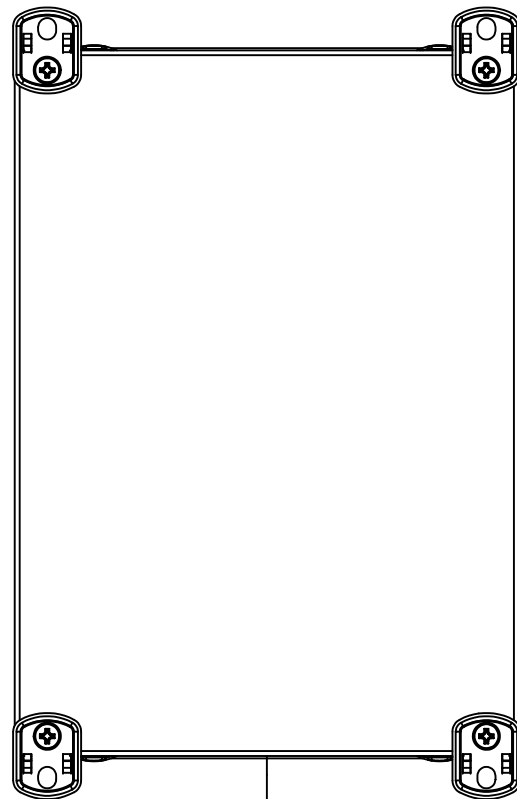

BACK

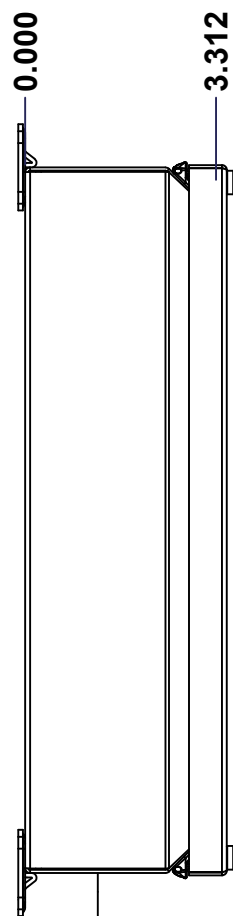

LEFT

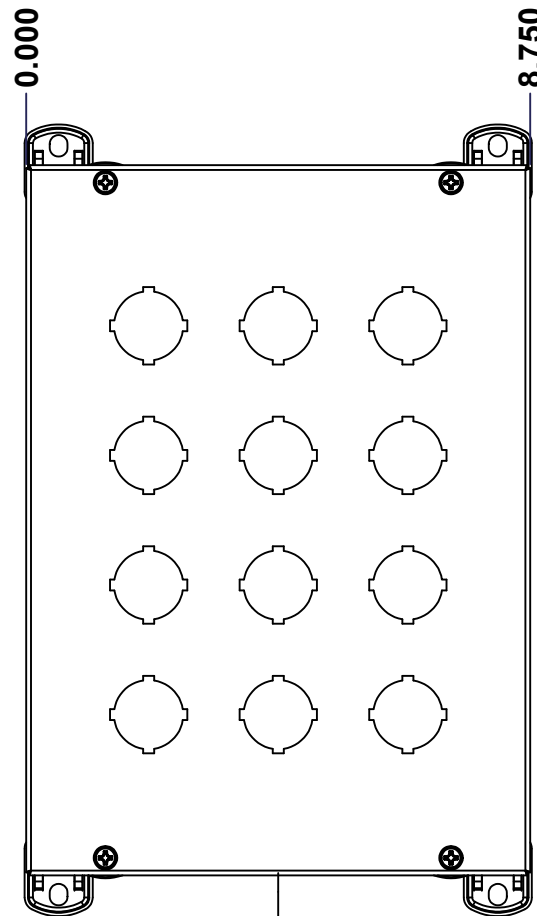

FRONT

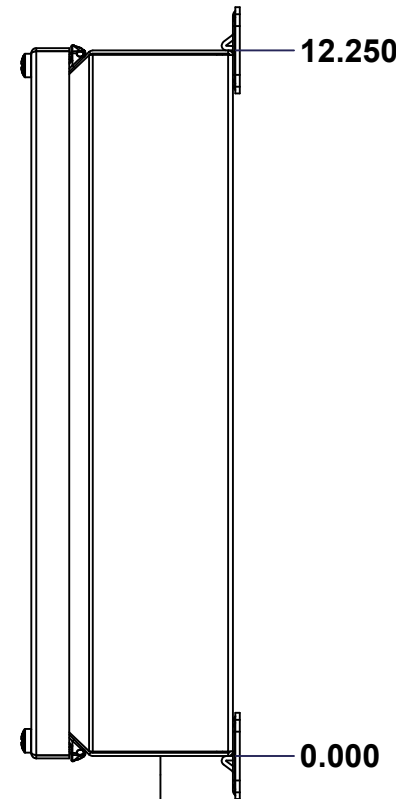

RIGHT

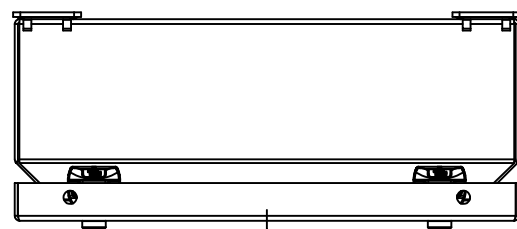

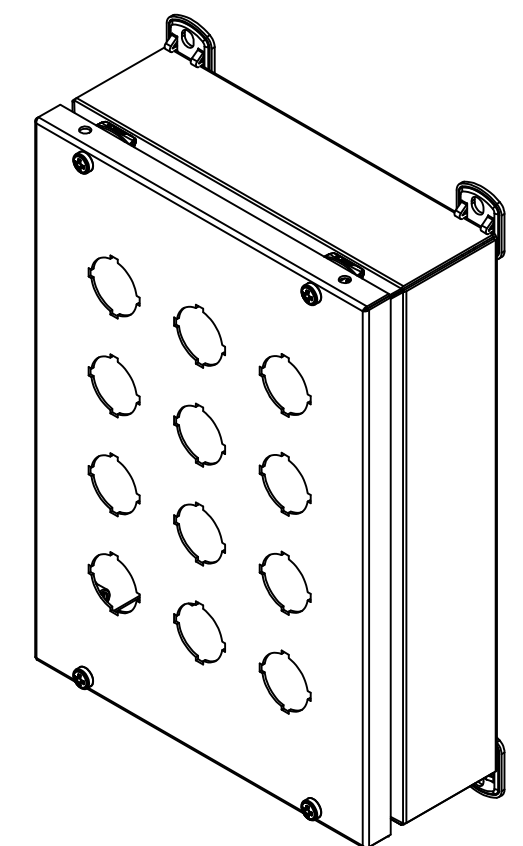

BOTTOM

No.	Revisions	Date	By/Par

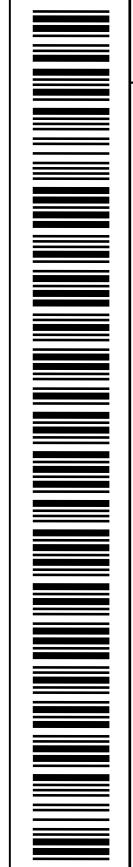

Isometric View

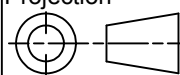

 Tél: (450) 979-4373 Fax: (450) 979-4626 www.exmweb.com		Flatness Aplatissement Max 3.0mm Projection 
Customer Client	Date	
Drawn By Dessiné Par BoxCad: patsan	Date 06/06/2013	
Material Matière 16 Ga Stainless Steel 304 (1.4mm)		
Color Couleur Outside Unpainted and Inside White RAL9003	Finish Fini Brushed	
Description 1412SDSS 12.25" x 8.75" x 3" Assembly		Detail Rev.
Part Number Numéro Pièce 1412SDSS110803	Rev. 0	1 2

SEE BILL OF MATERIAL ON LAST PAGE

This drawing is confidential and must not be reproduced or used without the consent of EXM

Ce dessin est confidentiel et ne doit pas être reproduit ou utilisé sans le consentement de EXM

No.	Revisions	Date	By/Par

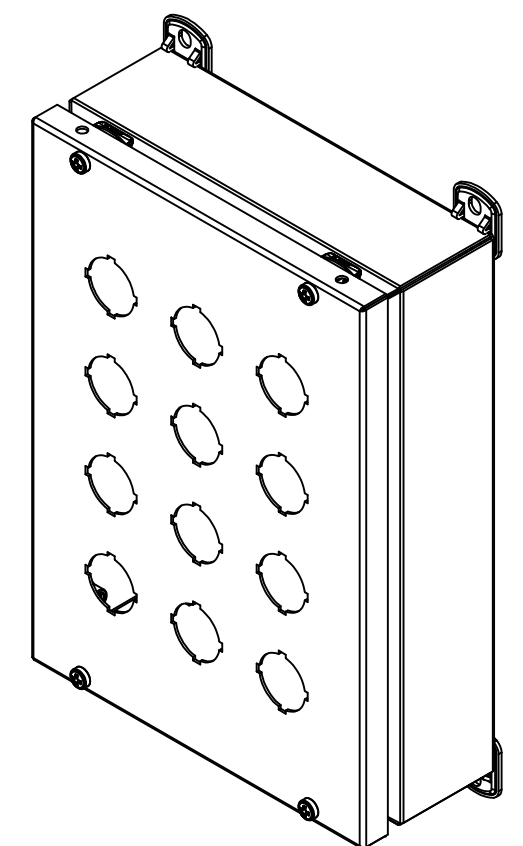

Isometric View

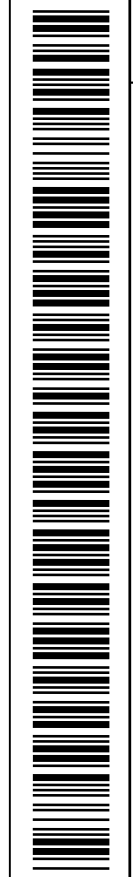

Tél: (450) 979-4373
 Fax: (450) 979-4626
www.exmweb.com

Flatness
Aplatissement
Max 3.0mm
Projection

Customer Client	Date
Drawn By Dessiné Par BoxCad: patsan	Date 06/06/2013
Material Matière 16 Ga Stainless Steel 304 (1.4mm)	

Color Couleur Outside Unpainted and Inside White RAL9003	Finish Fini Brushed
---	------------------------

Qty	Part Number	Rev	Description
1	1412SDSS110803C	0	1412SDSS 12.25" x 8.75" Cover
1	STK-K-09600-04	0	Pushbutton Accessory Kit (4 Screws Construction)
1	1412SDSS110803B	0	1412SDSS 12.25" x 8.75" x 3" Body
Parts List			

Description 1412SDSS 12.25" x 8.75" x 3" Assembly	Detail Rev.
Part Number Numéro Pièce 1412SDSS110803	Rev. 2 0

This drawing is confidential and must not be reproduced or used without the consent of EXM

Ce dessin est confidentiel et ne doit pas être reproduit ou utilisé sans le consentement de EXM

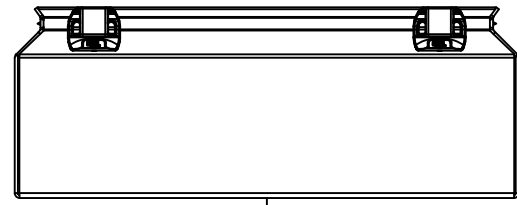

TOP

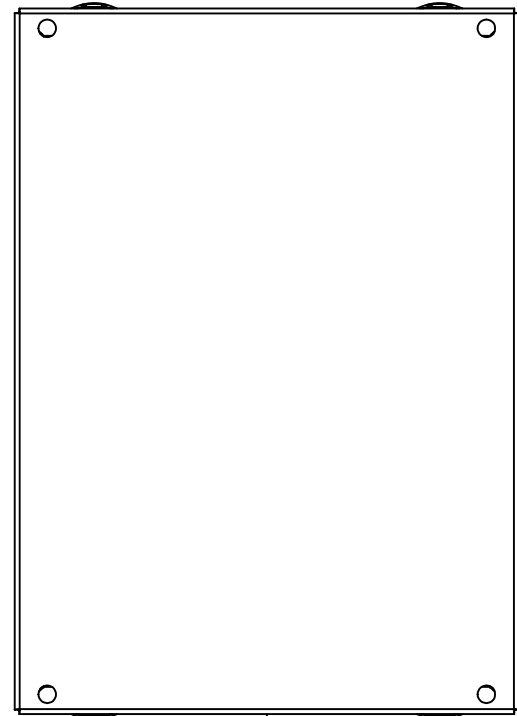

BACK

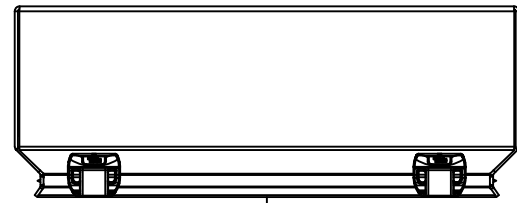

BOTTOM

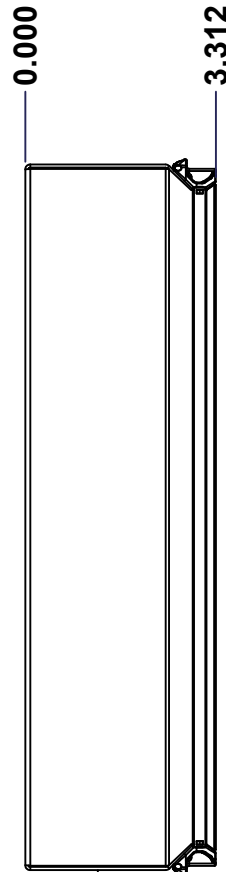

LEFT

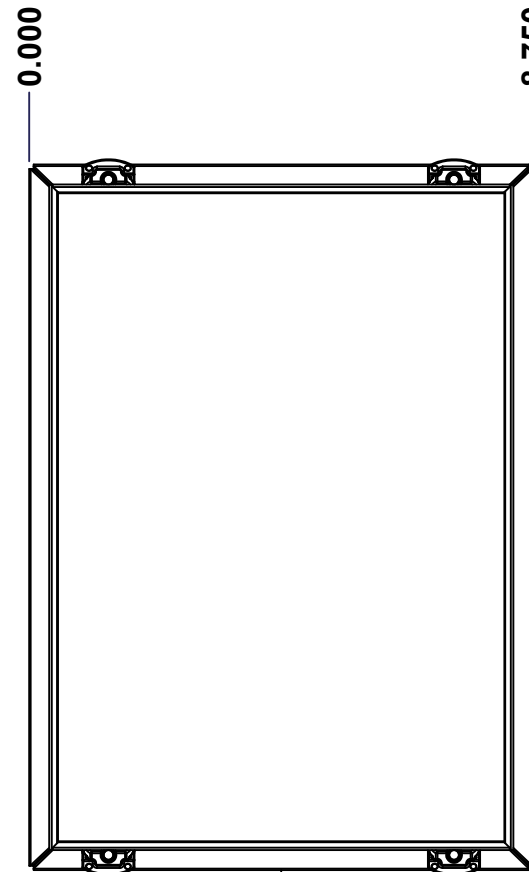

FRONT

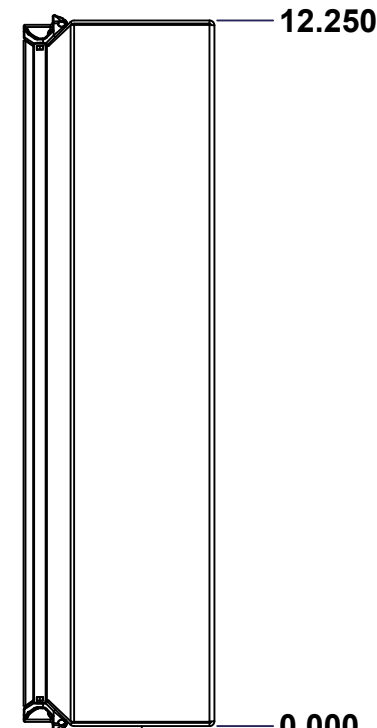

RIGHT

No.	Revisions	Date	By/Par

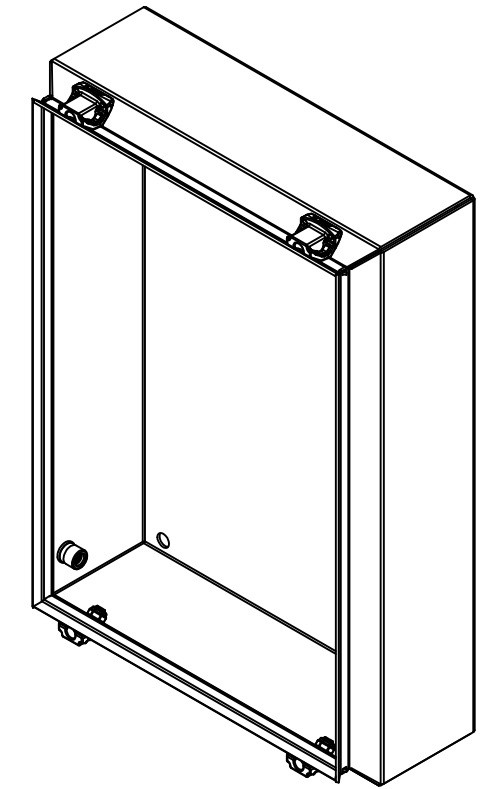

Isometric View

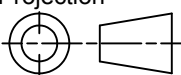

 Tél: (450) 979-4373 Fax: (450) 979-4626 www.exmweb.com		Flatness Aplatissement Max 3.0mm Projection 
Customer Client	Date	
Drawn By Dessiné Par	BoxCad: patsan	Date 06/06/2013
Material Matière	16 Ga Stainless Steel 304 (1.4mm)	
Color Couleur	Outside Unpainted and Inside White RAL9003	Finish Fini Brushed
Description	Detail Rev.	
1412SDSS 12.25" x 8.75" x 3" Body		
Part Number Numéro Pièce	Rev.	1 7
1412SDSS110803B	0	

SEE BILL OF MATERIAL ON LAST PAGE

This drawing is confidential and must not be reproduced or used without the consent of EXM

Ce dessin est confidentiel et ne doit pas être reproduit ou utilisé sans le consentement de EXM

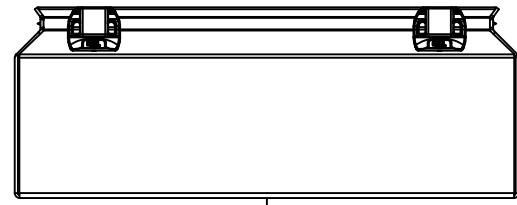

TOP

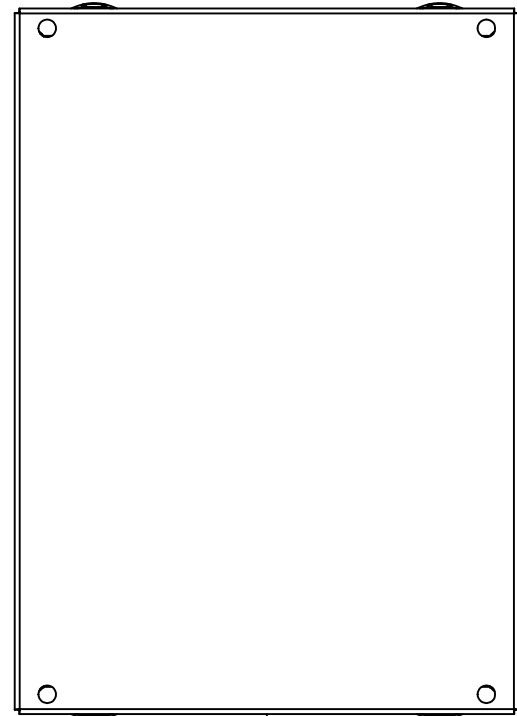

BACK

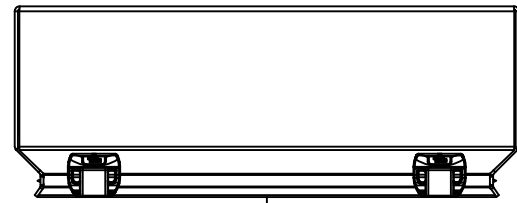

BOTTOM

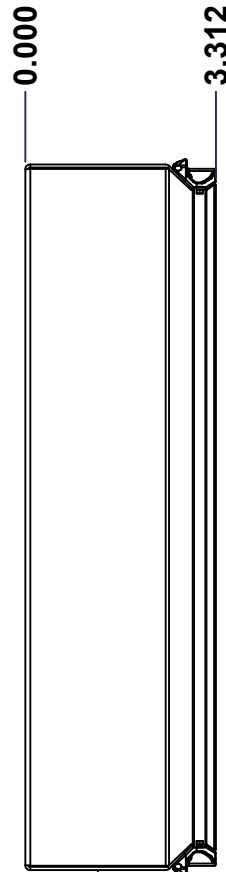

LEFT

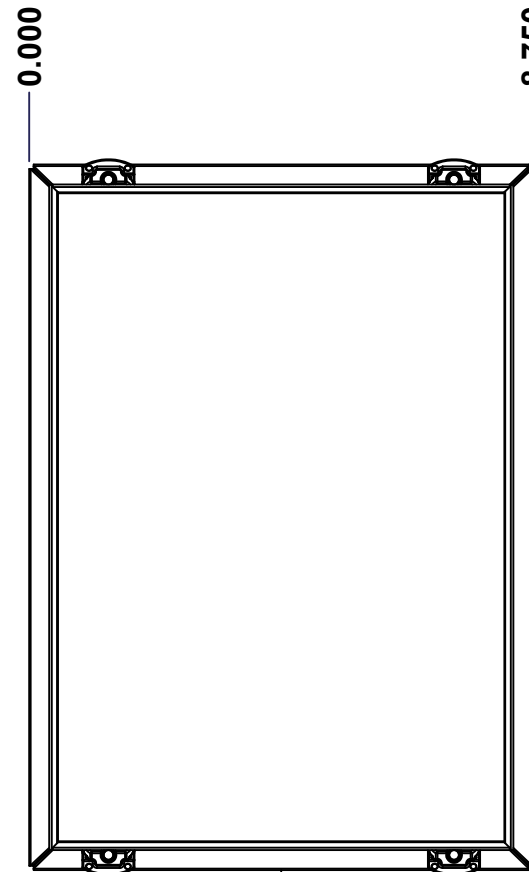

FRONT

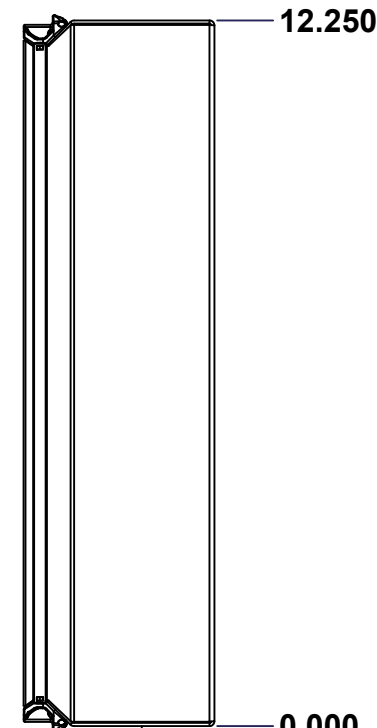

RIGHT

No.	Revisions	Date	By/Par

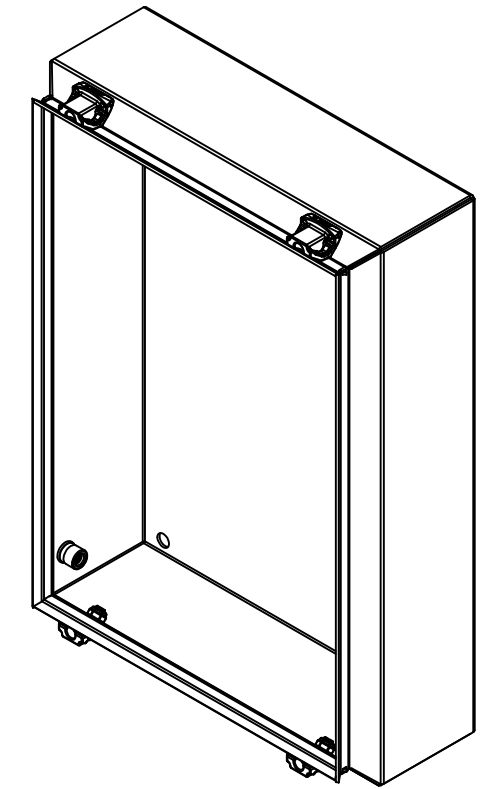

Isometric View



Tél: (450) 979-4373
 Fax: (450) 979-4626
www.exmweb.com

Flatness
Aplatissement

Max 3.0mm

Projection

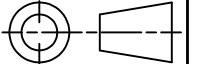

Customer Client	Date
Drawn By / Dessiné Par: BoxCad: patsan	Date: 06/06/2013
Material / Matière: 16 Ga Stainless Steel 304 (1.4mm)	

Color / Couleur: Outside Unpainted and Inside White RAL9003	Finish / Fini: Brushed
---	------------------------

Description: 1412SDSS 12.25" x 8.75" x 3" Body	Detail Rev.
--	-------------

Part Number / Numéro Pièce: 1412SDSS110803B	Rev. 0	1 / 7
---	--------	-------

SEE BILL OF MATERIAL ON LAST PAGE

This drawing is confidential and must not be reproduced or used without the consent of EXM

Ce dessin est confidentiel et ne doit pas être reproduit ou utilisé sans le consentement de EXM

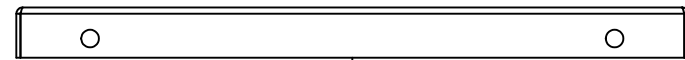

TOP

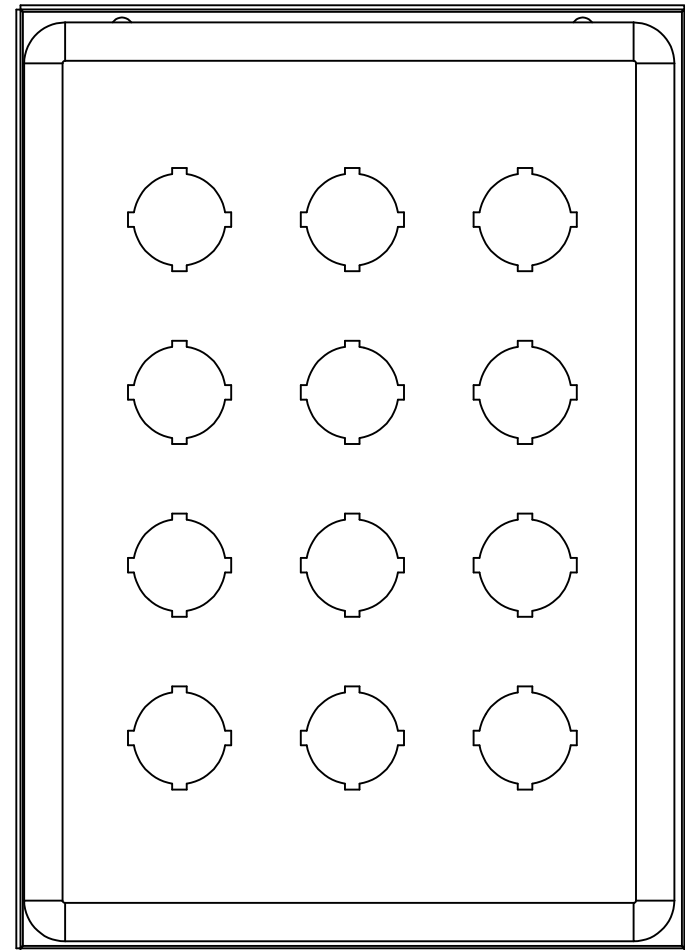

BACK

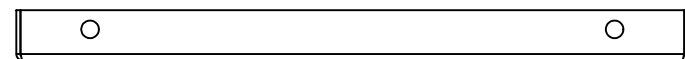

BOTTOM

0.000
0.656

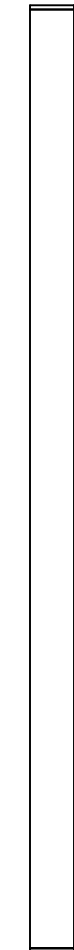

LEFT

0.000
8.750

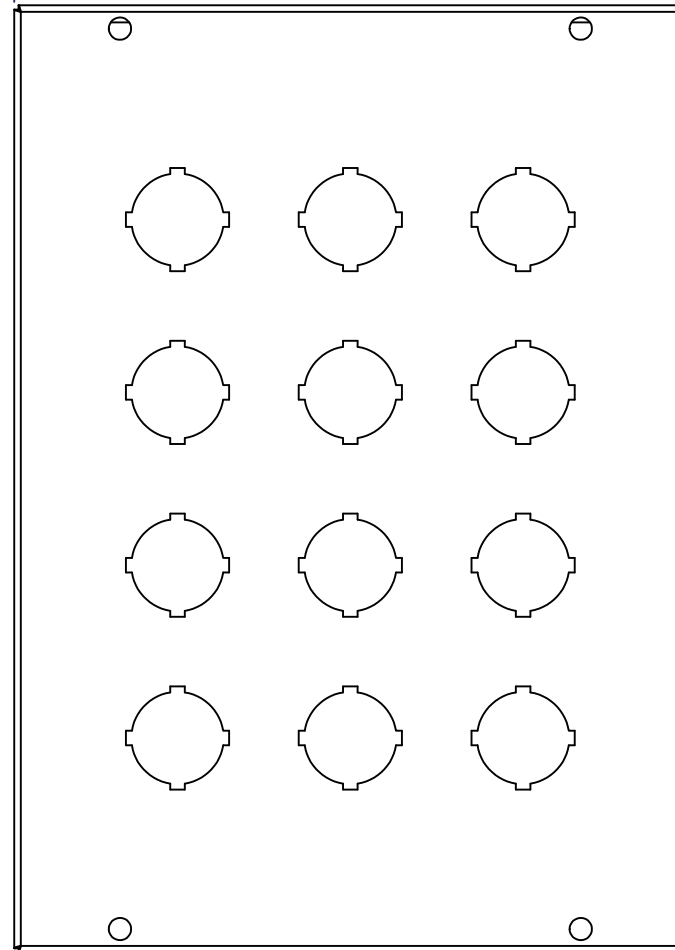

FRONT

12.330

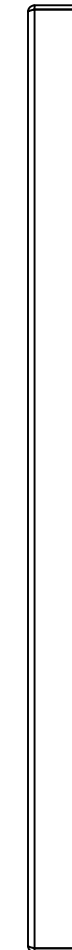

RIGHT

0.000

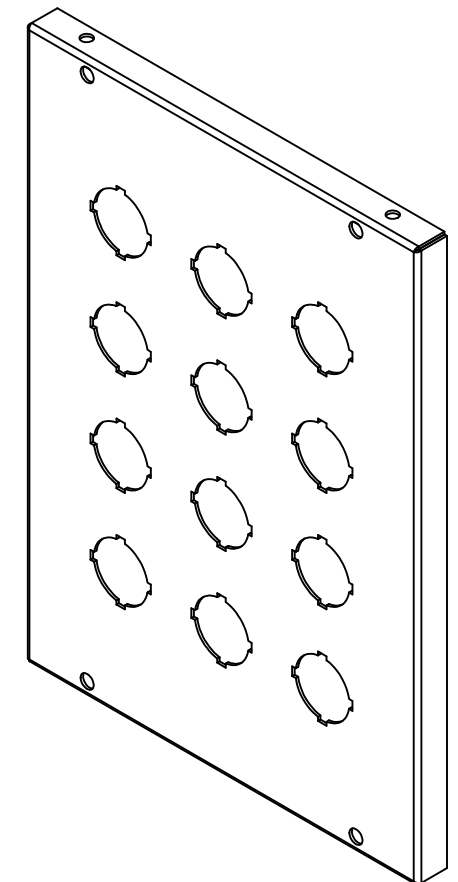

Isometric View

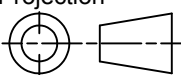

No.	Revisions	Date	By/Par

 Tél: (450) 979-4373 Fax: (450) 979-4626 www.exmweb.com		Flatness Aplatissement Max 3.0mm Projection 
Customer Client	Date	
Drawn By Dessiné Par	BoxCad: patsan	Date 06/06/2013
Material Matière	16 Ga Stainless Steel 304 (1.4mm)	
Color Couleur	Outside Unpainted and Inside White RAL9003	Finish Fini Brushed
Description	Detail Rev.	
1412SDSS 12.25" x 8.75" Cover		
Part Number Numéro Pièce	Rev.	1 3
1412SDSS110803C	0	

SEE BILL OF MATERIAL ON LAST PAGE

This drawing is confidential and must not be reproduced or used without the consent of EXM

Ce dessin est confidentiel et ne doit pas être reproduit ou utilisé sans le consentement de EXM

No.	Revisions	Date	By/Par

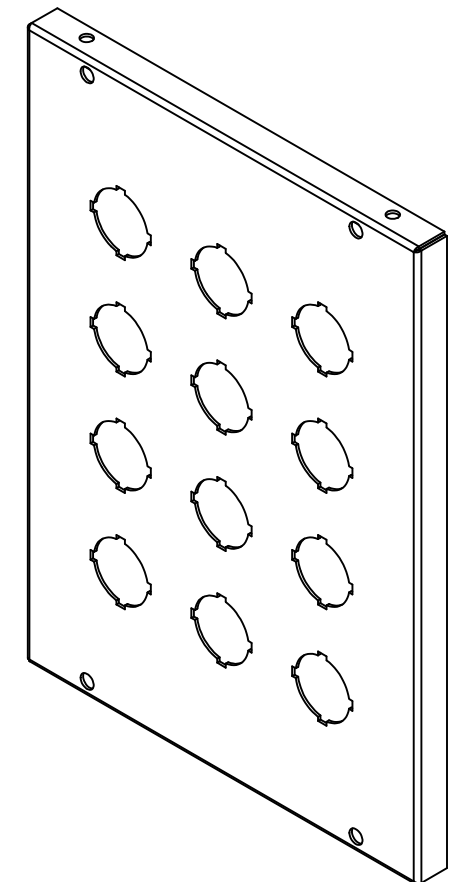

Isometric View

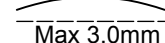

 Tél: (450) 979-4373 Fax: (450) 979-4626 www.exmweb.com		Flatness Aplatissement  Max 3.0mm
Customer Client		Date
Drawn By Dessiné Par BoxCad: patsan		Date 06/06/2013
Material Matière 16 Ga Stainless Steel 304 (1.4mm)		
Color Couleur Outside Unpainted and Inside White RAL9003	Finish Fini Brushed	
Description 1412SDSS 12.25" x 8.75" Cover		Detail Rev.
Part Number Numéro Pièce 1412SDSS110803C		Rev. 0

Qty	Part Number	Rev	Description
1	STK-P-02401S	0	Powder Paint (White / Smooth)
1	1412SDSS110803G	0	1412SDSS 12.25" x 8.75" Gasket
1	1412SDSS110803C-P	0	1412SDSS 12.25" x 8.75" Cover Part
Parts List			