

This drawing is confidential and must not be reproduced or used without the consent of EXM

Ce dessin est confidentiel et ne doit pas être reproduit ou utilisé sans le consentement de EXM

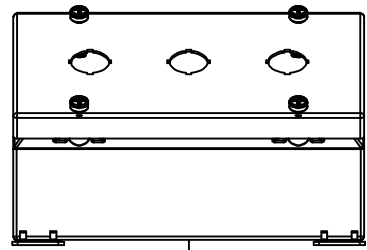

TOP

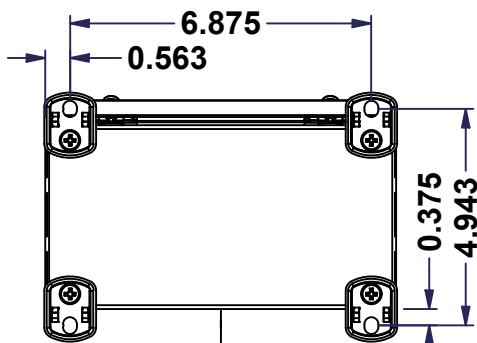

BACK

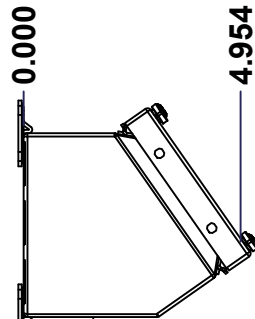

LEFT

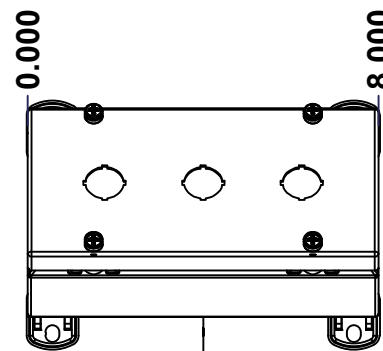

FRONT

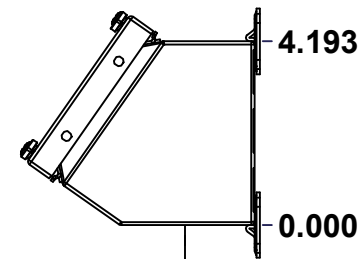

RIGHT

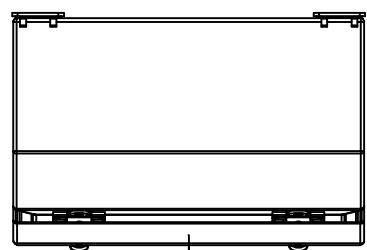

BOTTOM

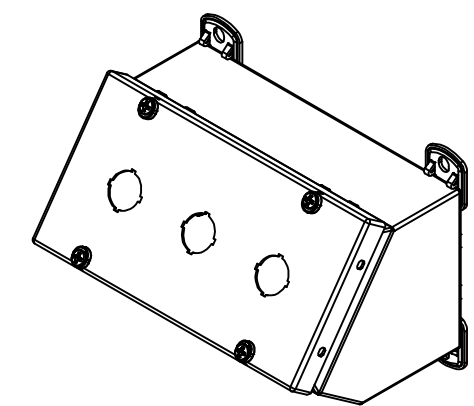

Isometric View

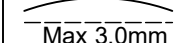
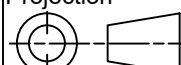

No.	Revisions	Date	By/Par

 Tél: (450) 979-4373 Fax: (450) 979-4626 www.exmweb.com		Flatness Aplatissement  Max 3.0mm Projection 
Customer Client		Date
Drawn By Dessiné Par	BoxCad: BoxCad	Date 16-Mar-23
Material Matière	16 Ga Cold Rolled A1008 CS Type B (1.4mm)	
Color Couleur	Asa-61 Grey	Finish Fini Smooth
Description 1412SFMN 4" x 8" x 4.814" Assembly		Detail Rev.
Part Number Numéro Pièce	1412SF030704MN	Rev. 1 0

SEE BILL OF MATERIAL ON LAST PAGE

This drawing is confidential and must not be reproduced or used without the consent of EXM

Ce dessin est confidentiel et ne doit pas être reproduit ou utilisé sans le consentement de EXM

NOTE	
ITEM	DESCRIPTION
1	NEMA 4/12 Enclosure
2	C/W Standard ground standoffs on box only
3	W/O Standard door stiffener
4	W/O Inner panel
5	W/O Inner panel mounting standoffs
6	C/W 885 ESCHMF1 Mounting Feet (Installed)

No.	Revisions	Date	By/Par

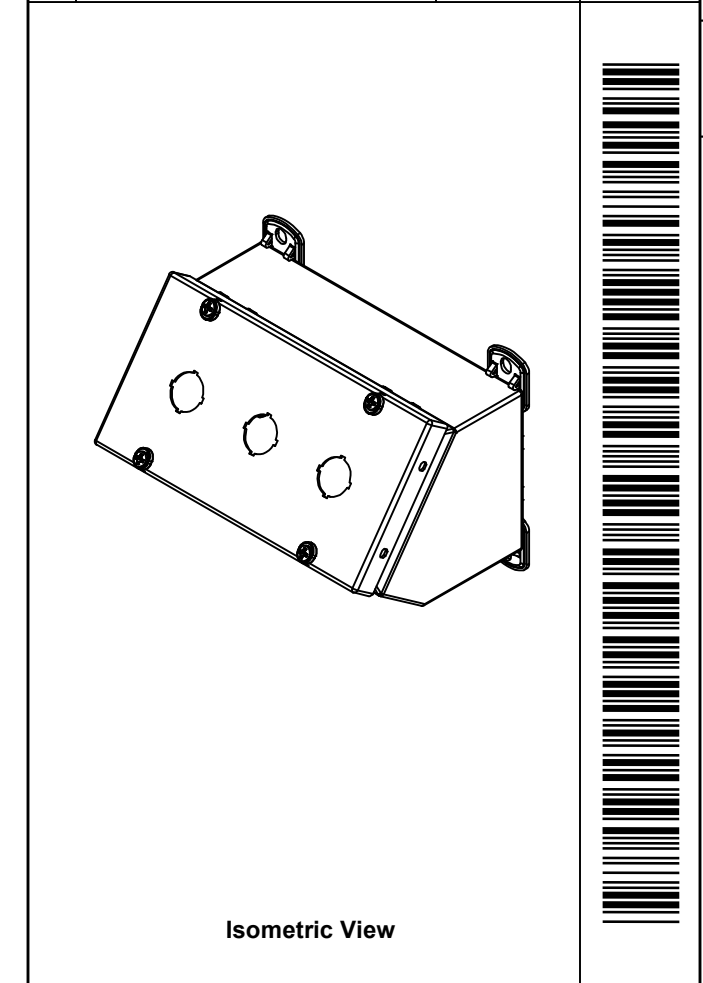

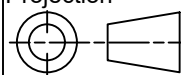
 Tél: (450) 979-4373 Fax: (450) 979-4626 www.exmweb.com	Flatness Aplatissement Max 3.0mm
	Projection 
Customer Client	Date
Drawn By Dessiné Par BoxCad: BoxCad	Date 16-Mar-23
Material Matière 16 Ga Cold Rolled A1008 CS Type B (1.4mm)	
Color Couleur Asa-61 Grey	Finish Fini Smooth

PACKING		
ITEM	QTY	DESCRIPTION
Cardboard sleeve	2	Top and Bottom
Cardboard strip	2	Between back of enclosure and inner panel
Plastic bag	1	To protect cover surface and inside gasket
Plastic strap - Black	2	To Squeeze the 2 cardboard sleeve together
Packaging label	1	White label with product number

Qty	Part Number	Rev	Description
1	885 ESSCHMFQ	0	5412 ESSCH Mounting Feet Accessory Kit
1	STK-K-02920	3	5412 ESSC Accessory Kit
1	1412SF030704MNC	0	1412SFMN 4" x 8" Cover
1	1412SF030704MNB	0	1412SFMN 4" x 8" x 4.814" Body
Parts List			

Description 1412SFMN 4" x 8" x 4.814" Assembly		Detail Rev.	
Part Number Numéro Pièce 1412SF030704MN		Rev. 0	2 9

This drawing is confidential and must not be reproduced or used without the consent of EXM

Ce dessin est confidentiel et ne doit pas être reproduit ou utilisé sans le consentement de EXM

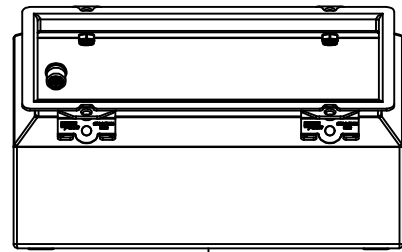

TOP

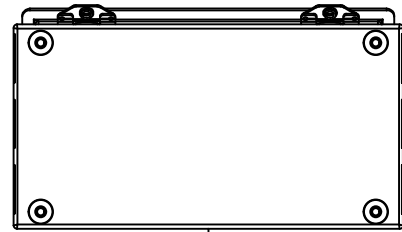

BACK

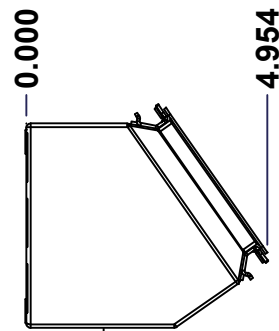

LEFT

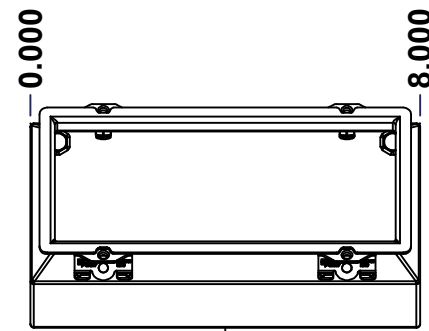

FRONT

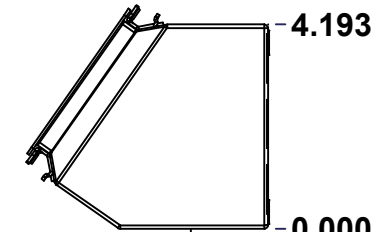

RIGHT

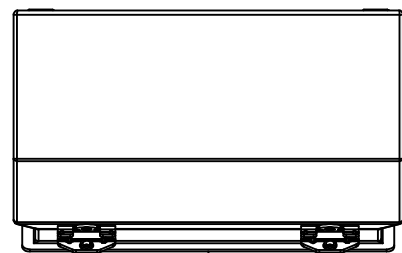

BOTTOM

No.	Revisions	Date	By/Par

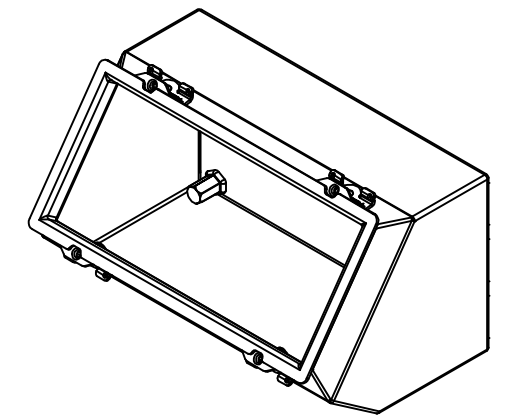

Isometric View



Tél: (450) 979-4373
 Fax: (450) 979-4626
www.exmweb.com

Flatness
Aplatissement

Max 3.0mm

Projection

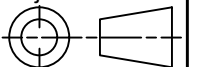

Customer Client	Date
Drawn By / Dessiné Par: BoxCad: BoxCad	Date: 16-Mar-23
Material / Matière: 16 Ga Cold Rolled A1008 CS Type B (1.4mm)	

Color / Couleur: Asa-61 Grey	Finish / Fini: Smooth
------------------------------	-----------------------

Description: 1412SFMN 4" x 8" x 4.814" Body	Detail Rev.
---	-------------

Part Number / Numéro Pièce: 1412SF030704MNB	Rev. 0	3 / 9
---	--------	-------

SEE BILL OF MATERIAL ON LAST PAGE

This drawing is confidential and must not be reproduced or used without the consent of EXM

Ce dessin est confidentiel et ne doit pas être reproduit ou utilisé sans le consentement de EXM

STANDARD FEATURES ARE NOT LISTED IN THIS HOLE TABLE

HOLE TABLE - BACK VIEW (CUSTOM FEATURE ONLY)

CUT-OUT	XDIM	YDIM	DESCRIPTION
1	7.437	0.000	FOOT 885 ESCHMF1
2	0.563	0.000	FOOT 885 ESCHMF1
3	7.437	4.161	FOOT 885 ESCHMF1
4	0.563	4.161	FOOT 885 ESCHMF1
5	7.437	0.344	RIVET NUT M6_FH_CE (Inside)
6	0.563	0.344	RIVET NUT M6_FH_CE (Inside)
7	7.437	3.817	RIVET NUT M6_FH_CE (Inside)
8	0.563	3.817	RIVET NUT M6_FH_CE (Inside)

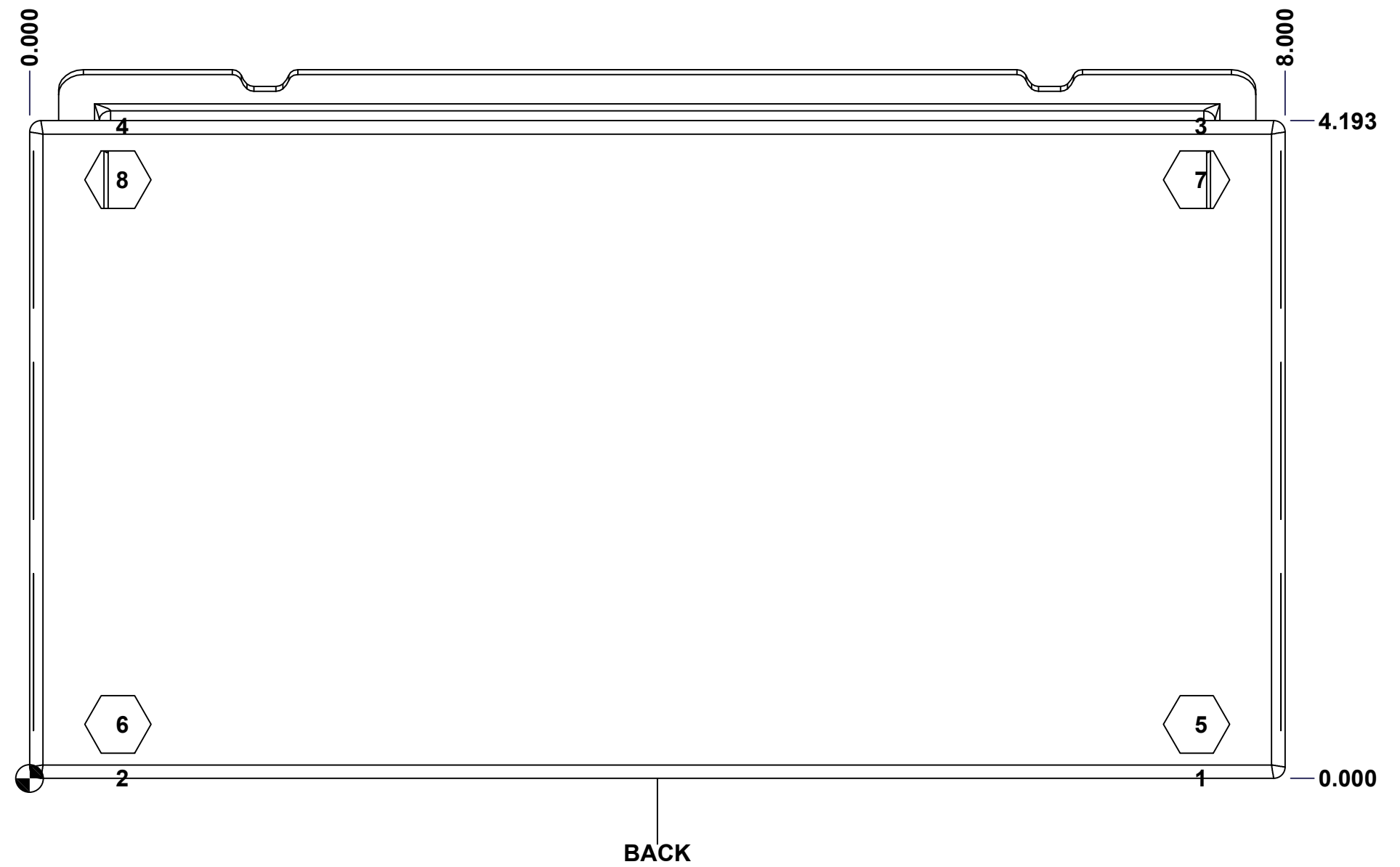

	Description	Status	
	1412SFMN 4" x 8" x 4.814" Body	(NULL)	
Part Number Numéro Pièce 1412SF030704MNB	Rev.	4	9
	0		

This drawing is confidential and must not be reproduced or used without the consent of EXM

Ce dessin est confidentiel et ne doit pas être reproduit ou utilisé sans le consentement de EXM

STANDARD FEATURES ARE NOT LISTED IN THIS HOLE TABLE			
HOLE TABLE - ANGLE VIEW (CUSTOM FEATURE ONLY)			
CUT-OUT	XDIM	YDIM	DESCRIPTION
1	7.125	0.742	STANDOFF M6 x 10mm (Inside)

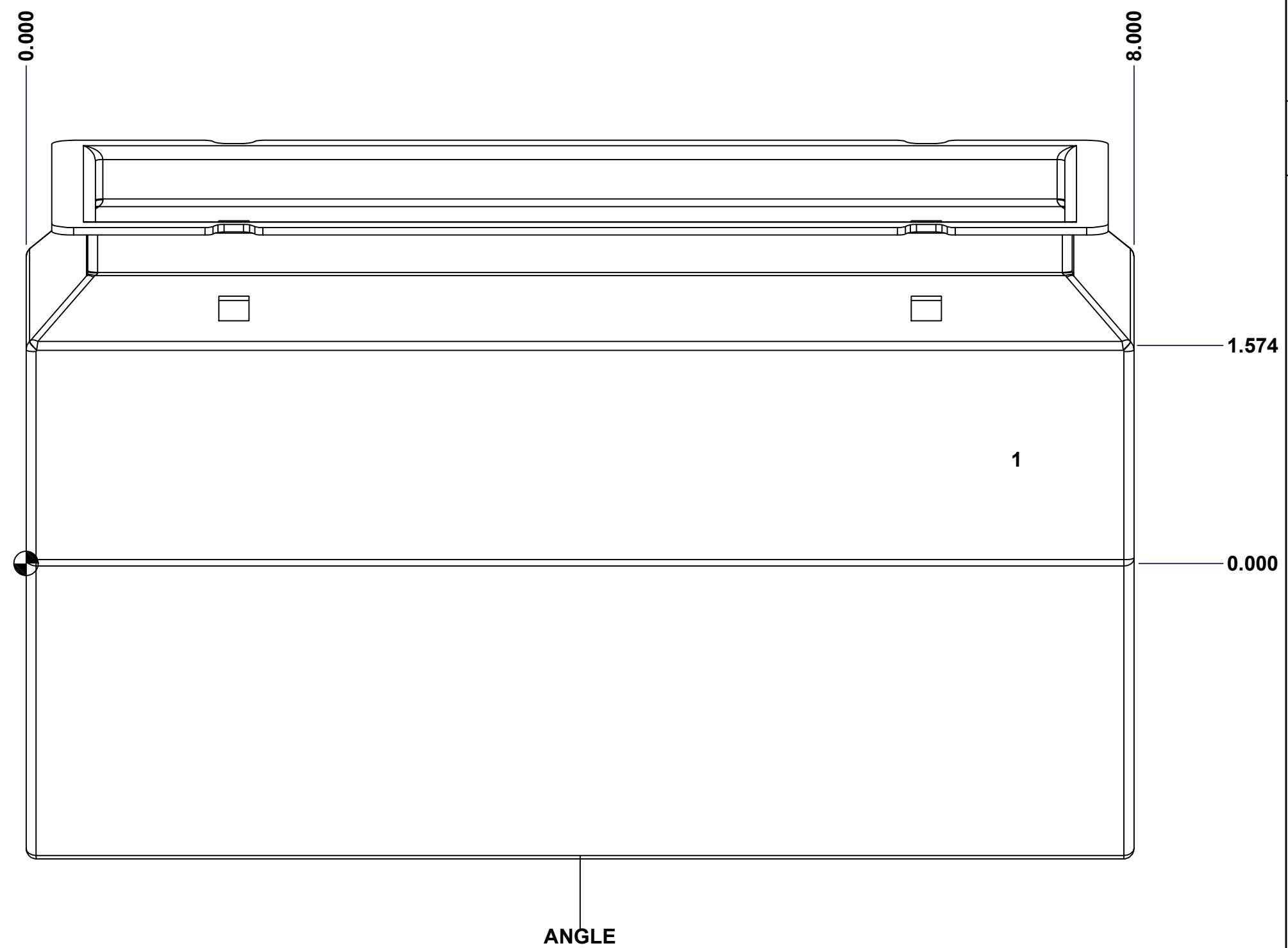

	Description	Status
	1412SFMN 4" x 8" x 4.814" Body	(NULL)
Part Number Numéro Pièce 1412SF030704MNB	Rev.	5
	0	9

This drawing is confidential and must not be reproduced or used without the consent of EXM

Ce dessin est confidentiel et ne doit pas être reproduit ou utilisé sans le consentement de EXM

No.	Revisions	Date	By/Par

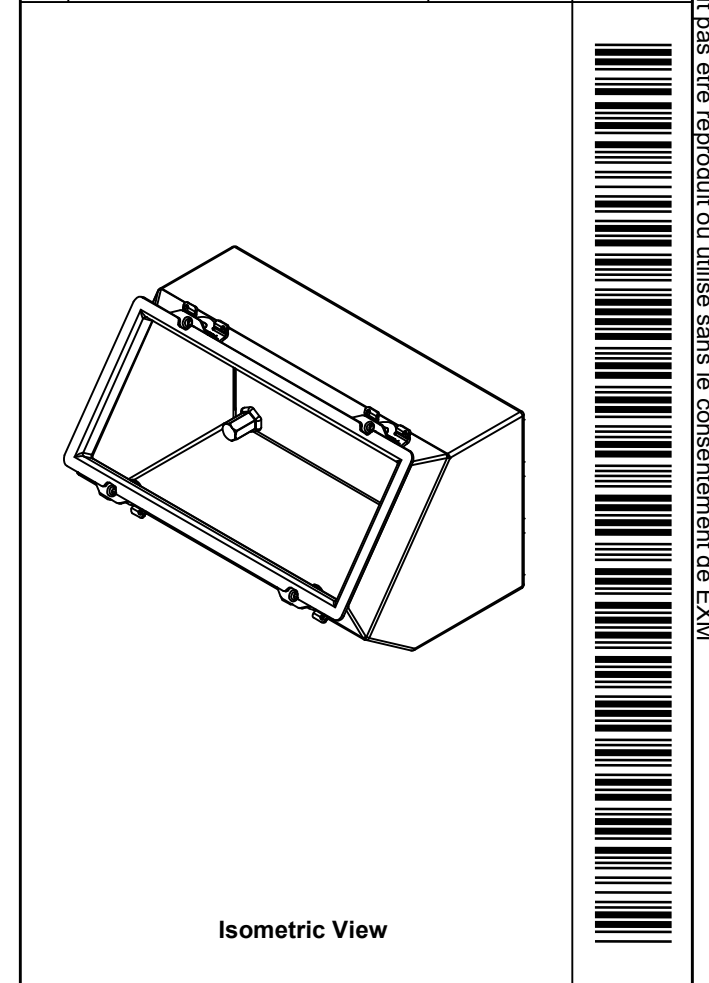

EXM
exm

Tél: (450) 979-4373
Fax: (450) 979-4626
www.exmweb.com

Flatness
Aplatissement
Max 3.0mm

Projection

Customer Client _____ Date _____

Drawn By / Dessiné Par BoxCad: BoxCad Date 16-Mar-23

Material / Matière 16 Ga Cold Rolled A1008 CS Type B (1.4mm)

Color / Couleur Asa-61 Grey Finish / Fini Smooth

Description 1412SFMN 4" x 8" x 4.814" Body

Detail Rev. _____

Part Number / Numéro Pièce **1412SF030704MNB**

Rev. **0**

6
9

4	RIVET_NUT_M6_FH_CE	0	Rivet Nut M6 (Low Profile Close End)
1	STK-Q-08350	5	Standoff M6 x 10mm
1	STK-P-02400S	0	Powder Paint (Asa-61 Grey / Smooth)
1	1412SF030704MNB-P	0	1412SFMN 4" x 8" x 4.814" Body Part
4	STK-Q-70464	2	5412 ESSC & ESSSC Stainless Steel Body Catch Assembly
4	STK-Q-08100	1	M5 Nylon Insert Lock Nut
Qty	Part_Number	Rev	Description
Parts List			

This drawing is confidential and must not be reproduced or used without the consent of EXM

Ce dessin est confidentiel et ne doit pas être reproduit ou utilisé sans le consentement de EXM

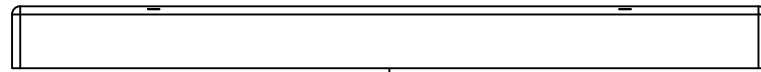

TOP

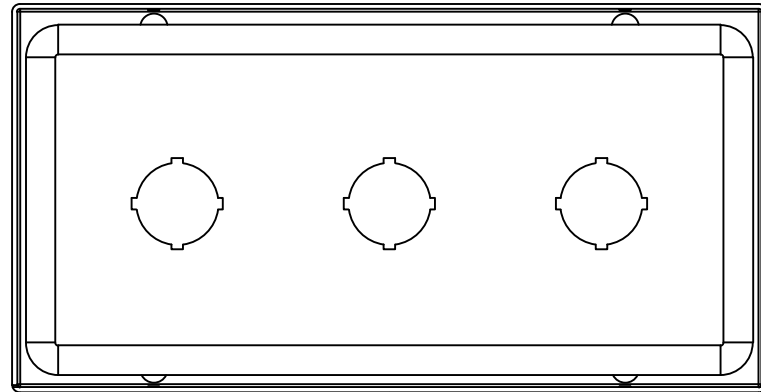

BACK

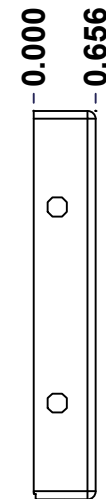

LEFT

0.000

0.656

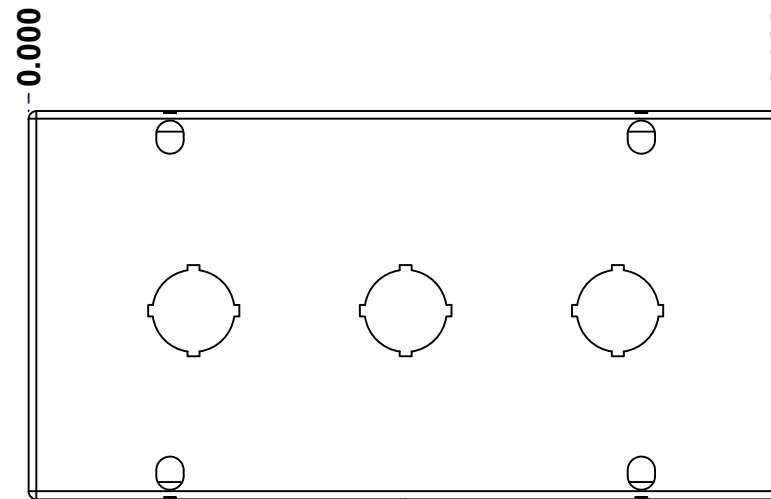

FRONT

0.000

8.000

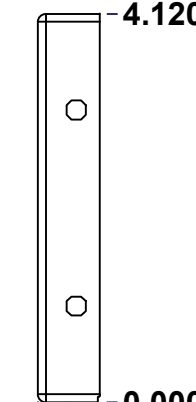

RIGHT

4.120

0.000

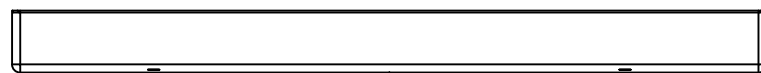

BOTTOM

No.	Revisions	Date	By/Par

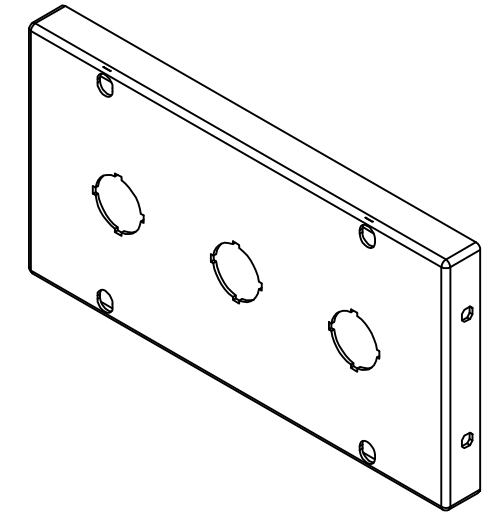

Isometric View



Tél: (450) 979-4373
 Fax: (450) 979-4626
www.exmweb.com

Flatness
Aplatissement

Max 3.0mm

Projection

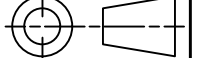

Customer Client	Date
Drawn By / Dessiné Par: BoxCad: BoxCad	Date: 16-Mar-23
Material / Matière: 16 Ga Cold Rolled A1008 CS Type B (1.4mm)	

Color / Couleur: Asa-61 Grey	Finish / Fini: Smooth
------------------------------	-----------------------

Description: 1412SFMN 4" x 8" Cover	Detail Rev.
-------------------------------------	-------------

Part Number / Numéro Pièce: 1412SF030704MNC	Rev. 0	7 / 9
---	--------	-------

SEE BILL OF MATERIAL ON LAST PAGE

This drawing is confidential and must not be reproduced or used without the consent of EXM

Ce dessin est confidentiel et ne doit pas être reproduit ou utilisé sans le consentement de EXM

STANDARD FEATURES ARE NOT LISTED IN THIS HOLE TABLE			
HOLE TABLE - FRONT VIEW (CUSTOM FEATURE ONLY)			
CUT-OUT	XDIM	YDIM	DESCRIPTION
1	6.250	2.000	22.5 mm Miniature Pushbutton
2	4.000	2.000	22.5 mm Miniature Pushbutton
3	1.750	2.000	22.5 mm Miniature Pushbutton

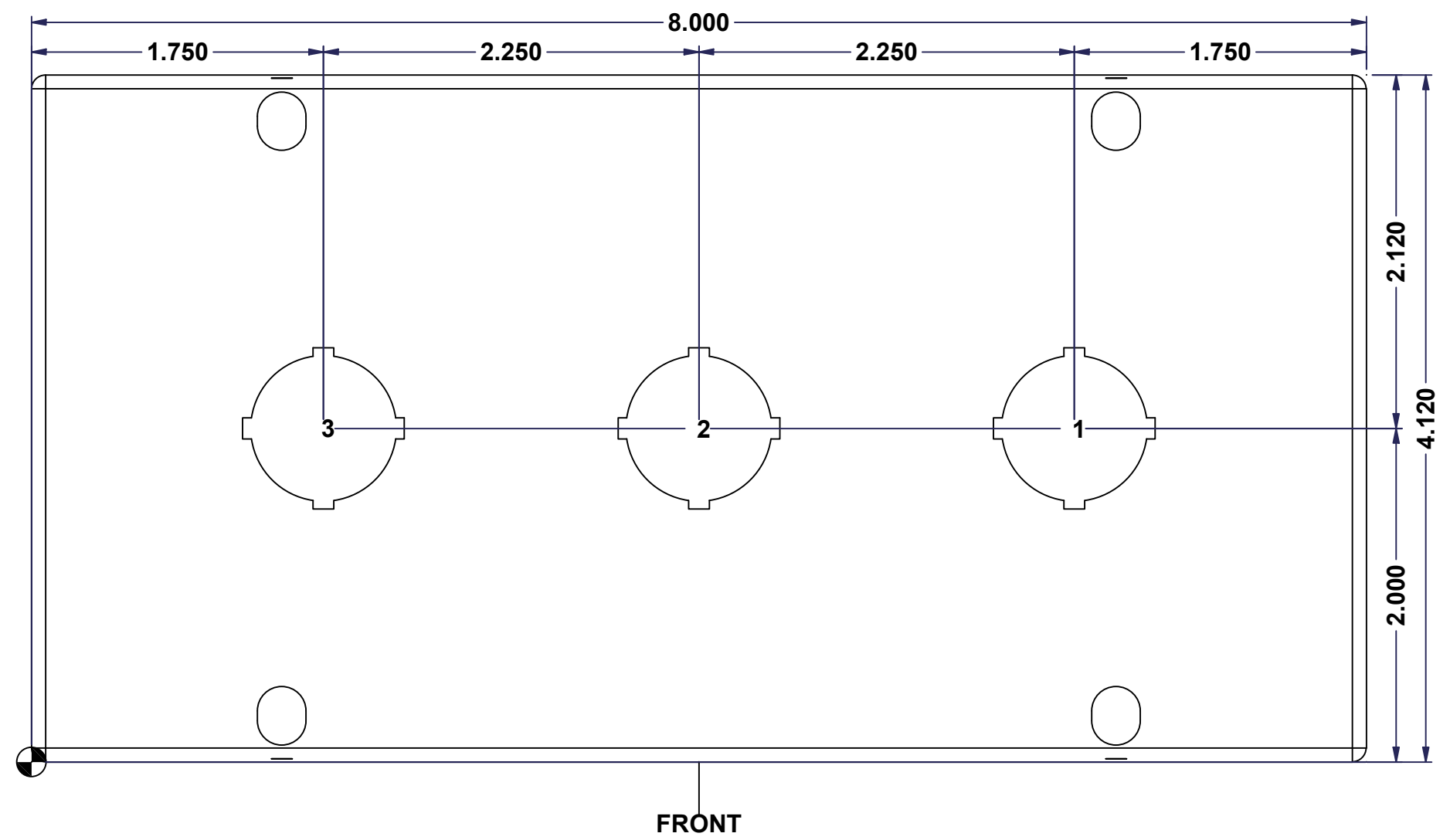

	Description	Status	
	1412SFMN 4" x 8" Cover	(NULL)	
	Part Number Numéro Pièce	Rev.	
	1412SF030704MNC	0	8 9

This drawing is confidential and must not be reproduced or used without the consent of EXM

Ce dessin est confidentiel et ne doit pas être reproduit ou utilisé sans le consentement de EXM

No.	Revisions	Date	By/Par

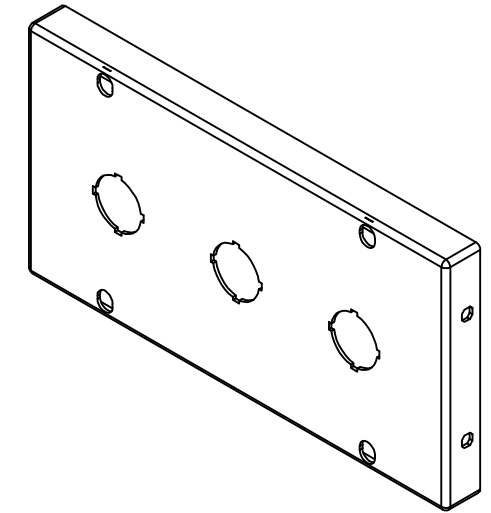

Isometric View

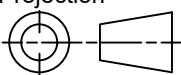

 Tél: (450) 979-4373 Fax: (450) 979-4626 www.exmweb.com		Flatness Aplatissement Max 3.0mm Projection 
Customer Client	Date	
Drawn By Dessiné Par	BoxCad: BoxCad	Date 16-Mar-23
Material Matière	16 Ga Cold Rolled A1008 CS Type B (1.4mm)	
Color Couleur	Asa-61 Grey	Finish Fini Smooth
Description		Detail Rev.
1412SFMN 4" x 8" Cover		
Part Number Numéro Pièce	Rev.	9
1412SF030704MNC	0	9

Qty	Part Name	Rev	Description
1	1412SF030704MNG	0	1412SF 4" x 8" Gasket
1	1412SF030704MNC-P	0	1412SFMN 4" x 8" Cover Part
1	STK-P-02400S	0	Powder Paint (Asa-61 Grey / Smooth)
Parts List			