

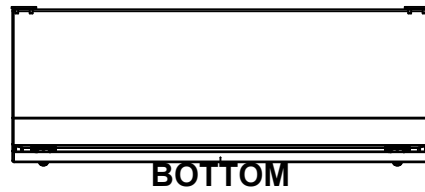

This drawing is confidential and must not be reproduced or used without the consent of EXM

Ce dessin est confidentiel et ne doit pas être reproduit ou utilisé sans le consentement de EXM

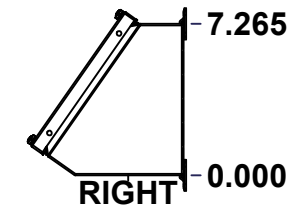
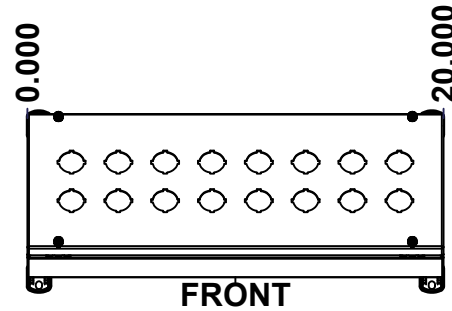
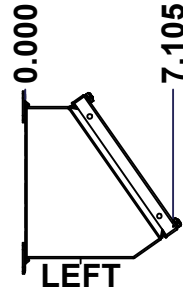
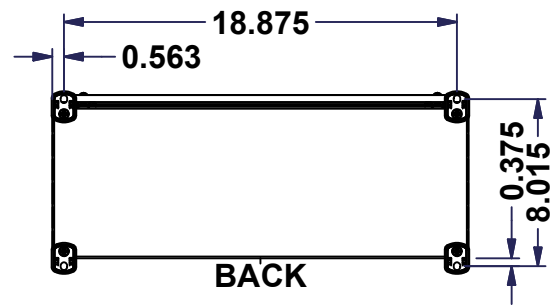
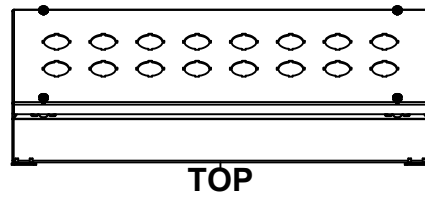
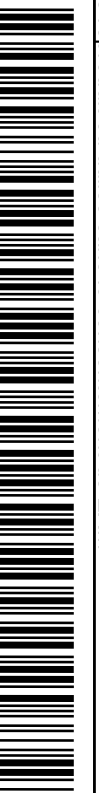
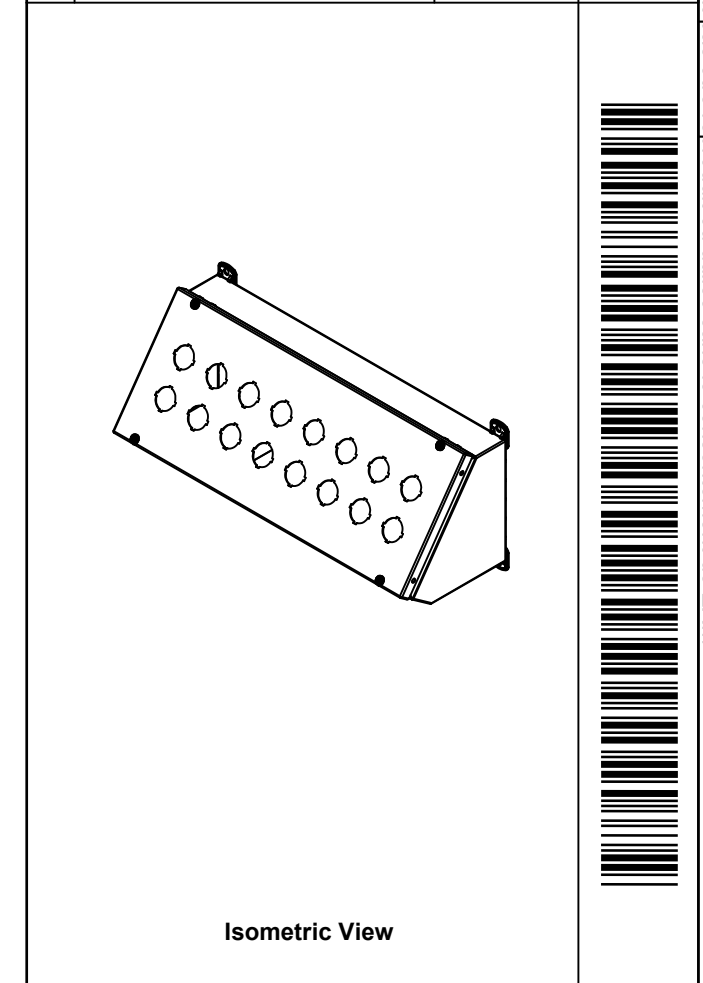

No.	Revisions	Date	By/Par



 Tél: (450) 979-4373 Fax: (450) 979-4626 www.exmweb.com		Flatness Aplatissement	
		Max 3.0mm	
Customer Client		Date	
Drawn By Dessiné Par BoxCad: BoxCad		Date 10/15/2019	
Material Matière 16 Ga Cold Rolled A1008 CS Type B (1.4mm)			
Color Couleur Asa-61 Grey		Finish Fini Smooth	
Description 1412SF 7.75" x 20" x 6.965" Assembly			Detail Rev.
Part Number Numéro Pièce 1412SF071906		Rev. 0	1 2

SEE BILL OF MATERIAL ON LAST PAGE

This drawing is confidential and must not be reproduced or used without the consent of EXM

Ce dessin est confidentiel et ne doit pas être reproduit ou utilisé sans le consentement de EXM

NOTE	
ITEM	DESCRIPTION
1	NEMA 4/12 Enclosure
2	C/W Standard ground standoffs on box and cover
3	W/O Standard door stiffener
4	W/O Inner panel
5	W/O Inner panel mounting standoffs
6	C/W 885 ESCHMF1 Mounting Feet (Installed)

No.	Revisions	Date	By/Par

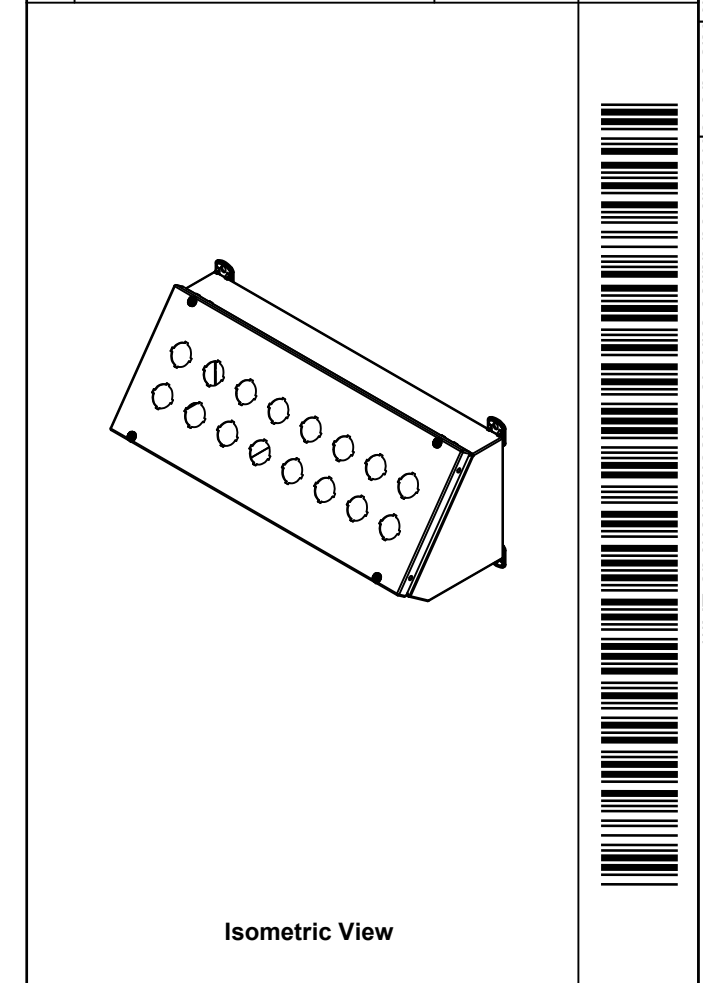

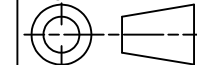
 Tél: (450) 979-4373 Fax: (450) 979-4626 www.exmweb.com		Flatness Aplatissement Max 3.0mm Projection 
Customer Client	Date	
Drawn By Dessiné Par	BoxCad: BoxCad	Date 10/15/2019
Material Matière	16 Ga Cold Rolled A1008 CS Type B (1.4mm)	
Color Couleur	Asa-61 Grey	Finish Fini Smooth
Description	Detail Rev.	
1412SF 7.75" x 20" x 6.965" Assembly		Rev. 2
Part Number Numéro Pièce	1412SF071906	0

PACKING		
ITEM	QTY	DESCRIPTION
Cardboard sleeve	2	Top and Bottom
Cardboard strip	2	Between back of enclosure and inner panel
Plastic bag	1	To protect cover surface and inside gasket
Plastic strap - Black	2	To Squeeze the 2 cardboard sleeve together
Packaging label	1	White label with product number

Qty	Part Number	Rev	Description
1	885 ESSCHMFQ	0	5412 ESSCH Mounting Feet Accessory Kit
1	STK-K-02920	3	5412 ESSC Accessory Kit
1	1412SF071906C	0	1412SF 7.75" x 20" Cover
1	1412SF071906B	0	1412SF 7.75" x 20" x 6.965" Body
Parts List			

This drawing is confidential and must not be reproduced or used without the consent of EXM

Ce dessin est confidentiel et ne doit pas être reproduit ou utilisé sans le consentement de EXM

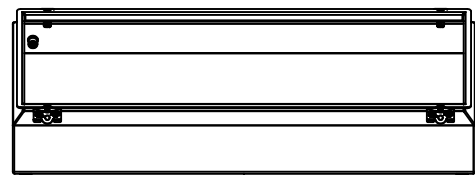

TOP



BACK

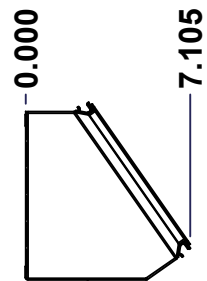

LEFT



FRONT

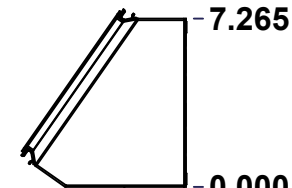

RIGHT

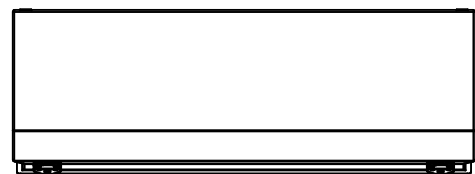

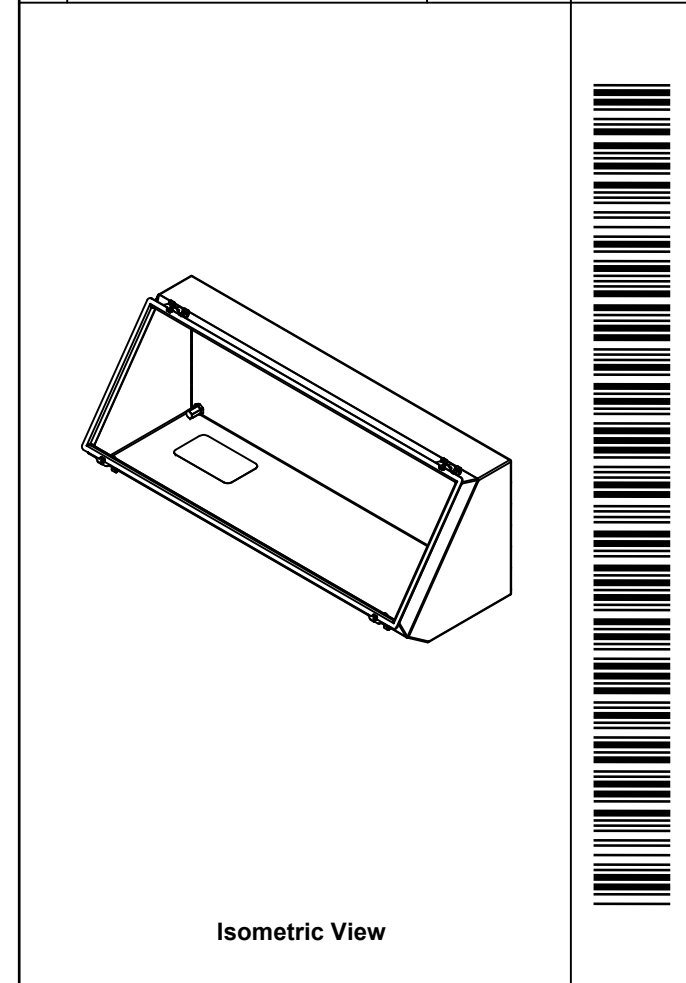

BOTTOM

No.	Revisions	Date	By/Par

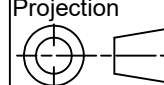

Isometric View

 Tél: (450) 979-4373 Fax: (450) 979-4626 www.exmweb.com		Flatness Aplatissement  Max 3.0mm Projection 
Customer Client	Date	
Drawn By Dessiné Par	BoxCad: BoxCad	Date 10/15/2019
Material Matière	16 Ga Cold Rolled A1008 CS Type B (1.4mm)	
Color Couleur	Asa-61 Grey	Finish Fini Smooth
Description	Detail Rev.	
1412SF 7.75" x 20" x 6.965" Body		
Part Number Numéro Pièce	Rev.	1 / 7
1412SF071906B	0	

SEE BILL OF MATERIAL ON LAST PAGE

This drawing is confidential and must not be reproduced or used without the consent of EXM

Ce dessin est confidentiel et ne doit pas être reproduit ou utilisé sans le consentement de EXM

STANDARD FEATURES ARE NOT LISTED IN THIS HOLE TABLE			
HOLE TABLE - ANGLE VIEW (CUSTOM FEATURE ONLY)			
CUT-OUT	XDIM	YDIM	DESCRIPTION
1	19.125	0.742	STANDOFF M6 x 10mm (Inside)

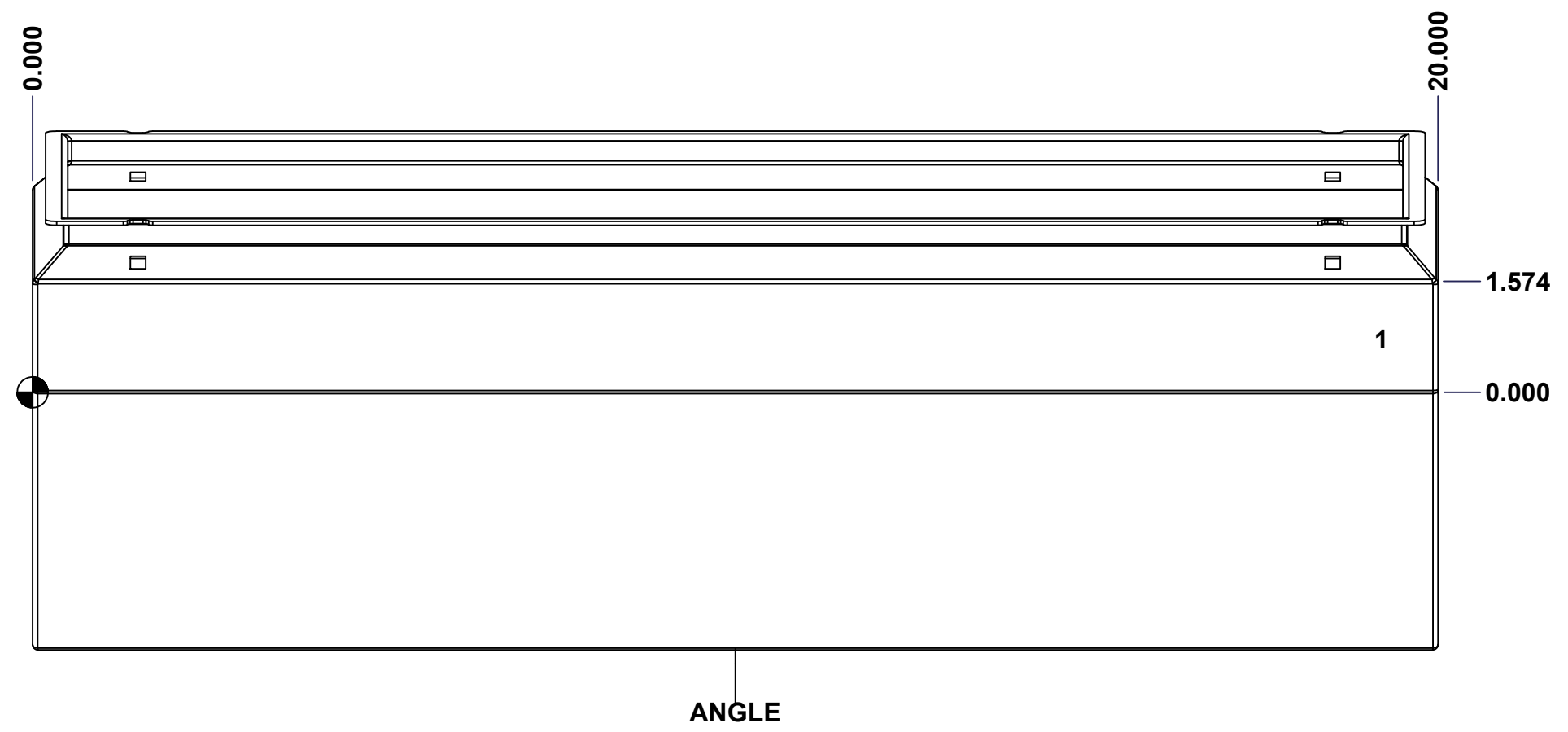

	Description		Status	
	1412SF 7.75" x 20" x 6.965" Body		(NULL)	
Part Number Numéro Pièce		Rev.	4	
1412SF071906B		0	7	

This drawing is confidential and must not be reproduced or used without the consent of EXM

Ce dessin est confidentiel et ne doit pas être reproduit ou utilisé sans le consentement de EXM

STANDARD FEATURES ARE NOT LISTED IN THIS HOLE TABLE

HOLE TABLE - BACK VIEW (CUSTOM FEATURE ONLY)

CUT-OUT	XDIM	YDIM	DESCRIPTION
1	19.437	0.000	FOOT 885 ESCHMF1
2	0.563	0.000	FOOT 885 ESCHMF1
3	19.437	7.233	FOOT 885 ESCHMF1
4	0.563	7.233	FOOT 885 ESCHMF1
5	19.437	0.344	RIVET NUT M6_FH_CE (Inside)
6	0.563	0.344	RIVET NUT M6_FH_CE (Inside)
7	19.437	6.889	RIVET NUT M6_FH_CE (Inside)
8	0.563	6.889	RIVET NUT M6_FH_CE (Inside)

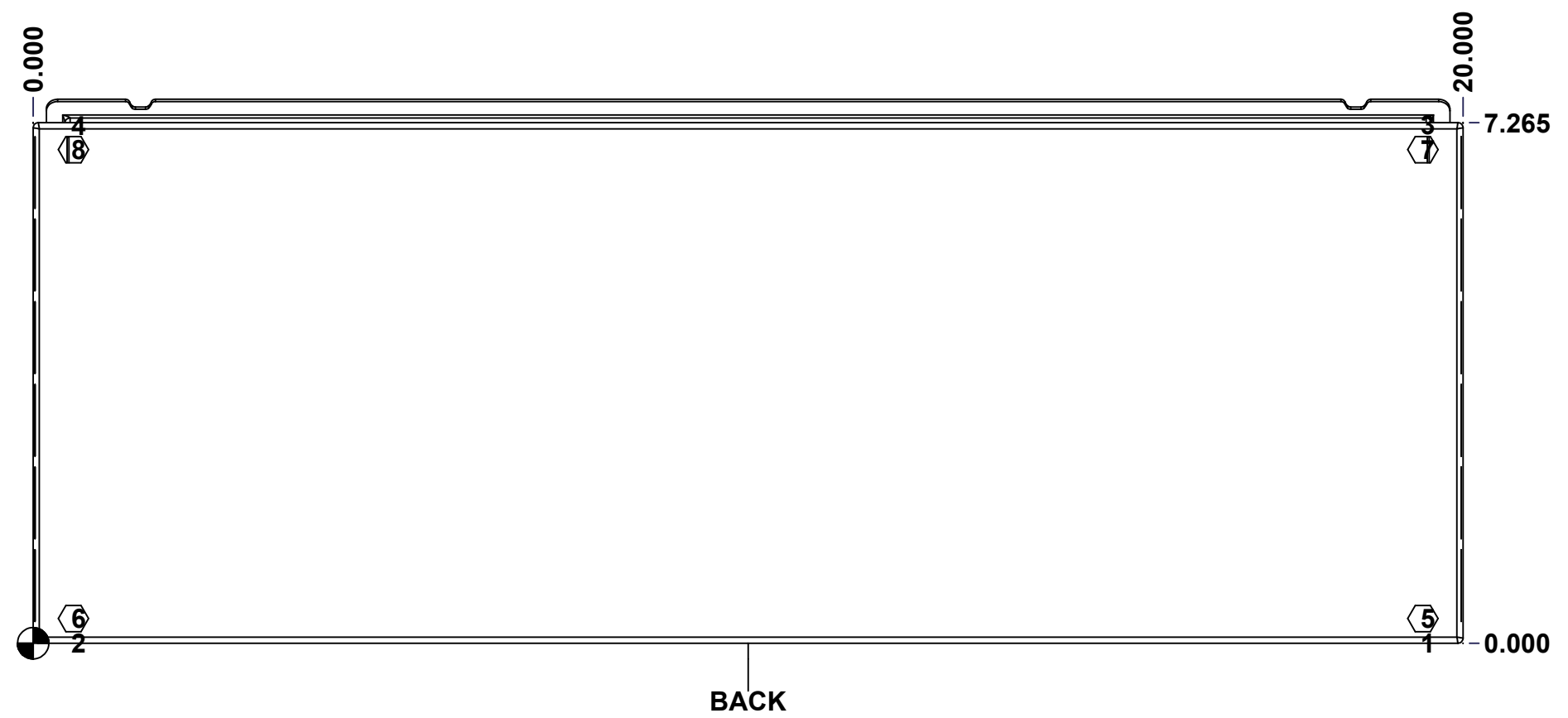



	Description	Status	
	1412SF 7.75" x 20" x 6.965" Body	(NULL)	
	Part Number Numéro Pièce	Rev.	
	1412SF071906B	0	6 / 7

This drawing is confidential and must not be reproduced or used without the consent of EXM

Ce dessin est confidentiel et ne doit pas être reproduit ou utilisé sans le consentement de EXM

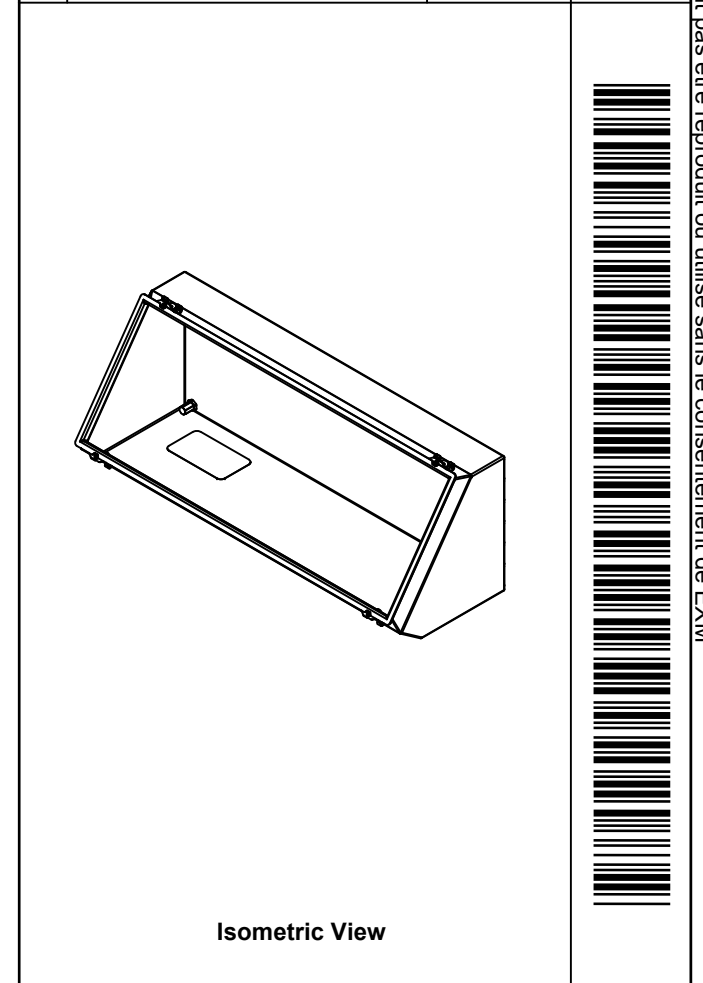
No.	Revisions	Date	By/Par

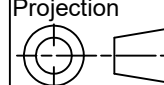

 Tél: (450) 979-4373 Fax: (450) 979-4626 www.exmweb.com		Flatness Aplatissement  Max 3.0mm
Projection 		
Customer Client		Date
Drawn By / Dessiné Par: BoxCad: BoxCad		Date: 10/15/2019
Material / Matière: 16 Ga Cold Rolled A1008 CS Type B (1.4mm)		
Color / Couleur: Asa-61 Grey	Finish / Fini: Smooth	
Description: 1412SF 7.75" x 20" x 6.965" Body		Detail Rev.
Part Number / Numéro Pièce: 1412SF071906B		Rev. 7
		0 / 7

4	RIVET_NUT_M6_FH_CE	0	Rivet Nut M6 (Low Profile Close End)
1	STK-Q-08350	5	Standoff M6 x 10mm
1	STK-P-02400S	0	Powder Paint (Asa-61 Grey / Smooth)
1	STK-S-00100	0	3.5" x 2" Silver Milar Flexcon Sticker
1	1412SF071906B-P	0	1412SF 7.75" x 20" x 6.965" Body Part
4	STK-Q-70464	2	5412 ESSC & ESSSC Stainless Steel Body Catch Assembly
4	STK-Q-08100	1	M5 Nylon Insert Lock Nut
Qty	Part_Number	Rev	Description
Parts List			

This drawing is confidential and must not be reproduced or used without the consent of EXM

Ce dessin est confidentiel et ne doit pas être reproduit ou utilisé sans le consentement de EXM

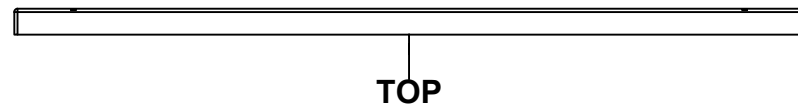

TOP

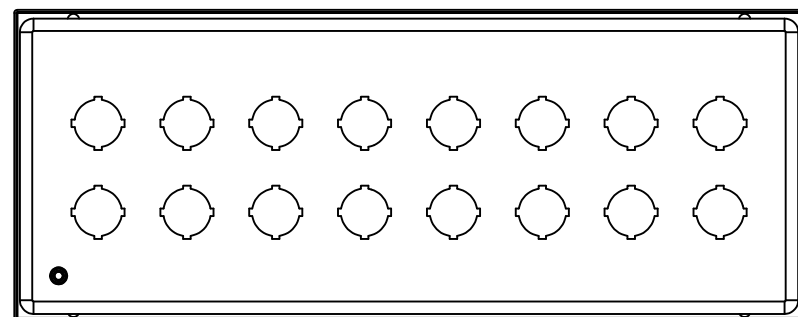

BACK

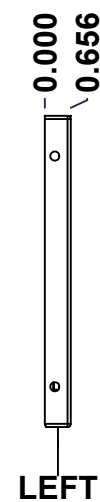

LEFT

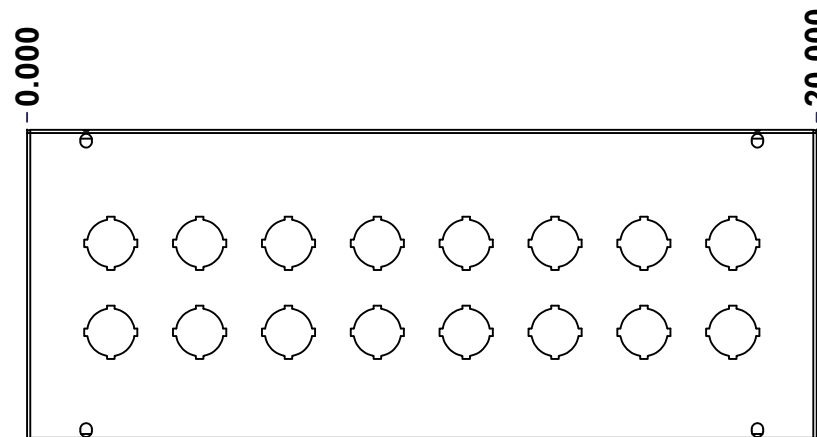

FRONT

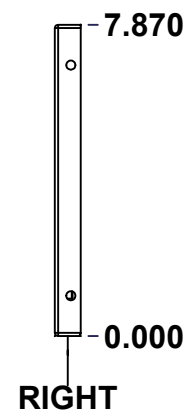

RIGHT

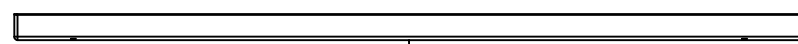

BOTTOM

No.	Revisions	Date	By/Par

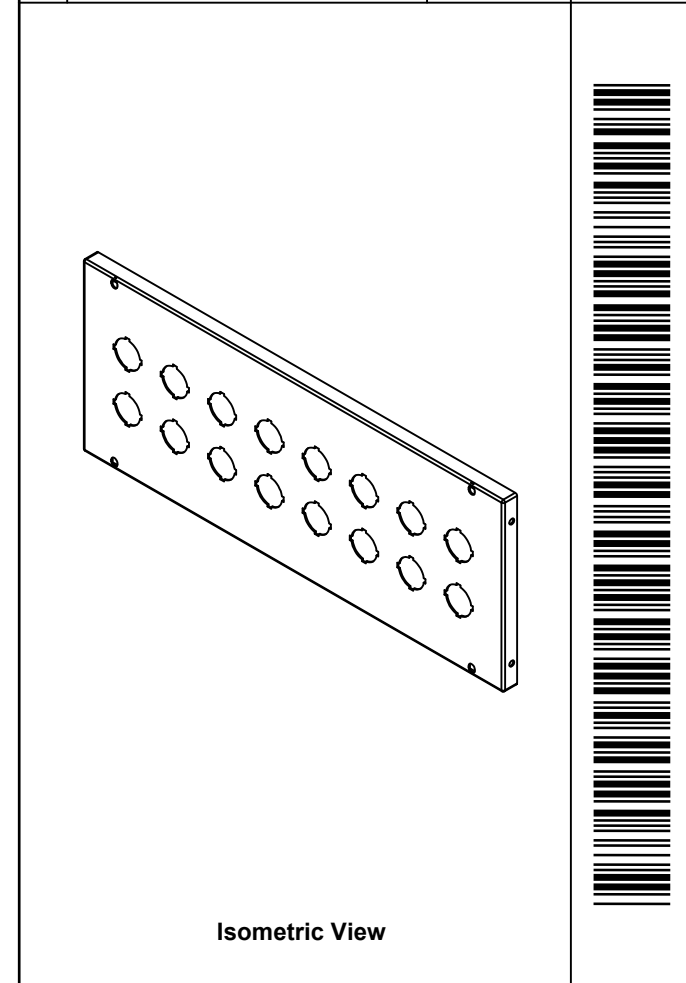

Isometric View



Tél: (450) 979-4373
 Fax: (450) 979-4626
www.exmweb.com

Flatness
Aplatissement

Max 3.0mm

Projection

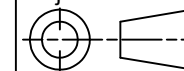

Customer Client	Date
Drawn By / Dessiné Par: BoxCad: BoxCad	Date: 10/15/2019

Material / Matière: 16 Ga Cold Rolled A1008 CS Type B (1.4mm)

Color / Couleur: Asa-61 Grey Finish / Fini: Smooth

Description: 1412SF 7.75" x 20" Cover Detail Rev.

Part Number / Numéro Pièce: 1412SF071906C	Rev. 0	1 / 3
---	--------	-------

SEE BILL OF MATERIAL ON LAST PAGE

This drawing is confidential and must not be reproduced or used without the consent of EXM

Ce dessin est confidentiel et ne doit pas être reproduit ou utilisé sans le consentement de EXM

STANDARD FEATURES ARE NOT LISTED IN THIS HOLE TABLE

HOLE TABLE - FRONT VIEW (CUSTOM FEATURE ONLY)

CUT-OUT	XDIM	YDIM	DESCRIPTION
1	17.875	5.000	30.5 mm Standard Pushbutton
2	15.625	5.000	30.5 mm Standard Pushbutton
3	13.375	5.000	30.5 mm Standard Pushbutton
4	11.125	5.000	30.5 mm Standard Pushbutton
5	8.875	5.000	30.5 mm Standard Pushbutton
6	6.625	5.000	30.5 mm Standard Pushbutton
7	4.375	5.000	30.5 mm Standard Pushbutton
8	2.125	5.000	30.5 mm Standard Pushbutton
9	17.875	2.750	30.5 mm Standard Pushbutton
10	15.625	2.750	30.5 mm Standard Pushbutton
11	13.375	2.750	30.5 mm Standard Pushbutton
12	11.125	2.750	30.5 mm Standard Pushbutton
13	8.875	2.750	30.5 mm Standard Pushbutton
14	6.625	2.750	30.5 mm Standard Pushbutton
15	4.375	2.750	30.5 mm Standard Pushbutton
16	2.125	2.750	30.5 mm Standard Pushbutton
17	18.875	1.145	STANDOFF M6 x 10mm (Inside)

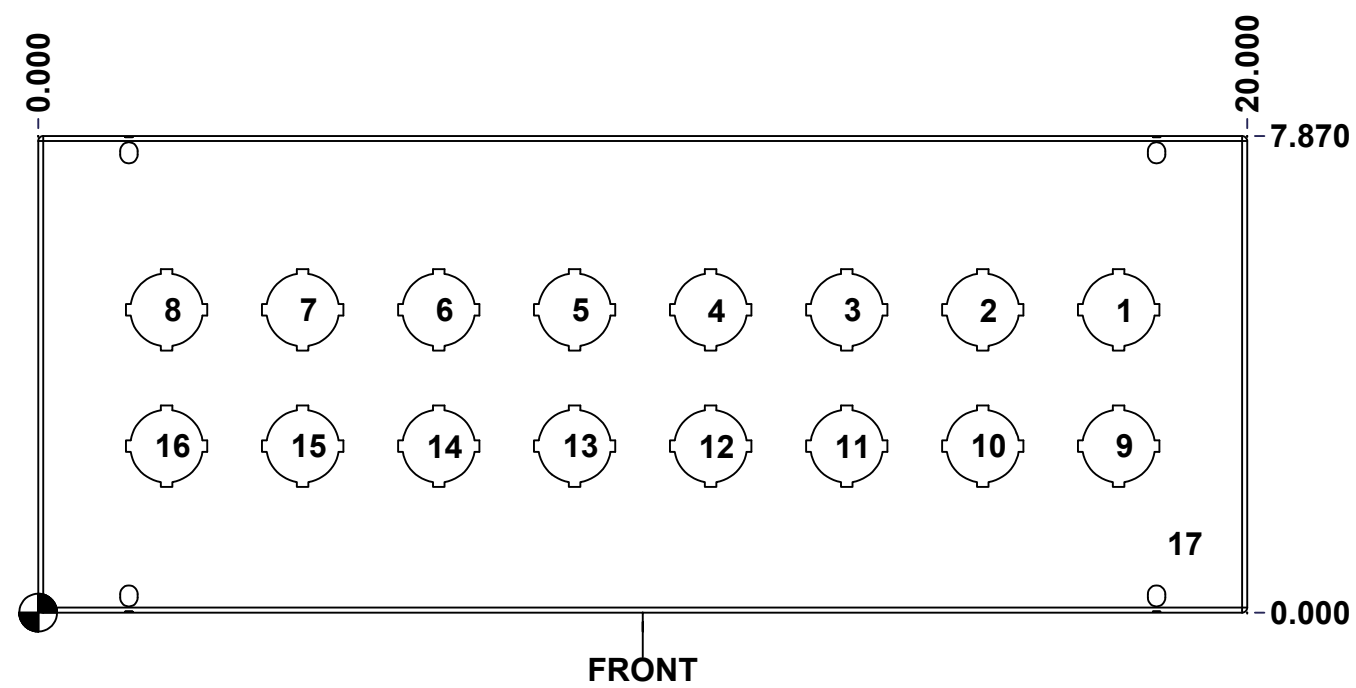



	Description	Status	
	1412SF 7.75" x 20" Cover	(NULL)	
	Part Number Numéro Pièce	Rev.	
	1412SF071906C	0	2 3

This drawing is confidential and must not be reproduced or used without the consent of EXM

Ce dessin est confidentiel et ne doit pas être reproduit ou utilisé sans le consentement de EXM

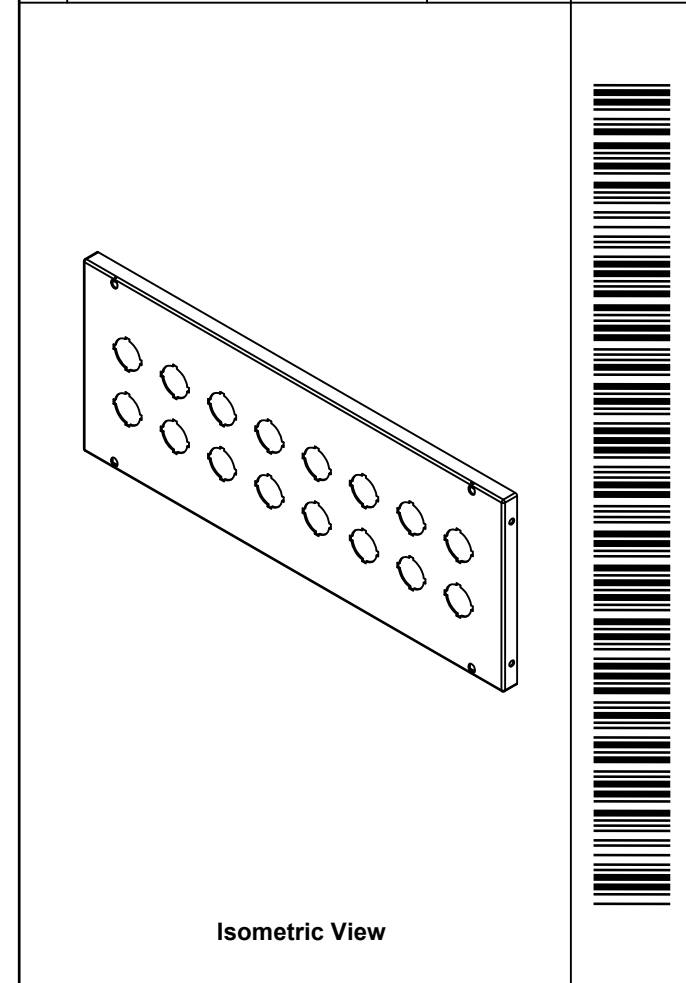
No.	Revisions	Date	By/Par

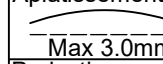
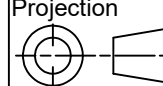

 Tél: (450) 979-4373 Fax: (450) 979-4626 www.exmweb.com		Flatness Aplatissement  Max 3.0mm Projection 
Customer Client	Date	
Drawn By Dessiné Par	BoxCad: BoxCad	Date 10/15/2019
Material Matière	16 Ga Cold Rolled A1008 CS Type B (1.4mm)	
Color Couleur	Asa-61 Grey	Finish Fini Smooth
Description	Detail Rev.	
1412SF 7.75" x 20" Cover		
Part Number Numéro Pièce	Rev.	3
1412SF071906C	0	3

Qty	Part Name	Rev	Description
1	STK-Q-08350	5	Standoff M6 x 10mm
1	1412SF071906G	0	1412SF 7.75" x 20" Gasket
1	1412SF071906C-P	0	1412SF 7.75" x 20" Cover Part
1	STK-P-02400S	0	Powder Paint (Asa-61 Grey / Smooth)
Parts List			