

This drawing is confidential and must not be reproduced or used without the consent of EXM

Ce dessin est confidentiel et ne doit pas être reproduit ou utilisé sans le consentement de EXM

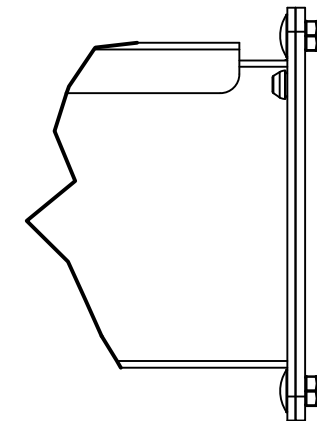
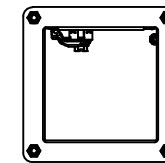
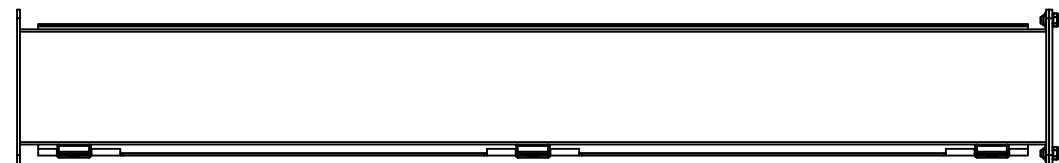
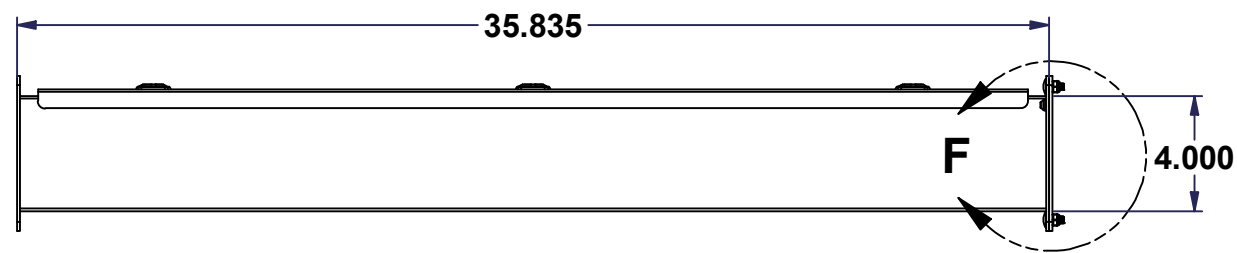
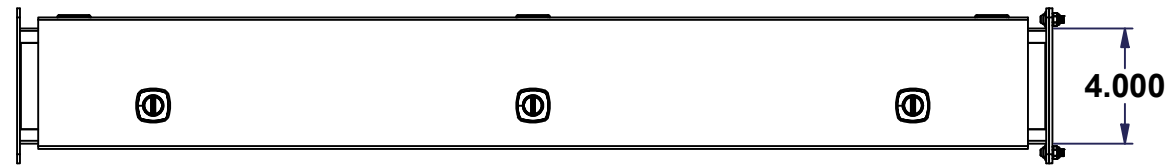

Isometric View

DETAIL F

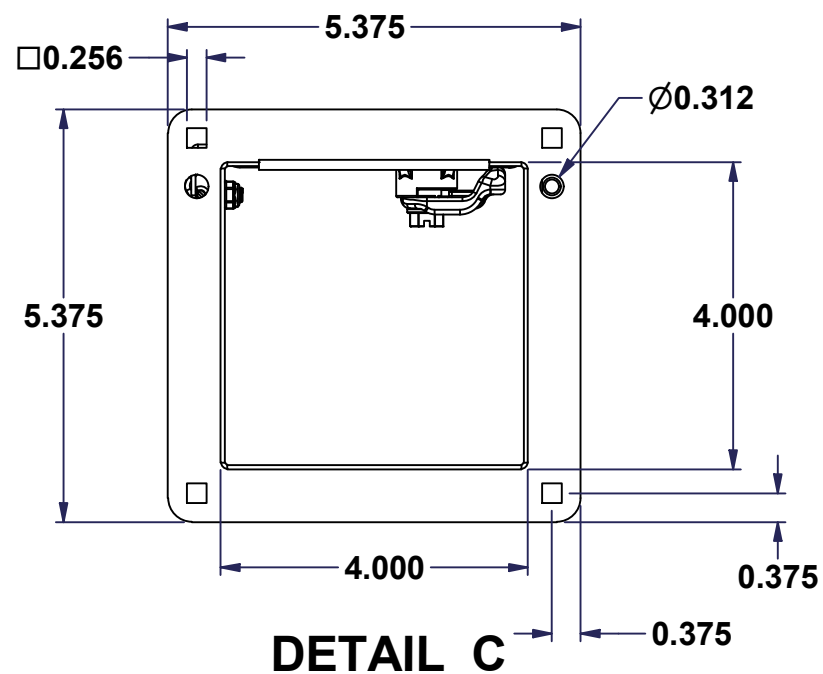

DETAIL C

1	1412SS4036G	0	1412 SS - Cover Gasket
3	STK-K-12520	4	1/4 Turn for 1500 CH Throughs - Lock Assembly
4	STK-Q-07225	0	M6 Stainless Steel Nylon Insert Lock Nut
4	STK-Q-00266	0	M6 x 16mm Stainless Steel 316 Carriage Bolt
1	STK-G-01610	1	1412 - Pull Through Wireway - Gasket
3	STK-Q-08100	1	M5 Nylon Insert Lock Nut
3	STK-A-33033	4	5412 ESMCH Hinge
2	1412SS4036BC-P	0	Box Connector - Part
1	1412SS4036C-P	0	1412 SS4036 Cover Part
1	1412SS4036B-P		1412 SS4036 Body Part
Qty	Part Number	Rev.	Description

Parts List

No.	Revisions	Date	By/Par

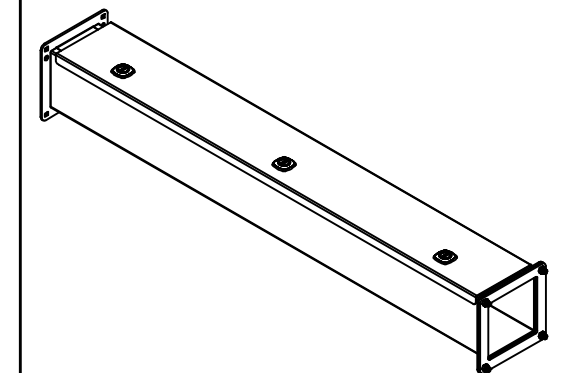

Tél: (450) 979-4373
Fax: (450) 979-4626
www.exmweb.com

Flatness
Aplatissement
Max 3.0mm

Projection

Customer Client		Date
Drawn By / Dessiné Par: Hunter		Date: 12-Oct-22
Material / Matière: 16 Ga Cold Rolled A1008 CS Type B (1.4mm)		
Color / Couleur: Asa-61 Grey	Finish / Fini: Smooth	
Description: 1412 SS4036 Assembly		Detail Rev.
Part Number / Numéro Pièce: 1412SS4036		Rev. 0

APPROVED FOR PRODUCTION
APPROUVÉ POUR PRODUCTION

SIGNATURE: _____
NAME / NOM: _____
DATE: _____

Please visit: www.boxcadexm.com

This drawing is confidential and must not be reproduced or used without the consent of EXM

Ce dessin est confidentiel et ne doit pas être reproduit ou utilisé sans le consentement de EXM

No.	Revisions	Date	By/Par

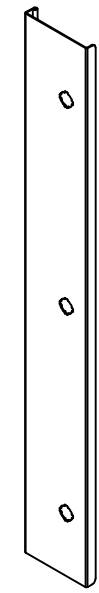
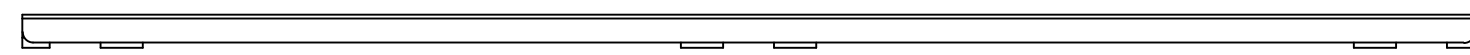
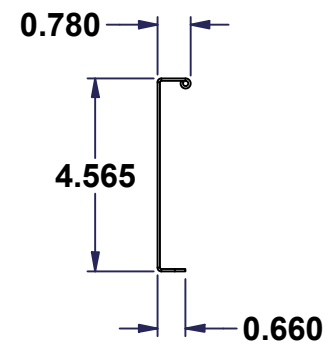
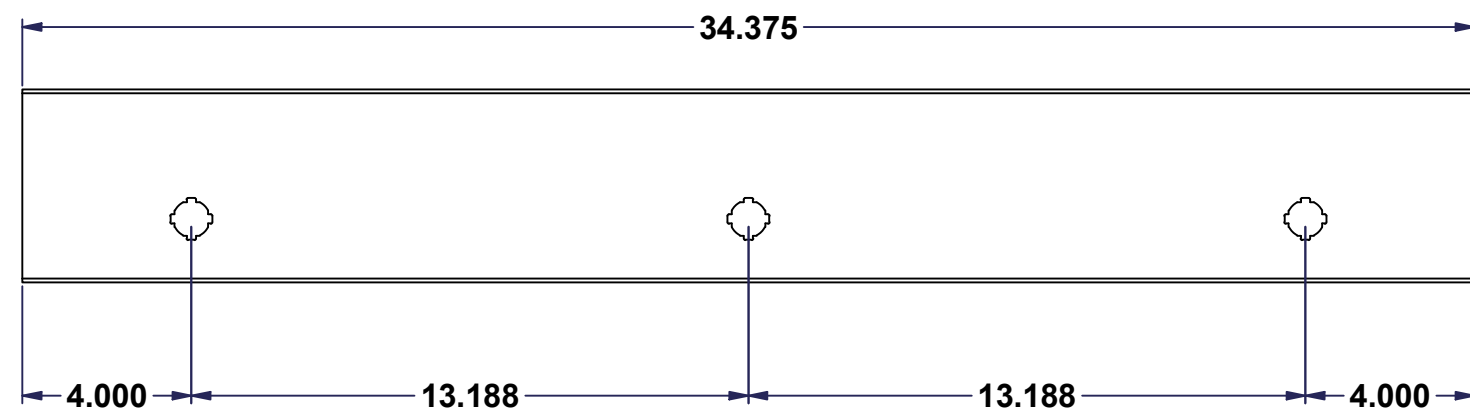
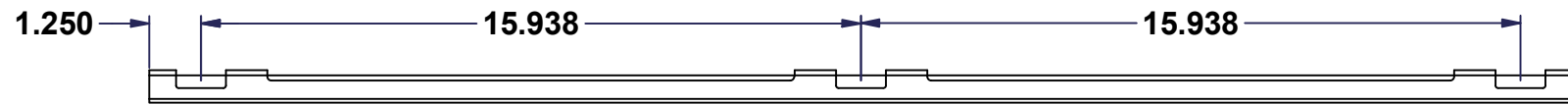

Isometric View



Tél: (450) 979-4373
 Fax: (450) 979-4626
www.exmweb.com

Flatness
 Aplatissement
 Max 3.0mm
 Projection

Customer Client	Date
Drawn By / Dessiné Par: Hunter	Date: 12-Oct-22
Material / Matière: 16 Ga Cold Rolled A1008 CS Type B (1.4mm)	

Color / Couleur: Asa-61 Grey	Finish / Fini: Smooth
------------------------------	-----------------------

Description: 1412 SS4036 Cover Part	Detail Rev.
-------------------------------------	-------------

Part Number / Numéro Pièce: 1412SS4036C-P	Rev. 0	2 / 4
---	--------	-------

APPROVED FOR PRODUCTION
APPROUVÉ POUR PRODUCTION
 SIGNATURE: _____
 NAME / NOM: _____
 DATE: _____
 Please visit: www.boxcadexm.com

This drawing is confidential and must not be reproduced or used without the consent of EXM

Ce dessin est confidentiel et ne doit pas être reproduit ou utilisé sans le consentement de EXM

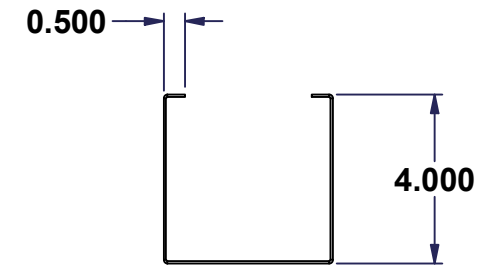
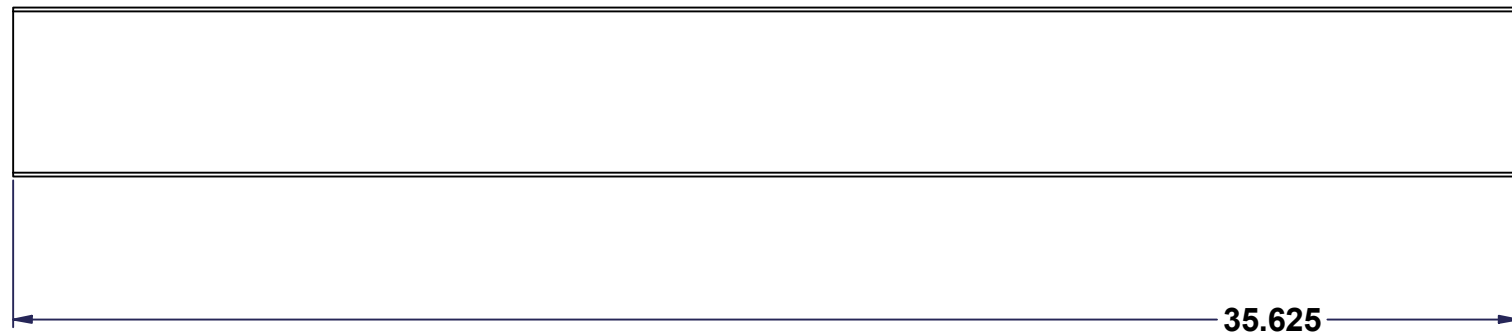
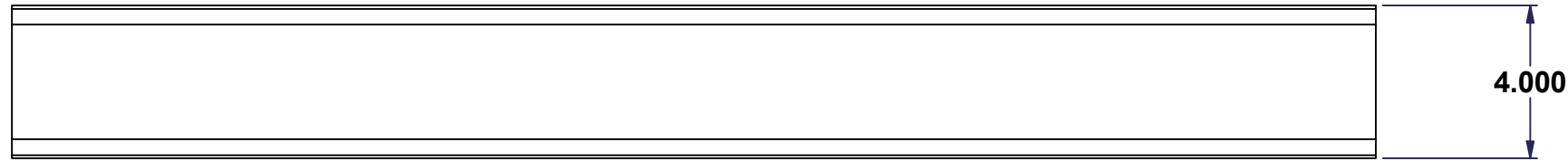
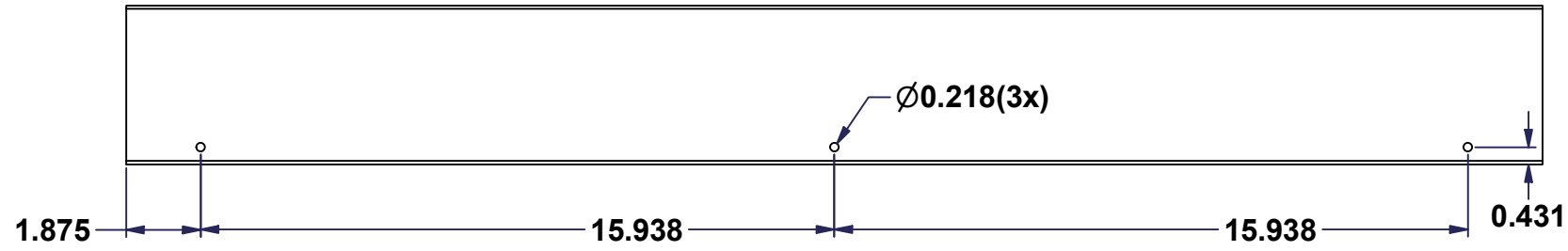

No.	Revisions	Date	By/Par

Isometric View

Tél: (450) 979-4373 Fax: (450) 979-4626 www.exmweb.com		Flatness Aplatissement	Max 3.0mm
		Projection	
Customer Client	Date		
Drawn By Dessiné Par	Hunter	Date	12-Oct-22
Material Matière	16 Ga Cold Rolled A1008 CS Type B (1.4mm)		
Color Couleur	Asa-61 Grey	Finish Fini	Smooth
Description		Detail Rev.	
1412 SS4036 Body Part			
Part Number Numéro Pièce	1412SS4036B-P	Rev.	3 0
			4

APPROVED FOR PRODUCTION
APPROUVÉ POUR PRODUCTION
 SIGNATURE: _____
 NAME / NOM: _____
 DATE: _____
 Please visit: www.boxcadexm.com

This drawing is confidential and must not be reproduced or used without the consent of EXM

Ce dessin est confidentiel et ne doit pas être reproduit ou utilisé sans le consentement de EXM

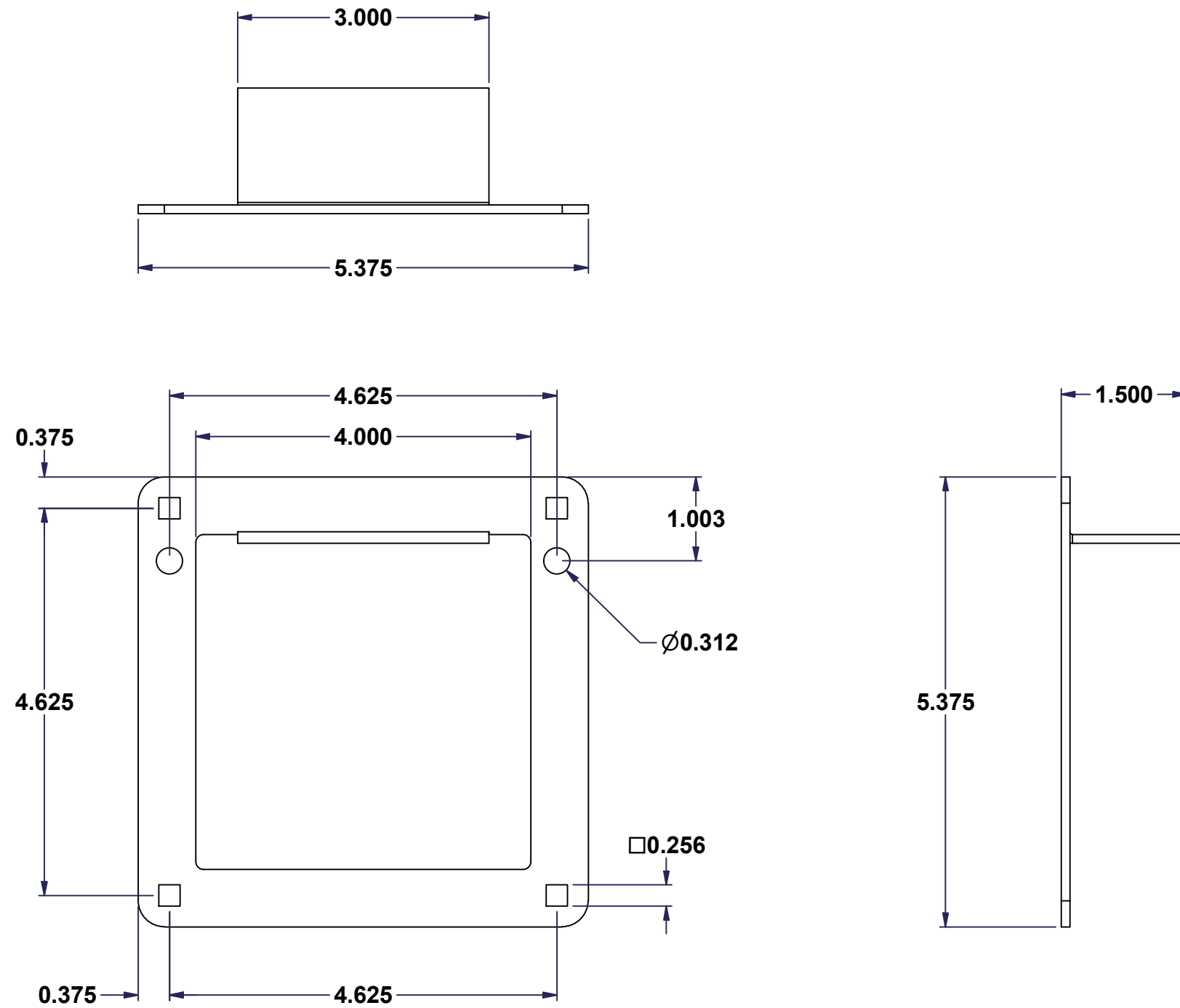

No.	Revisions	Date	By/Par

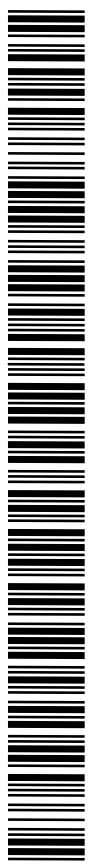
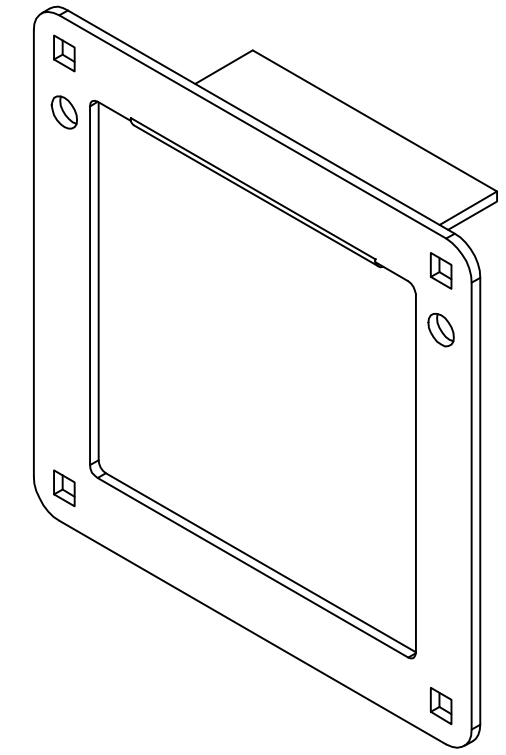

Isometric View

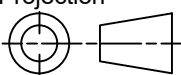
 Tél: (450) 979-4373 Fax: (450) 979-4626 www.exmweb.com		Flatness Aplatissement Max 3.0mm Projection 
Customer Client	Date	
Drawn By / Dessiné Par: Hunter	Date: 12-Oct-22	
Material / Matière: 12 Ga Cold Rolled A1008 CS Type B (2.5mm)		
Color / Couleur: Asa-61 Grey	Finish / Fini: Smooth	
Description: Box Connector - Part		Detail Rev.
Part Number / Numéro Pièce: 1412SS4036BC-P	Rev. 0	4 / 4

APPROVED FOR PRODUCTION
APPROUVÉ POUR PRODUCTION
 SIGNATURE: _____
 NAME / NOM: _____
 DATE: _____
 Please visit: www.boxcadexm.com