

This drawing is confidential and must not be reproduced or used without the consent of EXM

Ce dessin est confidentiel et ne doit pas être reproduit ou utilisé sans le consentement de EXM

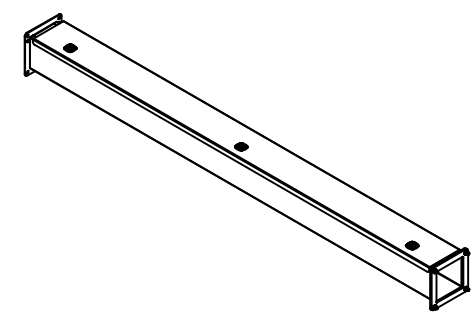

Isometric View

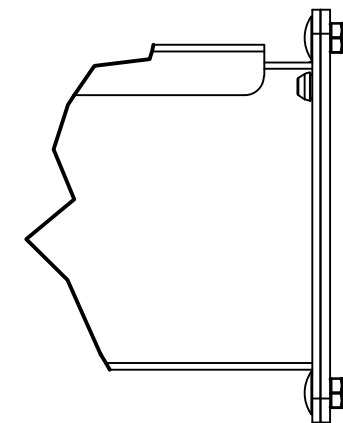
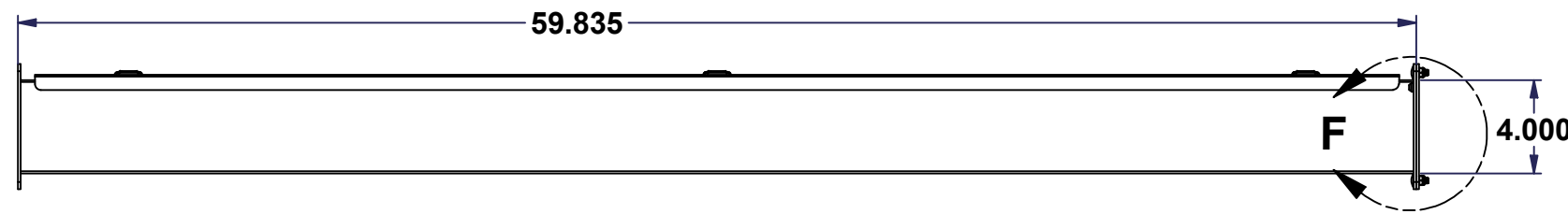
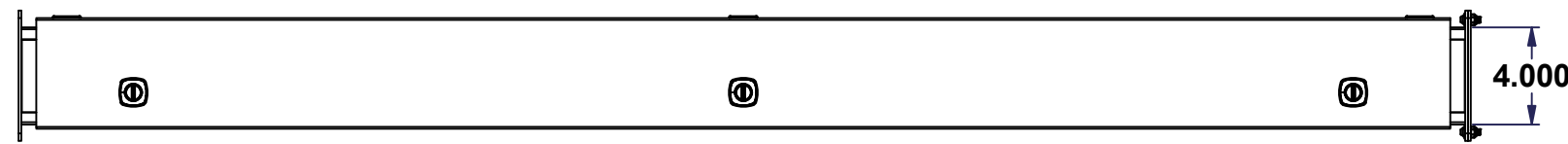
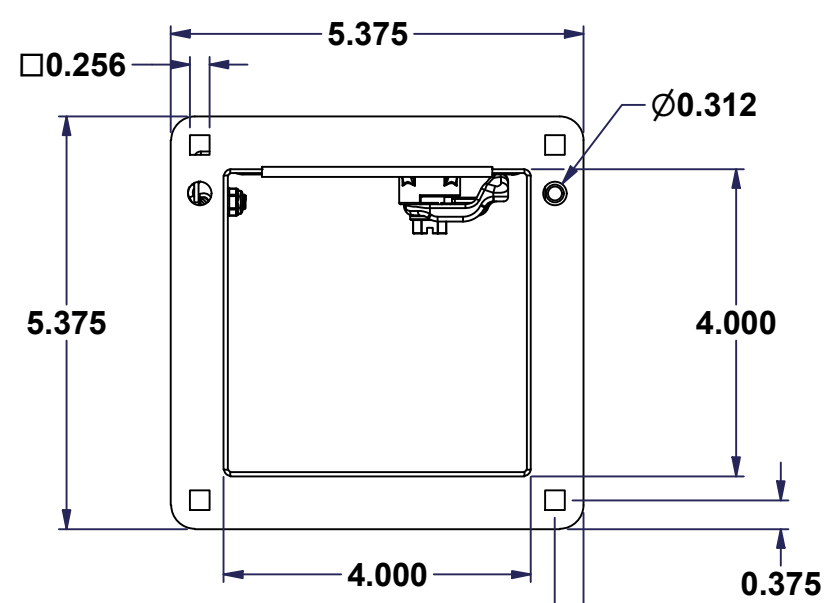
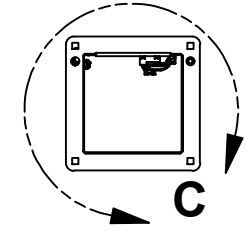

DETAIL C

DETAIL F

No.	Revisions	Date	By/Par



Tél: (450) 979-4373 Fax: (450) 979-4626 www.exmweb.com		Flatness Aplatissement Max 3.0mm Projection
Customer Client	Date	
Drawn By / Dessiné Par: Hunter	Date: 12-Oct-22	
Material / Matière: 16 Ga Cold Rolled A1008 CS Type B (1.4mm)	Color / Couleur: Asa-61 Grey	
Description: 1412 SS4060 Assembly		Finish / Fini: Smooth
Part Number / Numéro Pièce: 1412SS4060	Rev.:	1
		4

1	1412SS4060G	0	1412 SS - Cover Gasket
3	STK-K-12520	4	1/4 Turn for 1500 CH Throughs - Lock Assembly
4	STK-Q-07225	0	M6 Stainless Steel Nylon Insert Lock Nut
4	STK-Q-00266	0	M6 x 16mm Stainless Steel 316 Carriage Bolt
1	STK-G-01610	1	1412 - Pull Through Wireway - Gasket
3	STK-Q-08100	1	M5 Nylon Insert Lock Nut
3	STK-A-33033	4	5412 ESMCH Hinge
2	1412SS4060BC-P	0	Box Connector - Part
1	1412SS4060C-P	0	1412 SS4060 Cover Part
1	1412SS4060B-P	0	1412 SS4060 Body Part
Qty	Part Number	Rev.	Description

Parts List

APPROVED FOR PRODUCTION
APPROUVÉ POUR PRODUCTION
 SIGNATURE: _____
 NAME / NOM: _____
 DATE: _____
 Please visit: www.boxcadexm.com

This drawing is confidential and must not be reproduced or used without the consent of EXM

Ce dessin est confidentiel et ne doit pas être reproduit ou utilisé sans le consentement de EXM

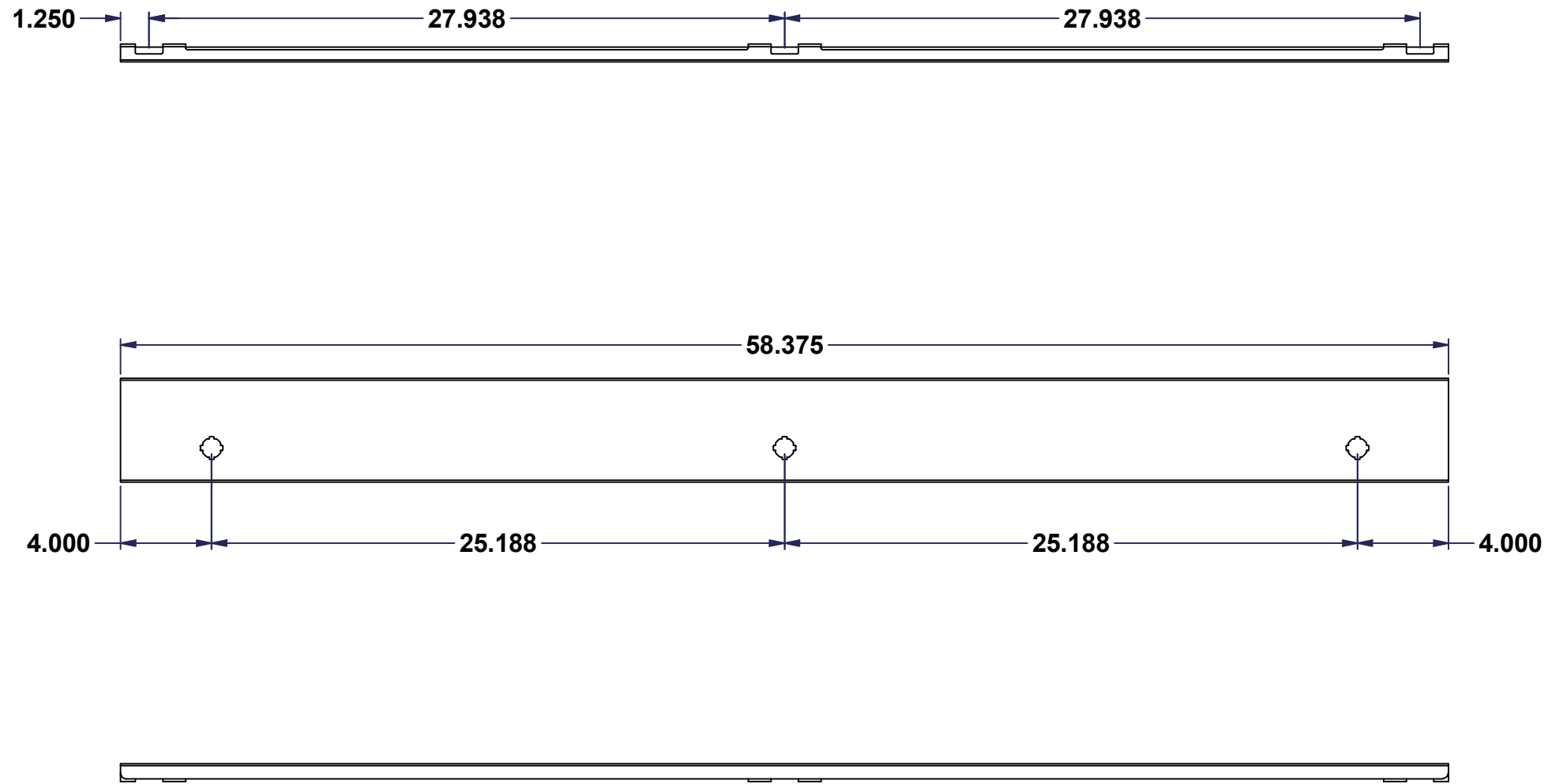

No.	Revisions	Date	By/Par

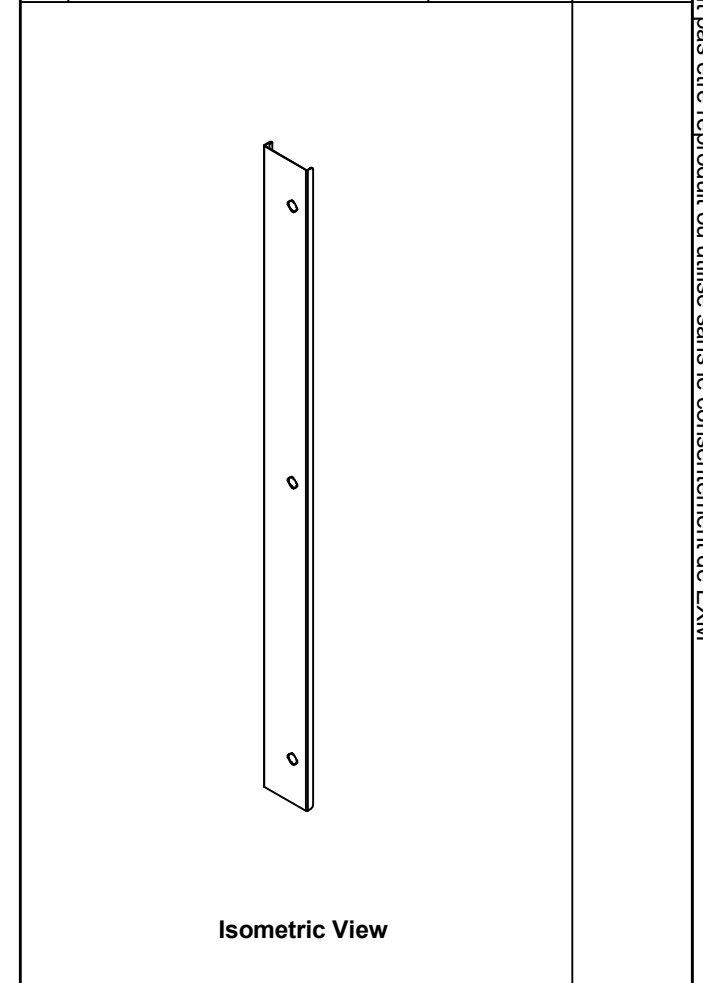

 Tél: (450) 979-4373 Fax: (450) 979-4626 www.exmweb.com		Flatness Aplatissement
		Max 3.0mm
Customer Client		Date
Drawn By Dessiné Par Hunter		Date 12-Oct-22
Material Matière 16 Ga Cold Rolled A1008 CS Type B (1.4mm)		
Color Couleur	Asa-61 Grey	Finish Fini Smooth
Description 1412 SS4060 Cover Part		Detail Rev.
Part Number Numéro Pièce	1412SS4060C-P	Rev. 0
		2 4

APPROVED FOR PRODUCTION
APPROUVÉ POUR PRODUCTION
 SIGNATURE: _____
 NAME / NOM: _____
 DATE: _____
 Please visit: www.boxcadexm.com

This drawing is confidential and must not be reproduced or used without the consent of EXM

Ce dessin est confidentiel et ne doit pas être reproduit ou utilisé sans le consentement de EXM

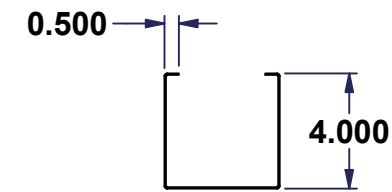
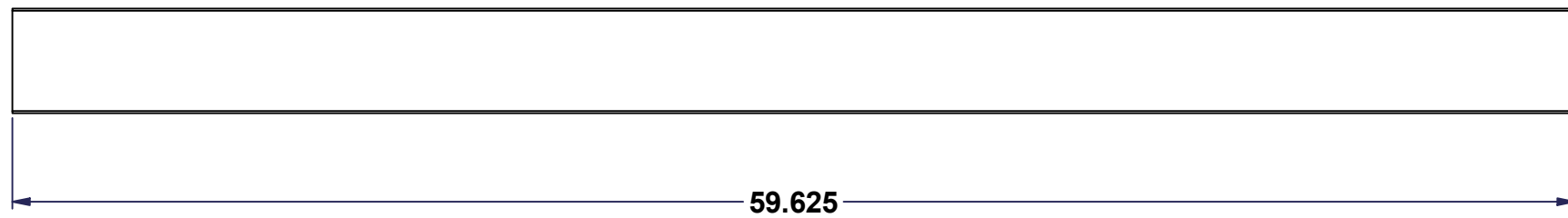
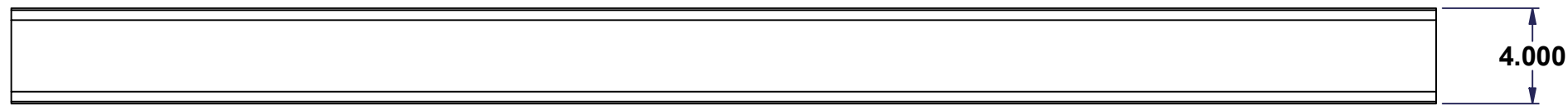
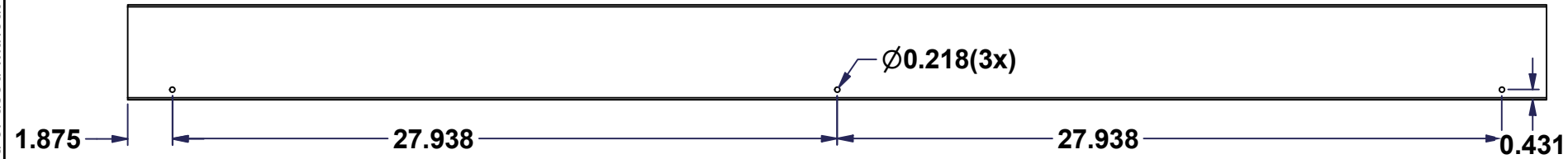

No.	Revisions	Date	By/Par

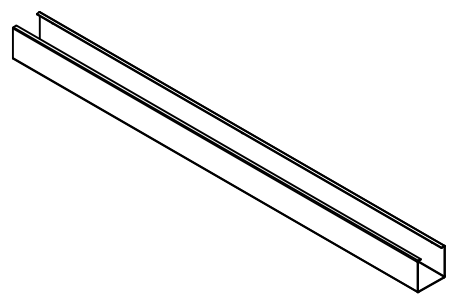

Isometric View



 Tél: (450) 979-4373 Fax: (450) 979-4626 www.exmweb.com		Flatness Aplatissement	
		Max 3.0mm	
Customer Client		Date	
Drawn By Dessiné Par: Hunter		Date: 12-Oct-22	
Material Matière: 16 Ga Cold Rolled A1008 CS Type B (1.4mm)			
Color Couleur: Asa-61 Grey		Finish Fini: Smooth	
Description 1412 SS4060 Body Part			Detail Rev.
Part Number Numéro Pièce: 1412SS4060B-P		Rev. 0	3/4

APPROVED FOR PRODUCTION
APPROUVÉ POUR PRODUCTION
 SIGNATURE: _____
 NAME / NOM: _____
 DATE: _____
 Please visit: www.boxcadexm.com

This drawing is confidential and must not be reproduced or used without the consent of EXM

Ce dessin est confidentiel et ne doit pas être reproduit ou utilisé sans le consentement de EXM

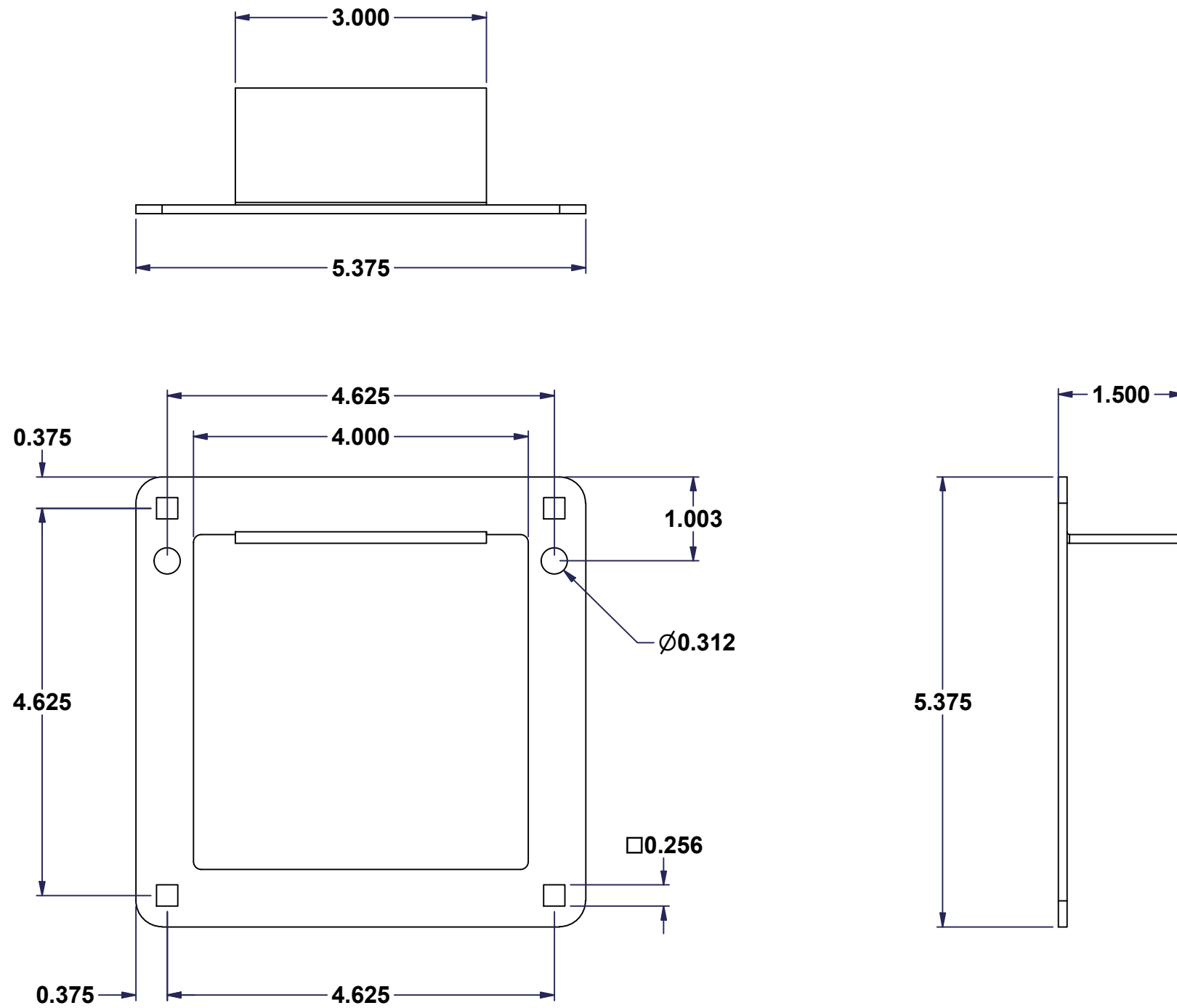

No.	Revisions	Date	By/Par

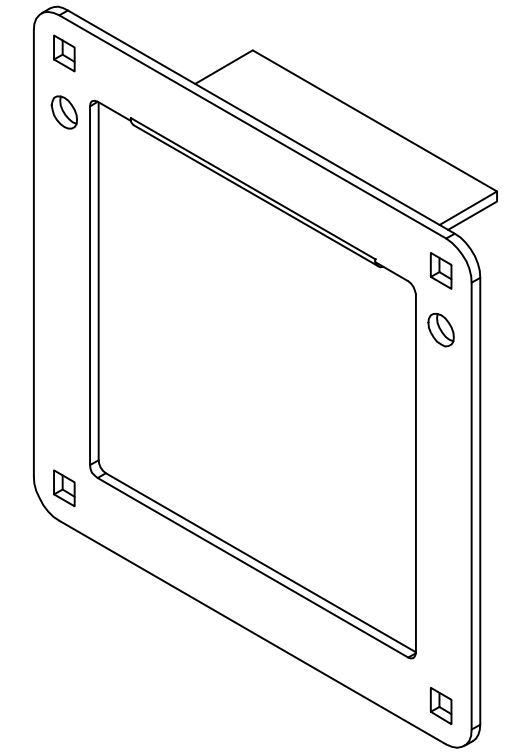

Isometric View

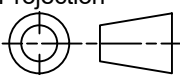

 Tél: (450) 979-4373 Fax: (450) 979-4626 www.exmweb.com		Flatness Aplatissement Max 3.0mm Projection 
Customer Client	Date	
Drawn By / Dessiné Par: Hunter	Date: 12-Oct-22	
Material / Matière: 12 Ga Cold Rolled A1008 CS Type B (2.5mm)		
Color / Couleur: Asa-61 Grey	Finish / Fini: Smooth	
Description: Box Connector - Part	Detail Rev.	
Part Number / Numéro Pièce: 1412SS4060BC-P	Rev. 0	4 / 4

APPROVED FOR PRODUCTION
APPROUVÉ POUR PRODUCTION
 SIGNATURE: _____
 NAME / NOM: _____
 DATE: _____
 Please visit: www.boxcadexm.com