

This drawing is confidential and must not be reproduced or used without the consent of EXM

Ce dessin est confidentiel et ne doit pas être reproduit ou utilisé sans le consentement de EXM

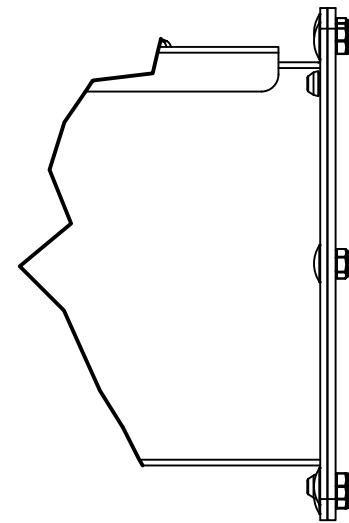

DETAIL F

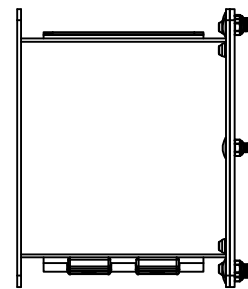
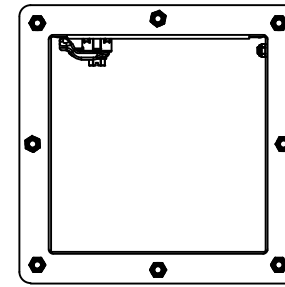
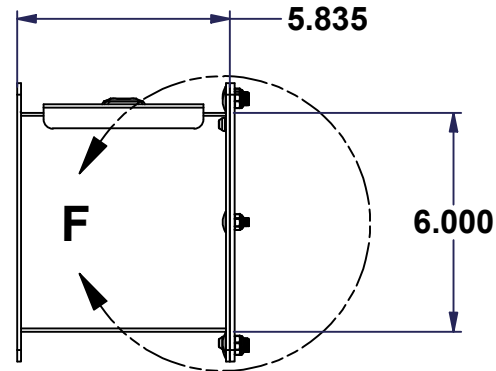
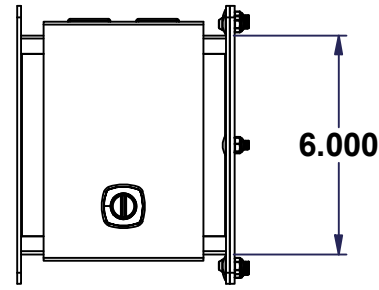
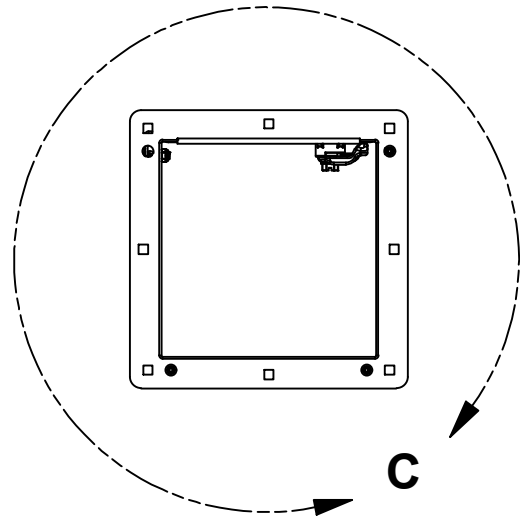
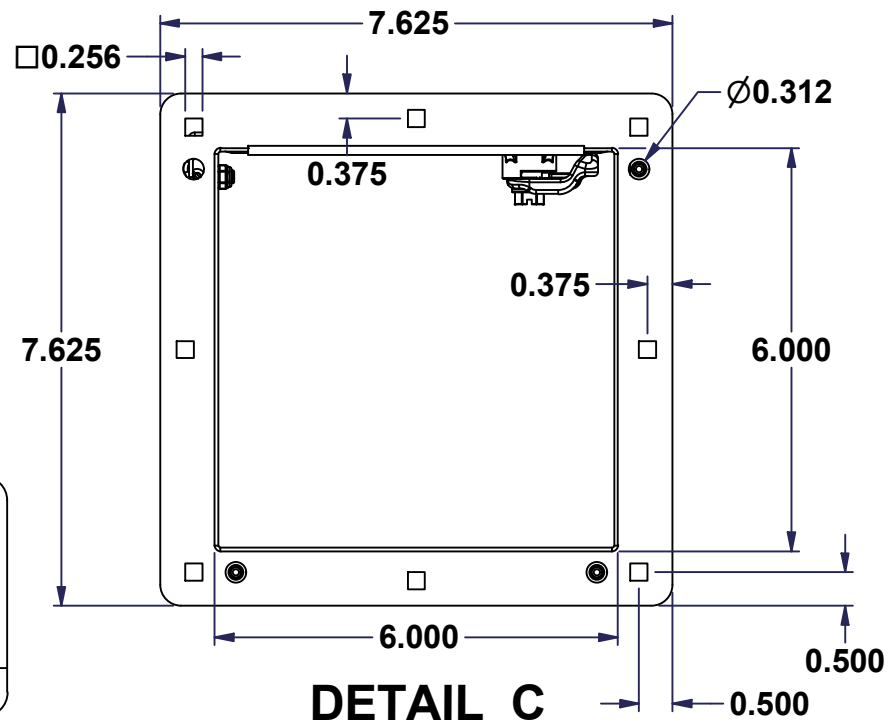

DETAIL C

No.	Revisions	Date	By/Par

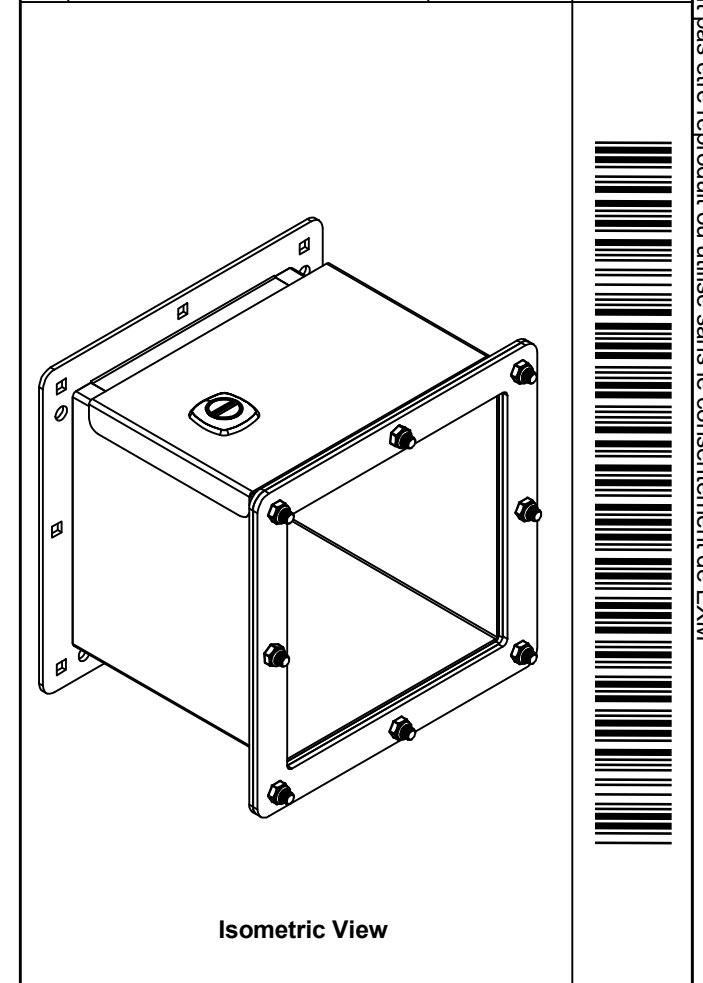

Isometric View

EXM
exm

Tél: (450) 979-4373
Fax: (450) 979-4626
www.exmweb.com

Flatness
Aplatissement
Max 3.0mm

Projection

1	1412SS6006G	0	1412 SS - Cover Gasket
1	STK-K-12520	4	1/4 Turn for 1500 CH Throughs - Lock Assembly
8	STK-Q-07225	0	M6 Stainless Steel Nylon Insert Lock Nut
8	STK-Q-00266	0	M6 x 16mm Stainless Steel 316 Carriage Bolt
1	STK-G-01620	1	1412 - Pull Through Wireway - Gasket
2	STK-Q-08100	1	M5 Nylon Insert Lock Nut
2	STK-A-33033	4	5412 ESMCH Hinge
2	1412SS6006BC-P	0	Box Connector - Part
1	1412SS6006C-P	0	1412 SS6006 Cover Part
1	1412SS6006B-P		1412 SS6006 Body Part
Qty	Part Number	Rev.	Description

Parts List

Customer Client	Date
Drawn By Dessiné Par Hunter	Date 12-Oct-22
Material Matière 16 Ga Cold Rolled A1008 CS Type B (1.4mm)	
Color Couleur Asa-61 Grey	Finish Fini Smooth
Description 1412 SS6006 Assembly	Detail Rev.
Part Number Numéro Pièce 1412SS6006	Rev. 0

APPROVED FOR PRODUCTION
APPROUVÉ POUR PRODUCTION

SIGNATURE: _____
NAME / NOM: _____
DATE: _____

Please visit: www.boxcadexm.com

This drawing is confidential and must not be reproduced or used without the consent of EXM

Ce dessin est confidentiel et ne doit pas être reproduit ou utilisé sans le consentement de EXM

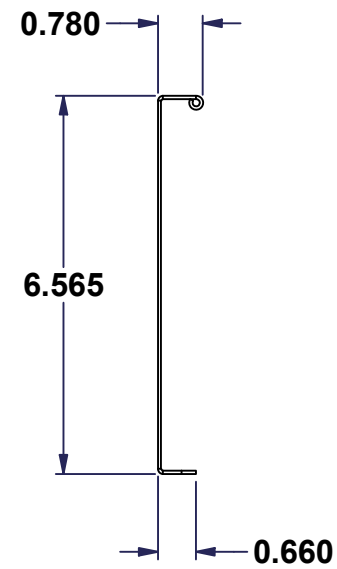
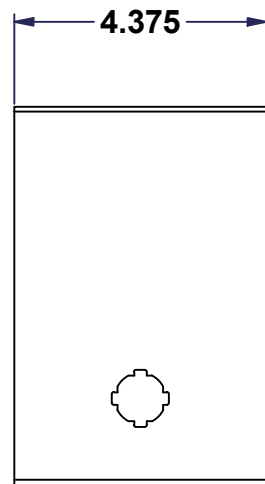
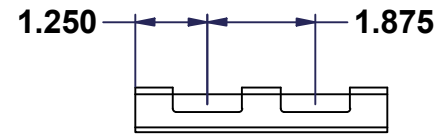

No.	Revisions	Date	By/Par

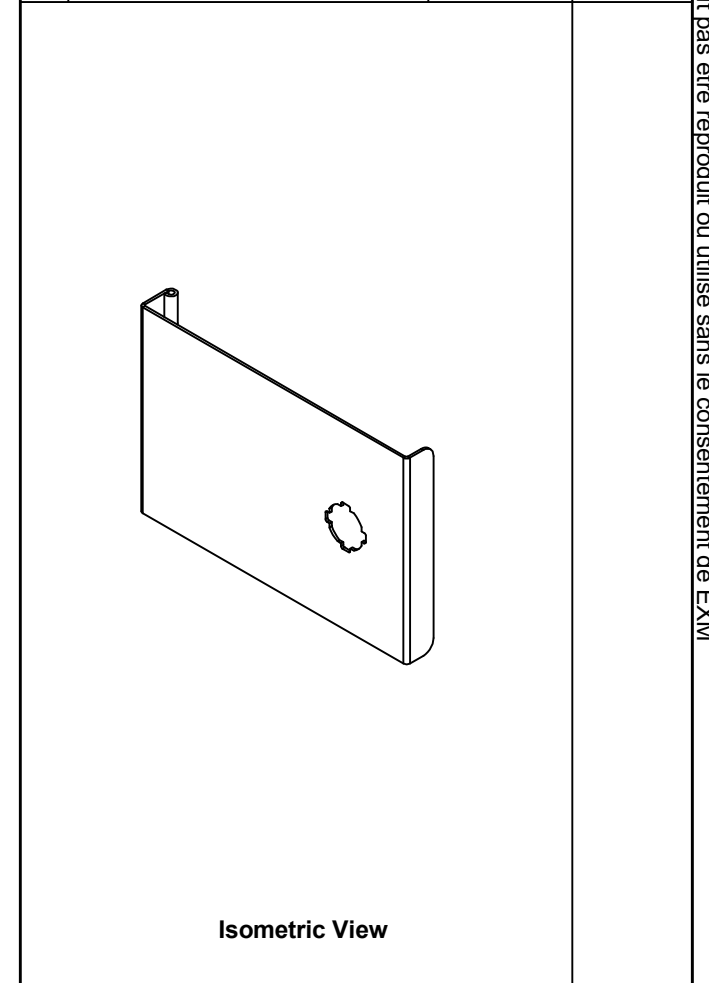

EXM
exm

Tél: (450) 979-4373
Fax: (450) 979-4626
www.exmweb.com

Flatness
Aplatissement
Max 3.0mm

Projection

Customer Client	Date
Drawn By / Dessiné Par: Hunter	Date: 12-Oct-22
Material / Matière: 16 Ga Cold Rolled A1008 CS Type B (1.4mm)	

Color / Couleur: Asa-61 Grey	Finish / Fini: Smooth
------------------------------	-----------------------

Description: 1412 SS6006 Cover Part	Detail Rev.
-------------------------------------	-------------

Part Number / Numéro Pièce: 1412SS6006C-P	Rev. 0	2 / 4
--	---------------	-------

APPROVED FOR PRODUCTION
APPROUVÉ POUR PRODUCTION

SIGNATURE: _____
NAME / NOM: _____
DATE: _____

Please visit: www.boxcadexm.com

This drawing is confidential and must not be reproduced or used without the consent of EXM

Ce dessin est confidentiel et ne doit pas être reproduit ou utilisé sans le consentement de EXM

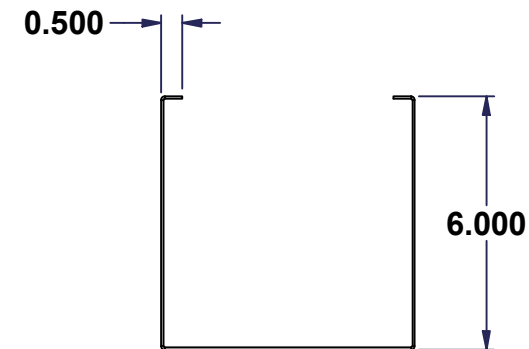
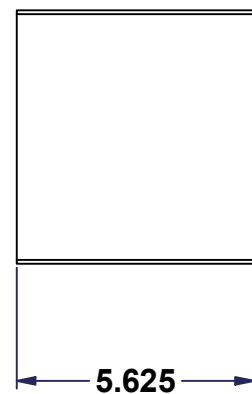
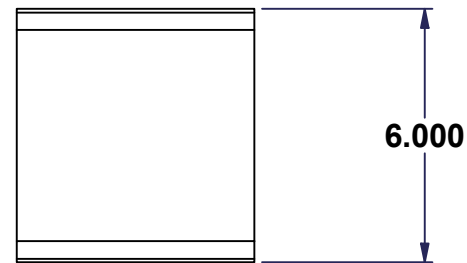
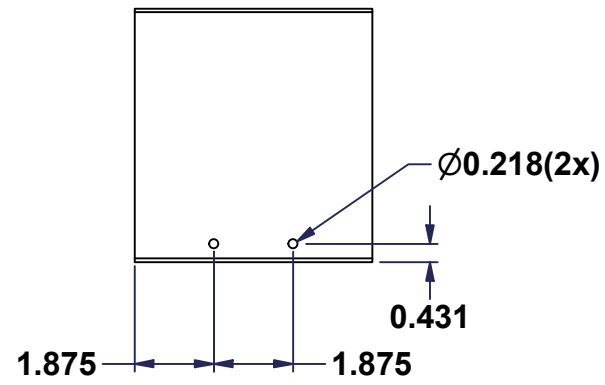

No.	Revisions	Date	By/Par

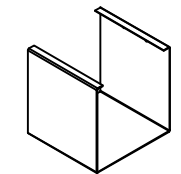

Isometric View



Tél: (450) 979-4373
 Fax: (450) 979-4626
www.exmweb.com

Flatness
Aplatissement

Max 3.0mm

Projection

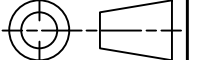

Customer Client	Date
Drawn By / Dessiné Par: Hunter	Date: 12-Oct-22
Material / Matière: 16 Ga Cold Rolled A1008 CS Type B (1.4mm)	

Color / Couleur: Asa-61 Grey	Finish / Fini: Smooth
------------------------------	-----------------------

Description: 1412 SS6006 Body Part	Detail Rev.
------------------------------------	-------------

Part Number / Numéro Pièce: 1412SS6006B-P	Rev. 0	3 / 4
---	--------	-------

APPROVED FOR PRODUCTION
APPROUVÉ POUR PRODUCTION
 SIGNATURE: _____
 NAME / NOM: _____
 DATE: _____
 Please visit: www.boxcadexm.com

This drawing is confidential and must not be reproduced or used without the consent of EXM

Ce dessin est confidentiel et ne doit pas être reproduit ou utilisé sans le consentement de EXM

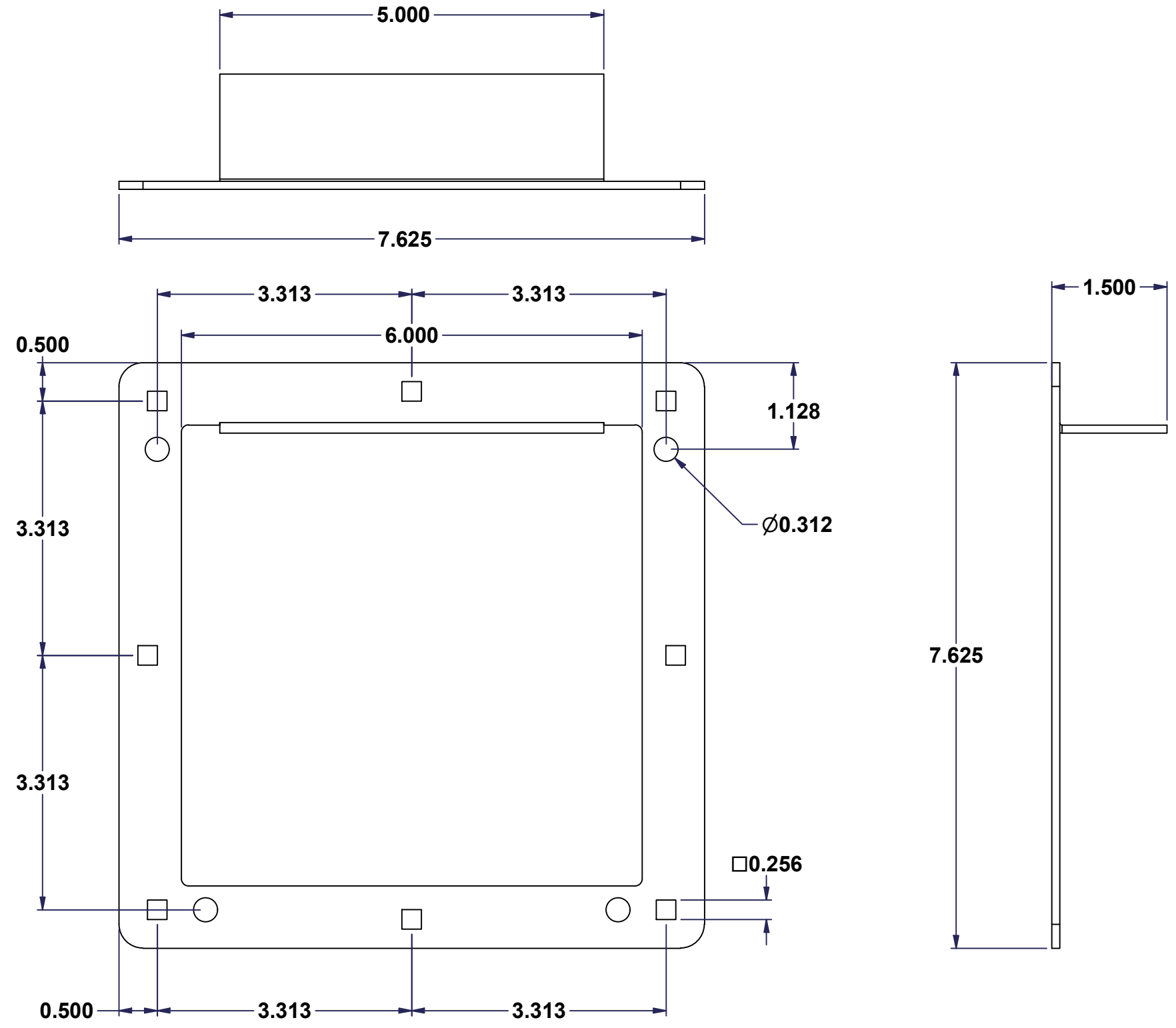

No.	Revisions	Date	By/Par

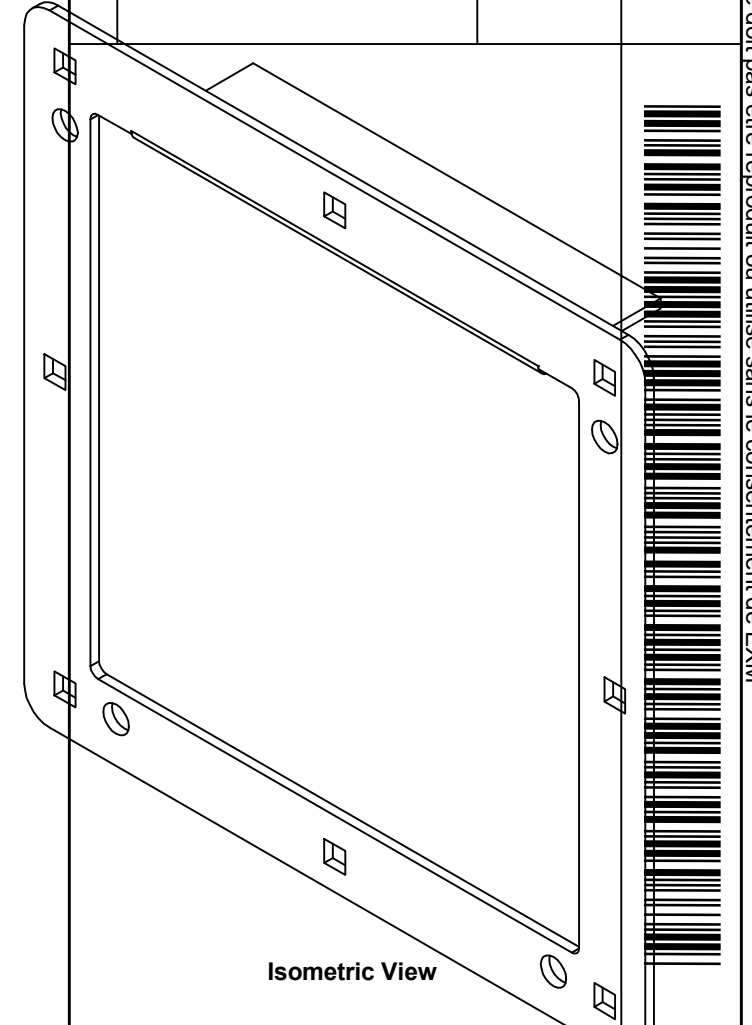

Tél: (450) 979-4373
 Fax: (450) 979-4626
www.exmweb.com

Flatness / Aplatissement
 Max 3.0mm
 Projection

Customer Client	Date
Drawn By / Dessiné Par: Hunter	Date: 12-Oct-22
Material / Matière: 12 Ga Cold Rolled A1008 CS Type B (2.5mm)	
Color / Couleur: Asa-61 Grey	Finish / Fini: Smooth
Description: Box Connector - Part	Detail Rev.
Part Number / Numéro Pièce: 1412SS6006BC-P	Rev. 0

APPROVED FOR PRODUCTION
APPROUVÉ POUR PRODUCTION
 SIGNATURE: _____
 NAME / NOM: _____
 DATE: _____
 Please visit: www.boxcadexm.com

4 / 4