

This drawing is confidential and must not be reproduced or used without the consent of EXM

Ce dessin est confidentiel et ne doit pas être reproduit ou utilisé sans le consentement de EXM

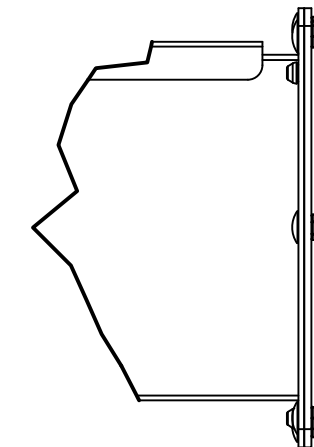

Isometric View

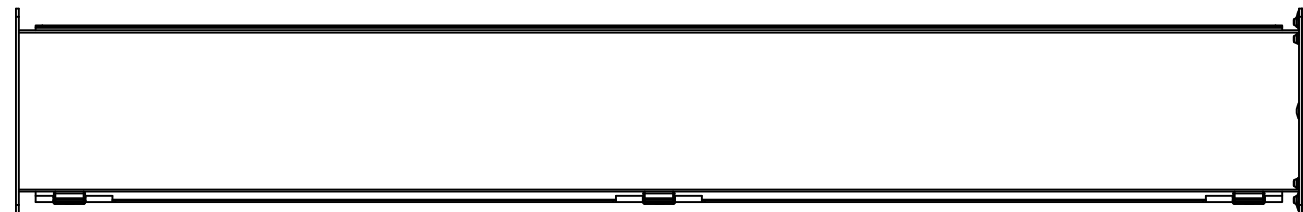
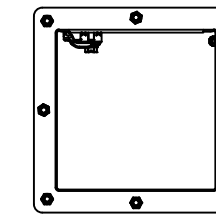
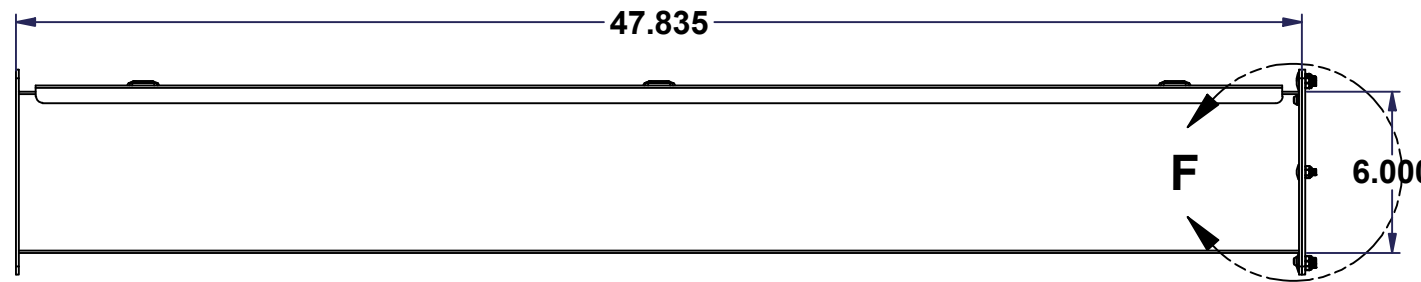
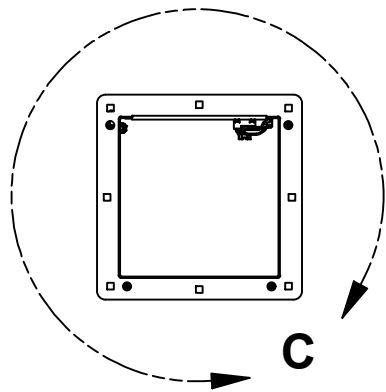
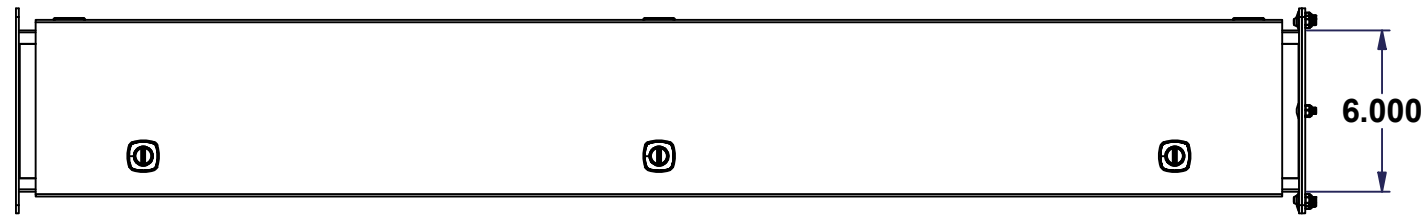
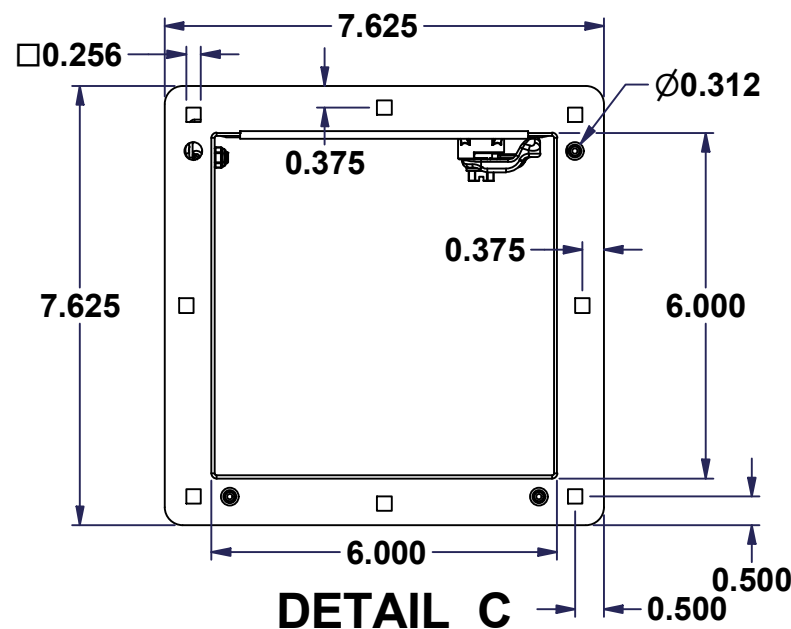

DETAIL C

DETAIL F



No.	Revisions	Date	By/Par

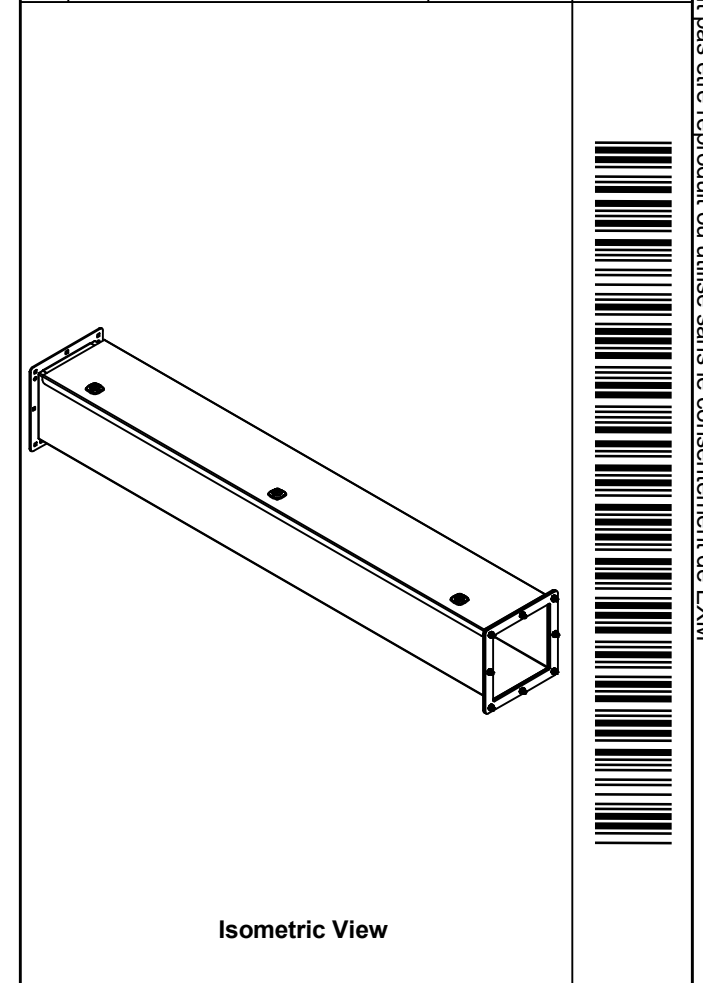

**EXM**  
exm

Tél: (450) 979-4373  
Fax: (450) 979-4626  
[www.exmweb.com](http://www.exmweb.com)

Flatness  
Aplatissement  
Max 3.0mm  
Projection

Customer Client	Date
Drawn By / Dessiné Par: Hunter	Date: 12-Oct-22
Material / Matière: 16 Ga Cold Rolled A1008 CS Type B (1.4mm)	

Color / Couleur: Asa-61 Grey	Finish / Fini: Smooth
Description: 1412 SS6048 Assembly	Detail Rev.
Part Number / Numéro Pièce: <b>1412SS6048</b>	Rev. 0

1	1412SS6048G	0	1412 SS - Cover Gasket
3	STK-K-12520	4	1/4 Turn for 1500 CH Throughs - Lock Assembly
8	STK-Q-07225	0	M6 Stainless Steel Nylon Insert Lock Nut
8	STK-Q-00266	0	M6 x 16mm Stainless Steel 316 Carriage Bolt
1	STK-G-01620	1	1412 - Pull Through Wireway - Gasket
2	STK-Q-08100	1	M5 Nylon Insert Lock Nut
3	STK-A-33033	4	5412 ESMCH Hinge
2	1412SS6048BC-P	0	Box Connector - Part
1	1412SS6048C-P	0	1412 SS6048 Cover Part
1	1412SS6048B-P		1412 SS6048 Body Part
Qty	Part Number	Rev.	Description

Parts List

**APPROVED FOR PRODUCTION**  
**APPROUVÉ POUR PRODUCTION**

SIGNATURE: \_\_\_\_\_  
NAME / NOM: \_\_\_\_\_  
DATE: \_\_\_\_\_

Please visit: [www.boxcadexm.com](http://www.boxcadexm.com)

This drawing is confidential and must not be reproduced or used without the consent of EXM

Ce dessin est confidentiel et ne doit pas être reproduit ou utilisé sans le consentement de EXM

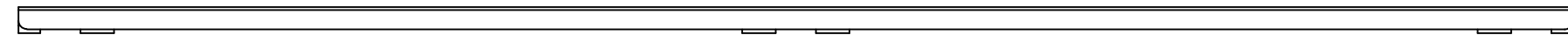
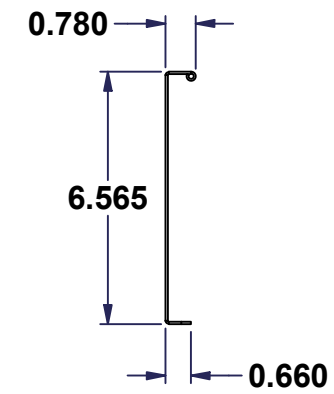
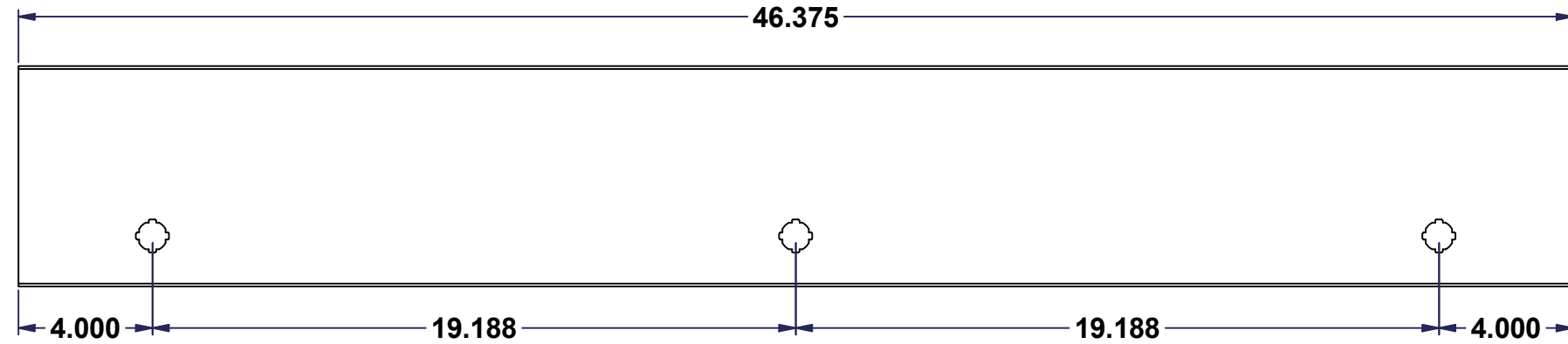

No.	Revisions	Date	By/Par

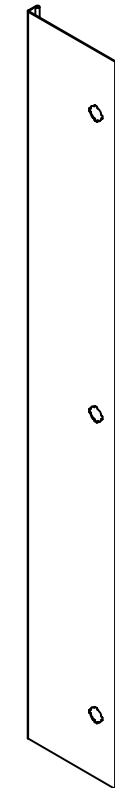

Isometric View



Tél: (450) 979-4373  
 Fax: (450) 979-4626  
[www.exmweb.com](http://www.exmweb.com)

Flatness  
Aplatissement

Max 3.0mm

Projection

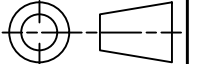

Customer Client	Date
Drawn By Dessiné Par Hunter	Date 12-Oct-22
Material Matière 16 Ga Cold Rolled A1008 CS Type B (1.4mm)	

Color Couleur Asa-61 Grey	Finish Fini Smooth
------------------------------	-----------------------

Description 1412 SS6048 Cover Part	Detail Rev.
---------------------------------------	-------------

Part Number Numéro Pièce <b>1412SS6048C-P</b>	Rev. <b>0</b>	2 4
---	------------------	--------

**APPROVED FOR PRODUCTION  
 APPROUVÉ POUR PRODUCTION**

SIGNATURE: \_\_\_\_\_  
 NAME / NOM: \_\_\_\_\_  
 DATE: \_\_\_\_\_

Please visit: [www.boxcadexm.com](http://www.boxcadexm.com)

This drawing is confidential and must not be reproduced or used without the consent of EXM

Ce dessin est confidentiel et ne doit pas être reproduit ou utilisé sans le consentement de EXM

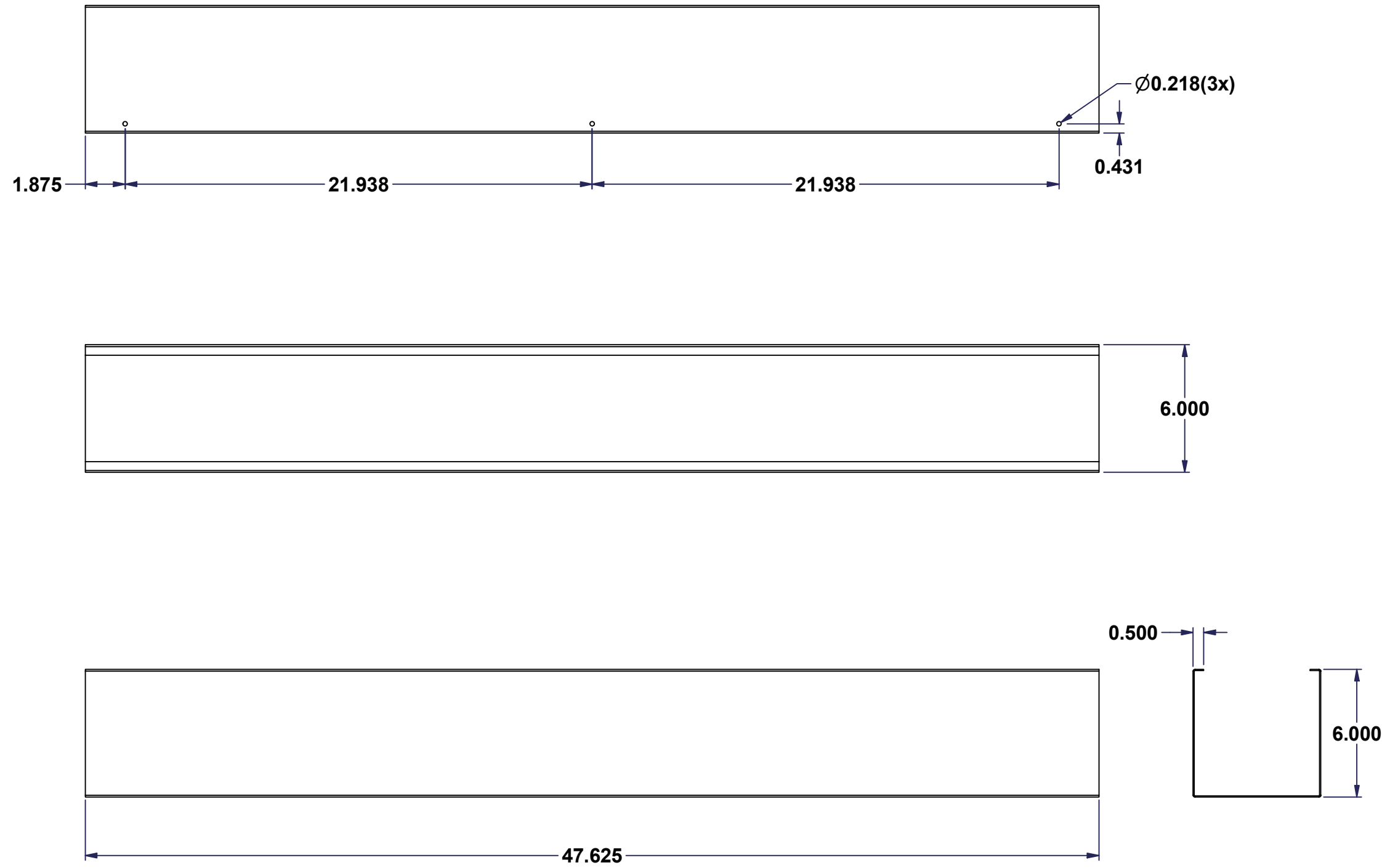

No.	Revisions	Date	By/Par

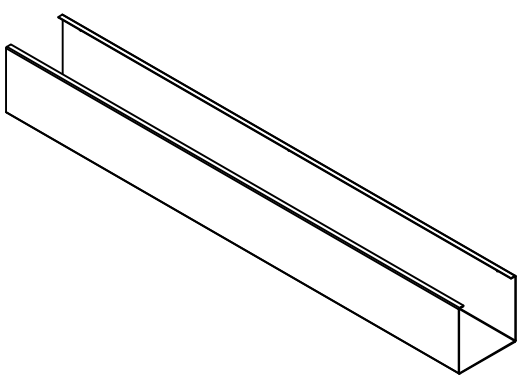

**Isometric View**

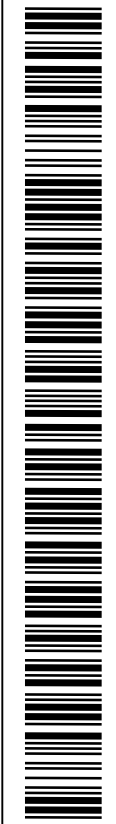

 Tél: (450) 979-4373 Fax: (450) 979-4626 <a href="http://www.exmweb.com">www.exmweb.com</a>		Flatness Aplatissement	
		Max 3.0mm	
Customer Client		Date	
Drawn By Dessiné Par Hunter		Date 12-Oct-22	
Material Matière 16 Ga Cold Rolled A1008 CS Type B (1.4mm)			
Color Couleur Asa-61 Grey		Finish Fini Smooth	
Description 1412 SS6048 Body Part			Detail Rev.
Part Number Numéro Pièce <b>1412SS6048B-P</b>		Rev. <b>0</b>	3 4

**APPROVED FOR PRODUCTION**  
**APPROUVÉ POUR PRODUCTION**  
 SIGNATURE: \_\_\_\_\_  
 NAME / NOM: \_\_\_\_\_  
 DATE: \_\_\_\_\_  
 Please visit: [www.boxcadexm.com](http://www.boxcadexm.com)

This drawing is confidential and must not be reproduced or used without the consent of EXM

Ce dessin est confidentiel et ne doit pas être reproduit ou utilisé sans le consentement de EXM

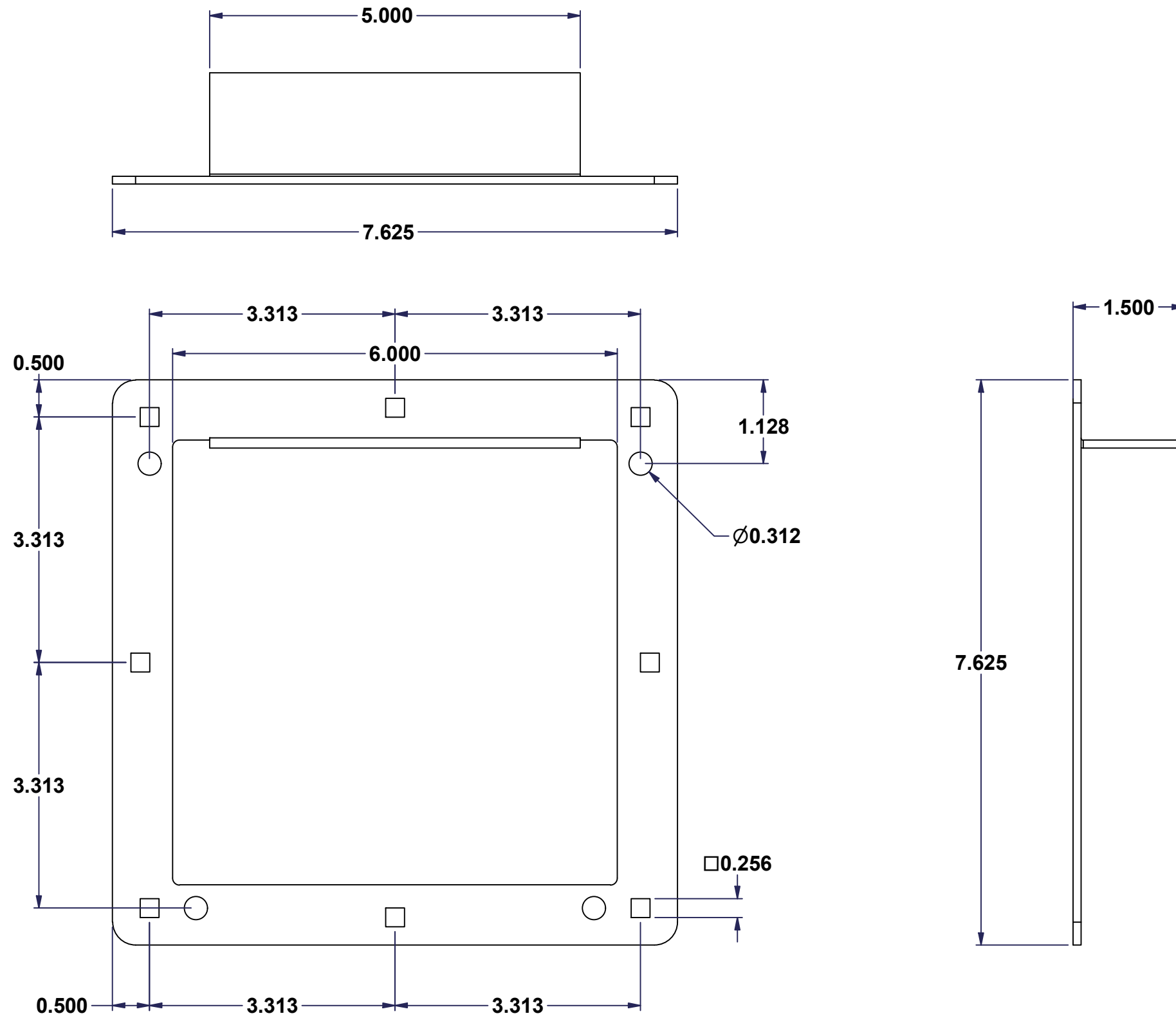

No.	Revisions	Date	By/Par

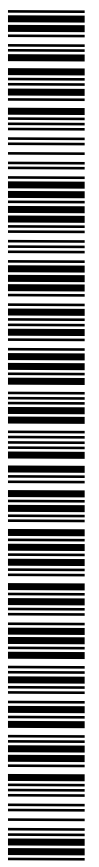
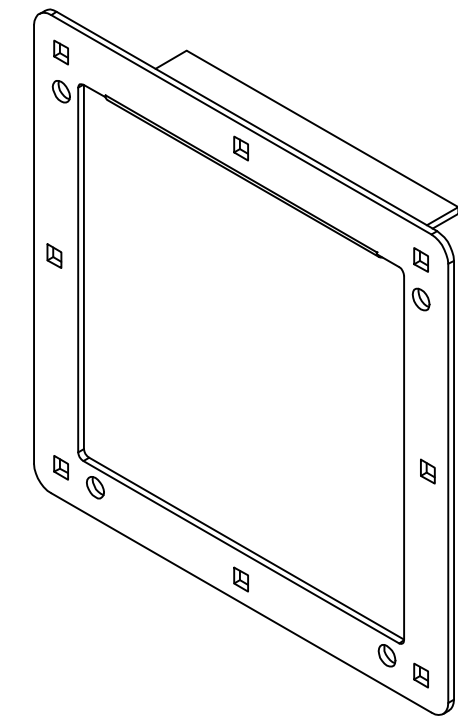

Isometric View

	Flatness Aplatissement Max 3.0mm
	Projection 
Customer Client	Date
Drawn By Dessiné Par: Hunter	Date: 12-Oct-22
Material Matière: 12 Ga Cold Rolled A1008 CS Type B (2.5mm)	
Color Couleur: Asa-61 Grey	Finish Fini: Smooth
Description: Box Connector - Part	
Part Number Numéro Pièce: 1412SS6048BC-P	Rev. 4 0

**APPROVED FOR PRODUCTION**  
**APPROUVÉ POUR PRODUCTION**  
 SIGNATURE: \_\_\_\_\_  
 NAME / NOM: \_\_\_\_\_  
 DATE: \_\_\_\_\_  
 Please visit: [www.boxcadexm.com](http://www.boxcadexm.com)