

This drawing is confidential and must not be reproduced or used without the consent of EXM

Ce dessin est confidentiel et ne doit pas être reproduit ou utilisé sans le consentement de EXM

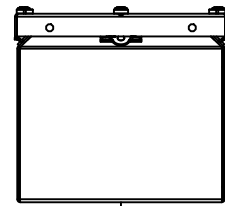

TOP

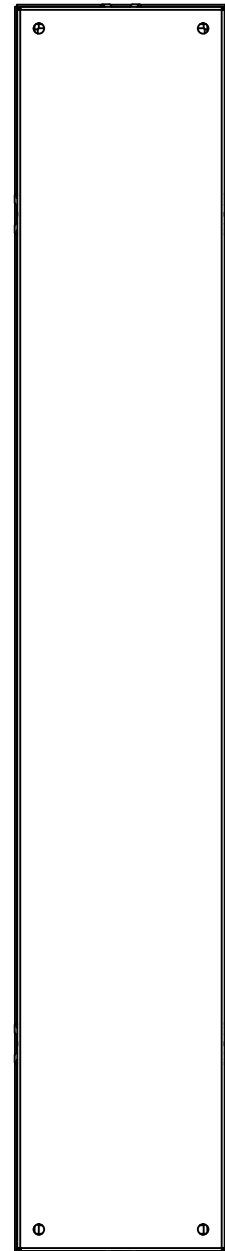

BACK

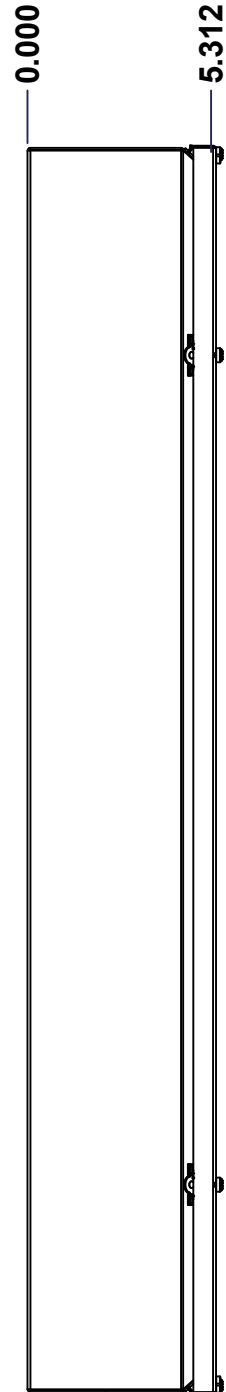
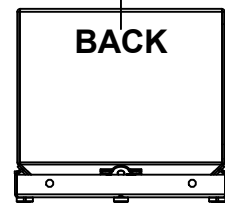

LEFT

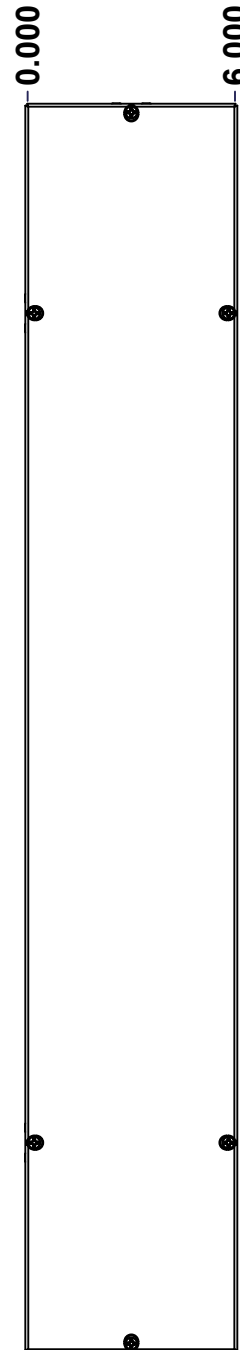

FRONT

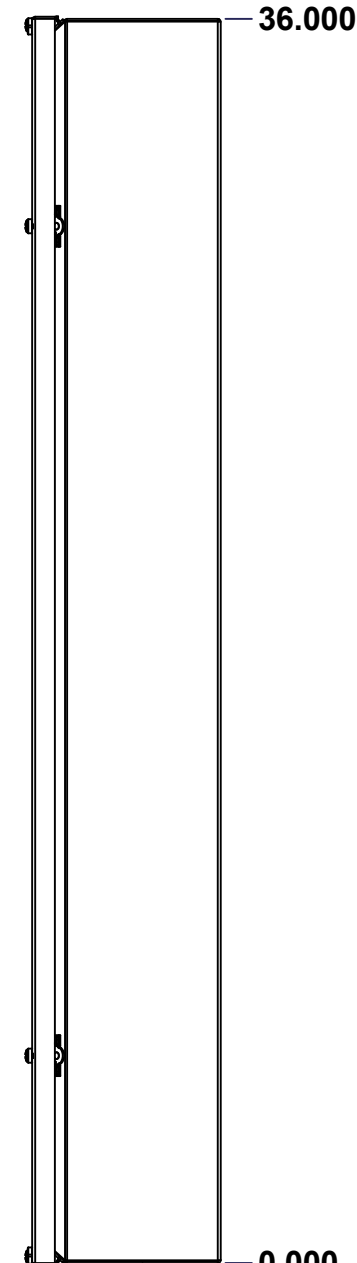

RIGHT

APPROVED FOR PRODUCTION
APPROUVÉ POUR PRODUCTION
 SIGNATURE: _____
 NAME / NOM: _____
 DATE: _____
 Please visit: www.boxcadexm.com

No.	Revisions	Date	By/Par

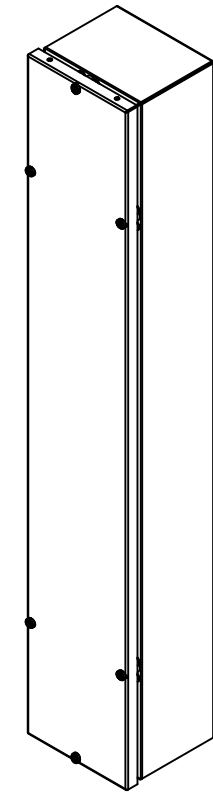

Isometric View

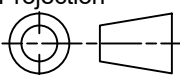

 Tél: (450) 979-4373 Fax: (450) 979-4626 www.exmweb.com		Flatness Aplatissement Max 3.0mm Projection 
Customer Client	Date	
Drawn By Dessiné Par	BoxCad: ArthurC	Date 20-Oct-20
Material Matière	16 Ga H.R.P. & O. (1.4mm)	
Color Couleur	Asa-61 Grey	Finish Fini Smooth
Description	Detail Rev.	
1412T373 Assembly		
Part Number Numéro Pièce	Rev.	1 5
1412T373		0

This drawing is confidential and must not be reproduced or used without the consent of EXM

Ce dessin est confidentiel et ne doit pas être reproduit ou utilisé sans le consentement de EXM

NOTE	
ITEM	DESCRIPTION
1	NEMA/EEMAC 3R-4-12 Enclosure
2	C/W Standard ground standoffs on box and cover
3	W/O Standard door stiffener
4	C/W Inner panel
5	C/W Inner panel mounting standoffs

APPROVED FOR PRODUCTION
APPROUVÉ POUR PRODUCTION
 SIGNATURE: _____
 NAME / NOM: _____
 DATE: _____
 Please visit: www.boxcadexm.com

No.	Revisions	Date	By/Par

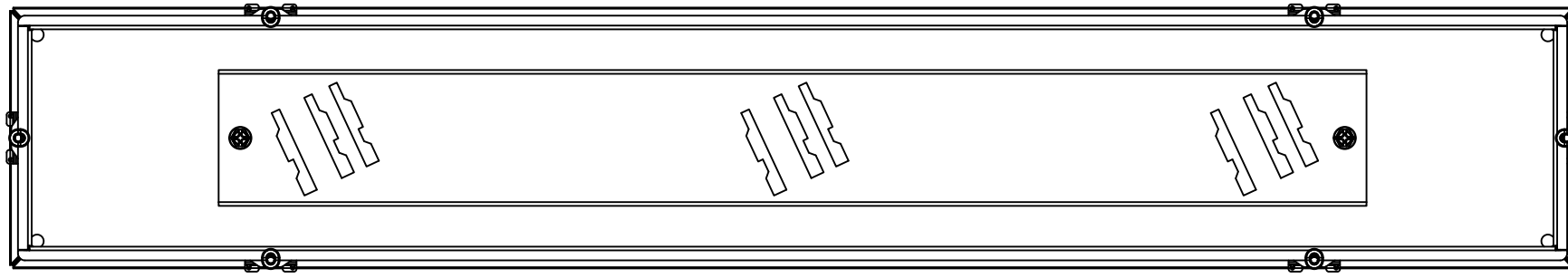

View Without Cover

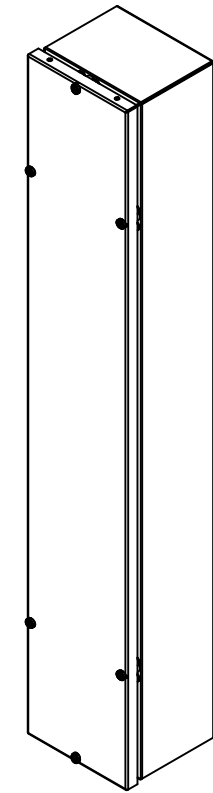

Isometric View

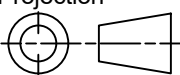

1	STK-K-02910	3	5412 ESCH Accessory Kit
2	STK-Q-03200	0	M6 x 8mm Hexagon/Slot Screw
1	1412T373IP	0	1412T373 Inner Panel
6	STK-Q-03035	4	Stainless Steel 316 Phillips Oval Head Screw M5 x 18.5mm (Pitch 0.8mm)
6	STK-Q-77280	5	5412 ESSC M5 Countersink Insert (Flat Hole)
1	1412T373C	0	1412T373 Cover
1	1412T373B	0	1412T373 Body
Qty	Part Number	Rev.	Description
Parts List			

 Tél: (450) 979-4373 Fax: (450) 979-4626 www.exmweb.com		Flatness Aplatissement Max 3.0mm Projection 
Customer Client	Date	
Drawn By Dessiné Par: BoxCad: ArthurC	Date: 20-Oct-20	
Material Matière: 16 Ga H.R.P. & O. (1.4mm)	Color Couleur: Asa-61 Grey	
Description: 1412T373 Assembly		Finish Fini: Smooth
Part Number Numéro Pièce: 1412T373	Rev. 0	2 / 5

This drawing is confidential and must not be reproduced or used without the consent of EXM

Ce dessin est confidentiel et ne doit pas être reproduit ou utilisé sans le consentement de EXM

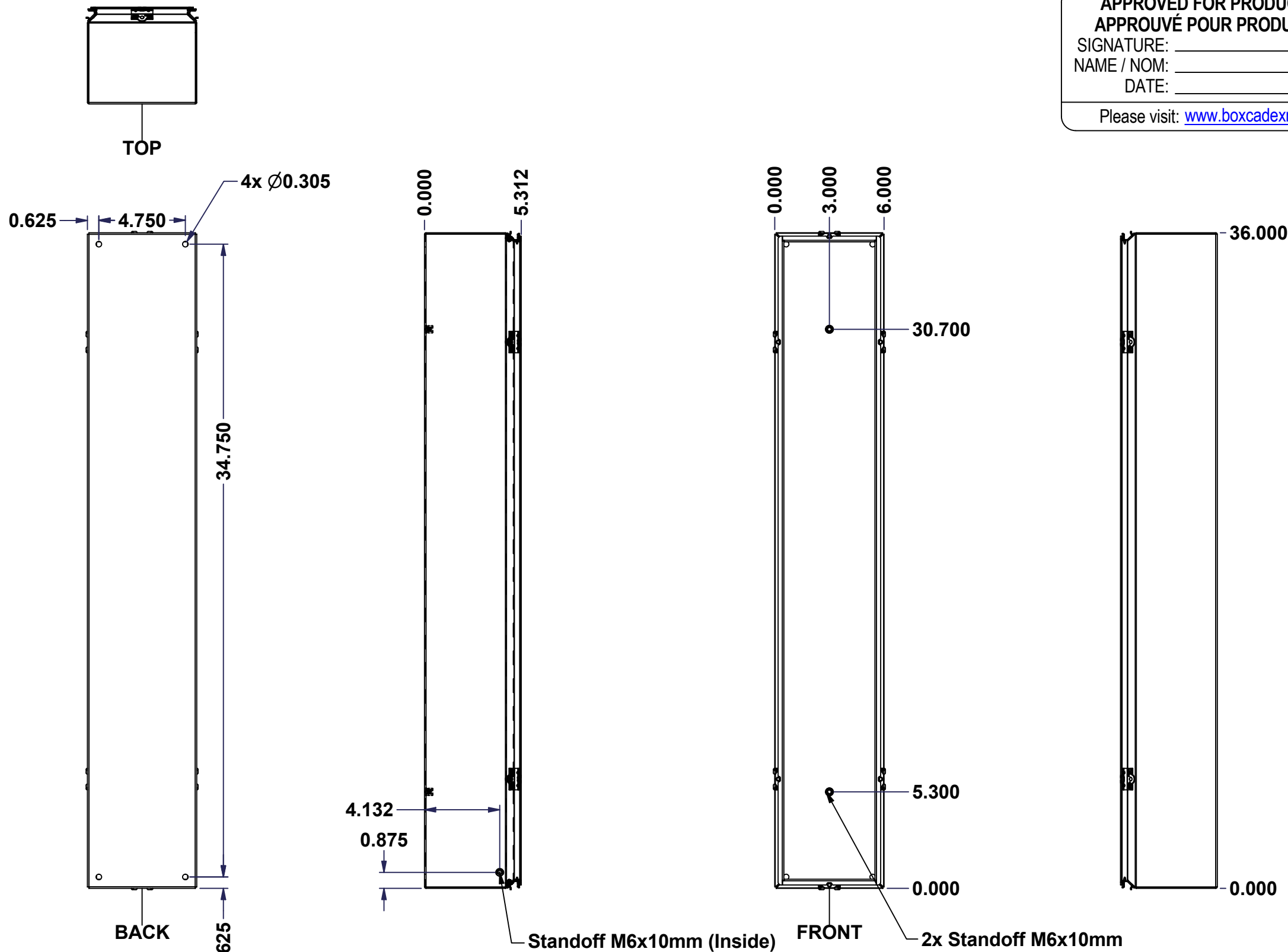

APPROVED FOR PRODUCTION
APPROUVÉ POUR PRODUCTION
 SIGNATURE: _____
 NAME / NOM: _____
 DATE: _____
 Please visit: www.boxcadexm.com

No.	Revisions	Date	By/Par

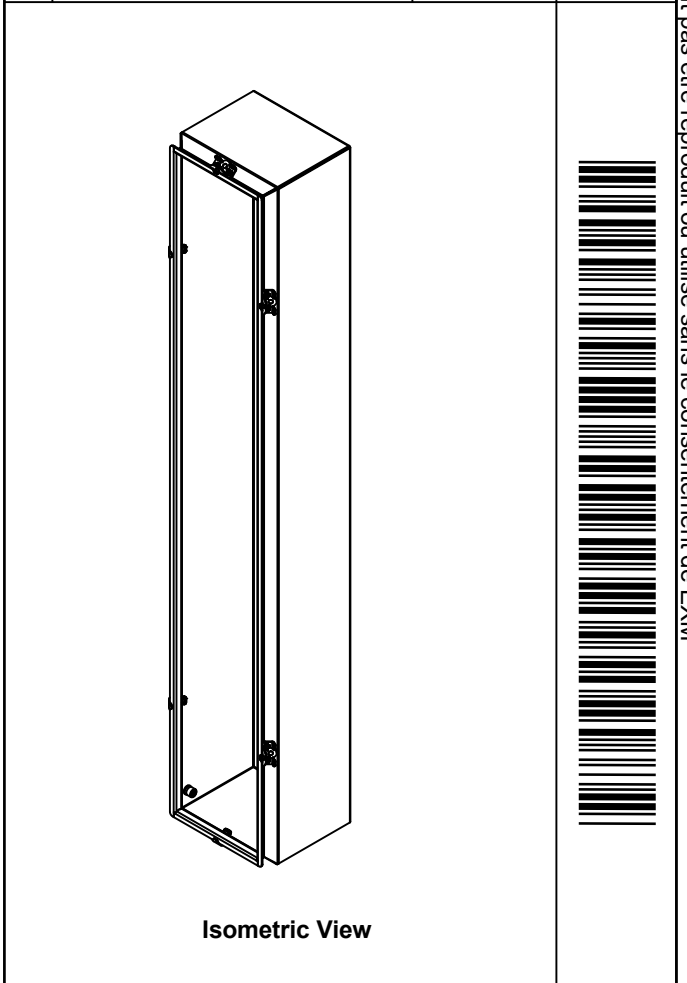

Tél: (450) 979-4373 Fax: (450) 979-4626 www.exmweb.com		Flatness Aplatissement Max 3.0mm Projection
Customer Client	Date	
Drawn By / Dessiné Par: BoxCad: ArthurC	Date	20-Oct-20
Material / Matière: 16 Ga H.R.P. & O. (1.4mm)	Color / Couleur: Asa-61 Grey	Finish / Fini: Smooth
Description: 1412T373 Body	Detail Rev.	
Part Number / Numéro Pièce: 1412T373B	Rev.:	3 / 5

Qty	Part Number	Rev.	Description
1	STK-P-02400S	0	Powder Paint (Asa-61 Grey / Smooth)
3	STANDOFF_M6 x 10mm	5	Standoff M6 x 10mm
1	STK-Q-08100-4	1	M5 Nylon Insert Lock Nut
3	STK-Q-08100-3	1	M5 Nylon Insert Lock Nut
1	STK-Q-08100-2	1	M5 Nylon Insert Lock Nut
1	STK-Q-08100-1	1	M5 Nylon Insert Lock Nut
1	1412T373B-P	0	1412T373 Body Part
6	DEV-STK-Q-70464	2	5412 ESSC & ESSC Stainless Steel Body Catch Assembly
Parts List			

This drawing is confidential and must not be reproduced or used without the consent of EXM

Ce dessin est confidentiel et ne doit pas être reproduit ou utilisé sans le consentement de EXM

APPROVED FOR PRODUCTION
APPROUVÉ POUR PRODUCTION
 SIGNATURE: _____
 NAME / NOM: _____
 DATE: _____
 Please visit: www.boxcadexm.com

No.	Revisions	Date	By/Par

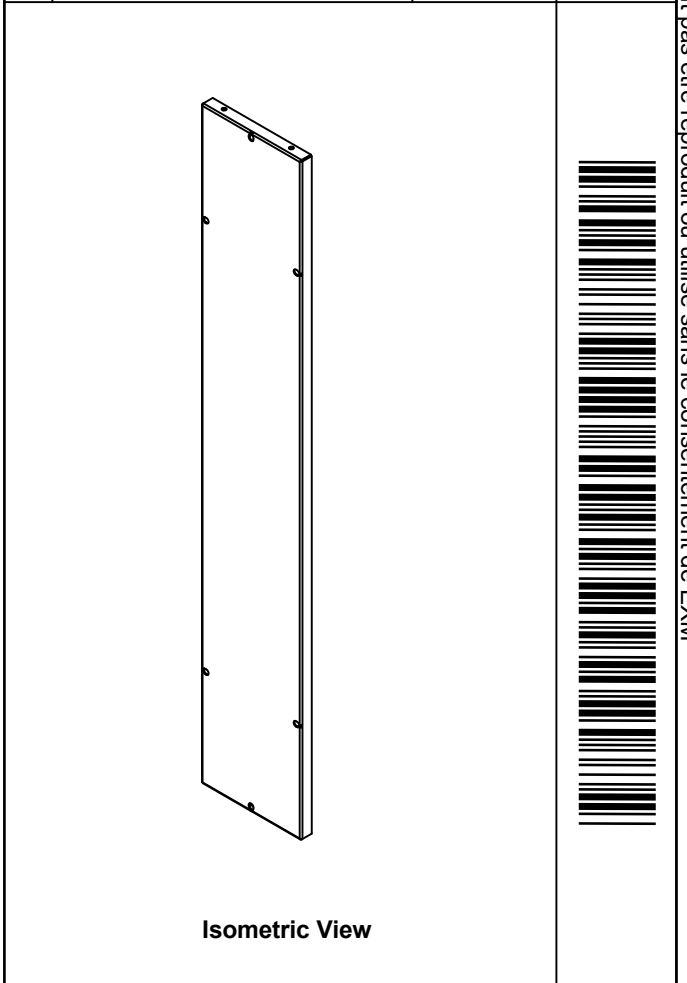
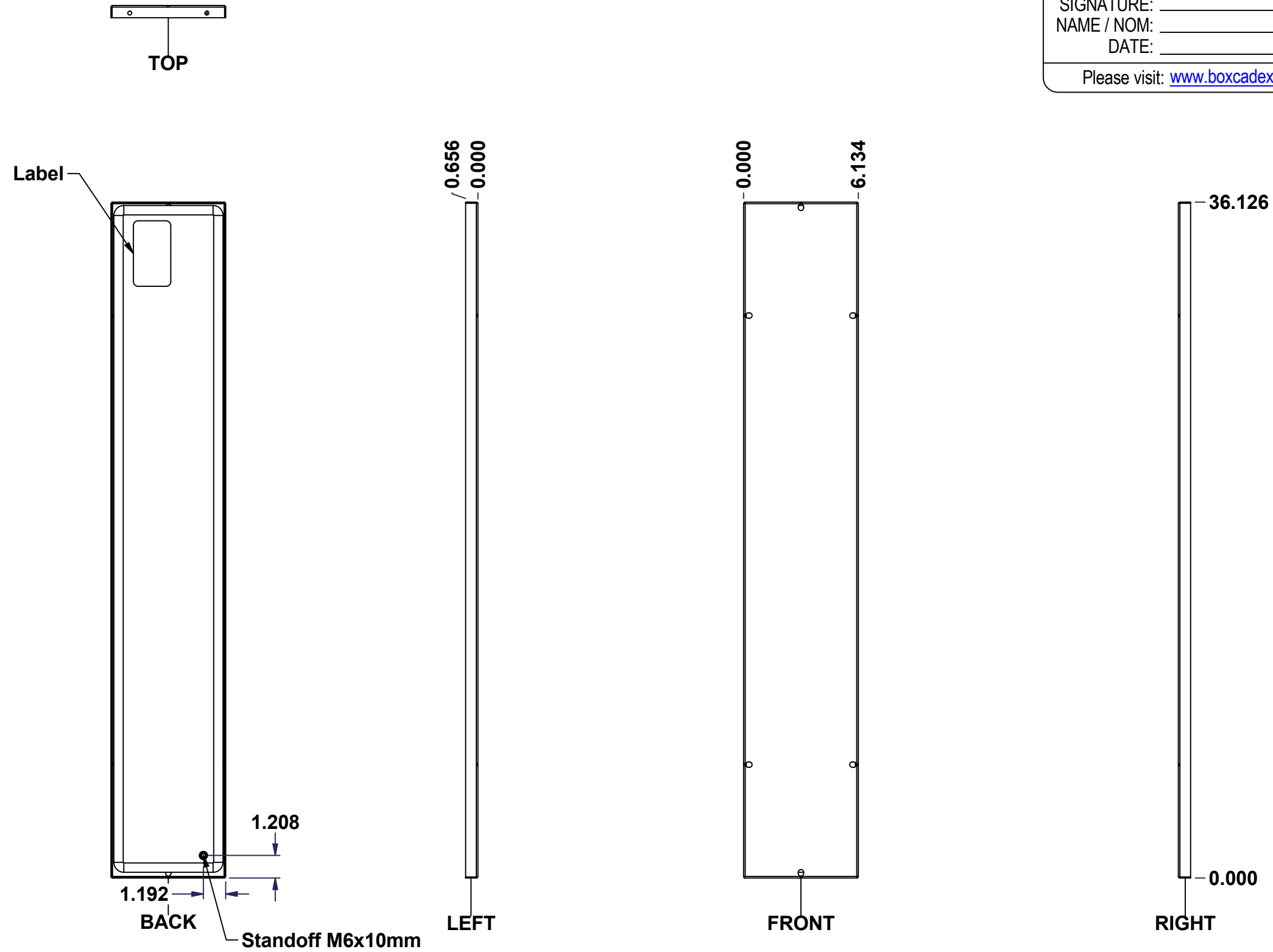

EXM
 Tél: (450) 979-4373
 Fax: (450) 979-4626
www.exmweb.com

Flatness
 Aplatissement
 Max 3.0mm

Projection

Customer Client _____ Date _____

Drawn By / Dessiné Par: BoxCad: ArthurC Date: 20-Oct-20

Material / Matière: 16 Ga H.R.P. & O. (1.4mm)

Color / Couleur: Asa-61 Grey Finish / Fini: Smooth

Description: 1412T373 Cover Detail Rev. _____

Part Number / Numéro Pièce: **1412T373C** Rev. **0**

Qty	Part Number	Rev.	Description
1	STK-P-02400S	0	Powder Paint (Asa-61 Grey / Smooth)
1	STK-S-00100	0	3.5" x 2" Silver Milar Flexcon Sticker
1	STANDOFF_M6 x 10mm	5	Standoff M6 x 10mm
1	1412T373G	0	1412T373 Gasket
1	1412T373C-P	0	1412T373 Cover Part

Parts List

This drawing is confidential and must not be reproduced or used without the consent of EXM

Ce dessin est confidentiel et ne doit pas être reproduit ou utilisé sans le consentement de EXM

APPROVED FOR PRODUCTION
APPROUVÉ POUR PRODUCTION
 SIGNATURE: _____
 NAME / NOM: _____
 DATE: _____
 Please visit: www.boxcadexm.com

No.	Revisions	Date	By/Par

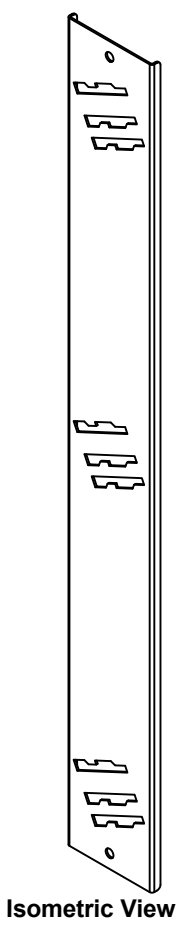
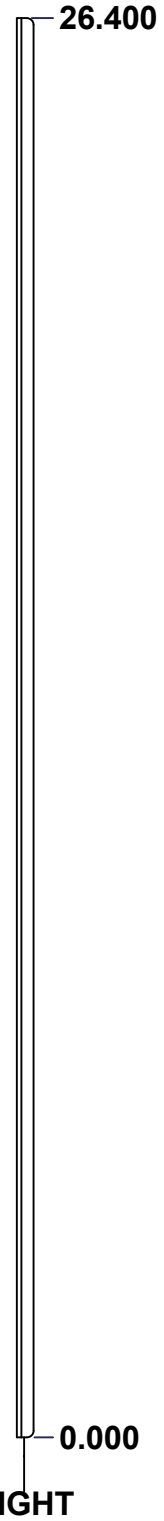
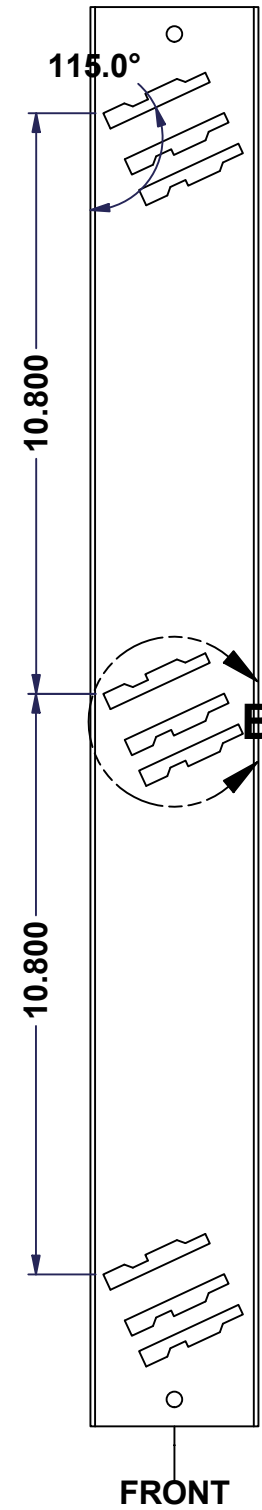
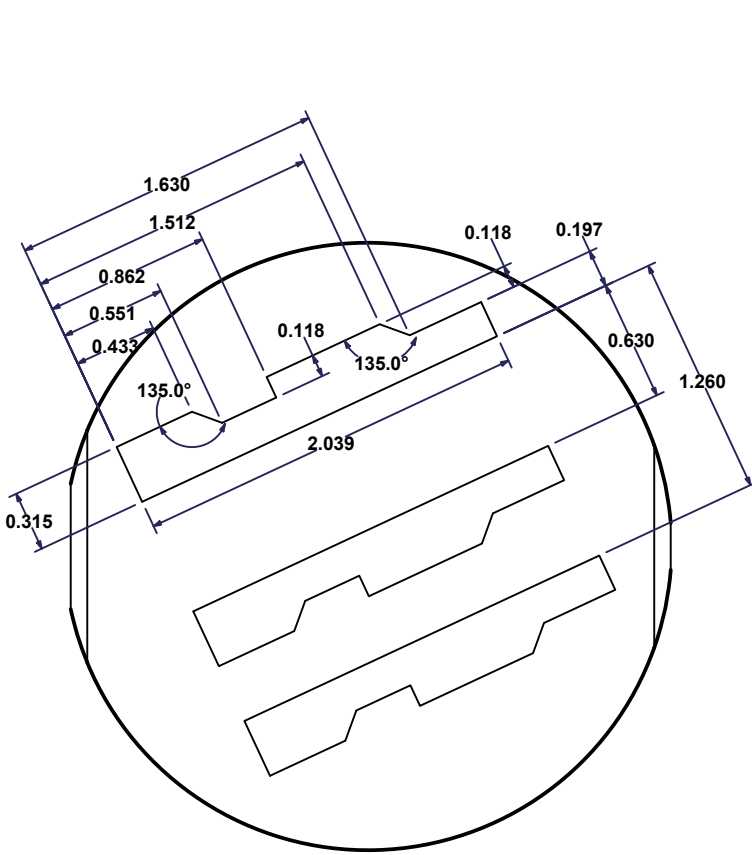

Tél: (450) 979-4373 Fax: (450) 979-4626 www.exmweb.com		Flatness Aplatissement Max 3.0mm Projection
Customer Client	Date	
Drawn By / Dessiné Par: BoxCad: Patrick Deschênes	Date: 10/21/2020	
Material / Matière: 16 Ga Galvanized (1.4mm)	Color / Couleur: Unpainted	
	Finish / Fini: Galvanized	
Description: 1412T373 Inner Panel		Detail Rev.
Part Number / Numéro Pièce: 1412T373IP	Rev.:	5
	0	5

Qty	Part Number	Rev.	Description
1	1412T373IP-P	0	1412T373 Inner Panel

Parts List