

This drawing is confidential and must not be reproduced or used without the consent of EXM

Ce dessin est confidentiel et ne doit pas être reproduit ou utilisé sans le consentement de EXM

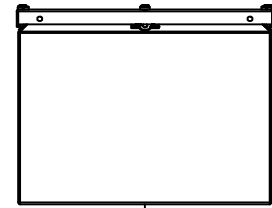

TOP

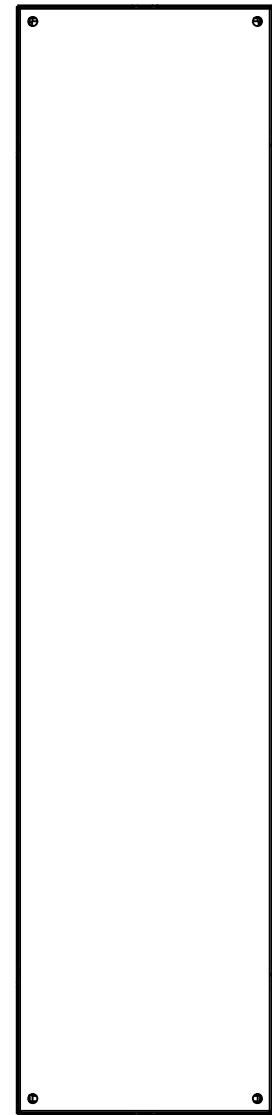

BACK

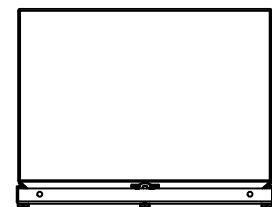

BOTTOM

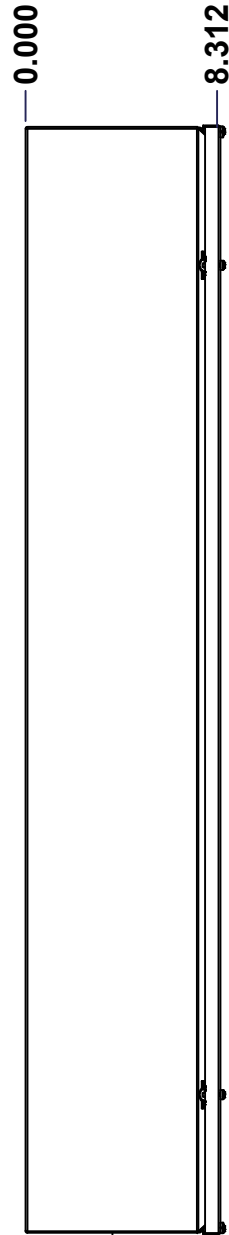

LEFT

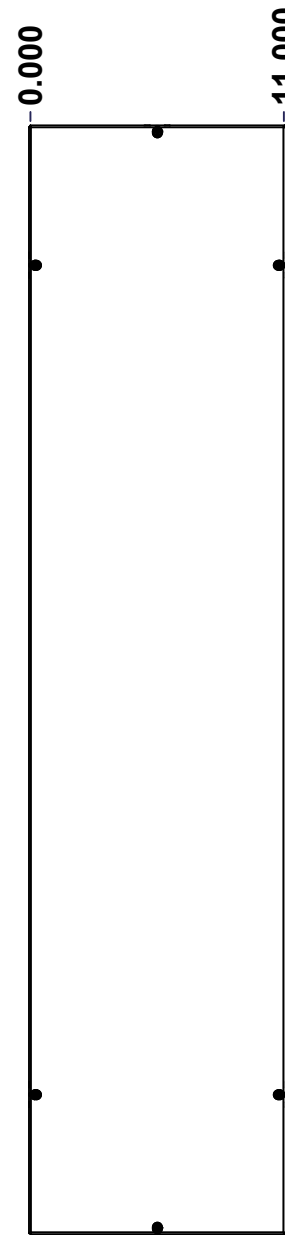

FRONT

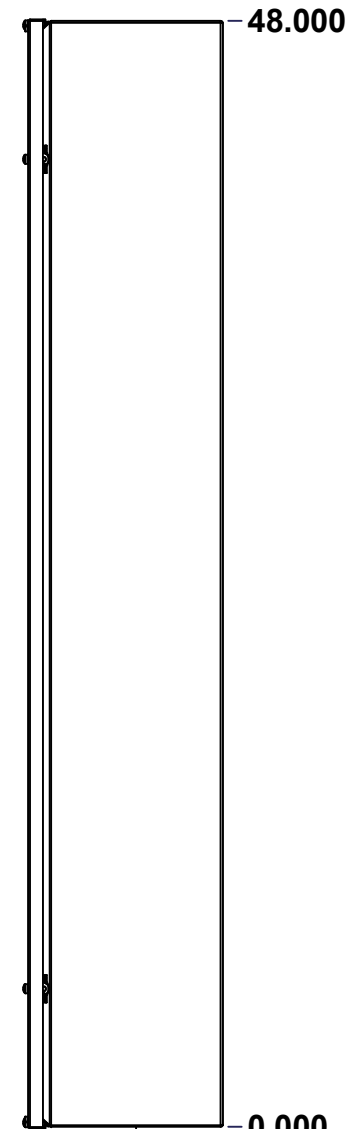

RIGHT

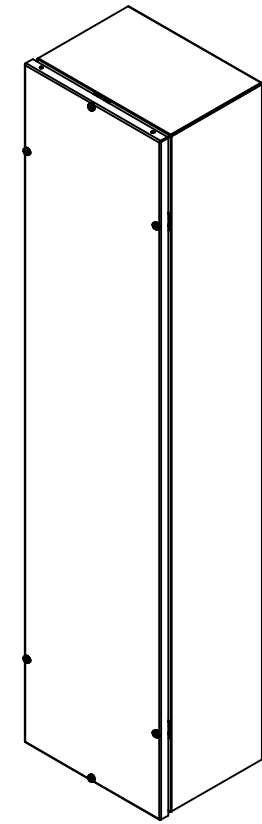

Isometric View



APPROVED FOR PRODUCTION
APPROUVÉ POUR PRODUCTION
 SIGNATURE: _____
 NAME / NOM: _____
 DATE: _____
 Please visit: www.boxcadexm.com

| No. | Revisions | Date | By/Par |
|-----|-----------|------|--------|
| | | | |
| | | | |
| | | | |
| | | | |

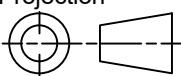
| | | |
|--|---------------------------|---|
|  Tél: (450) 979-4373 Fax: (450) 979-4626 www.exmweb.com | | Flatness Aplatissement Max 3.0mm Projection  |
| Customer Client | Date | |
| Drawn By Dessiné Par | BoxCad: ArthurC | Date 20-Oct-20 |
| Material Matière | 16 Ga H.R.P. & O. (1.4mm) | |
| Color Couleur | Asa-61 Grey | Finish Fini Smooth |
| Description | Detail Rev. | |
| 1412T4404 Assembly | | |
| Part Number Numéro Pièce | Rev. 0 | 1 / 5 |
| 1412T4404 | | |

This drawing is confidential and must not be reproduced or used without the consent of EXM

Ce dessin est confidentiel et ne doit pas être reproduit ou utilisé sans le consentement de EXM

| NOTE | |
|------|--|
| ITEM | DESCRIPTION |
| 1 | NEMA/EEMAC 3R-4-12 Enclosure |
| 2 | C/W Standard ground standoffs on box and cover |
| 3 | W/O Standard door stiffener |
| 4 | C/W Inner panel |
| 5 | C/W Inner panel mounting standoffs |

APPROVED FOR PRODUCTION
APPROUVÉ POUR PRODUCTION
 SIGNATURE: _____
 NAME / NOM: _____
 DATE: _____
 Please visit: www.boxcadexm.com

| No. | Revisions | Date | By/Par |
|-----|-----------|------|--------|
| | | | |
| | | | |
| | | | |
| | | | |
| | | | |

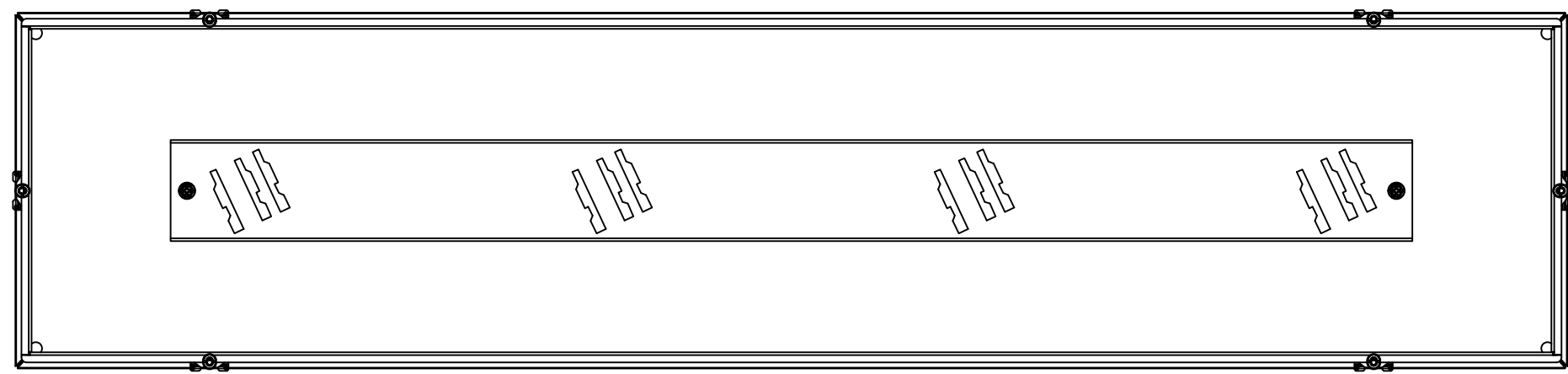

View Without Cover

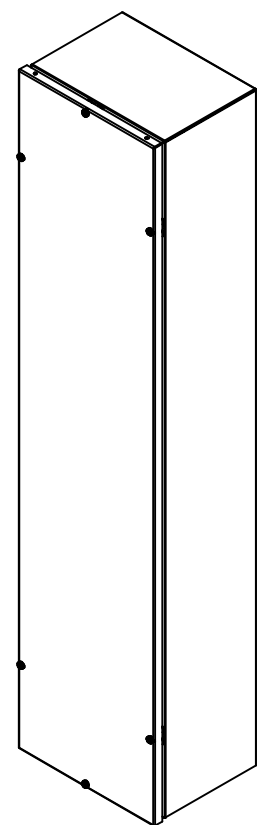

Isometric View

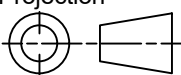

| | | |
|--|---------------------------|---|
|  Tél: (450) 979-4373 Fax: (450) 979-4626 www.exmweb.com | Flatness Aplatissement | Max 3.0mm |
| | Projection |  |
| Customer Client | Date | |
| Drawn By Dessiné Par | BoxCad: ArthurC | Date 20-Oct-20 |
| Material Matière | 16 Ga H.R.P. & O. (1.4mm) | |
| Color Couleur | Asa-61 Grey | Finish Fini Smooth |
| Description | Detail Rev. | |
| 1412T4404 Assembly | | |
| Part Number Numéro Pièce | Rev. 0 | 2 / 5 |
| 1412T4404 | | |

| | | | |
|------------|-------------|------|--|
| 1 | STK-K-02910 | 3 | 5412 ESCH Accessory Kit |
| 2 | STK-Q-03200 | 0 | M6 x 8mm Hexagon/Slot Screw |
| 1 | 1412T4404IP | 0 | 1412T4404 Inner Panel |
| 6 | STK-Q-03035 | 4 | Stainless Steel 316 Phillips Oval Head Screw M5 x 18.5mm (Pitch 0.8mm) |
| 6 | STK-Q-77280 | 5 | 5412 ESSC M5 Countersink Insert (Flat Hole) |
| 1 | 1412T4404C | 0 | 1412T4404 Cover |
| 1 | 1412T4404B | 0 | 1412T4404 Body |
| Qty | Part Number | Rev. | Description |
| Parts List | | | |

This drawing is confidential and must not be reproduced or used without the consent of EXM

Ce dessin est confidentiel et ne doit pas être reproduit ou utilisé sans le consentement de EXM

APPROVED FOR PRODUCTION
APPROUVÉ POUR PRODUCTION
 SIGNATURE: _____
 NAME / NOM: _____
 DATE: _____
 Please visit: www.boxcadexm.com

| No. | Revisions | Date | By/Par |
|-----|-----------|------|--------|
| | | | |
| | | | |
| | | | |
| | | | |

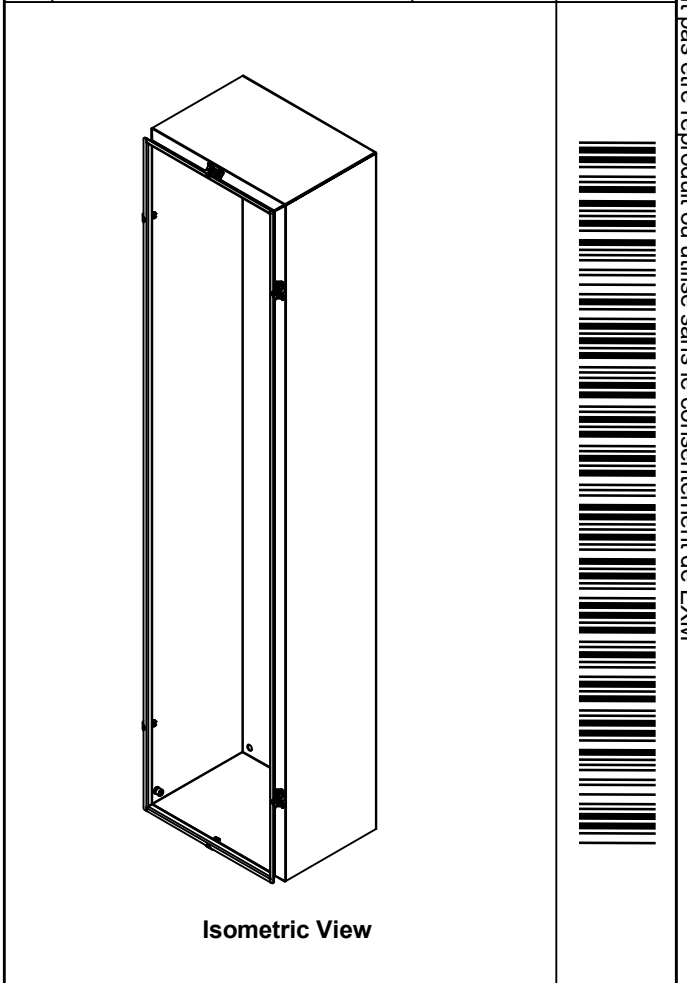
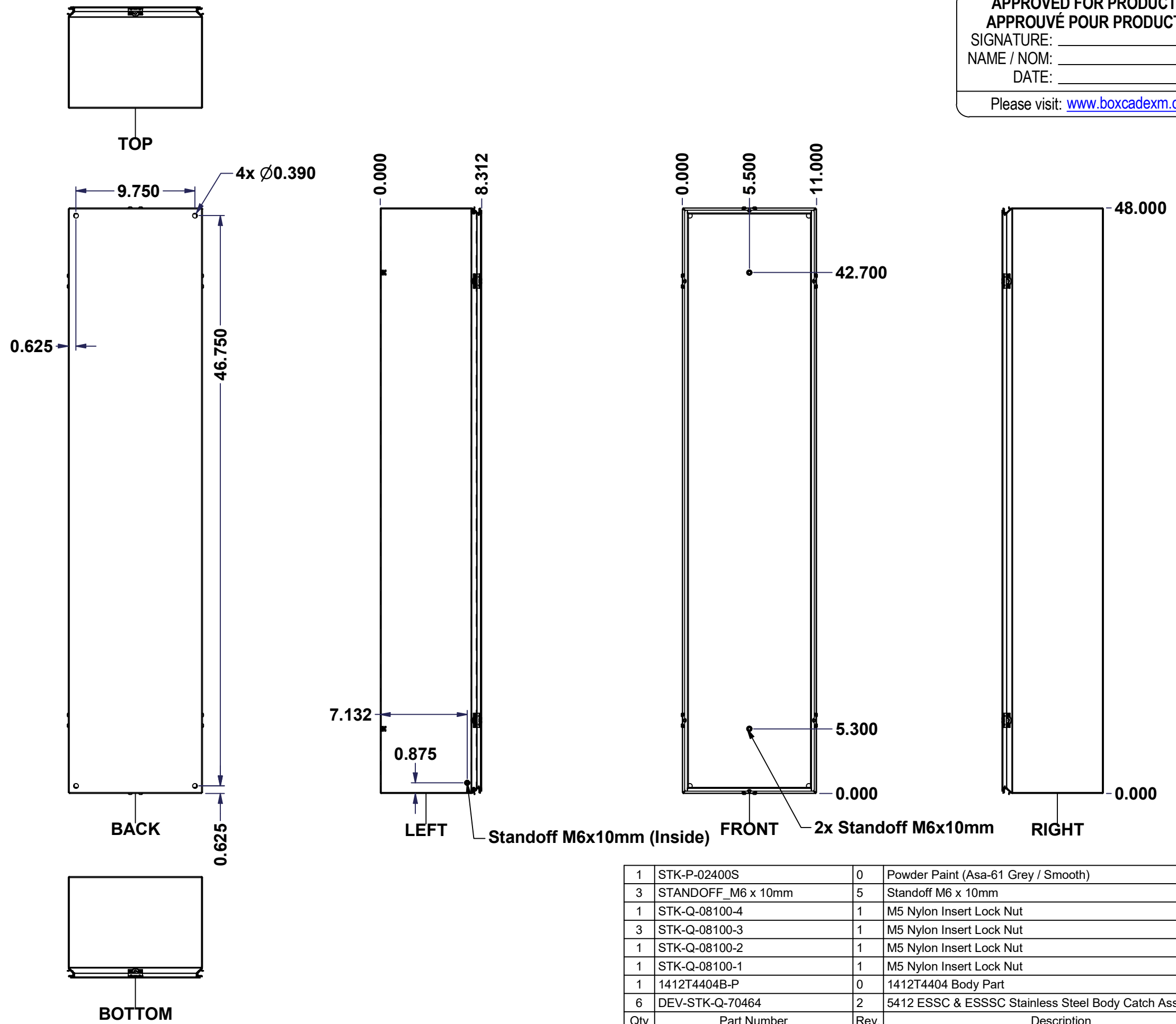

EXM
 Tél: (450) 979-4373
 Fax: (450) 979-4626
www.exmweb.com

Flatness
 Aplatissement
 Max 3.0mm
 Projection

Customer Client _____ Date _____
 Drawn By Dessiné Par BoxCad: ArthurC Date 20-Oct-20

Material Matière 16 Ga H.R.P. & O. (1.4mm)

Color Couleur Asa-61 Grey Finish Fini Smooth

Description 1412T4404 Body Detail Rev. _____

Part Number Numéro Pièce **1412T4404B** Rev. 0 3 5

| Qty | Part Number | Rev. | Description |
|-----|--------------------|------|--|
| 1 | STK-P-02400S | 0 | Powder Paint (Asa-61 Grey / Smooth) |
| 3 | STANDOFF_M6 x 10mm | 5 | Standoff M6 x 10mm |
| 1 | STK-Q-08100-4 | 1 | M5 Nylon Insert Lock Nut |
| 3 | STK-Q-08100-3 | 1 | M5 Nylon Insert Lock Nut |
| 1 | STK-Q-08100-2 | 1 | M5 Nylon Insert Lock Nut |
| 1 | STK-Q-08100-1 | 1 | M5 Nylon Insert Lock Nut |
| 1 | 1412T4404B-P | 0 | 1412T4404 Body Part |
| 6 | DEV-STK-Q-70464 | 2 | 5412 ESSC & ESSC Stainless Steel Body Catch Assembly |

Parts List

This drawing is confidential and must not be reproduced or used without the consent of EXM

Ce dessin est confidentiel et ne doit pas être reproduit ou utilisé sans le consentement de EXM

APPROVED FOR PRODUCTION
APPROUVÉ POUR PRODUCTION
 SIGNATURE: _____
 NAME / NOM: _____
 DATE: _____
 Please visit: www.boxcadexm.com

| No. | Revisions | Date | By/Par |
|-----|-----------|------|--------|
| | | | |
| | | | |
| | | | |
| | | | |
| | | | |

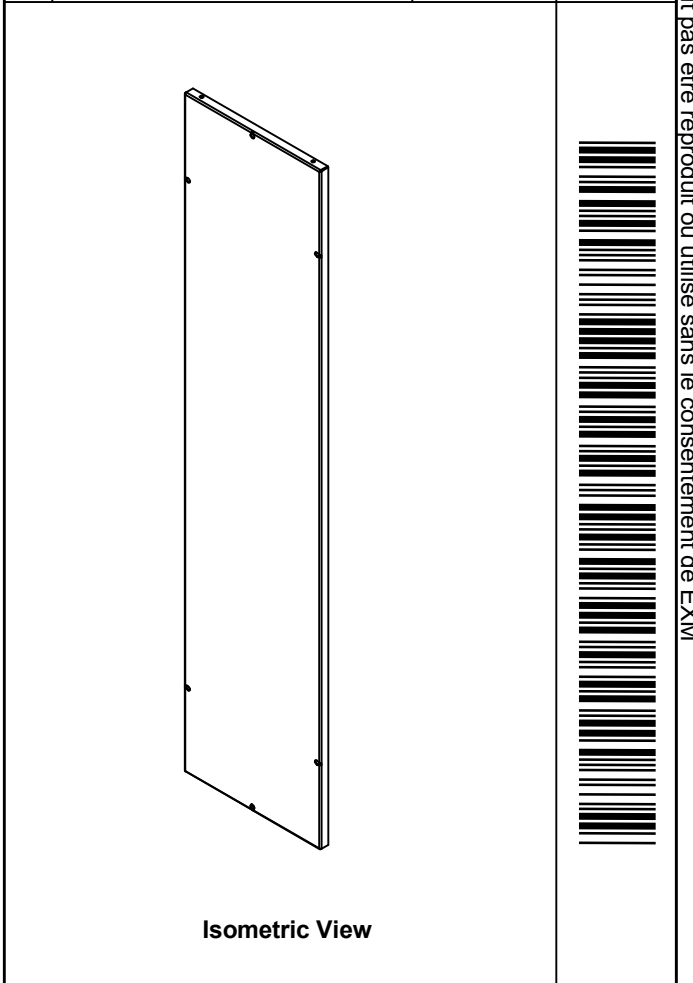
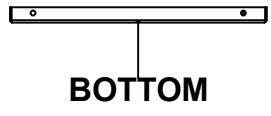
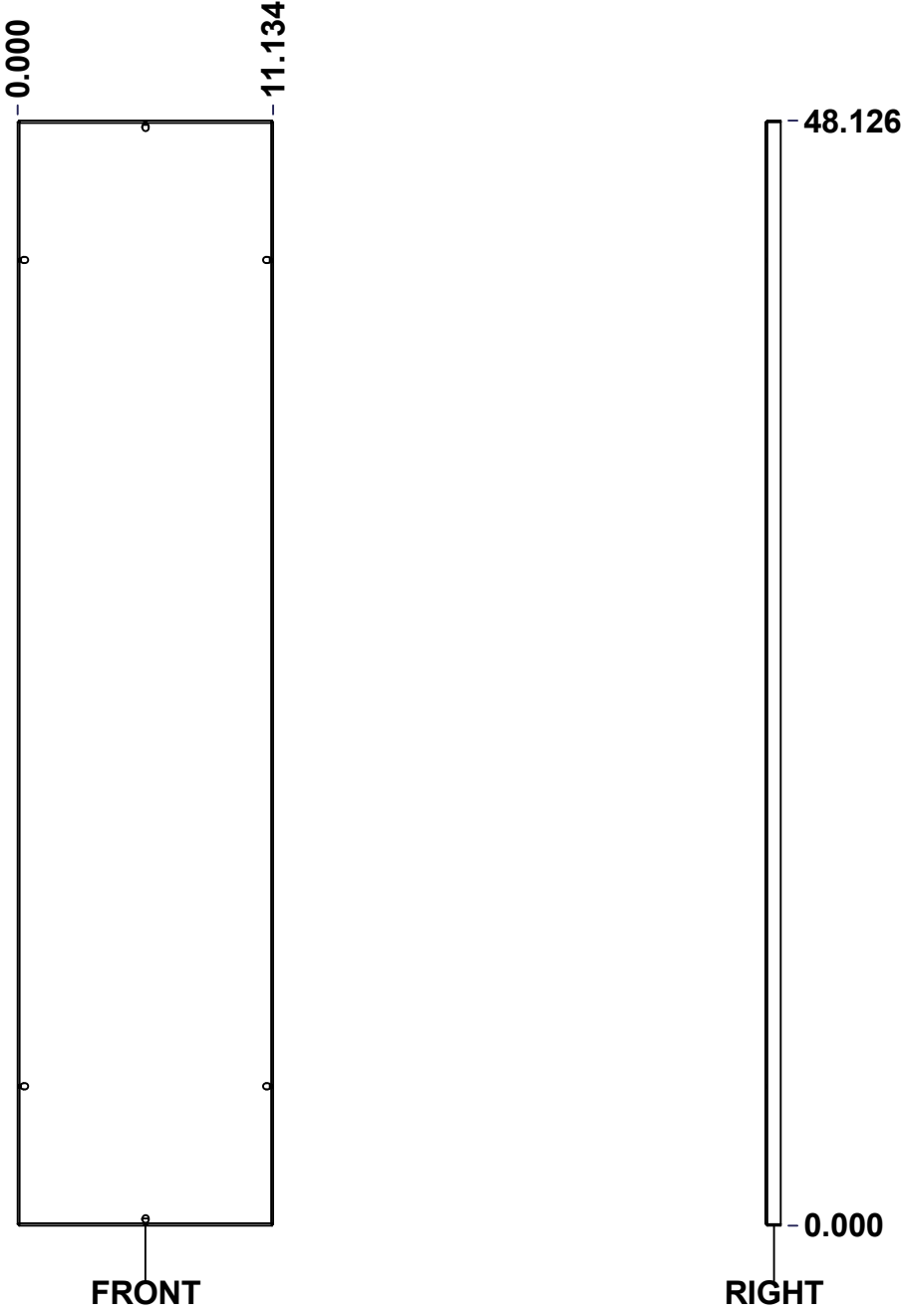
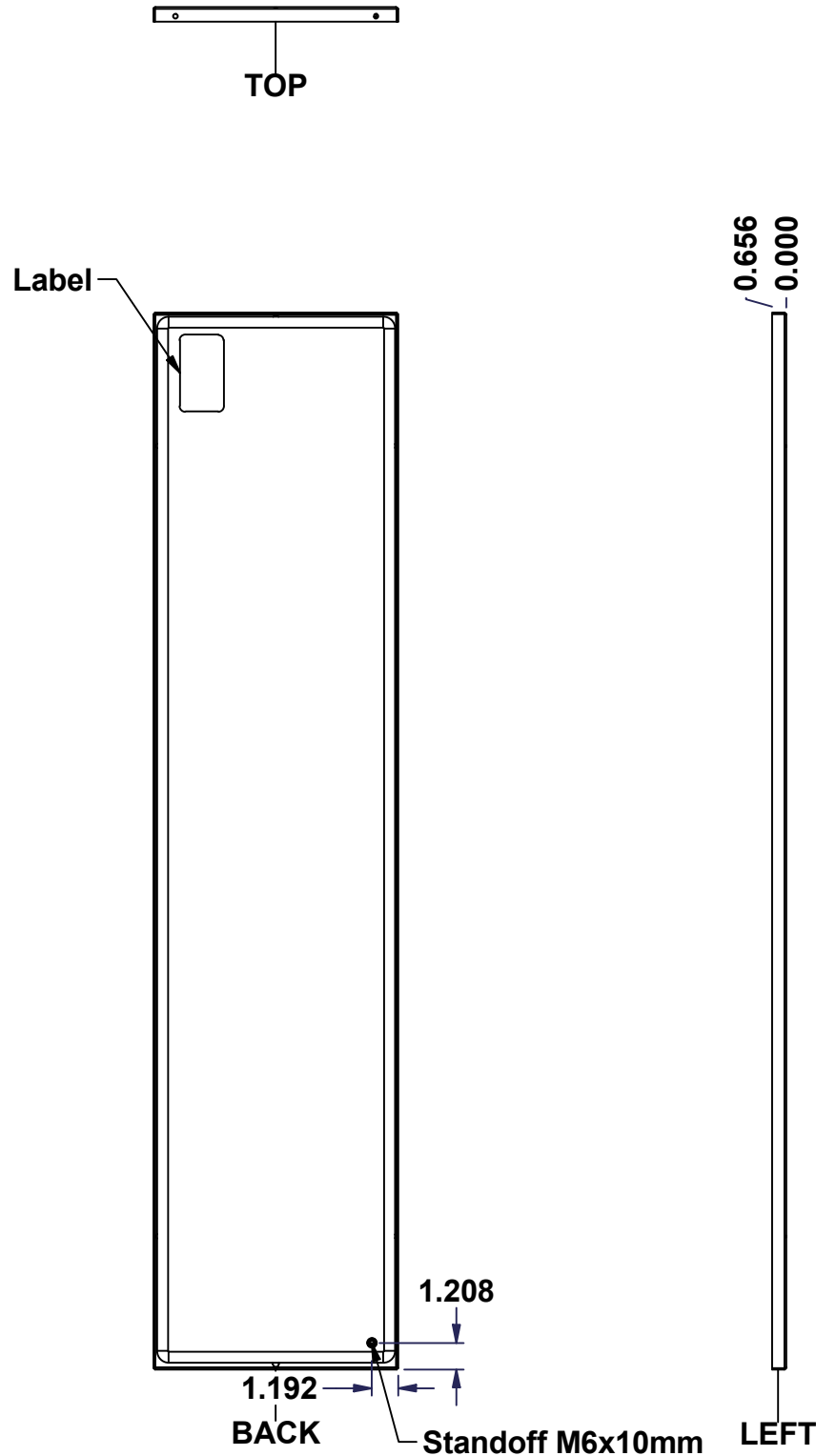

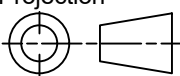
| | | |
|--|------------------------------|---|
|  Tél: (450) 979-4373 Fax: (450) 979-4626 www.exmweb.com | | Flatness Aplatissement Max 3.0mm Projection  |
| Customer Client | Date | |
| Drawn By / Dessiné Par: BoxCad: ArthurC | Date: 20-Oct-20 | |
| Material / Matière: 16 Ga H.R.P. & O. (1.4mm) | Color / Couleur: Asa-61 Grey | |
| | Finish / Fini: Smooth | |
| Description: 1412T4404 Cover | | Detail Rev. |
| Part Number / Numéro Pièce: 1412T4404C | Rev.: | 4 |
| | 0 | 5 |

| Qty | Part Number | Rev. | Description |
|-----|--------------------|------|--|
| 1 | STK-P-02400S | 0 | Powder Paint (Asa-61 Grey / Smooth) |
| 1 | STK-S-00100 | 0 | 3.5" x 2" Silver Milar Flexcon Sticker |
| 1 | STANDOFF_M6 x 10mm | 5 | Standoff M6 x 10mm |
| 1 | 1412T4404G | 0 | 1412T4404 Gasket |
| 1 | 1412T4404C-P | 0 | 1412T4404 Cover Part |

Parts List

This drawing is confidential and must not be reproduced or used without the consent of EXM

Ce dessin est confidentiel et ne doit pas être reproduit ou utilisé sans le consentement de EXM

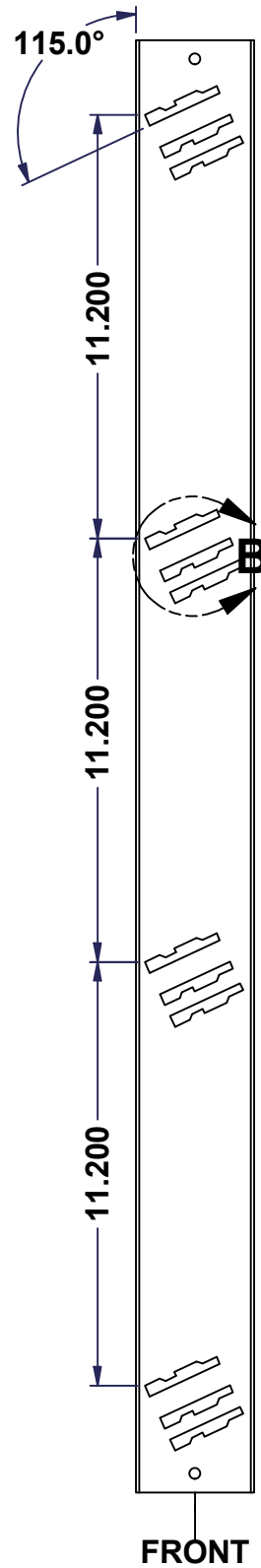
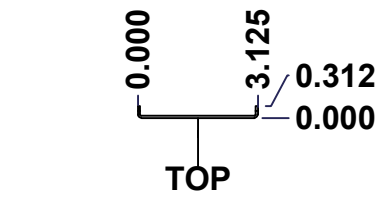
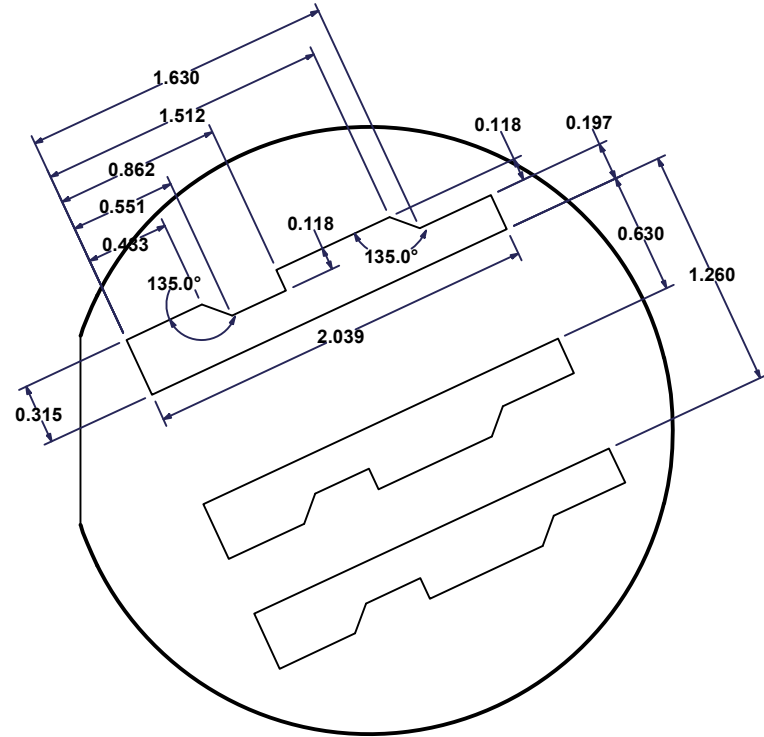

APPROVED FOR PRODUCTION
APPROUVÉ POUR PRODUCTION
 SIGNATURE: _____
 NAME / NOM: _____
 DATE: _____
 Please visit: www.boxcadexm.com

38.400

RIGHT

0.000

| No. | Revisions | Date | By/Par |
|-----|-----------|------|--------|
| | | | |
| | | | |
| | | | |
| | | | |

Isometric View

| | | |
|--|---------------------------|--|
| Tél: (450) 979-4373 Fax: (450) 979-4626 www.exmweb.com | | Flatness Aplatissement Max 3.0mm Projection |
| Customer Client | Date | |
| Drawn By Dessiné Par | BoxCad: Patrick Deschênes | Date 2020/10/21 |
| Material Matière | 16 Ga Galvanized (1.4mm) | |
| Color Couleur | Unpainted | Finish Fini Galvanized |
| Description 1412T4404 Inner Panel | | Detail Rev. |
| Part Number Numéro Pièce | 1412T4404IP | Rev. 5 0 |

| Qty | Part Number | Rev. | Description |
|-----|---------------|------|-----------------------|
| 1 | 1412T4404IP-P | 0 | 1412T4404 Inner Panel |

Parts List