

This drawing is confidential and must not be reproduced or used without the consent of EXM

Ce dessin est confidentiel et ne doit pas être reproduit ou utilisé sans le consentement de EXM

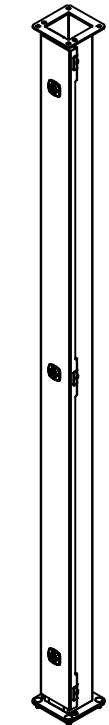

Isometric View

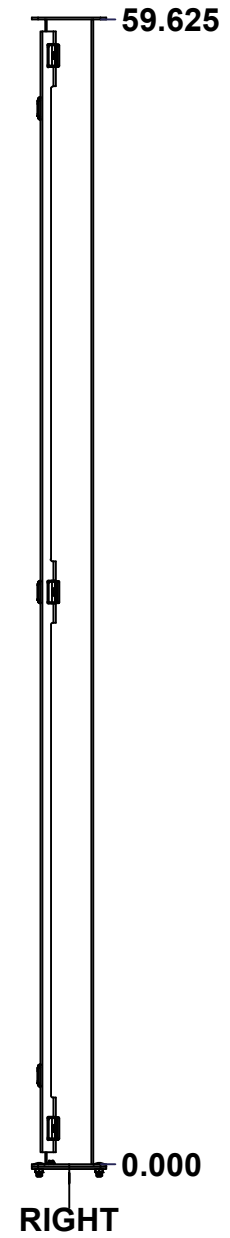
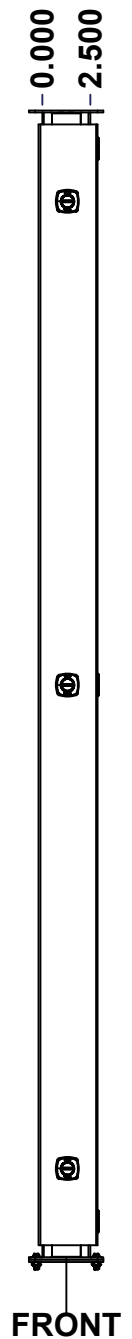
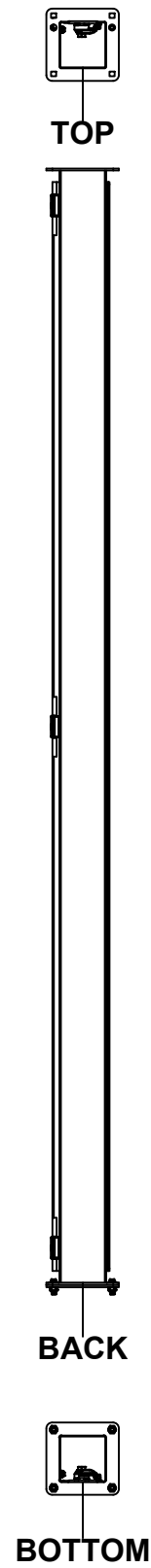

No.	Revisions	Date	By/Par

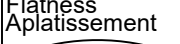
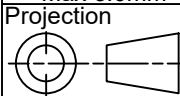
 Tél: (450) 979-4373 Fax: (450) 979-4626 www.exmweb.com		Flatness Aplatissement  Max 3.0mm Projection 
Customer Client	Date	
Drawn By Dessiné Par	BoxCad: HunterZ	Date 21-Apr-23
Material Matière	16 Ga Stainless Steel 304 (1.4mm)	
Color Couleur	Unpainted	Finish Fini Brushed
Description	Detail Rev.	
1412XSS 60" x 2.5" x 2.5" Assembly		
Part Number Numéro Pièce	Rev.	
1412XSS2060	0	1 / 7

SEE BILL OF MATERIAL ON LAST PAGE

This drawing is confidential and must not be reproduced or used without the consent of EXM

Ce dessin est confidentiel et ne doit pas être reproduit ou utilisé sans le consentement de EXM

NOTE	
ITEM	DESCRIPTION
1	NEMA 4X Enclosure

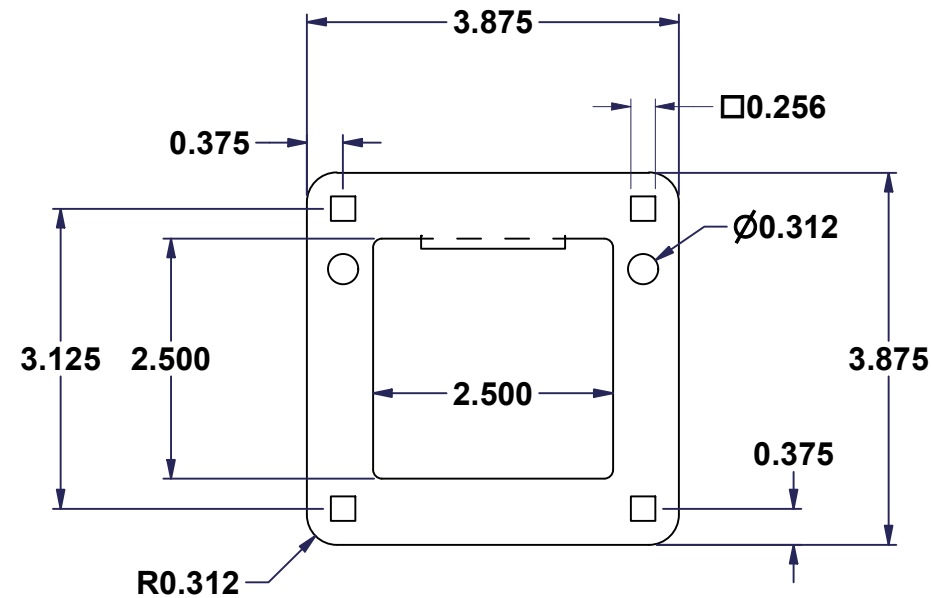

CONNECTOR Details

No.	Revisions	Date	By/Par

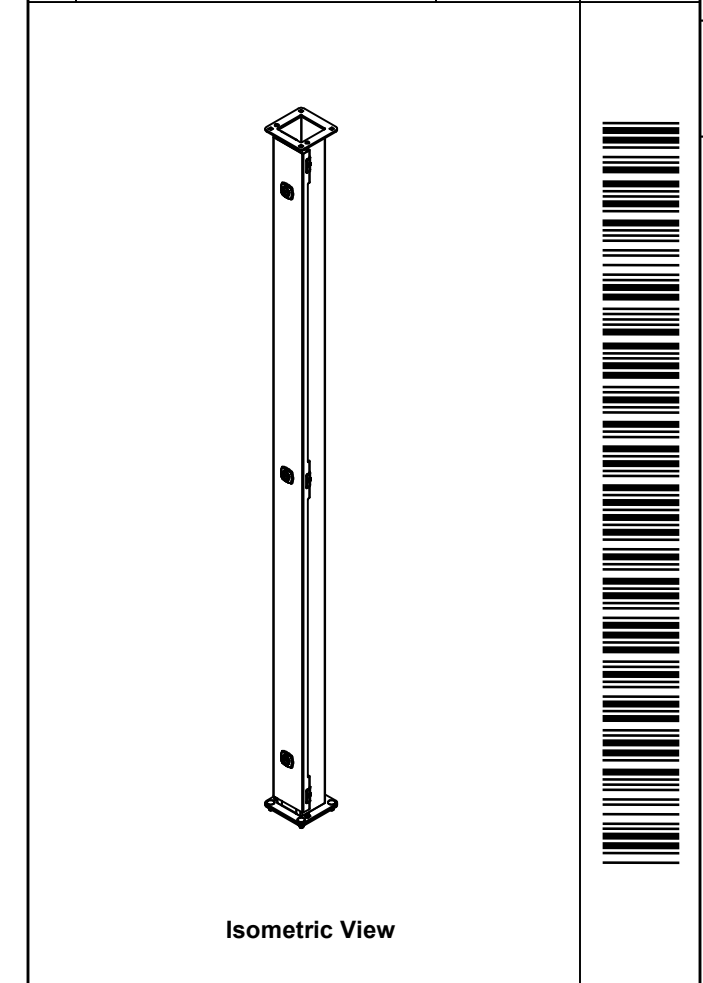

Isometric View

EXM
Tél: (450) 979-4373
Fax: (450) 979-4626
www.exmweb.com



Customer Client	Date
Drawn By / Dessiné Par: BoxCad: HunterZ	Date: 21-Apr-23

Material Matière: 16 Ga Stainless Steel 304 (1.4mm)

Color Couleur: Unpainted	Finish Fini: Brushed
--------------------------	----------------------

Description: 1412XSS 60" x 2.5" x 2.5" Assembly

Part Number / Numéro Pièce: 1412XSS2060	Rev. 0	2 / 7
--	--------	-------

Qty	Part Number	Rev	Description
4	STK-Q-07225	0	M6 Stainless Steel Nylon Insert Lock Nut
4	STK-Q-00266	0	M6 x 16mm Stainless Steel 316 Carriage Bolt
1	STK-G-01600	1	1412 Pull Through Wireway Gasket
2	1412XSS2060BC-P	0	1412XSS 2.5" x 2.5" Connector Part
1	1412XSS2060C	0	1412XSS 60" x 2.5" Cover
1	1412XSS2060B	0	1412XSS 60" x 2.5" x 2.5" Body
3	STK-Q-08100	1	M5 Nylon Insert Lock Nut

Parts List

PACKING		
ITEM	QTY	DESCRIPTION
Cardboard sleeve	2	Top and Bottom
Plastic strap - Black	2	To Squeeze 2 cardboard sleeve together
Packaging label	3	White label with PN

This drawing is confidential and must not be reproduced or used without the consent of EXM

Ce dessin est confidentiel et ne doit pas être reproduit ou utilisé sans le consentement de EXM

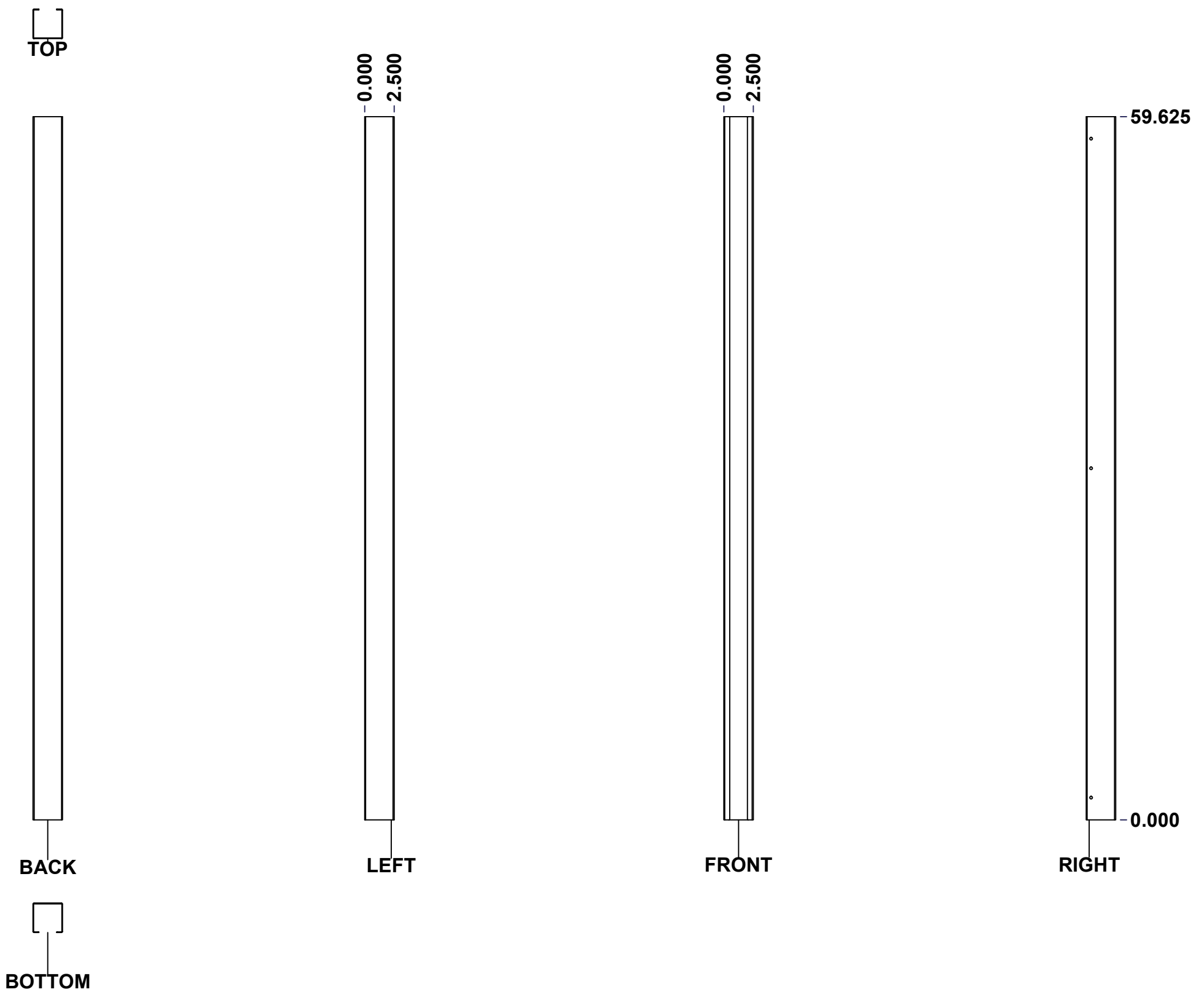

No.	Revisions	Date	By/Par

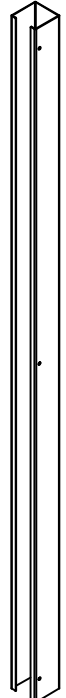

Isometric View

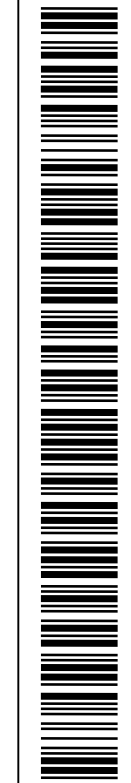

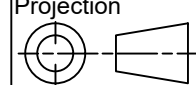
 Tél: (450) 979-4373 Fax: (450) 979-4626 www.exmweb.com		Flatness Aplatissement	
		Max 3.0mm	
Projection			
Customer Client		Date	
Drawn By Dessiné Par BoxCad: HunterZ		Date 21-Apr-23	
Material Matière 16 Ga Stainless Steel 304 (1.4mm)			
Color Couleur Unpainted	Finish Fini Brushed		
Description 1412XSS 60" x 2.5" x 2.5" Body		Detail Rev.	
Part Number Numéro Pièce 1412XSS2060B		Rev. 0	3 7

SEE BILL OF MATERIAL ON LAST PAGE

This drawing is confidential and must not be reproduced or used without the consent of EXM

Ce dessin est confidentiel et ne doit pas être reproduit ou utilisé sans le consentement de EXM

No.	Revisions	Date	By/Par

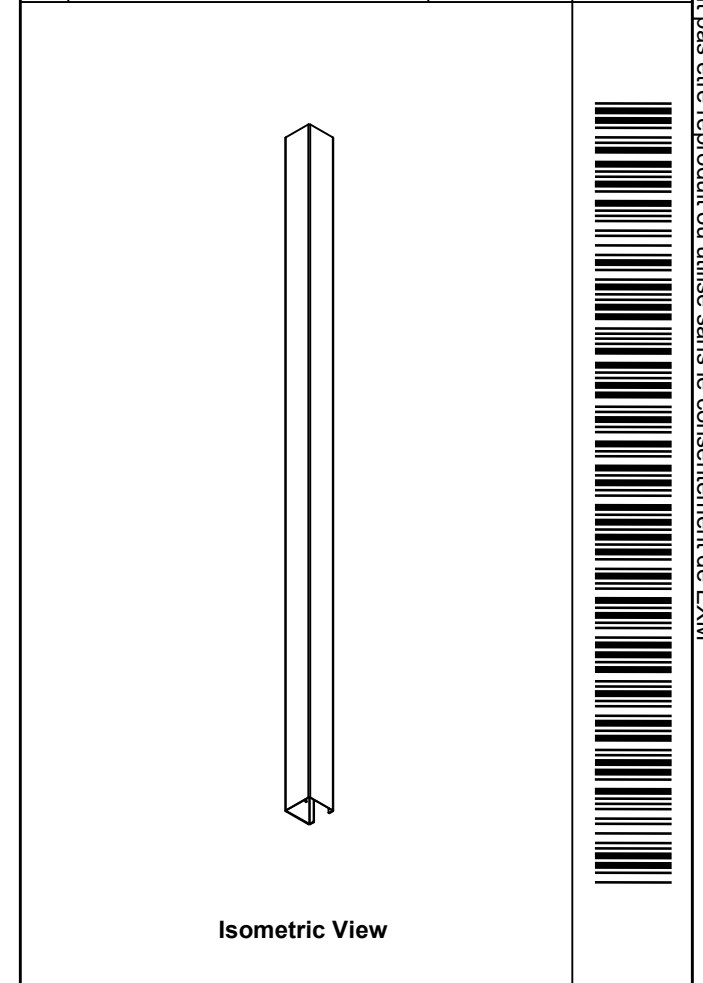

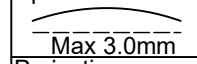
 Tél: (450) 979-4373 Fax: (450) 979-4626 www.exmweb.com		Flatness Aplatissement  Max 3.0mm
Customer Client		Date
Drawn By Dessiné Par BoxCad: HunterZ		Date 21-Apr-23
Material Matière 16 Ga Stainless Steel 304 (1.4mm)		
Color Couleur Unpainted	Finish Fini Brushed	
Description 1412XSS 60" x 2.5" x 2.5" Body		Detail Rev.
Part Number Numéro Pièce 1412XSS2060B		Rev. 0 / 4 7

Qty	Part Number	Rev	Description
1	1412XSS2060B-P	0	1412XSS 60" x 2.5" x 2.5" Body Part
Parts List			

This drawing is confidential and must not be reproduced or used without the consent of EXM

Ce dessin est confidentiel et ne doit pas être reproduit ou utilisé sans le consentement de EXM

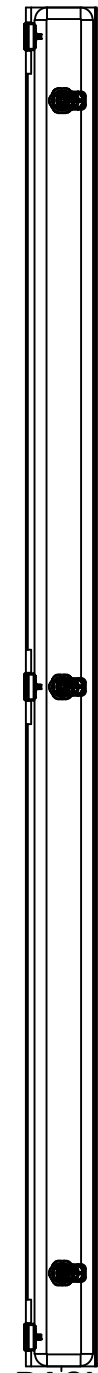

BACK



BOTTOM

0.000
0.660

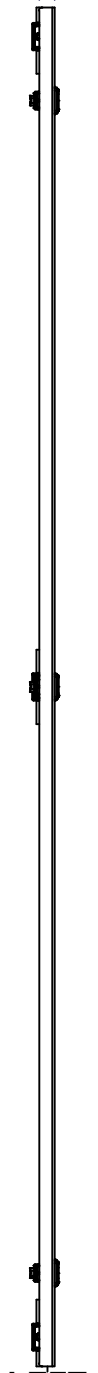

LEFT

0.000
3.065

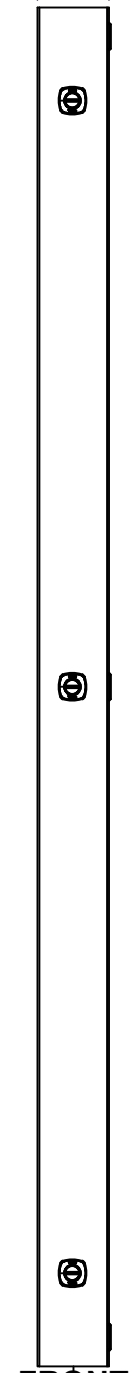

FRONT

58.375

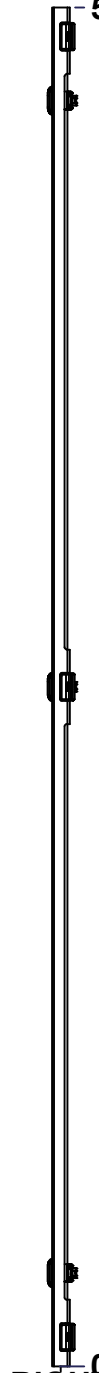

RIGHT

No.	Revisions	Date	By/Par

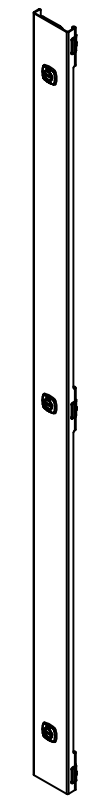

Isometric View



Tél: (450) 979-4373
Fax: (450) 979-4626
www.exmweb.com

Flatness
Aplatissement
Max 3.0mm
Projection

Customer Client	Date
Drawn By / Dessiné Par: BoxCad: HunterZ	Date: 21-Apr-23
Material / Matière: 16 Ga Stainless Steel 304 (1.4mm)	

Color / Couleur: Unpainted	Finish / Fini: Brushed
----------------------------	------------------------

Description: 1412XSS 60" x 2.5" Cover	Detail Rev.
---------------------------------------	-------------

Part Number / Numéro Pièce: 1412XSS2060C	Rev. 0	5 / 7
--	--------	-------

SEE BILL OF MATERIAL ON LAST PAGE

This drawing is confidential and must not be reproduced or used without the consent of EXM

Ce dessin est confidentiel et ne doit pas être reproduit ou utilisé sans le consentement de EXM

STANDARD FEATURES ARE NOT LISTED IN THIS HOLE TABLE			
HOLE TABLE - FRONT VIEW (CUSTOM FEATURE ONLY)			
CUT-OUT	XDIM	YDIM	DESCRIPTION
1	1.565	54.375	LOCK 880 SCQ4CH-SLSS @ 180.0°
2	1.565	29.188	LOCK 880 SCQ4CH-SLSS @ 180.0°
3	1.565	4.000	LOCK 880 SCQ4CH-SLSS @ 180.0°

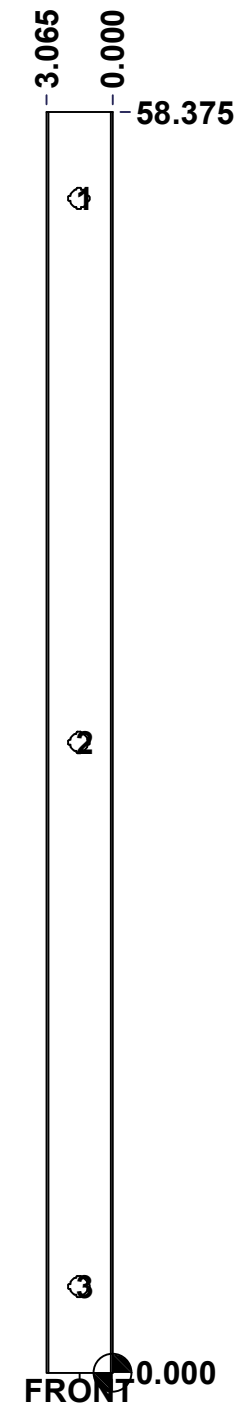

	Description	Status	
	1412XSS 60" x 2.5" x 2.5" Cover	(NULL)	
	Part Number Numéro Pièce	Rev.	
	1412XSS2060C	0	6 / 7

This drawing is confidential and must not be reproduced or used without the consent of EXM

Ce dessin est confidentiel et ne doit pas être reproduit ou utilisé sans le consentement de EXM

No.	Revisions	Date	By/Par



Isometric View

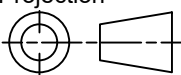

 Tél: (450) 979-4373 Fax: (450) 979-4626 www.exmweb.com	Flatness Aplatissement	Max 3.0mm
	Projection	
Customer Client	Date	
Drawn By Dessiné Par	BoxCad: HunterZ	Date 21-Apr-23
Material Matière	16 Ga Stainless Steel 304 (1.4mm)	
Color Couleur	Unpainted	Finish Fini Brushed
Description	Detail Rev.	
1412XSS 60" x 2.5" Cover		
Part Number Numéro Pièce	Rev.	7
1412XSS2060C	0	7

Qty	Part Number	Rev	Description
1	1412XSS2060G	0	1412XSS 60" x 2.5" Cover Gasket Part
1	1412XSS2060C-P	0	1412XSS 60" x 2.5" x 2.5" Cover Part
3	STK-A-33033	4	5412 ESMCH Hinge
3	880 SCQ4CH-SLSS	0	5412 CHSS 1/4 Turn Lock
Parts List			