

This drawing is confidential and must not be reproduced or used without the consent of EXM

Ce dessin est confidentiel et ne doit pas être reproduit ou utilisé sans le consentement de EXM

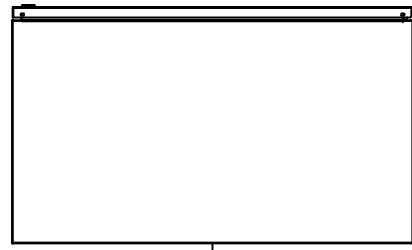

TOP

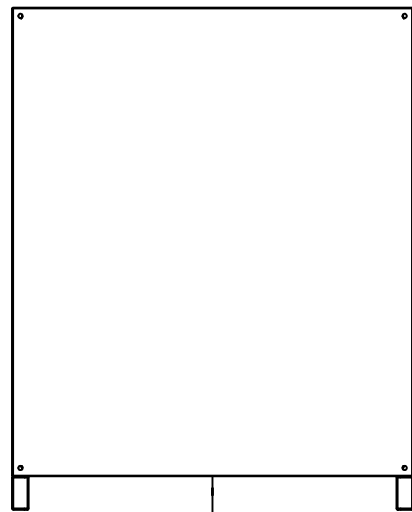

BACK

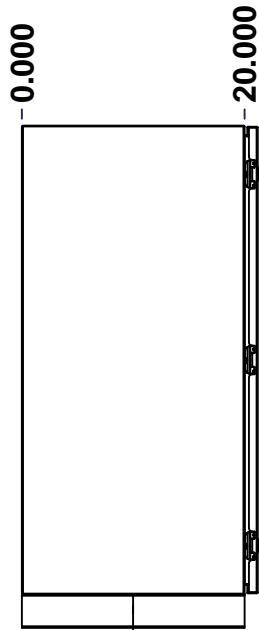

LEFT

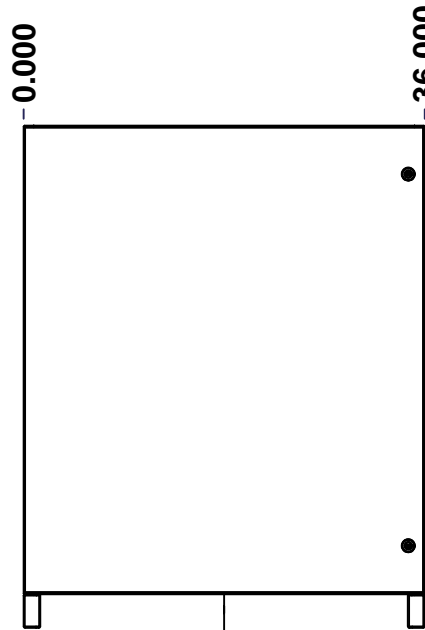

FRONT

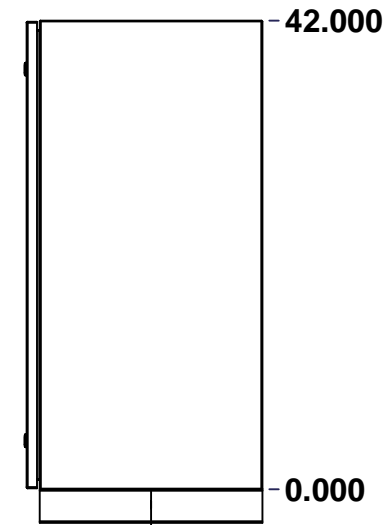



RIGHT

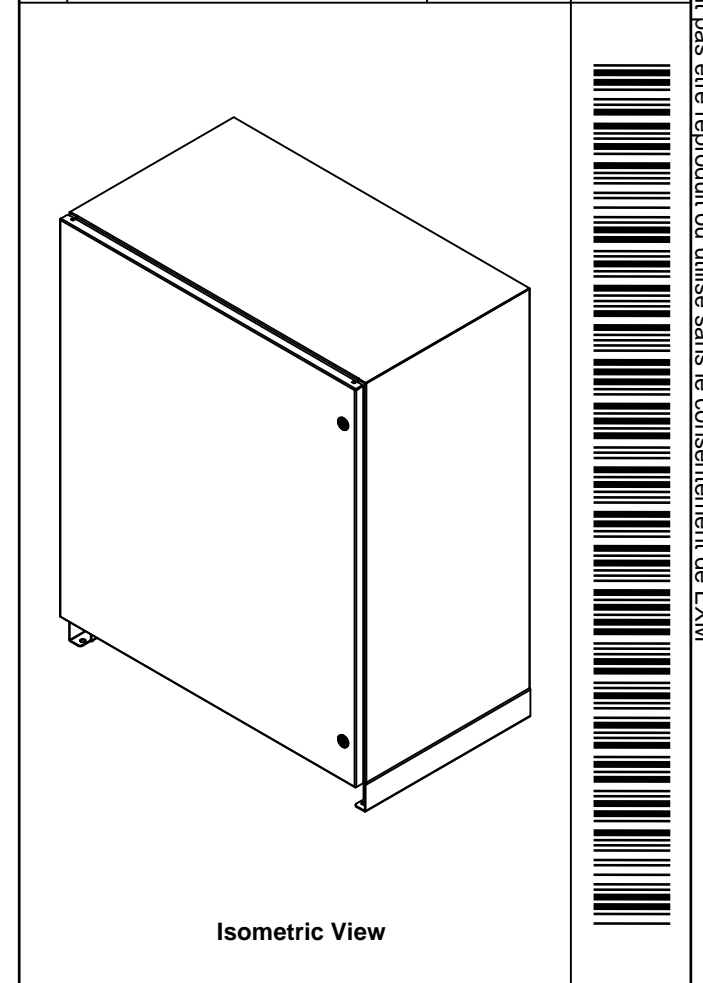

BOTTOM

No.	Revisions	Date	By/Par

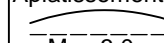
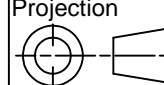

 Tél: (450) 979-4373 Fax: (450) 979-4626 <a href="http://www.exmweb.com">www.exmweb.com</a>		Flatness Aplatissement  Max 3.0mm Projection 
Customer Client	Date	
Drawn By Dessiné Par	BoxCad: Annie	Date 04/02/2015
Material Matière	14 Ga H.R.P. & O. (1.7mm)	
Color Couleur	Asa-61 Grey	Finish Fini Smooth
Description	Detail Rev.	
5100ES 42" x 36" x 20" Assembly		
Part Number Numéro Pièce	Rev.	1
<b>5100ESFS423620</b>	<b>0</b>	2

SEE BILL OF MATERIAL ON LAST PAGE

This drawing is confidential and must not be reproduced or used without the consent of EXM

Ce dessin est confidentiel et ne doit pas être reproduit ou utilisé sans le consentement de EXM

NOTE	
ITEM	DESCRIPTION
1	NEMA 1 Enclosure
2	C/W Standard ground studs on box and cover
3	W/O Standard door stiffener
4	C/W Standard inner panel (Sold seperately)
5	C/W Standard inner panel mounting studs
6	C/W Mounting feet sold seperately (Welded)

No.	Revisions	Date	By/Par

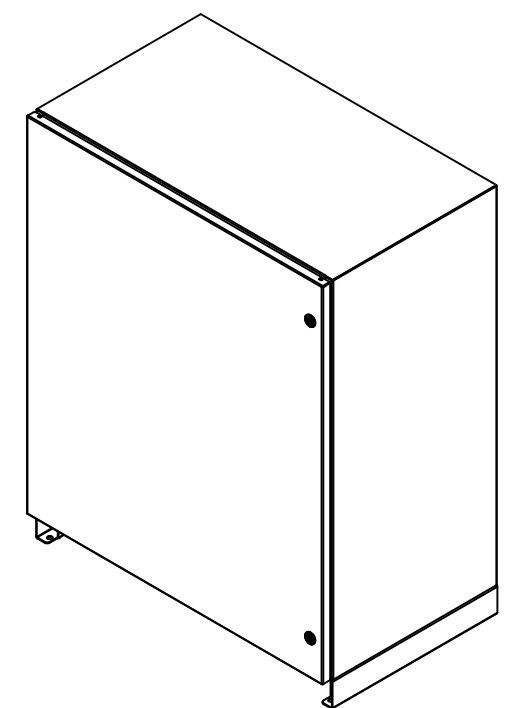

Isometric View

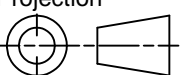

 Tél: (450) 979-4373 Fax: (450) 979-4626 <a href="http://www.exmweb.com">www.exmweb.com</a>	Flatness Aplatissement
	Max 3.0mm
Projection	
Customer Client	Date
Drawn By Dessiné Par BoxCad: Annie	Date 04/02/2015
Material Matière	14 Ga H.R.P. & O. (1.7mm)
Color Couleur	Asa-61 Grey
Finish Fini	Smooth
Description	5100ES 42" x 36" x 20" Assembly
Part Number Numéro Pièce	Rev. 2
<b>5100ESFS423620</b>	<b>0</b>

Qty	Part Number	Rev	Description
1	STK-K-03000	1	5100 ES Accessory Kit
1	881 SP4236	0	881 SP - Inner Panel
1	5100ESFS423620C	0	5100ES 42" x 36" Cover
8	STK-Q-07310	2	Flange Lock Nut M8
1	5100ESFS423620B	0	5100ES 42" x 36" x 20" Body
8	STK-Q-07610	7	M8 Plastic Spacer 22.2mm
3	STK-Q-04050-07	5	M6 x 7mm Hexagon Socket Head Machine Screw with Nyseal
Parts List			

This drawing is confidential and must not be reproduced or used without the consent of EXM

Ce dessin est confidentiel et ne doit pas être reproduit ou utilisé sans le consentement de EXM

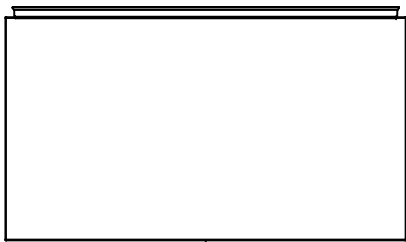

TOP

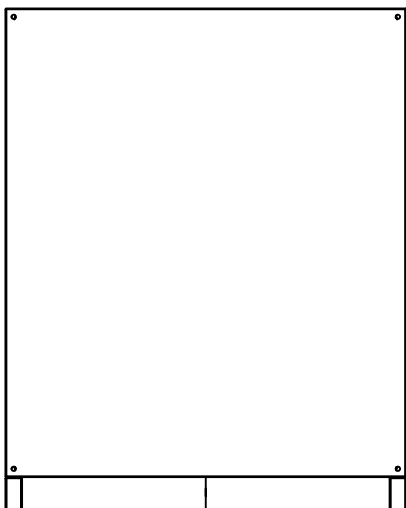

BACK

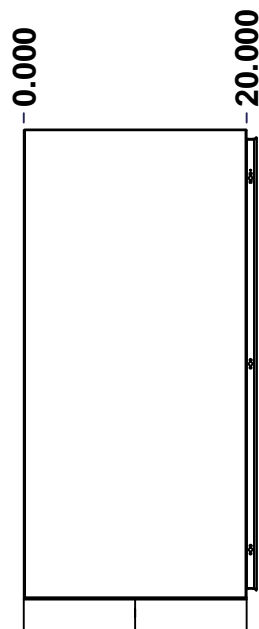

LEFT

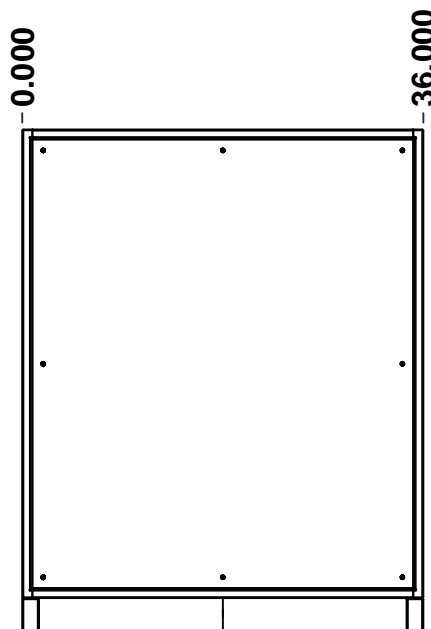

FRONT

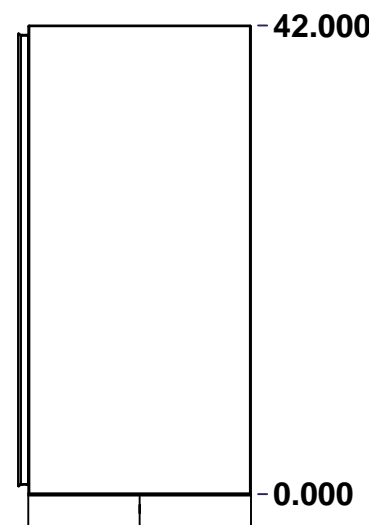

RIGHT



BOTTOM

No.	Revisions	Date	By/Par

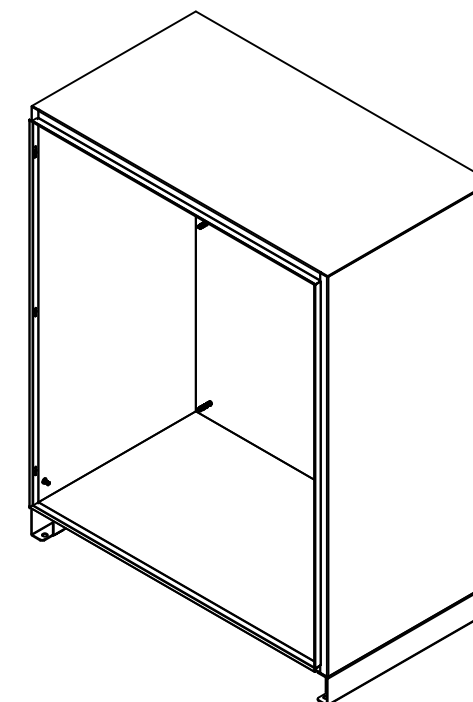

Isometric View



Tél: (450) 979-4373  
 Fax: (450) 979-4626  
[www.exmweb.com](http://www.exmweb.com)

Flatness  
Aplatissement

Max 3.0mm

Projection

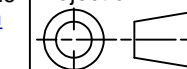

Customer Client	Date
Drawn By / Dessiné Par: BoxCad: Annie	Date: 04/02/2015

Material / Matière: 14 Ga H.R.P. & O. (1.7mm)

Color / Couleur: Asa-61 Grey      Finish / Fini: Smooth

Description: 5100ES 42" x 36" x 20" Body      Detail Rev.

Part Number / Numéro Pièce: <b>5100ESFS423620B</b>	Rev. 0	1 / 7
--	--------	-------

SEE BILL OF MATERIAL ON LAST PAGE

This drawing is confidential and must not be reproduced or used without the consent of EXM

Ce dessin est confidentiel et ne doit pas être reproduit ou utilisé sans le consentement de EXM

<b>STANDARD FEATURES ARE NOT LISTED IN THIS HOLE TABLE</b>			
<b>HOLE TABLE - LEFT VIEW (CUSTOM FEATURE ONLY)</b>			
CUT-OUT	XDIM	YDIM	DESCRIPTION
1	18.500	1.932	GND STUD M6 x 16mm (Inside)

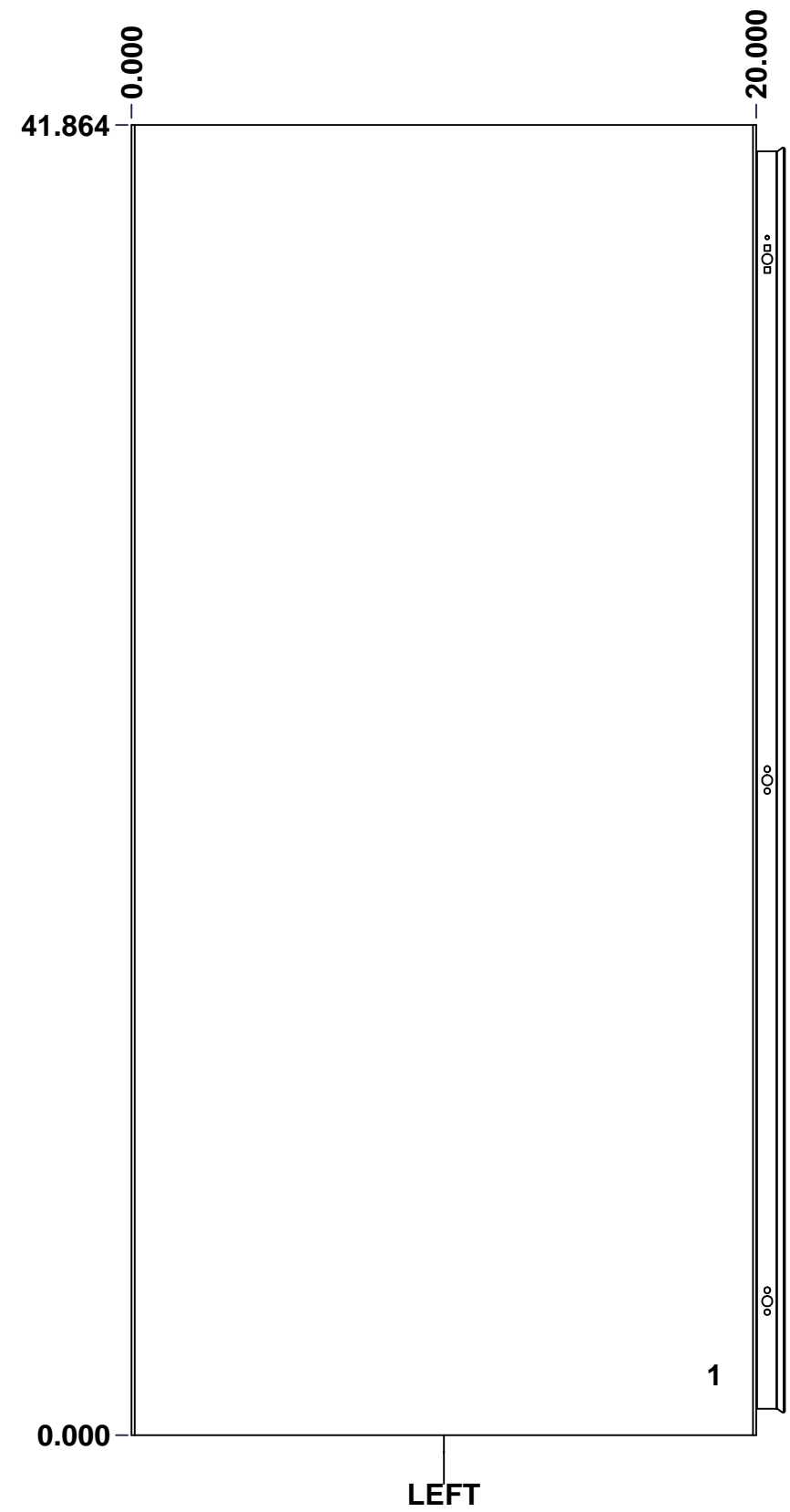

	Description		Status	
	5100ES 42" x 36" x 20" Body			
Part Number Numéro Pièce		Rev.		
<b>5100ESFS423620B</b>		<b>0</b>	5	7

This drawing is confidential and must not be reproduced or used without the consent of EXM

Ce dessin est confidentiel et ne doit pas être reproduit ou utilisé sans le consentement de EXM

**STANDARD FEATURES ARE NOT LISTED IN THIS HOLE TABLE**

**HOLE TABLE - BACK VIEW (CUSTOM FEATURE ONLY)**

CUT-OUT	XDIM	YDIM	DESCRIPTION
1	1.875	1.807	IP STUD M8 x 35mm (Inside)
2	1.875	40.057	IP STUD M8 x 35mm (Inside)
3	34.125	40.057	IP STUD M8 x 35mm (Inside)
4	34.125	1.807	IP STUD M8 x 35mm (Inside)
5	1.875	20.932	IP STUD M8 x 35mm (Inside)
6	34.125	20.932	IP STUD M8 x 35mm (Inside)
7	18.000	1.807	IP STUD M8 x 35mm (Inside)
8	18.000	40.057	IP STUD M8 x 35mm (Inside)

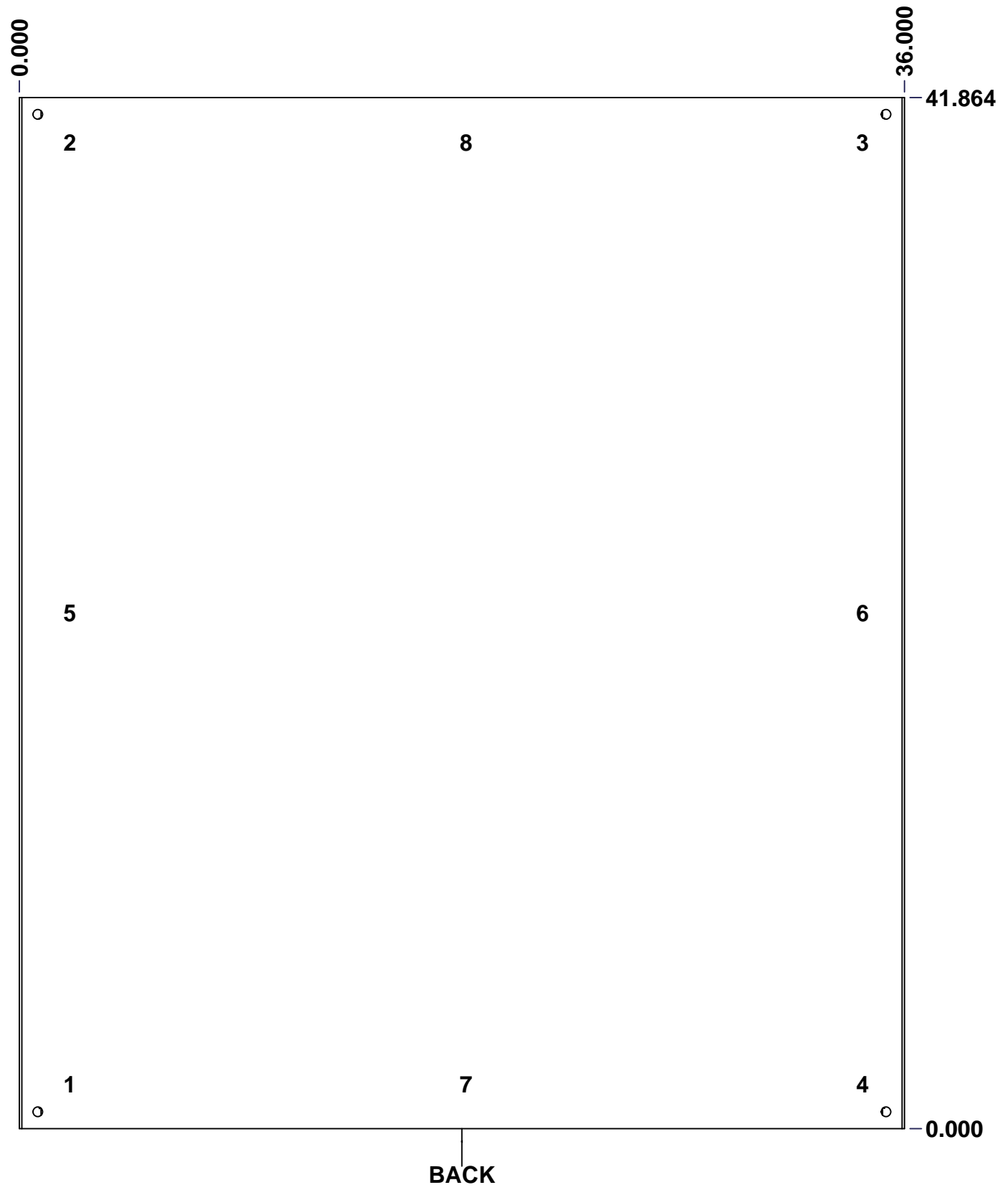

	Description	Status
	5100ES 42" x 36" x 20" Body	
	Part Number Numéro Pièce	Rev.
	<b>5100ESFS423620B</b>	<b>0</b>
		6
		7

This drawing is confidential and must not be reproduced or used without the consent of EXM

Ce dessin est confidentiel et ne doit pas être reproduit ou utilisé sans le consentement de EXM

No.	Revisions	Date	By/Par

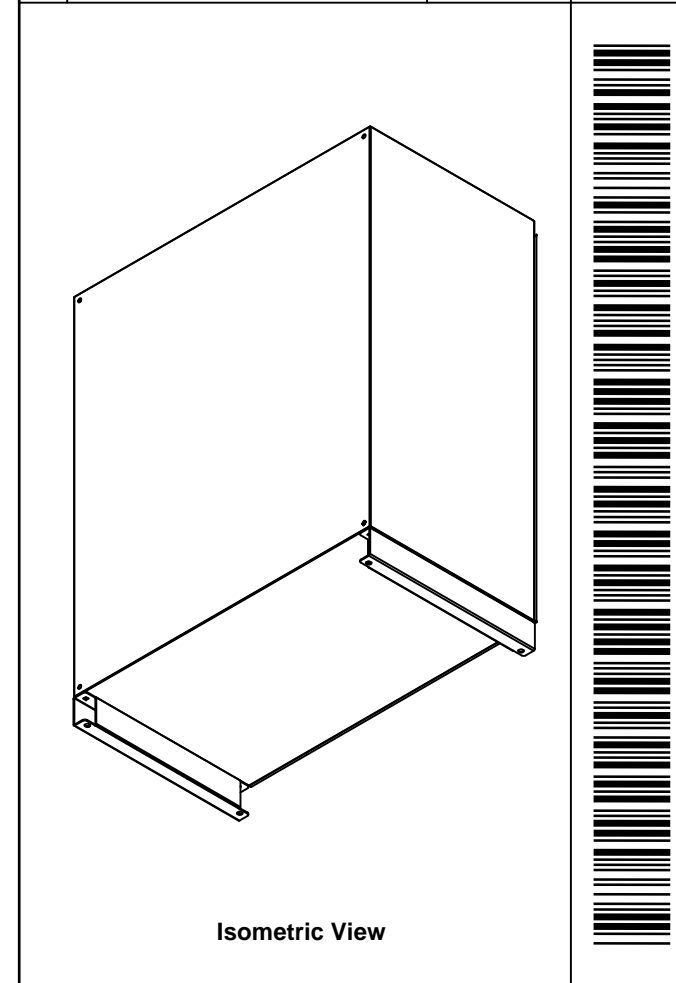

Tél: (450) 979-4373 Fax: (450) 979-4626 <a href="http://www.exmweb.com">www.exmweb.com</a>		Flatness Aplatissement	
		Max 3.0mm Projection	
Customer Client		Date	
Drawn By Dessiné Par BoxCad: Annie		Date 04/02/2015	
Material Matière		14 Ga H.R.P. & O. (1.7mm)	
Color Couleur		Asa-61 Grey	Finish Fini Smooth
Description		Detail Rev.	
5100ES 42" x 36" x 20" Body			
Part Number Numéro Pièce		Rev.	7
<b>5100ESFS423620B</b>		<b>0</b>	7

Qty	Part Number	Rev	Description
1	5100ESFS423620MF	0	880 MFT 20" Mounting Feet
1	STK-P-02400S	0	Powder Paint (Asa-61 Grey / Smooth)
8	STK-Q-16005	1	Stud M8 x 35 (No Paint Cap Required)
1	STK-Q-16080	0.1.1	M6 x 16mm Ground Stud
1	5100ESFS423620BT-P	0	5100ES 42" x 36" x 20" Body Part
1	5100ESFS423620T-P	0	5100ES 42" x 36" x 20" Body Part
1	5100ESFS423620B-P	0	5100ES 42" x 36" x 20" Body Part
Parts List			

This drawing is confidential and must not be reproduced or used without the consent of EXM

Ce dessin est confidentiel et ne doit pas être reproduit ou utilisé sans le consentement de EXM

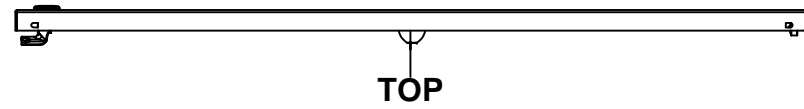

TOP

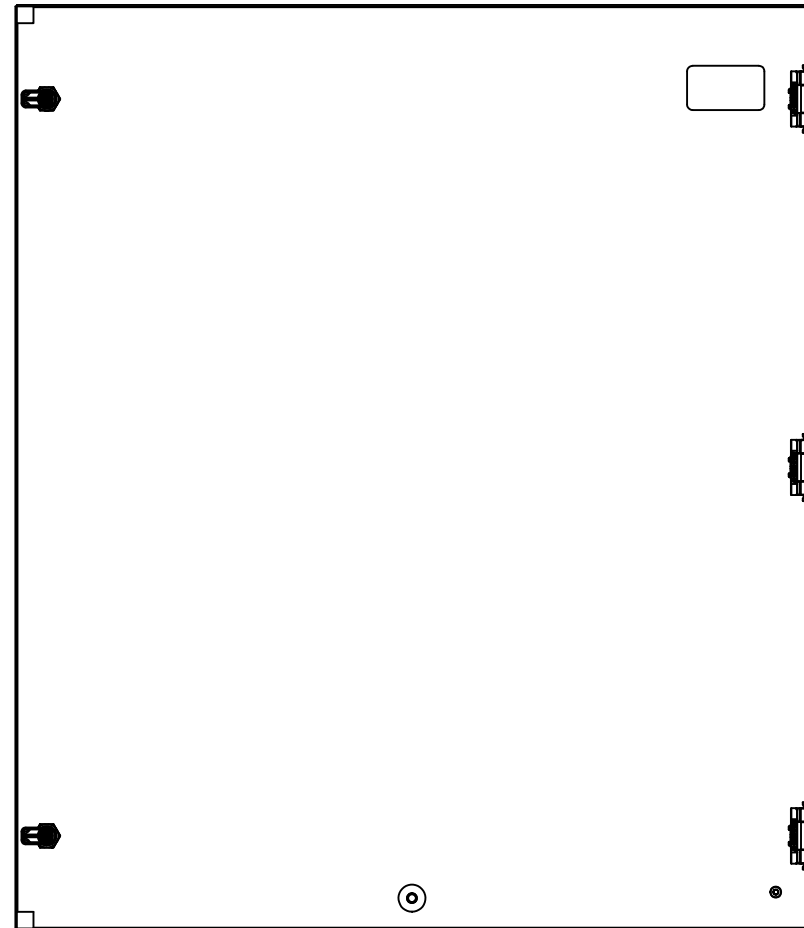

BACK



BOTTOM

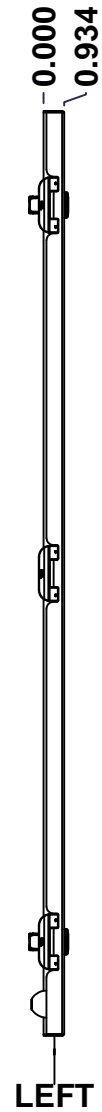

LEFT

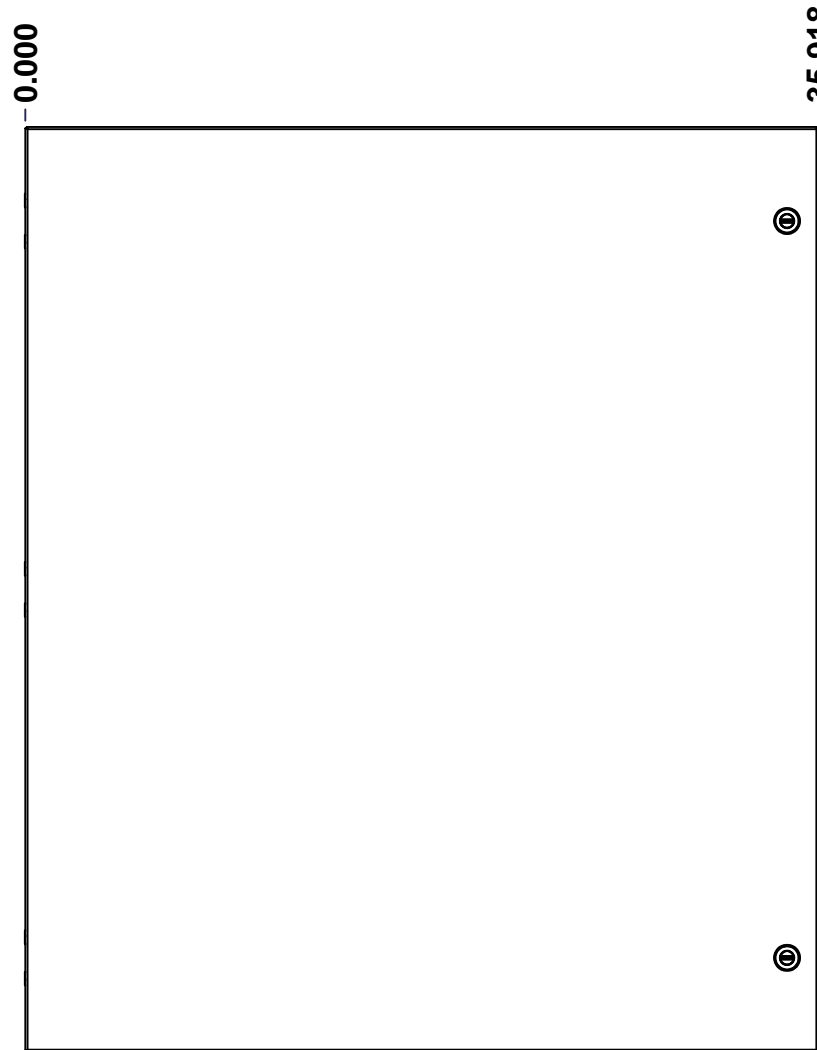

FRONT

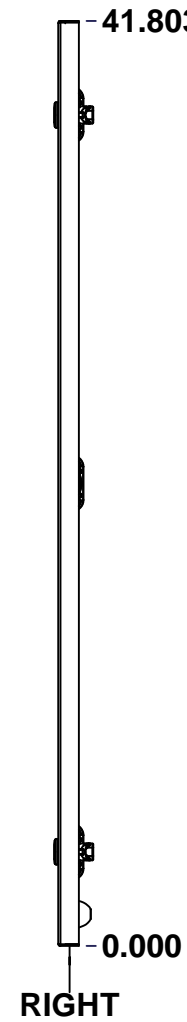

RIGHT

No.	Revisions	Date	By/Par

Isometric View

Tél: (450) 979-4373 Fax: (450) 979-4626 <a href="http://www.exmweb.com">www.exmweb.com</a>		Flatness Aplatissement Max 3.0mm Projection 
Customer Client	Date	Date
Drawn By Dessiné Par	BoxCad: Annie	Date 04/02/2015
Material Matière 14 Ga H.R.P. & O. (1.7mm)		
Color Couleur	Asa-61 Grey	Finish Fini Smooth
Description 5100ES 42" x 36" Cover		Detail Rev.
Part Number Numéro Pièce	Rev. 0	1 3

SEE BILL OF MATERIAL ON LAST PAGE

**5100ESFS423620C**

This drawing is confidential and must not be reproduced or used without the consent of EXM

Ce dessin est confidentiel et ne doit pas être reproduit ou utilisé sans le consentement de EXM

STANDARD FEATURES ARE NOT LISTED IN THIS HOLE TABLE			
HOLE TABLE - FRONT VIEW (CUSTOM FEATURE ONLY)			
CUT-OUT	XDIM	YDIM	DESCRIPTION
1	1.486	1.709	GND STUD M6 x 16mm (Inside)
2	17.959	1.435	STUD M6 x 18mm (Inside)

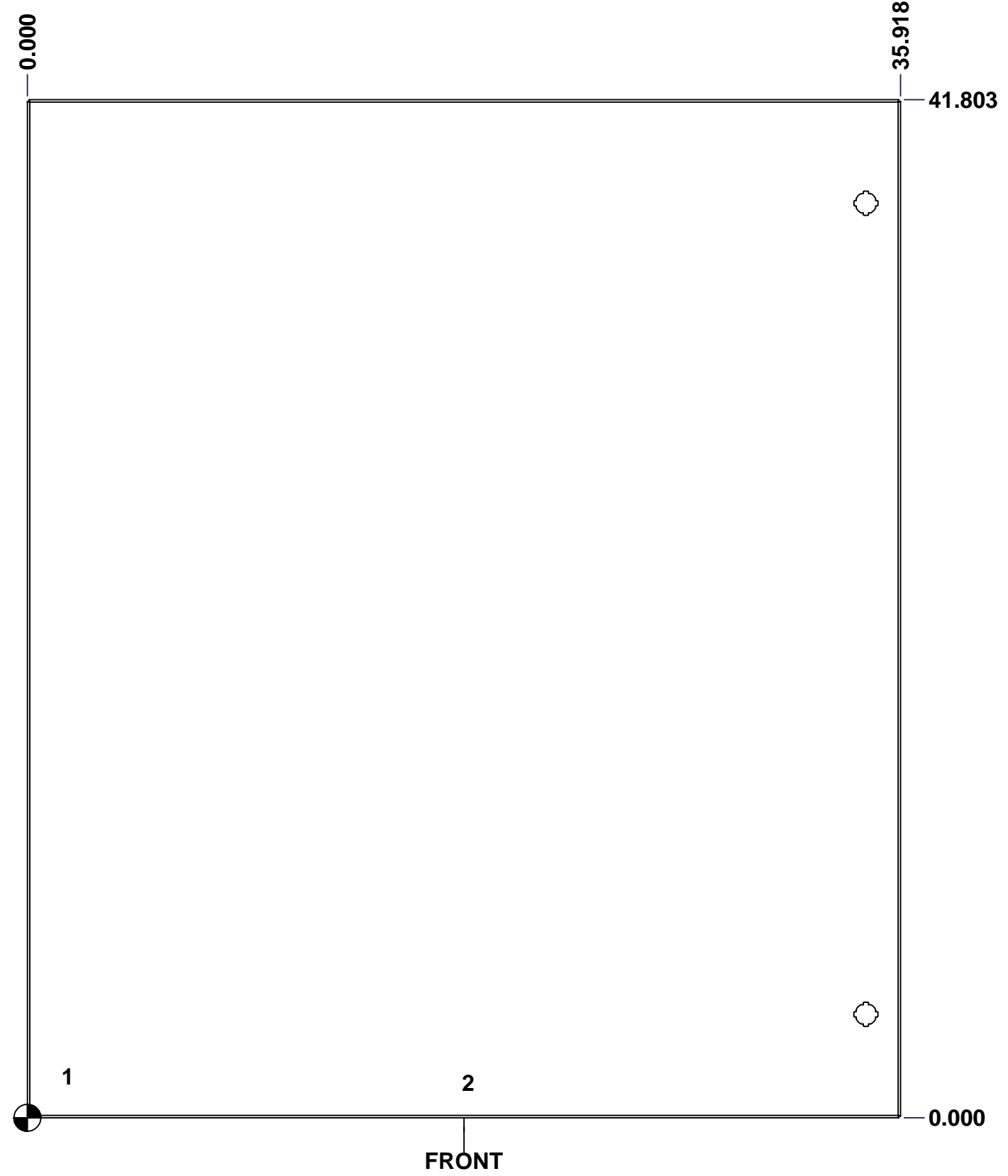

	Description	Status	
	5100ES 42" x 36" Cover	(NULL)	
	Part Number Numéro Pièce	Rev.	
	<b>5100ESFS423620C</b>	<b>0</b>	2 3



This drawing is confidential and must not be reproduced or used without the consent of EXM

Ce dessin est confidentiel et ne doit pas être reproduit ou utilisé sans le consentement de EXM

No.	Revisions	Date	By/Par

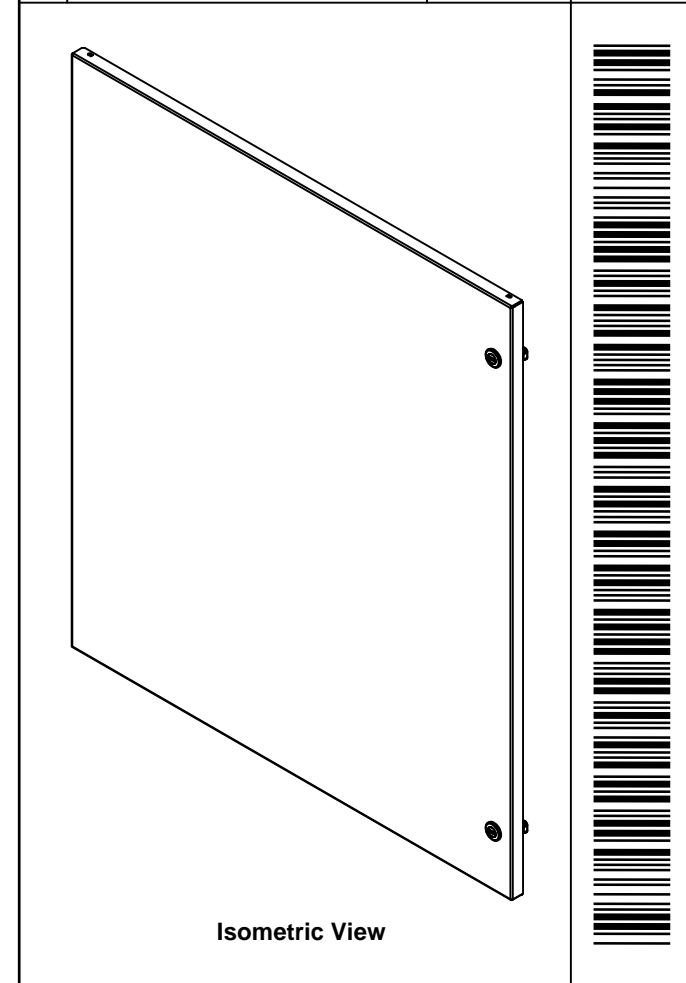

**EXM**  
www.exm.com

Tél: (450) 979-4373  
Fax: (450) 979-4626  
[www.exmweb.com](http://www.exmweb.com)

Flatness  
Aplatissement  
Max 3.0mm

Projection

Qty	Part Name	Rev	Description
1	STK-Q-46515	3	5412 ES Door Support with Brass Insert
1	STK-Q-16055	1	M6 x 18mm Stud (No Paint Cap Required)
1	STK-Q-16080	0.1.1	M6 x 16mm Ground Stud
1	STK-P-02400S	0	Powder Paint (Asa-61 Grey / Smooth)
1	STK-S-00100	0.1.1	3.5" x 2" Silver Milar Flexcon Sticker
2	STK-G-00350	1	Rubber Gasket 3/4" x 3/4" x 7/32"
1	5100ESFS423620C-P	0	5100ES 42" x 36" Cover Part
3	STK-K-09800	5	5412 ES Hinge with 2 Captive Hinge Pins
2	880 SCQ4-SL	0	5412 ES 1/4 Turn Lock
Parts List			

Customer Client

Drawn By / Dessiné Par: BoxCad: Annie

Material / Matière: 14 Ga H.R.P. & O. (1.7mm)

Color / Couleur: Asa-61 Grey

Finish / Fini: Smooth

Description: 5100ES 42" x 36" Cover

Part Number / Numéro Pièce: **5100ESFS423620C**

Date: 04/02/2015

Detail Rev. / Rev.:

0	3
0	3

This drawing is confidential and must not be reproduced or used without the consent of EXM

Ce dessin est confidentiel et ne doit pas être reproduit ou utilisé sans le consentement de EXM

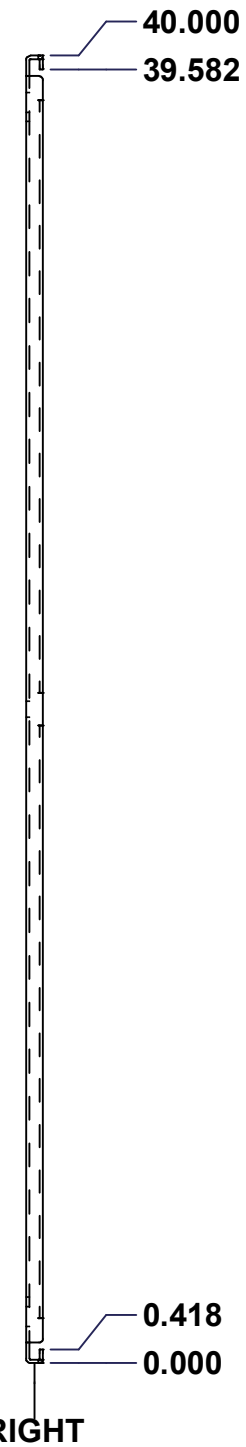
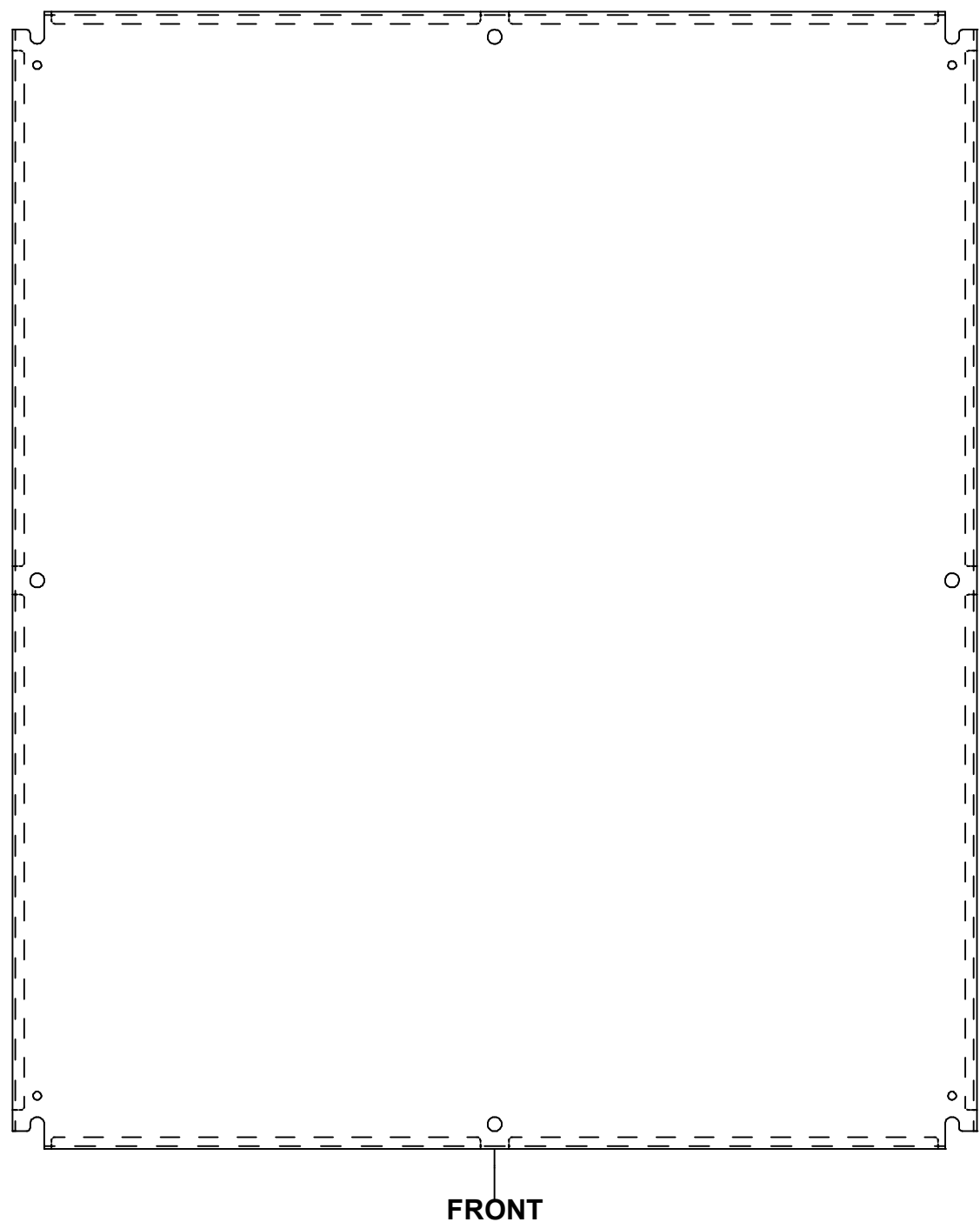
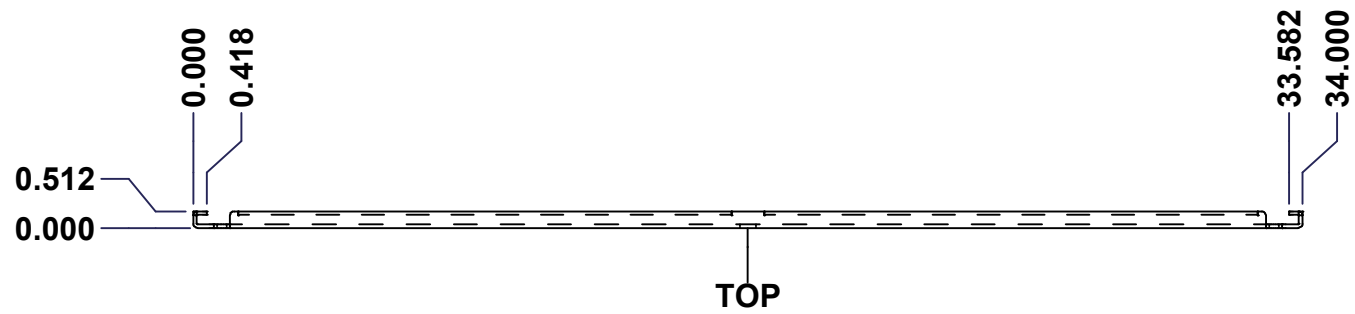

No.	Revisions	Date	By/Par

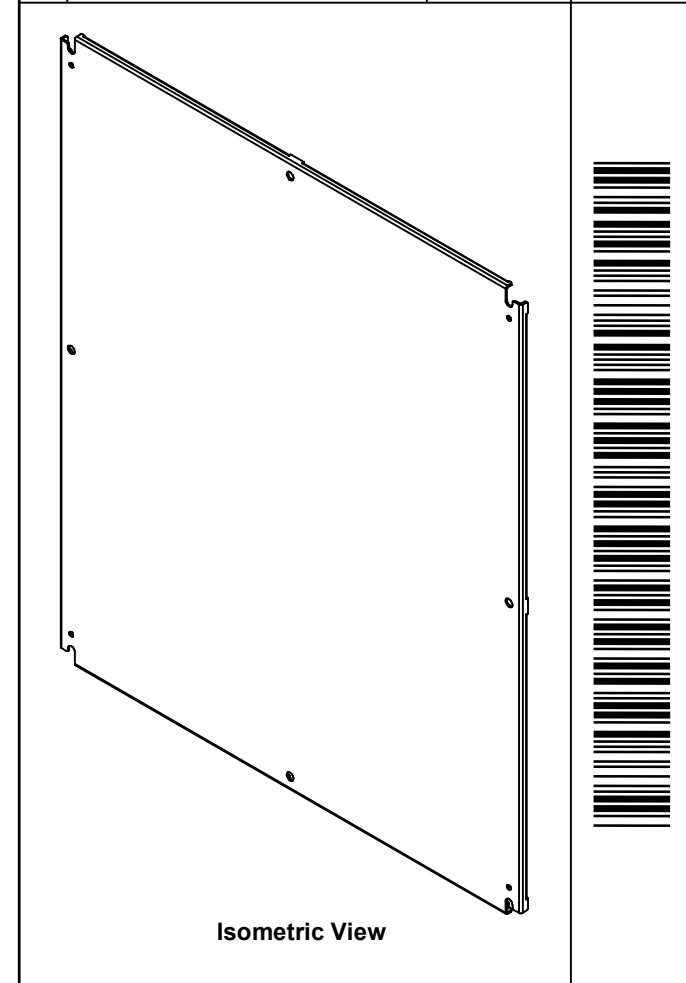

Tél: (450) 979-4373 Fax: (450) 979-4626 www.exmweb.com		Flatness Aplatissement Max 3.0mm Projection 
Customer Client	Date	
Drawn By Dessiné Par: BoxCad	Date: 1/23/2007	
Material Matière	See Part List	
Color Couleur	See Part List	Finish Fini: See Part List
Description: 881 SP - Inner Panel		Detail Rev.
Part Number Numéro Pièce: <b>881 SP4236</b>		Rev. 1/2

Qty	Part Number	Rev	Description	Material	Color	Finish
1	STK-P-02401S	0	Powder Paint (White / Smooth)	Polyester-Epoxy Hybrid	White RAL9003	Smooth
1	881 SP4236-P	0	881 SP - Inner Panel Part	12 Ga H.R.P. & O.	White	Smooth

Parts List

This drawing is confidential and must not be reproduced or used without the consent of EXM

Ce dessin est confidentiel et ne doit pas être reproduit ou utilisé sans le consentement de EXM

Table 1			FRONT VIEW
CUT-OUT	XDIM	YDIM	DESCRIPTION
1	17.000	0.875	MTG STUD HOLE (RND Ø0.500)
2	0.875	20.000	MTG STUD HOLE (RND Ø0.500)
3	33.125	20.000	MTG STUD HOLE (RND Ø0.500)
4	17.000	39.125	MTG STUD HOLE (RND Ø0.500)
5	0.875	1.875	GROUND HOLE (RND Ø0.290)
6	33.125	1.875	GROUND HOLE (RND Ø0.290)
7	0.875	38.125	GROUND HOLE (RND Ø0.290)
8	33.125	38.125	GROUND HOLE (RND Ø0.290)

All knockouts are actual size / Les disques défonçables sont grandeur réel

No.	Revisions	Date	By/Par

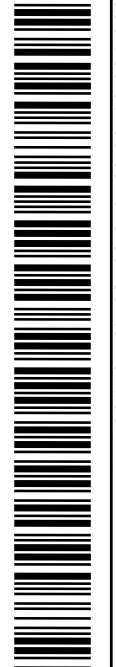
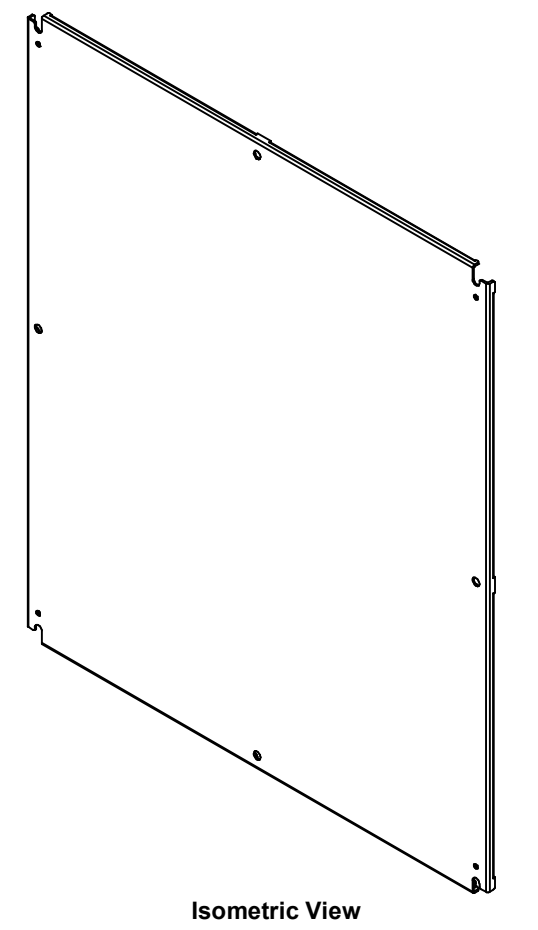
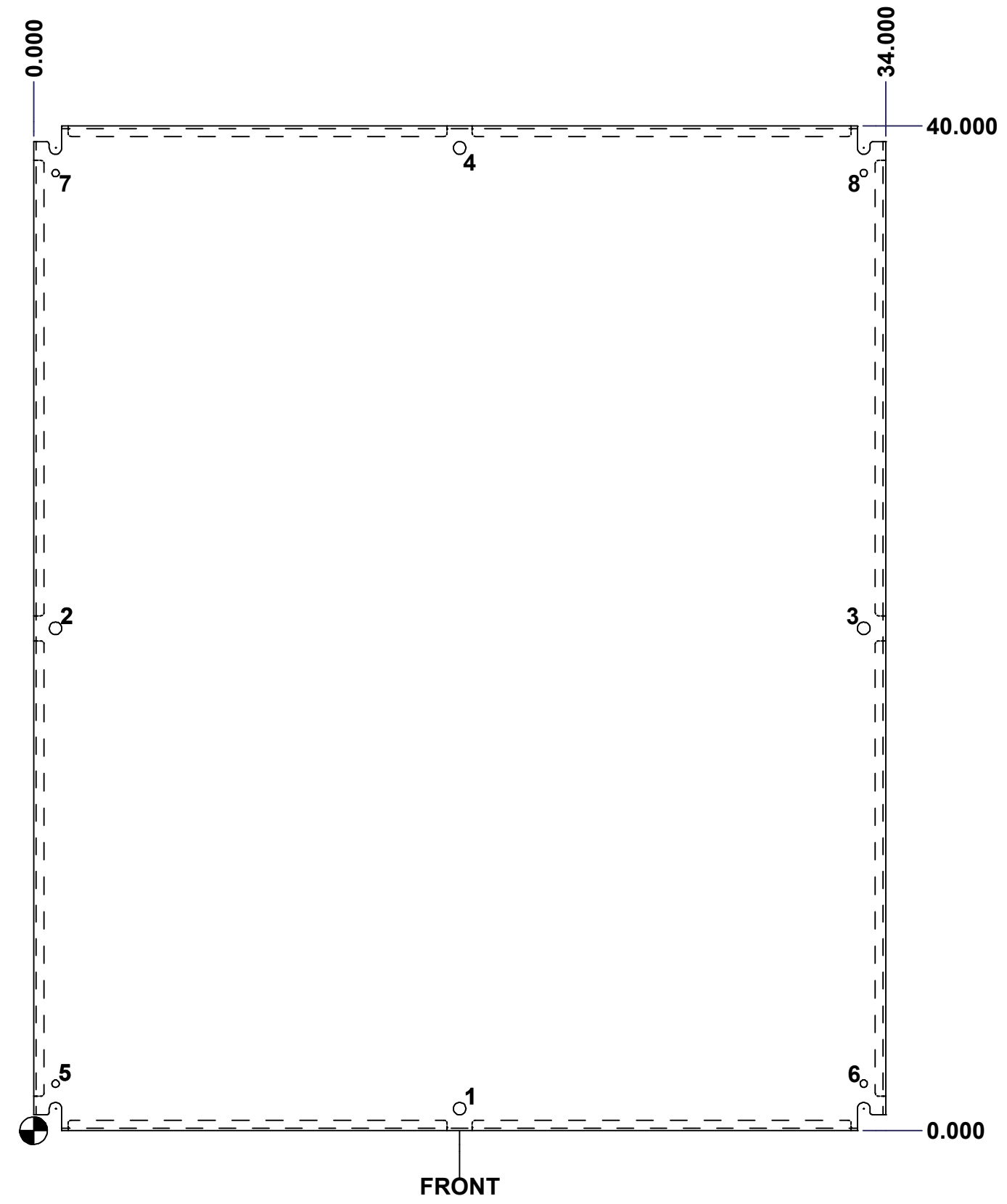

		Tél: (450) 979-4373 Fax: (450) 979-4626 www.exmweb.com		Flatness Aplatissement Max 3.0mm	
Customer Client		Date		Projection 	
Drawn By Dessiné Par BoxCad		Date 1/23/2007		Material Matière See Part List	
Color Couleur See Part List		Finish Fini See Part List		Description 881 SP - Inner Panel	
Part Number Numéro Pièce <b>881 SP4236</b>		Rev. <b>0</b>		Detail Rev. <b>2</b>	