

This drawing is confidential and must not be reproduced or used without the consent of EXM

Ce dessin est confidentiel et ne doit pas être reproduit ou utilisé sans le consentement de EXM

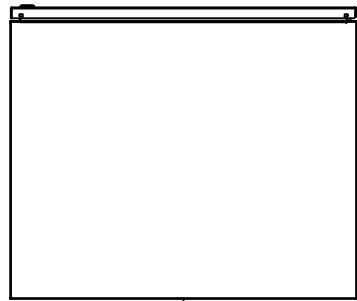

TOP

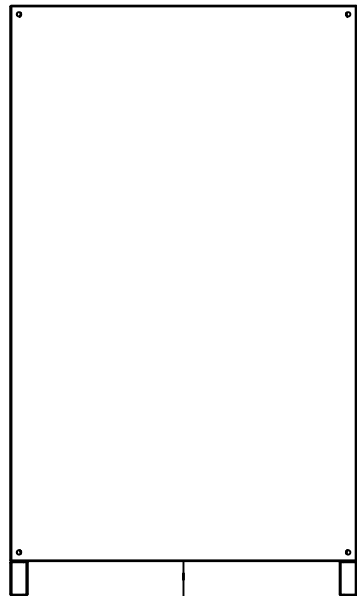

BACK

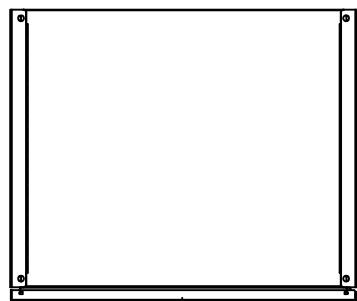

BOTTOM

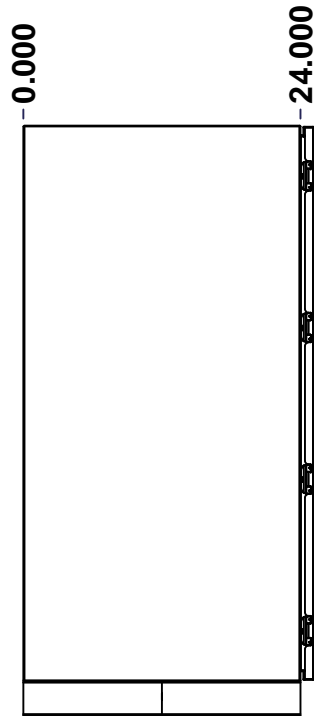

LEFT

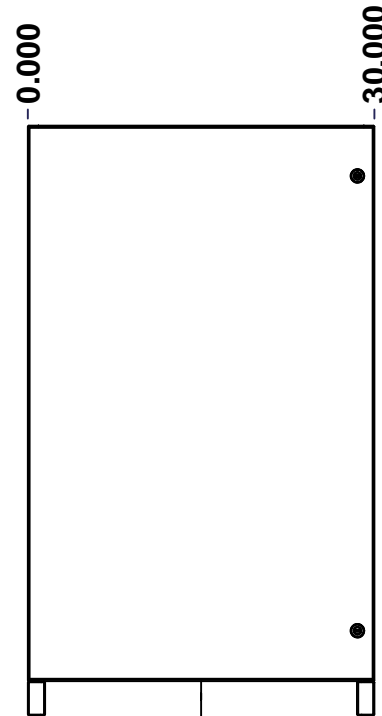

FRONT

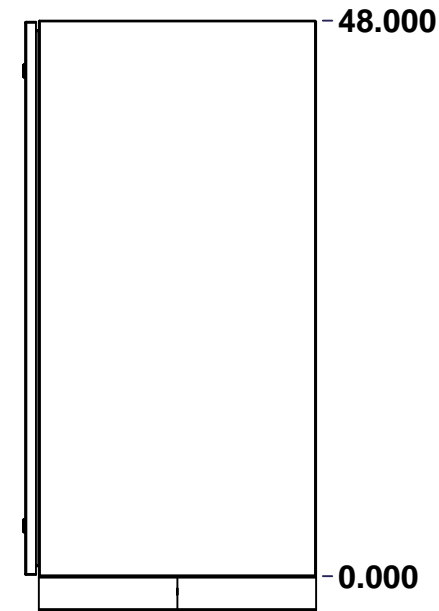

RIGHT

No.	Revisions	Date	By/Par

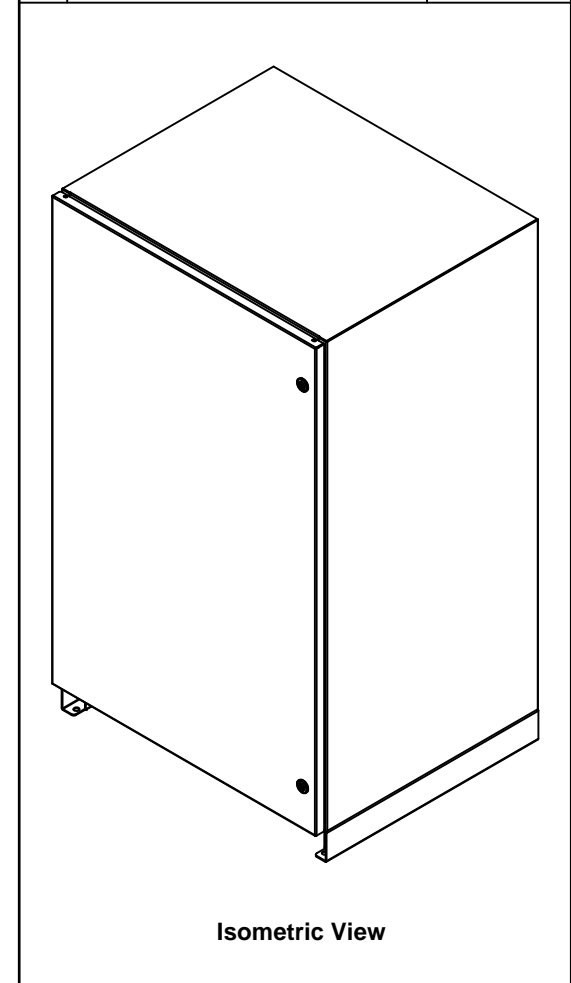

Isometric View

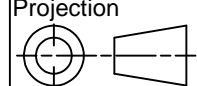

 Tél: (450) 979-4373 Fax: (450) 979-4626 www.exmweb.com		Flatness Aplatissement Max 3.0mm Projection 
Customer Client	Date	
Drawn By Dessiné Par	BoxCad: Annie	Date 04/02/2015
Material Matière	14 Ga H.R.P. & O. (1.7mm)	
Color Couleur	Asa-61 Grey	Finish Fini Smooth
Description	Detail Rev.	
5100ES 48" x 30" x 24" Assembly		
Part Number Numéro Pièce	Rev.	1 2
5100ESFS483024	0	

SEE BILL OF MATERIAL ON LAST PAGE

This drawing is confidential and must not be reproduced or used without the consent of EXM

Ce dessin est confidentiel et ne doit pas être reproduit ou utilisé sans le consentement de EXM

NOTE	
ITEM	DESCRIPTION
1	NEMA 1 Enclosure
2	C/W Standard ground studs on box and cover
3	W/O Standard door stiffener
4	C/W Standard inner panel (Sold seperately)
5	C/W Standard inner panel mounting studs
6	C/W Mounting feet sold seperately (Welded)

No.	Revisions	Date	By/Par

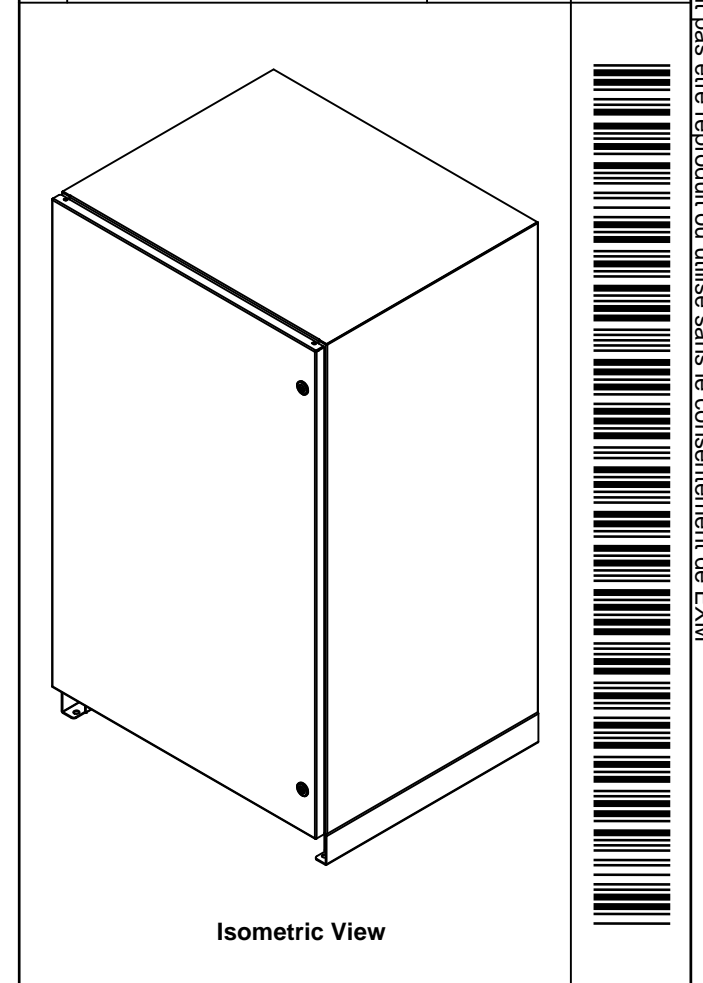

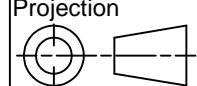
 Tél: (450) 979-4373 Fax: (450) 979-4626 www.exmweb.com		Flatness Aplatissement Max 3.0mm Projection 
Customer Client	Date	
Drawn By Dessiné Par	BoxCad: Annie	Date 04/02/2015
Material Matière	14 Ga H.R.P. & O. (1.7mm)	
Color Couleur	Asa-61 Grey	Finish Fini Smooth
Description	Detail Rev.	
5100ES 48" x 30" x 24" Assembly		
Part Number Numéro Pièce	Rev. 0	2
5100ESFS483024		2

Qty	Part Number	Rev	Description
1	STK-K-03000	1	5100 ES Accessory Kit
1	881 SP4830	0	881 SP - Inner Panel
1	5100ESFS483024C	0	5100ES 48" x 30" Cover
6	STK-Q-07310	2	Flange Lock Nut M8
1	5100ESFS483024B	0	5100ES 48" x 30" x 24" Body
6	STK-Q-07610	7	M8 Plastic Spacer 22.2mm
4	STK-Q-04050-07	5	M6 x 7mm Hexagon Socket Head Machine Screw with Nyseal
Parts List			

This drawing is confidential and must not be reproduced or used without the consent of EXM

Ce dessin est confidentiel et ne doit pas être reproduit ou utilisé sans le consentement de EXM

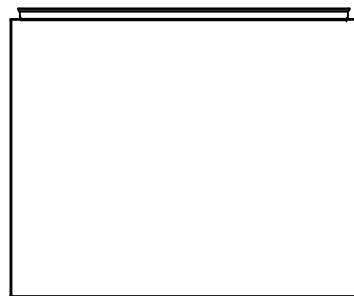

TOP



BACK

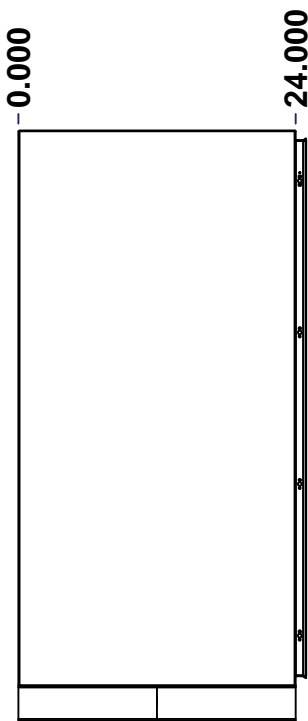

LEFT

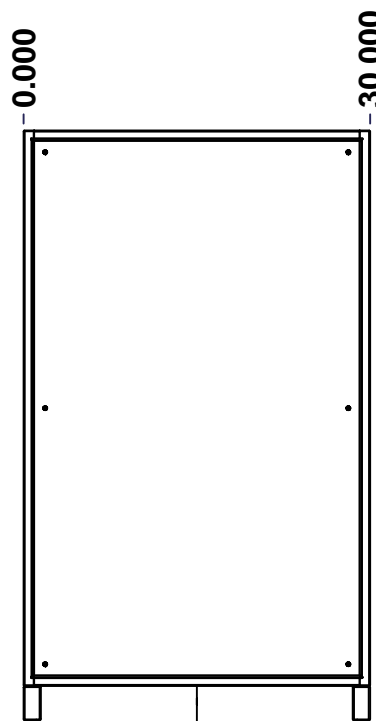

FRONT

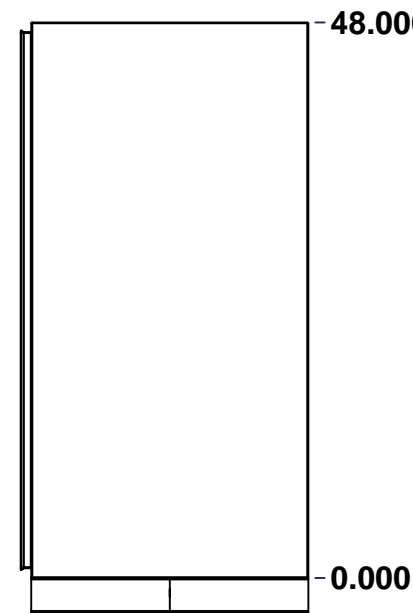

RIGHT



BOTTOM

No.	Revisions	Date	By/Par

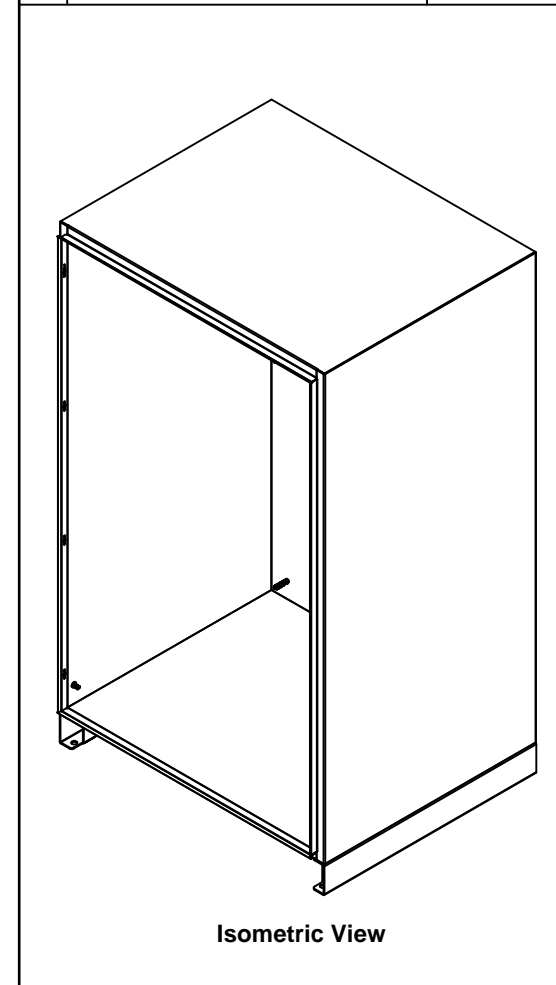

Isometric View

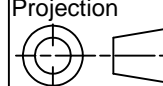

 Tél: (450) 979-4373 Fax: (450) 979-4626 www.exmweb.com		Flatness Aplatissement Max 3.0mm Projection 
Customer Client	Date	
Drawn By Dessiné Par	BoxCad: Annie	Date 04/02/2015
Material Matière	14 Ga H.R.P. & O. (1.7mm)	
Color Couleur	Asa-61 Grey	Finish Finis Smooth
Description	Detail Rev.	
5100ES 48" x 30" x 24" Body		
Part Number Numéro Pièce	Rev.	1 7
5100ESFS483024B	0	

SEE BILL OF MATERIAL ON LAST PAGE

This drawing is confidential and must not be reproduced or used without the consent of EXM

Ce dessin est confidentiel et ne doit pas être reproduit ou utilisé sans le consentement de EXM

STANDARD FEATURES ARE NOT LISTED IN THIS HOLE TABLE			
HOLE TABLE - LEFT VIEW (CUSTOM FEATURE ONLY)			
CUT-OUT	XDIM	YDIM	DESCRIPTION
1	22.500	1.932	GND STUD M6 x 16mm (Inside)

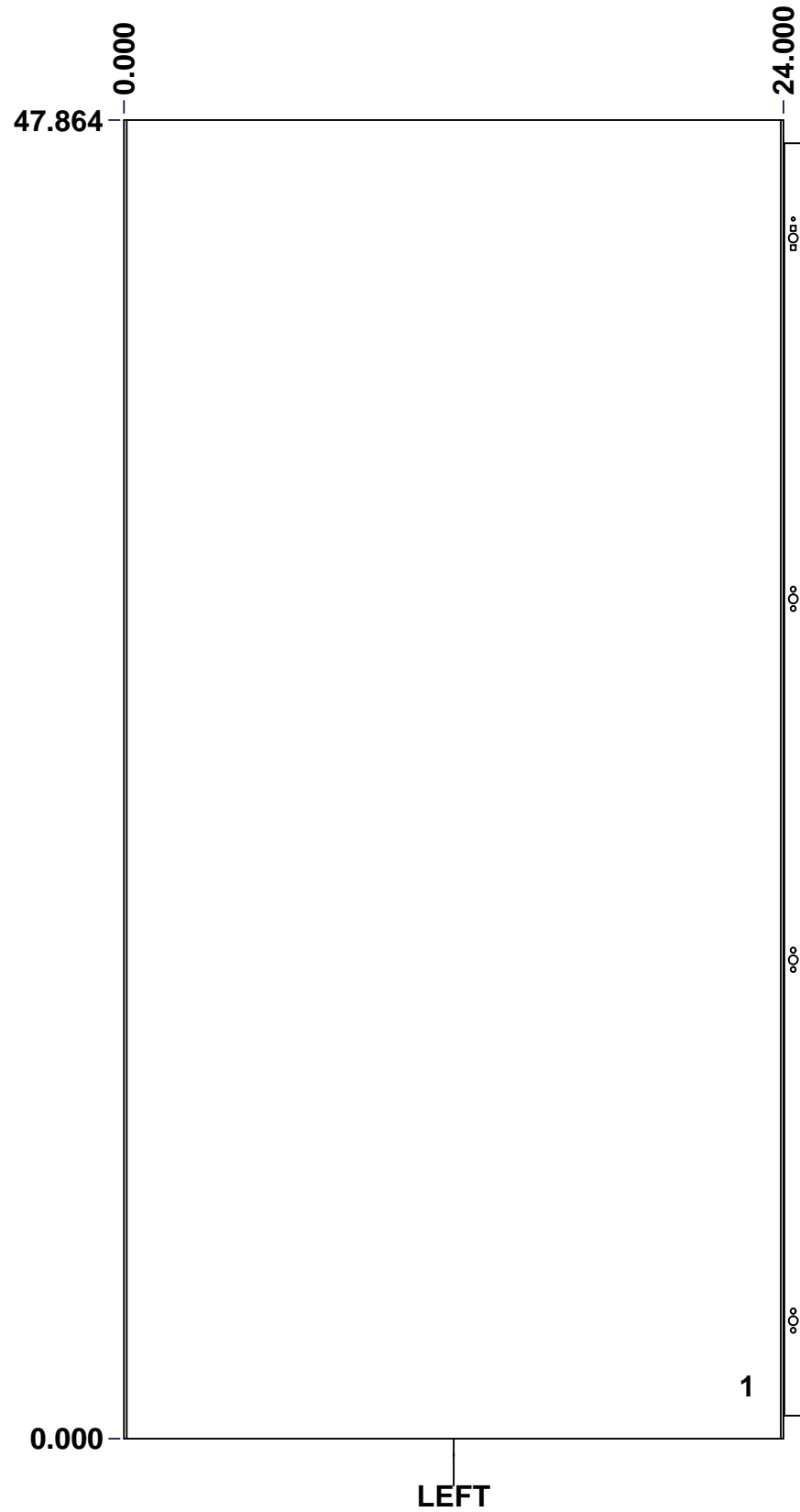

	Description	Status
	5100ES 48" x 30" x 24" Body	
	Part Number Numéro Pièce	Rev.
	5100ESFS483024B	0
		5 / 7

This drawing is confidential and must not be reproduced or used without the consent of EXM

Ce dessin est confidentiel et ne doit pas être reproduit ou utilisé sans le consentement de EXM

STANDARD FEATURES ARE NOT LISTED IN THIS HOLE TABLE

HOLE TABLE - BACK VIEW (CUSTOM FEATURE ONLY)

CUT-OUT	XDIM	YDIM	DESCRIPTION
1	1.875	1.807	IP STUD M8 x 35mm (Inside)
2	1.875	46.057	IP STUD M8 x 35mm (Inside)
3	28.125	46.057	IP STUD M8 x 35mm (Inside)
4	28.125	1.807	IP STUD M8 x 35mm (Inside)
5	1.875	23.932	IP STUD M8 x 35mm (Inside)
6	28.125	23.932	IP STUD M8 x 35mm (Inside)

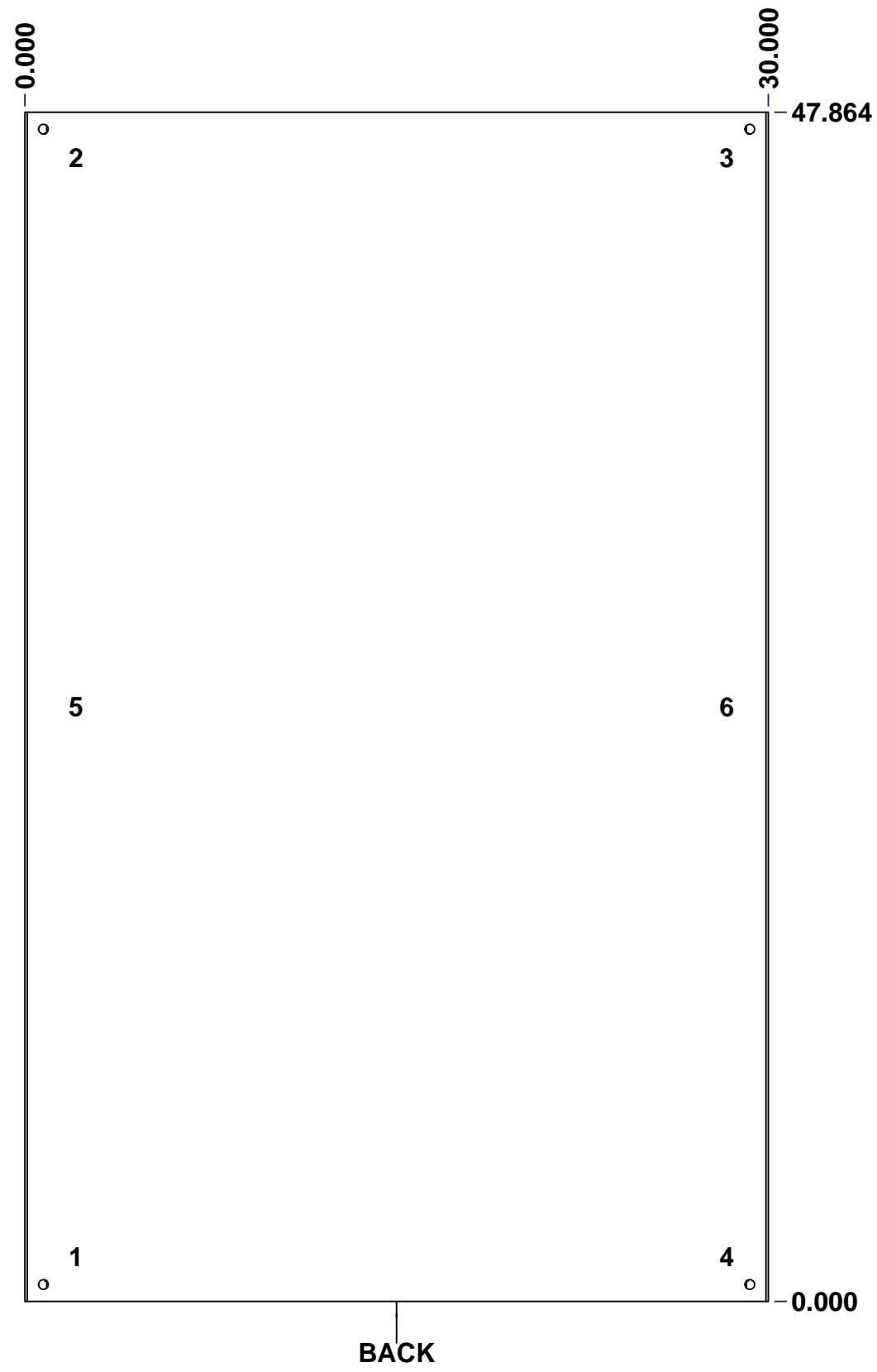

BACK

	Description	Status
	5100ES 48" x 30" x 24" Body	
	Part Number Numéro Pièce	Rev.
	5100ESFS483024B	0
		6 / 7

This drawing is confidential and must not be reproduced or used without the consent of EXM

Ce dessin est confidentiel et ne doit pas être reproduit ou utilisé sans le consentement de EXM

No.	Revisions	Date	By/Par

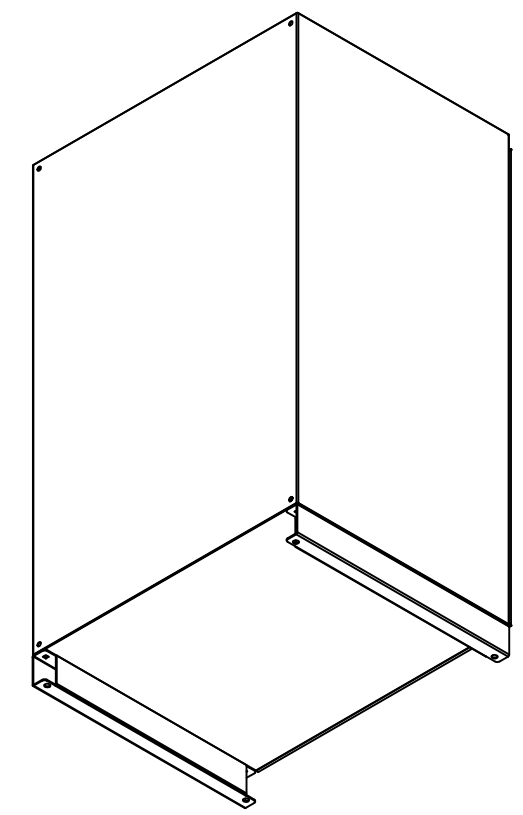

Isometric View

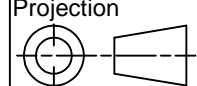

 Tél: (450) 979-4373 Fax: (450) 979-4626 www.exmweb.com		Flatness Aplatissement Max 3.0mm Projection 
Customer Client	Date	
Drawn By Dessiné Par	BoxCad: Annie	Date 04/02/2015
Material Matière	14 Ga H.R.P. & O. (1.7mm)	
Color Couleur	Asa-61 Grey	Finish Fini Smooth
Description	Detail Rev.	
5100ES 48" x 30" x 24" Body		
Part Number Numéro Pièce	Rev. 0	7 / 7
5100ESFS483024B		

Qty	Part Number	Rev	Description
1	5100ESFS483024MF	0	880 MFT 24" Mounting Feet
1	STK-P-02400S	0	Powder Paint (Asa-61 Grey / Smooth)
6	STK-Q-16005	1	Stud M8 x 35 (No Paint Cap Required)
1	STK-Q-16080	0.1.1	M6 x 16mm Ground Stud
1	5100ESFS483024BT-P	0	5100ES 48" x 30" x 24" Body Part
1	5100ESFS483024T-P	0	5100ES 48" x 30" x 24" Body Part
1	5100ESFS483024B-P	0	5100ES 48" x 30" x 24" Body Part
Parts List			

This drawing is confidential and must not be reproduced or used without the consent of EXM

Ce dessin est confidentiel et ne doit pas être reproduit ou utilisé sans le consentement de EXM

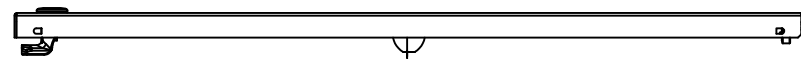

TOP

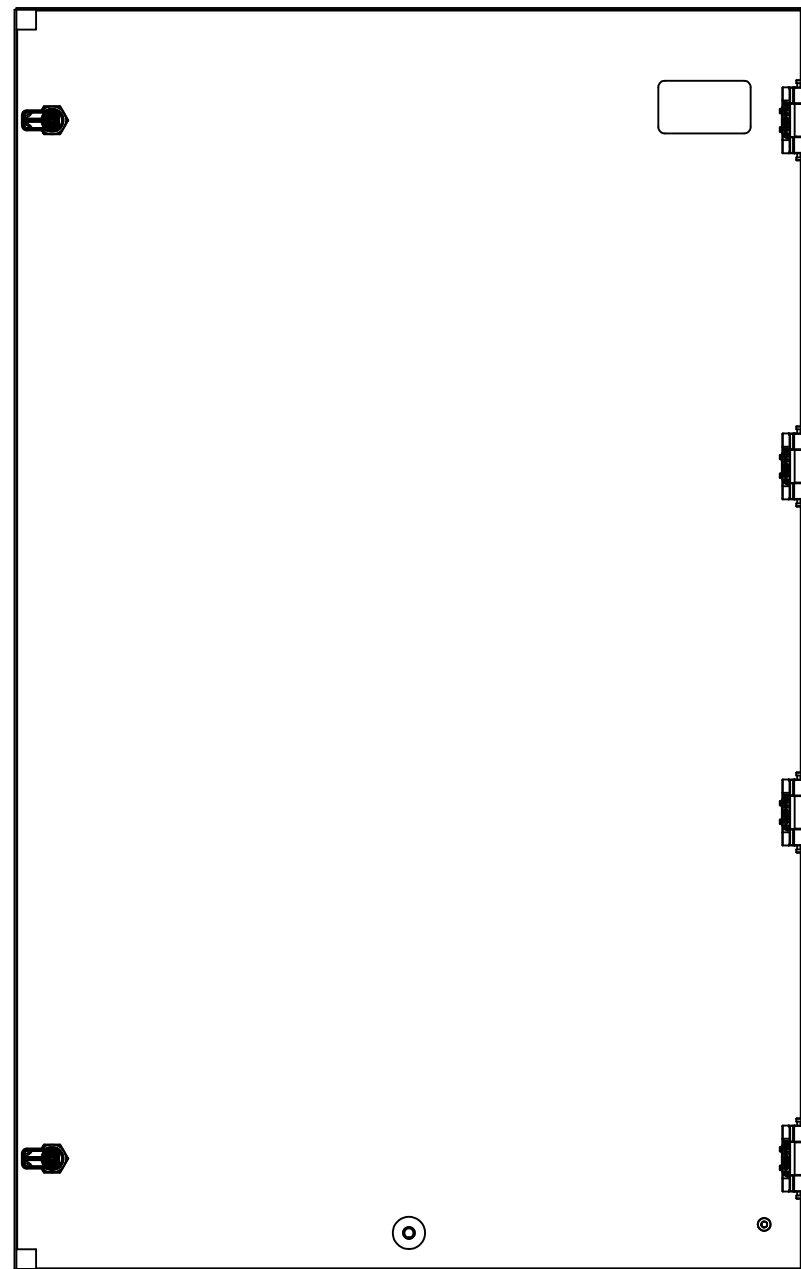

BACK



BOTTOM

0.000
0.934

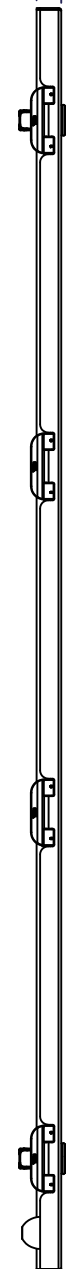

LEFT

0.000

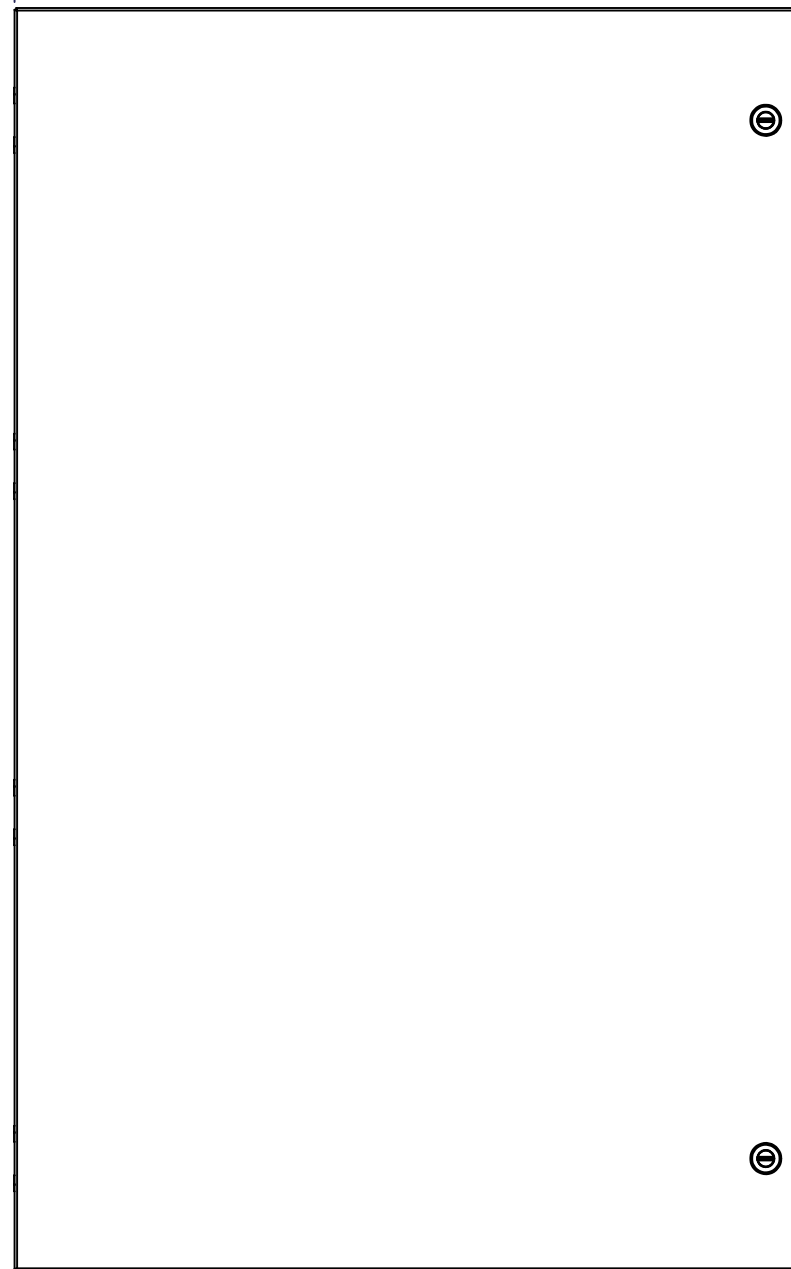

FRONT

29.918

47.803

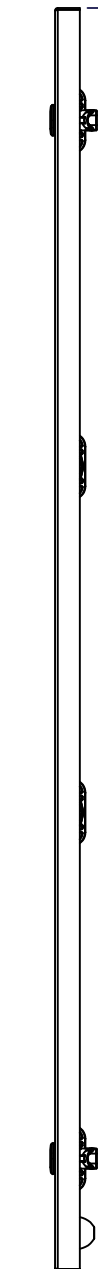

RIGHT

0.000

No.	Revisions	Date	By/Par

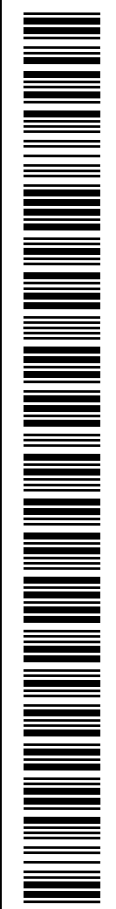
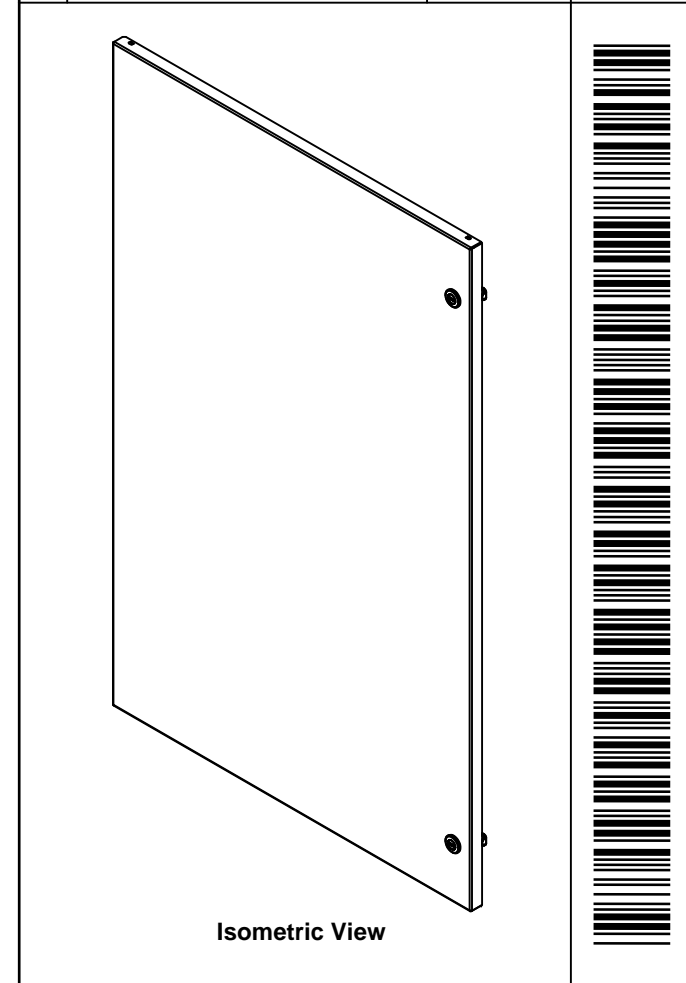

 Tél: (450) 979-4373 Fax: (450) 979-4626 www.exmweb.com		Flatness Aplatissement	
		Max 3.0mm	
Customer Client		Date	
Drawn By Dessiné Par BoxCad: Annie		Date 04/02/2015	
Material Matière		14 Ga H.R.P. & O. (1.7mm)	
Color Couleur Asa-61 Grey		Finish Fini Smooth	
Description		Detail Rev.	
5100ES 48" x 30" Cover			
Part Number Numéro Pièce		Rev.	1
5100ESFS483024C		0	3

SEE BILL OF MATERIAL ON LAST PAGE

This drawing is confidential and must not be reproduced or used without the consent of EXM

Ce dessin est confidentiel et ne doit pas être reproduit ou utilisé sans le consentement de EXM

STANDARD FEATURES ARE NOT LISTED IN THIS HOLE TABLE			
HOLE TABLE - FRONT VIEW (CUSTOM FEATURE ONLY)			
CUT-OUT	XDIM	YDIM	DESCRIPTION
1	1.486	1.756	GND STUD M6 x 16mm (Inside)
2	14.959	1.435	STUD M6 x 18mm (Inside)

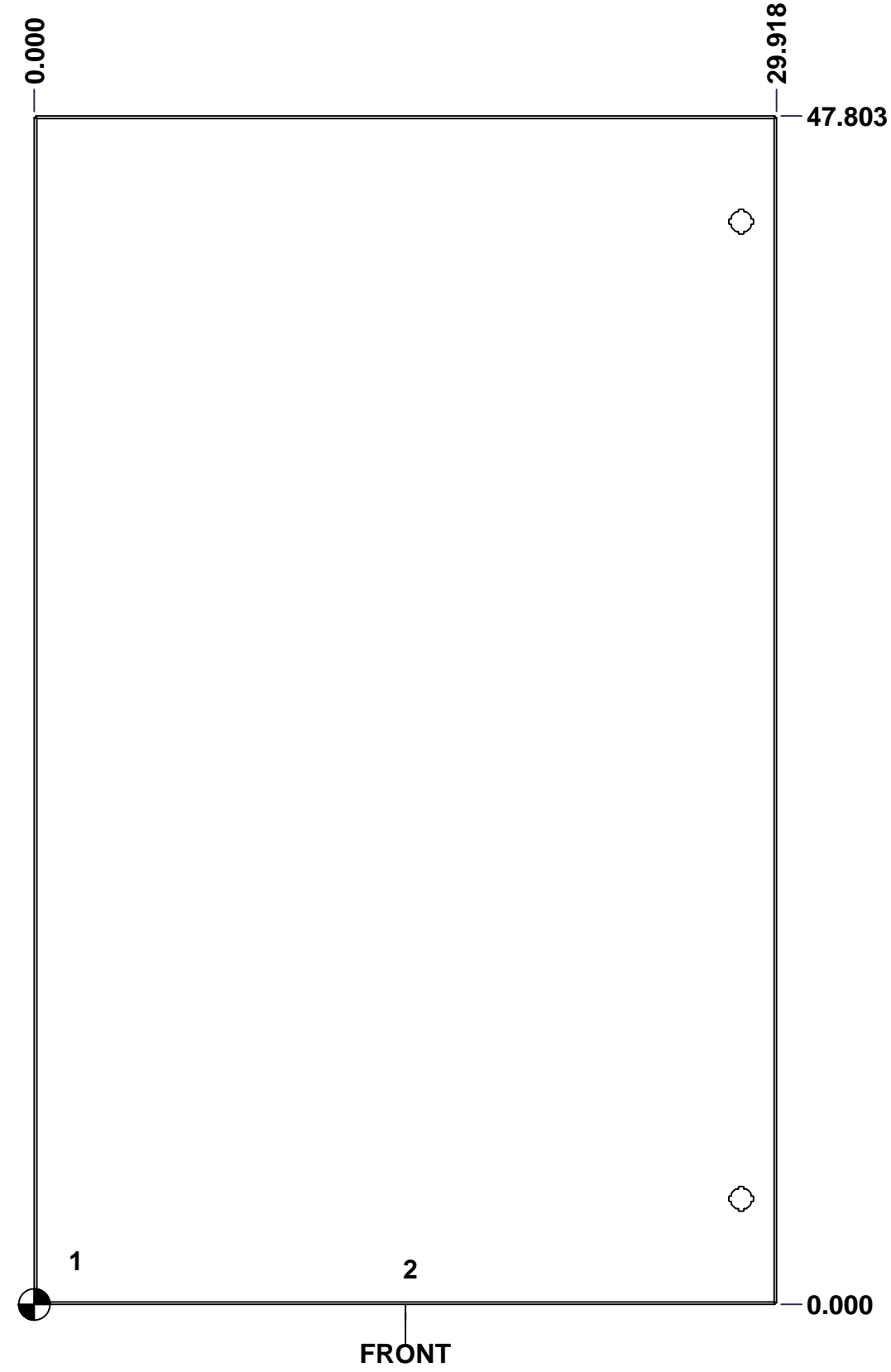

	Description	Status
	5100ES 48" x 30" Cover	(NULL)
	Part Number Numéro Pièce	Rev.
	5100ESFS483024C	0
		2
		3

This drawing is confidential and must not be reproduced or used without the consent of EXM

Ce dessin est confidentiel et ne doit pas être reproduit ou utilisé sans le consentement de EXM

No.	Revisions	Date	By/Par

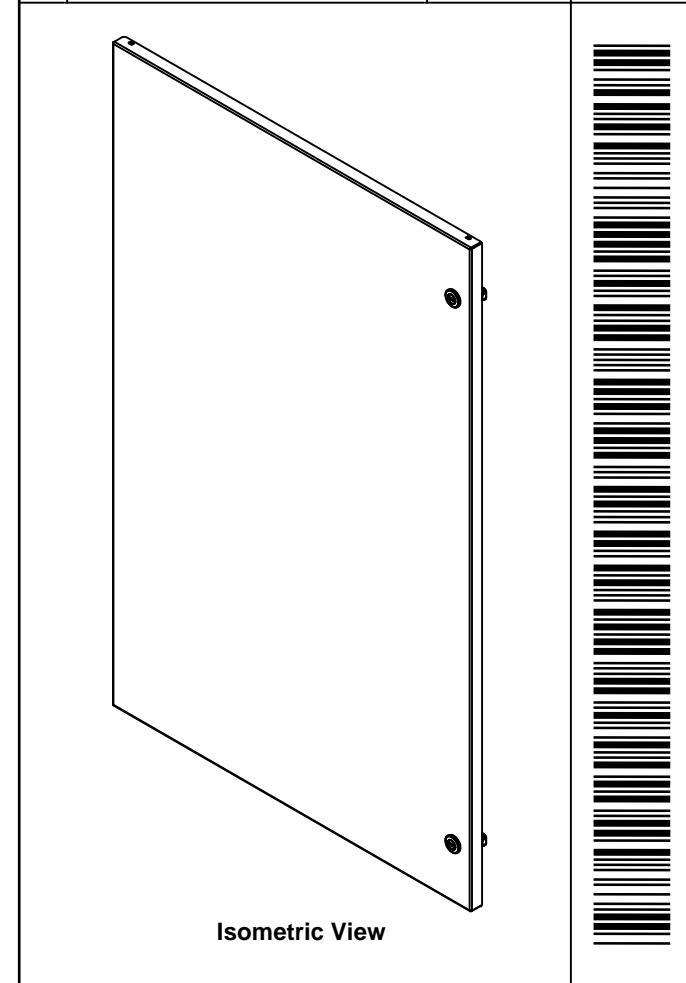

Qty	Part Name	Rev	Description
1	STK-P-02400S	0	Powder Paint (Asa-61 Grey / Smooth)
1	STK-Q-16055	1	M6 x 18mm Stud (No Paint Cap Required)
1	STK-Q-16080	0.1.1	M6 x 16mm Ground Stud
1	STK-S-00100	0.1.1	3.5" x 2" Silver Milar Flexcon Sticker
1	STK-Q-46515	3	5412 ES Door Support with Brass Insert
2	STK-G-00350	1	Rubber Gasket 3/4" x 3/4" x 7/32"
1	5100ESFS483024C-P	0	5100ES 48" x 30" Cover Part
4	STK-K-09800	5	5412 ES Hinge with 2 Captive Hinge Pins
2	880 SCQ4-SL	0	5412 ES 1/4 Turn Lock
Parts List			

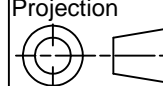
 Tél: (450) 979-4373 Fax: (450) 979-4626 www.exmweb.com		Flatness Aplatissement Max 3.0mm Projection 
Customer Client	Date	
Drawn By Dessiné Par	BoxCad: Annie	Date 04/02/2015
Material Matière	14 Ga H.R.P. & O. (1.7mm)	
Color Couleur	Asa-61 Grey	Finish Fini Smooth
Description		Detail Rev.
5100ES 48" x 30" Cover		
Part Number Numéro Pièce	Rev. 3	3
5100ESFS483024C	0	

This drawing is confidential and must not be reproduced or used without the consent of EXM

Ce dessin est confidentiel et ne doit pas être reproduit ou utilisé sans le consentement de EXM

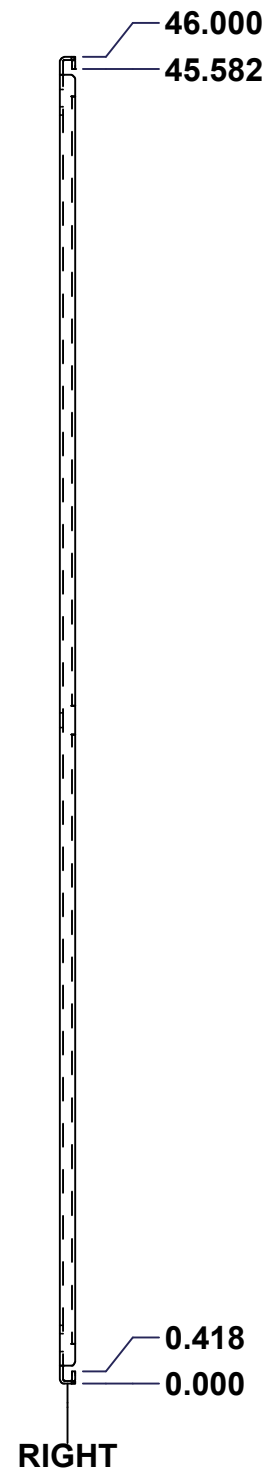
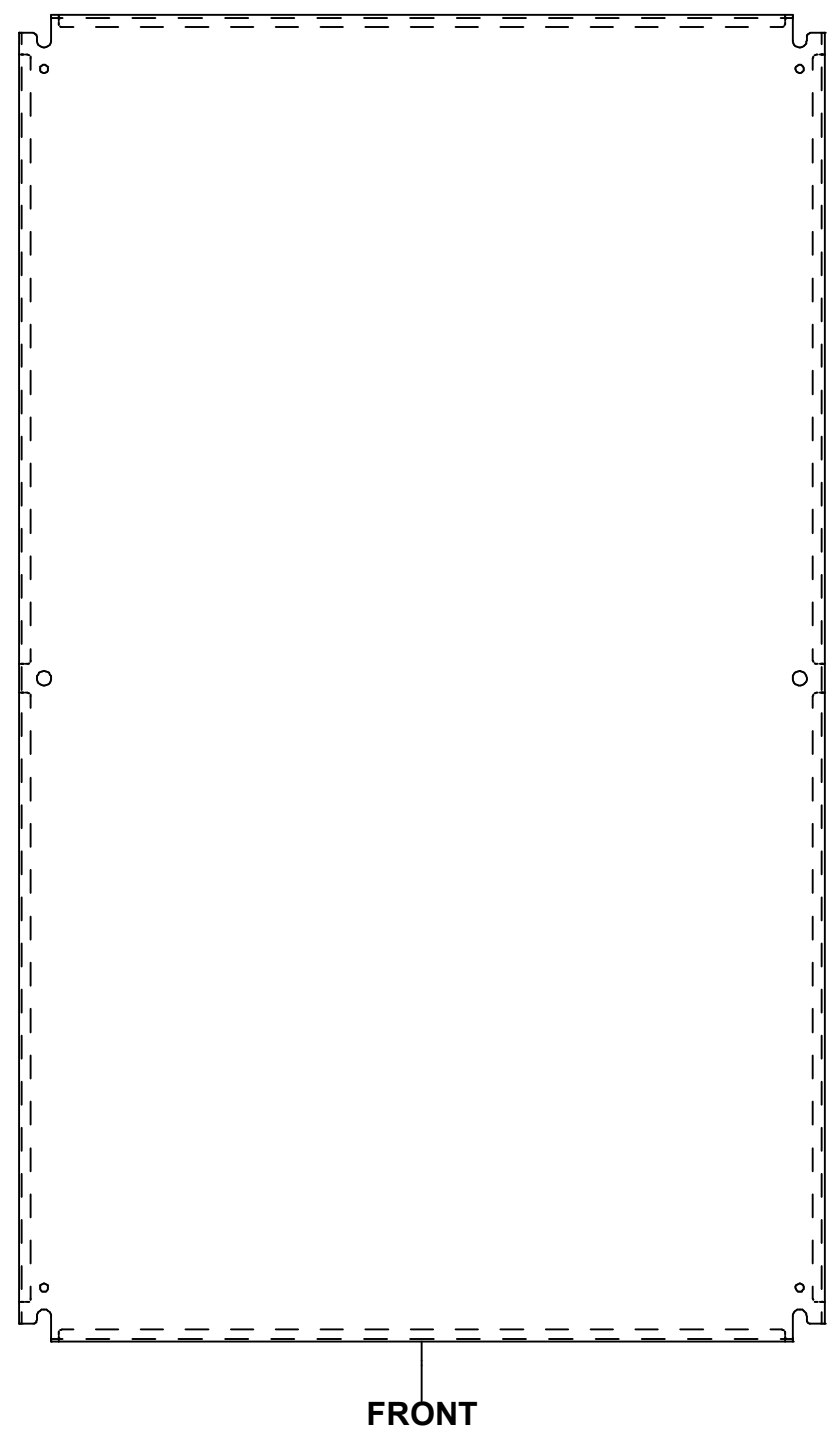
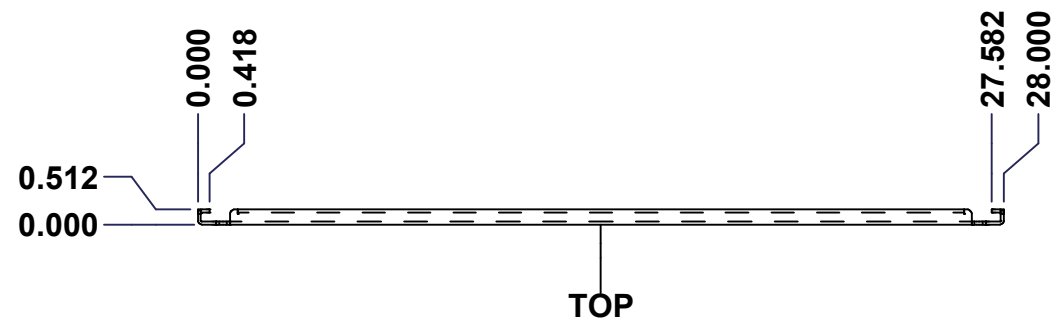

No.	Revisions	Date	By/Par

Isometric View

Tél: (450) 979-4373 Fax: (450) 979-4626 www.exmweb.com		Flatness Aplatissement	
		Max 3.0mm	
Customer Client		Date	
Drawn By Dessiné Par: BoxCad		Date: 1/23/2007	
Material Matière		See Part List	
Color Couleur	See Part List	Finish Fini	See Part List
Description		Detail Rev.	
881 SP - Inner Panel			
Part Number Numéro Pièce		Rev.	1
881 SP4830		0	2

Qty	Part Number	Rev	Description	Material	Color	Finish
1	STK-P-02401S	0	Powder Paint (White / Smooth)	Polyester-Epoxy Hybrid	White RAL9003	Smooth
1	881 SP4830-P	0	881 SP - Inner Panel Part	12 Ga H.R.P. & O.	White	Smooth

Parts List

This drawing is confidential and must not be reproduced or used without the consent of EXM

Ce dessin est confidentiel et ne doit pas être reproduit ou utilisé sans le consentement de EXM

Table 1			FRONT VIEW
CUT-OUT	XDIM	YDIM	DESCRIPTION
1	0.875	1.875	GROUND HOLE (RND Ø0.290)
2	27.125	1.875	GROUND HOLE (RND Ø0.290)
3	0.875	44.125	GROUND HOLE (RND Ø0.290)
4	27.125	44.125	GROUND HOLE (RND Ø0.290)
5	0.875	23.000	MTG STUD HOLE (RND Ø0.500)
6	27.125	23.000	MTG STUD HOLE (RND Ø0.500)

All knockouts are actual size / Les disques défonçables sont grandeur réel

No.	Revisions	Date	By/Par

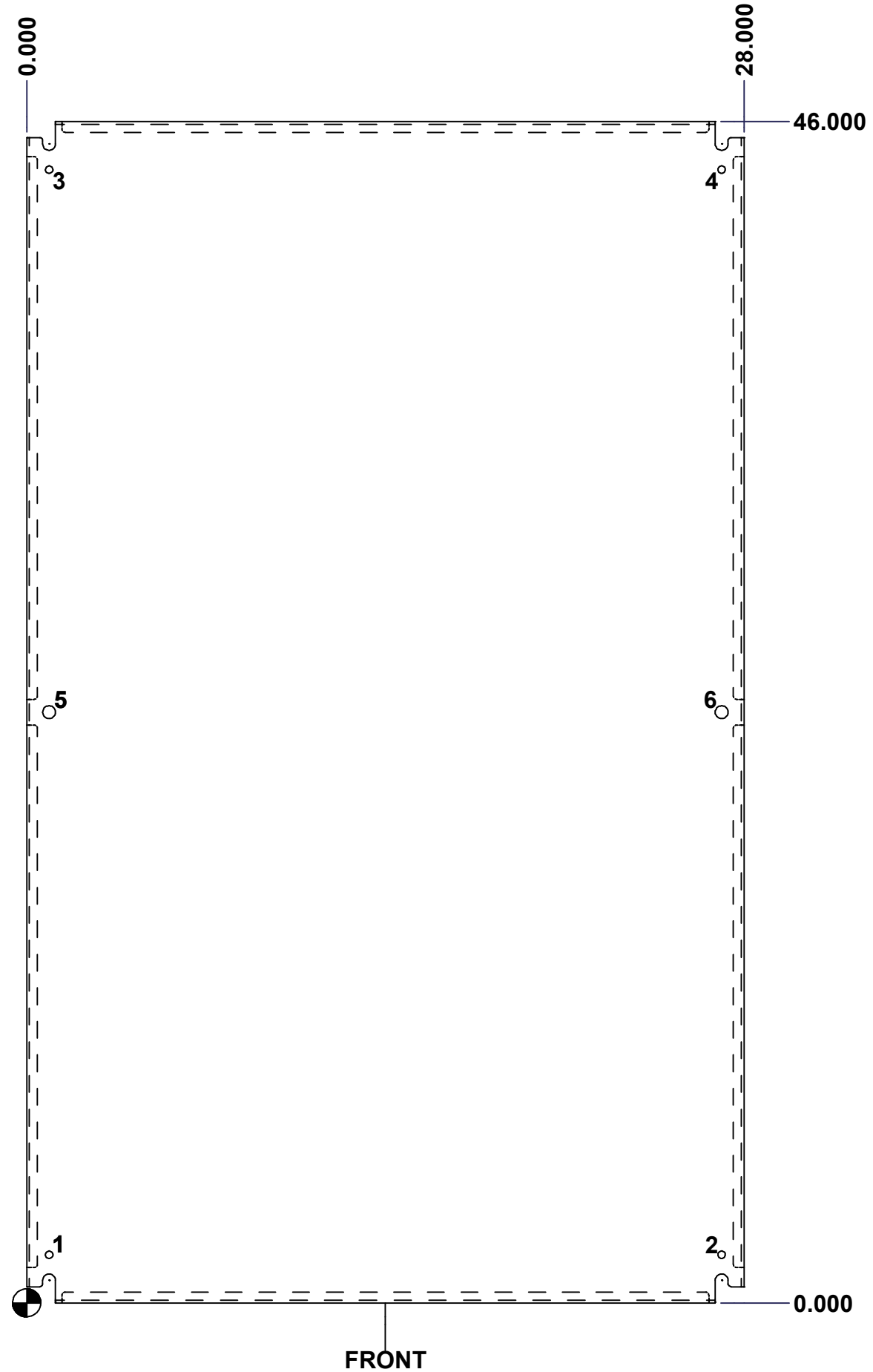

Isometric View

<p>Tél: (450) 979-4373 Fax: (450) 979-4626 www.exmweb.com</p>		Flatness Aplatissement
		Max 3.0mm
Projection		
Customer Client	Date	
Drawn By Dessiné Par	BoxCad	Date 1/23/2007
Material Matière	See Part List	
Color Couleur	See Part List	Finish Fini See Part List
Description	Detail Rev.	
881 SP - Inner Panel		
Part Number Numéro Pièce	Rev.	2
881 SP4830		0