

This drawing is confidential and must not be reproduced or used without the consent of EXM

Ce dessin est confidentiel et ne doit pas être reproduit ou utilisé sans le consentement de EXM

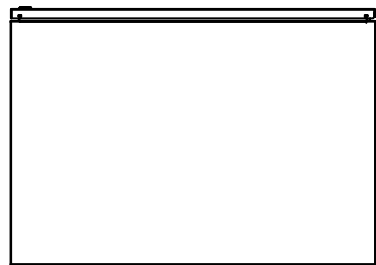

TOP

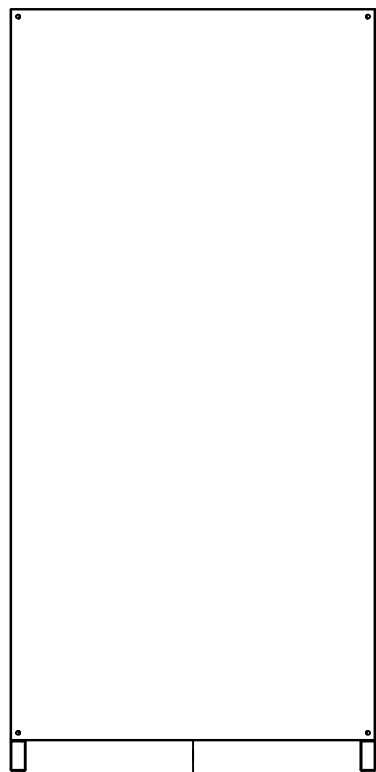

BACK

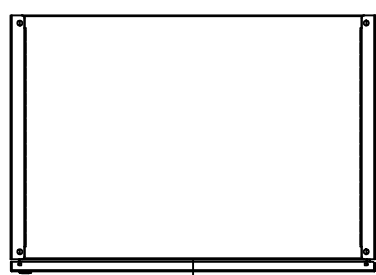

BOTTOM

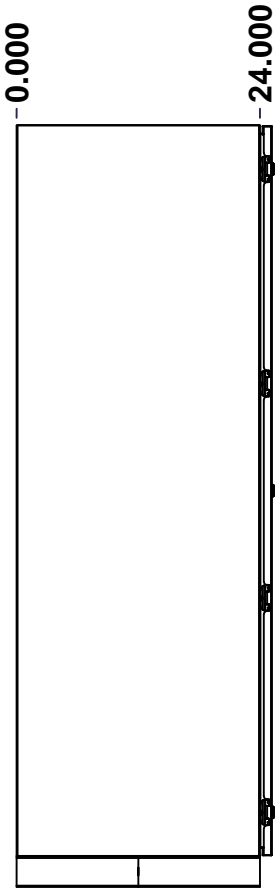

LEFT

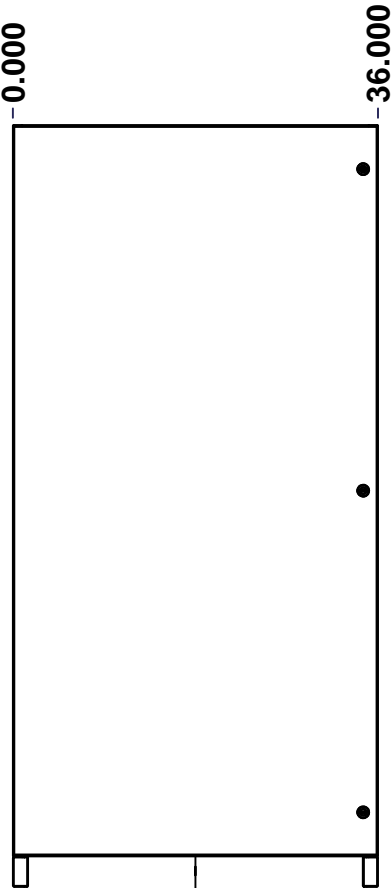

FRONT

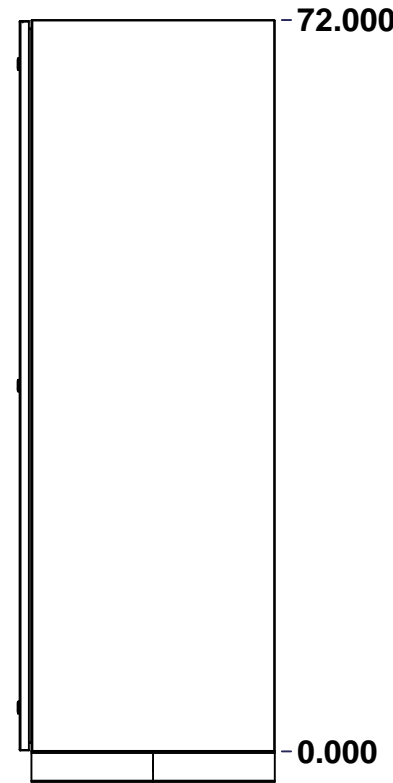

RIGHT

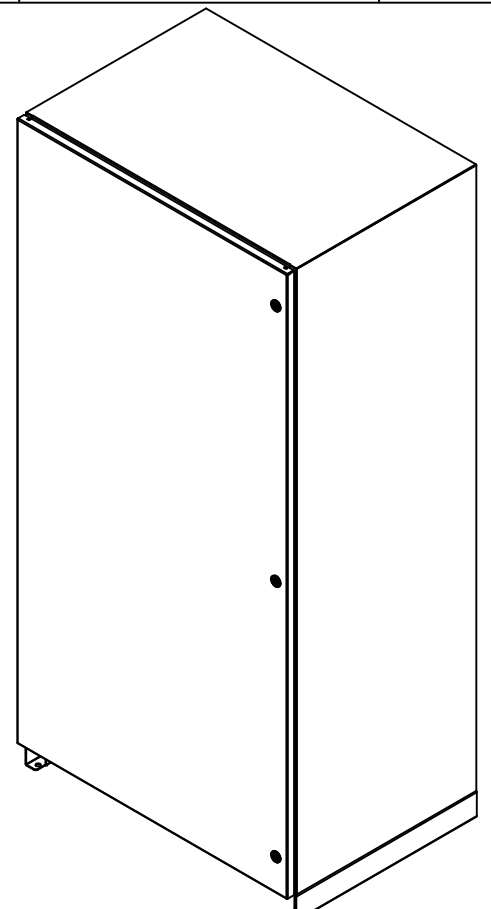

Isometric View

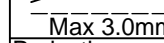
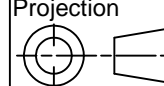

| No. | Revisions | Date | By/Par |
|-----|-----------|------|--------|
| | | | |
| | | | |
| | | | |
| | | | |
| | | | |

| | | |
|--|---------------------------|---|
|  Tél: (450) 979-4373 Fax: (450) 979-4626 www.exmweb.com | | Flatness Aplatissement  Max 3.0mm Projection  |
| Customer Client | Date | |
| Drawn By Dessiné Par | BoxCad: Annie | Date 04/02/2015 |
| Material Matière | 14 Ga H.R.P. & O. (1.7mm) | |
| Color Couleur | Asa-61 Grey | Finish Finis Smooth |
| Description | Detail Rev. | |
| 5100ES 72" x 36" x 24" Assembly | | |
| Part Number Numéro Pièce | Rev. 0 | 1 2 |
| 5100ESFS723624 | | |

SEE BILL OF MATERIAL ON LAST PAGE

This drawing is confidential and must not be reproduced or used without the consent of EXM

Ce dessin est confidentiel et ne doit pas être reproduit ou utilisé sans le consentement de EXM

| NOTE | |
|------|--|
| ITEM | DESCRIPTION |
| 1 | NEMA 1 Enclosure |
| 2 | C/W Standard ground studs on box and cover |
| 3 | W/O Standard door stiffener |
| 4 | C/W Standard inner panel (Sold seperately) |
| 5 | C/W Standard inner panel mounting studs |
| 6 | C/W Mounting feet sold seperately (Welded) |

| No. | Revisions | Date | By/Par |
|-----|-----------|------|--------|
| | | | |
| | | | |
| | | | |
| | | | |
| | | | |
| | | | |

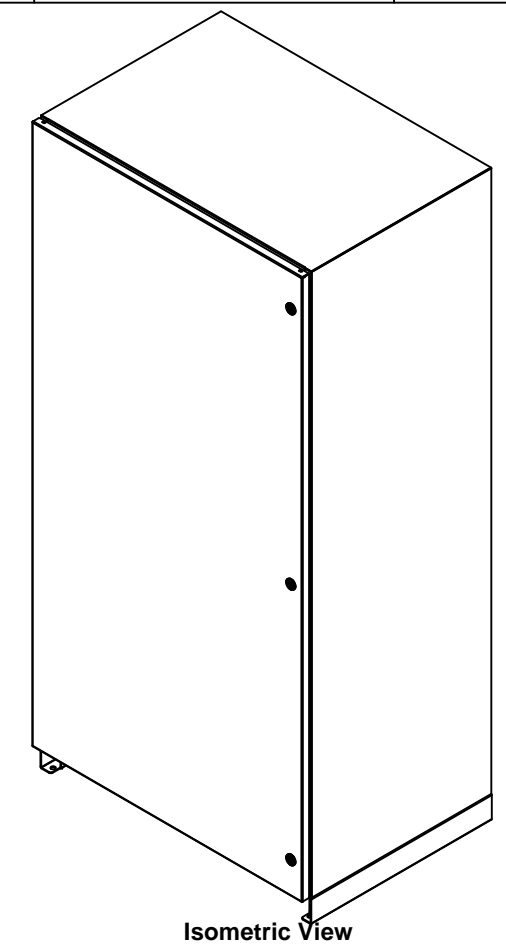

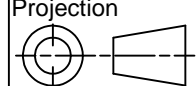
| | | |
|--|---------------------------|---|
|  Tél: (450) 979-4373 Fax: (450) 979-4626 www.exmweb.com | | Flatness Aplatissement Max 3.0mm Projection  |
| Customer Client | Date | |
| Drawn By Dessiné Par | BoxCad: Annie | Date 04/02/2015 |
| Material Matière | 14 Ga H.R.P. & O. (1.7mm) | |
| Color Couleur | Asa-61 Grey | Finish Fini Smooth |
| Description | Detail Rev. | |
| 5100ES 72" x 36" x 24" Assembly | | |
| Part Number Numéro Pièce | Rev. 0 | 2 |
| 5100ESFS723624 | | 2 |

| Qty | Part Number | Rev | Description |
|------------|-----------------|-----|--|
| 1 | STK-K-03000 | 1 | 5100 ES Accessory Kit |
| 1 | 881 SP7236 | 0 | 881 SP - Inner Panel |
| 1 | 5100ESFS723624C | 0 | 5100ES 72" x 36" Cover |
| 8 | STK-Q-07310 | 2 | Flange Lock Nut M8 |
| 8 | STK-Q-07610 | 7 | M8 Plastic Spacer 22.2mm |
| 1 | 5100ESFS723624B | 0 | 5100ES 72" x 36" x 24" Body |
| 4 | STK-Q-04050-07 | 5 | M6 x 7mm Hexagon Socket Head Machine Screw with Nyseal |
| Parts List | | | |

This drawing is confidential and must not be reproduced or used without the consent of EXM

Ce dessin est confidentiel et ne doit pas être reproduit ou utilisé sans le consentement de EXM

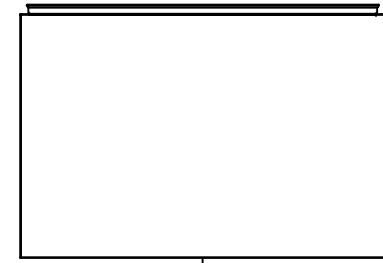

TOP



BACK

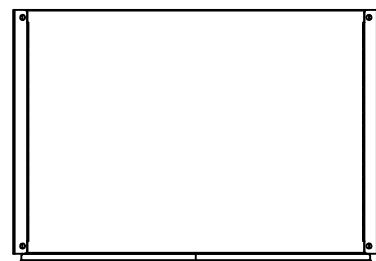

BOTTOM

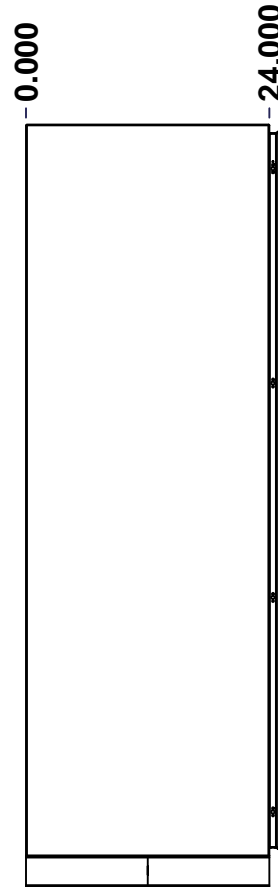

LEFT

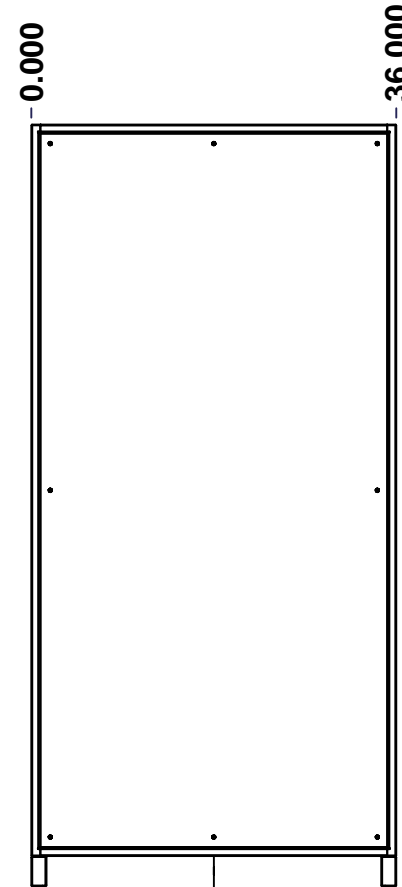

FRONT

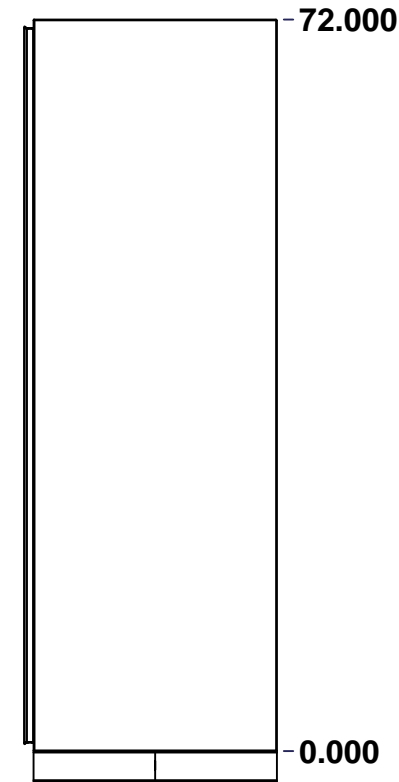

RIGHT

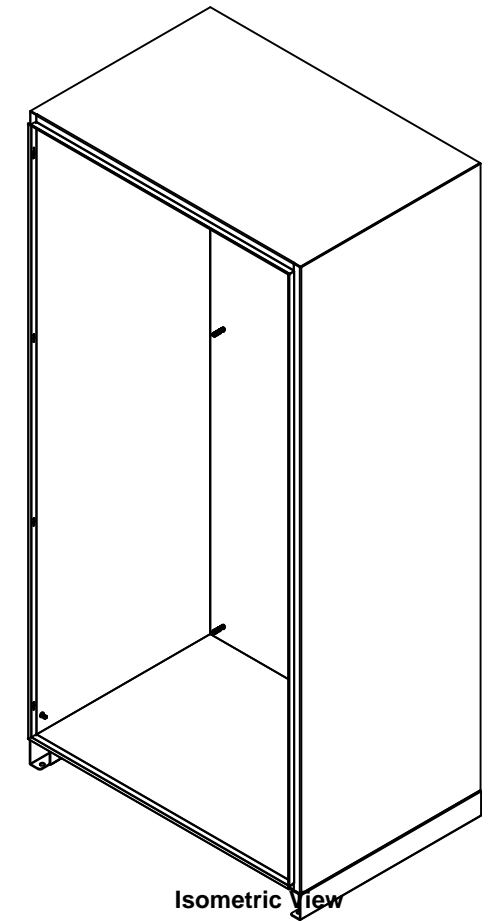

Isometric View

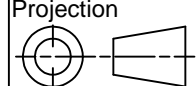

| No. | Revisions | Date | By/Par |
|-----|-----------|------|--------|
| | | | |
| | | | |
| | | | |
| | | | |
| | | | |

| | | |
|--|---------------------------|---|
|  Tél: (450) 979-4373 Fax: (450) 979-4626 www.exmweb.com | | Flatness Aplatissement Max 3.0mm Projection  |
| Customer Client | Date | |
| Drawn By Dessiné Par | BoxCad: Annie | Date 04/02/2015 |
| Material Matière | 14 Ga H.R.P. & O. (1.7mm) | |
| Color Couleur | Asa-61 Grey | Finish Fini Smooth |
| Description | Detail Rev. | |
| 5100ES 72" x 36" x 24" Body | | |
| Part Number Numéro Pièce | Rev. | 1 / 7 |
| 5100ESFS723624B | 0 | |

SEE BILL OF MATERIAL ON LAST PAGE

This drawing is confidential and must not be reproduced or used without the consent of EXM

Ce dessin est confidentiel et ne doit pas être reproduit ou utilisé sans le consentement de EXM

| STANDARD FEATURES ARE NOT LISTED IN THIS HOLE TABLE | | | |
|---|--------|-------|-----------------------------|
| HOLE TABLE - LEFT VIEW (CUSTOM FEATURE ONLY) | | | |
| CUT-OUT | XDIM | YDIM | DESCRIPTION |
| 1 | 22.500 | 1.932 | GND STUD M6 x 16mm (Inside) |

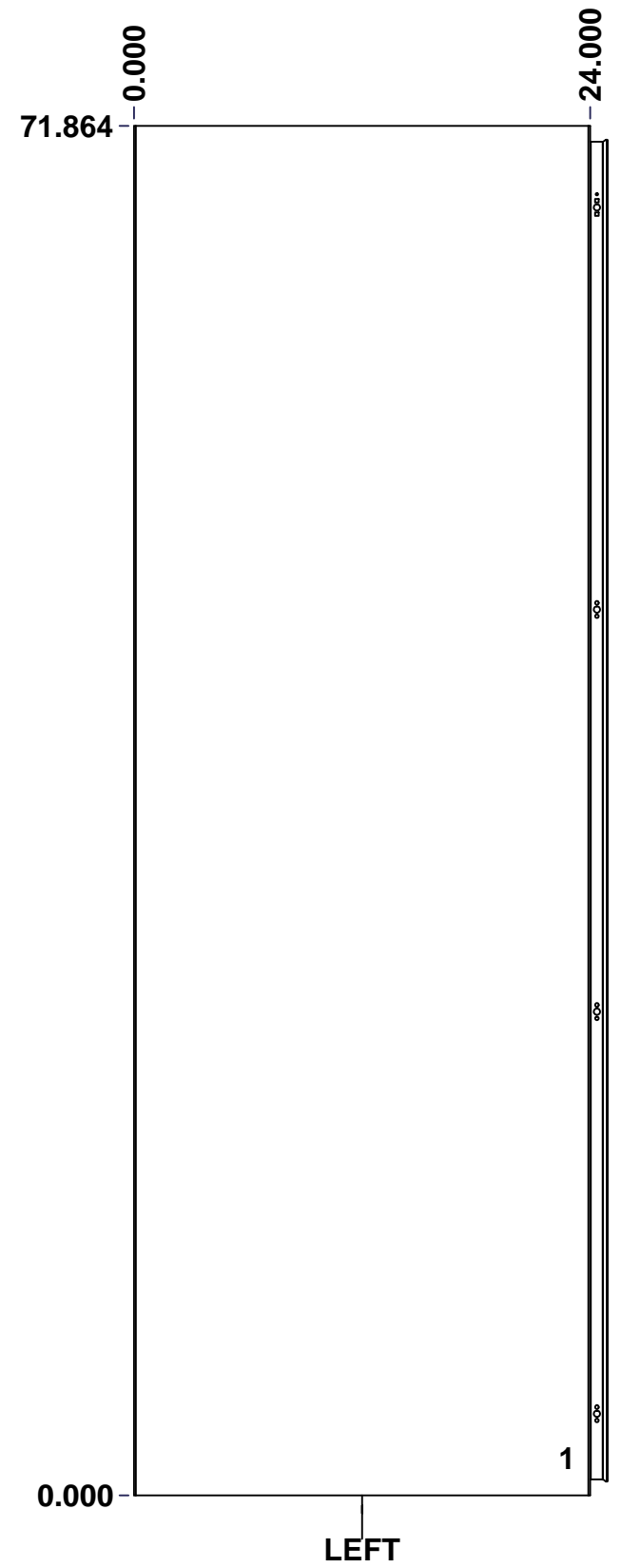

| | | | |
|--|-----------------------------|----------|--------|
| | Description | Status | |
| | 5100ES 72" x 36" x 24" Body | | |
| | Part Number Numéro Pièce | Rev. | 5 7 |
| | 5100ESFS723624B | 0 | |

This drawing is confidential and must not be reproduced or used without the consent of EXM

Ce dessin est confidentiel et ne doit pas être reproduit ou utilisé sans le consentement de EXM

STANDARD FEATURES ARE NOT LISTED IN THIS HOLE TABLE

HOLE TABLE - BACK VIEW (CUSTOM FEATURE ONLY)

| CUT-OUT | XDIM | YDIM | DESCRIPTION |
|---------|--------|--------|----------------------------|
| 1 | 1.807 | 1.807 | IP STUD M8 x 35mm (Inside) |
| 2 | 1.807 | 70.057 | IP STUD M8 x 35mm (Inside) |
| 3 | 34.057 | 70.057 | IP STUD M8 x 35mm (Inside) |
| 4 | 34.057 | 1.807 | IP STUD M8 x 35mm (Inside) |
| 5 | 1.807 | 35.932 | IP STUD M8 x 35mm (Inside) |
| 6 | 34.057 | 35.932 | IP STUD M8 x 35mm (Inside) |
| 7 | 17.932 | 1.807 | IP STUD M8 x 35mm (Inside) |
| 8 | 17.932 | 70.057 | IP STUD M8 x 35mm (Inside) |

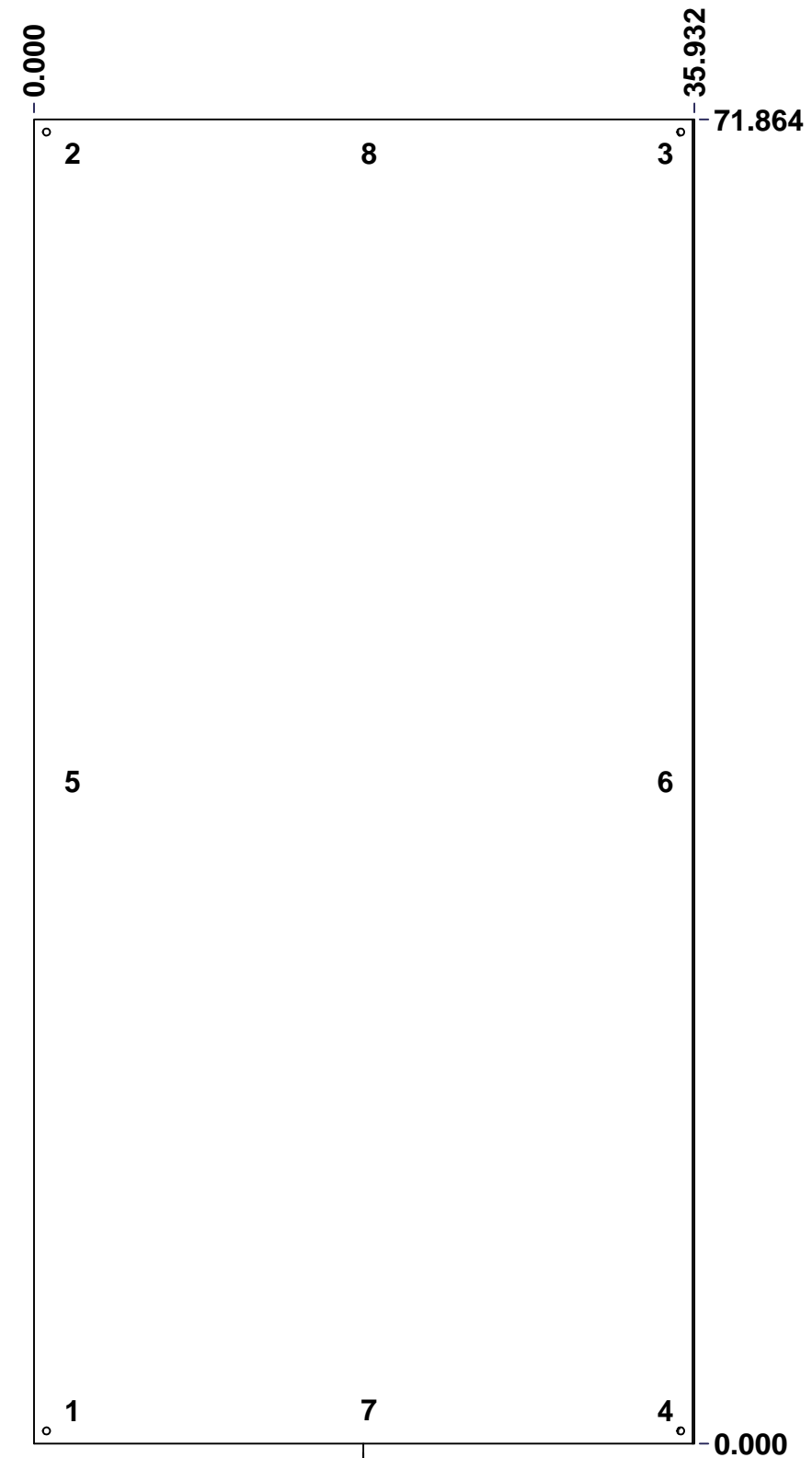

| | | |
|--|-----------------------------|----------|
| | Description | Status |
| | 5100ES 72" x 36" x 24" Body | |
| | Part Number Numéro Pièce | Rev. |
| | 5100ESFS723624B | 0 |
| | | 6 |
| | | 7 |

This drawing is confidential and must not be reproduced or used without the consent of EXM

Ce dessin est confidentiel et ne doit pas être reproduit ou utilisé sans le consentement de EXM

| No. | Revisions | Date | By/Par |
|-----|-----------|------|--------|
| | | | |
| | | | |
| | | | |
| | | | |
| | | | |

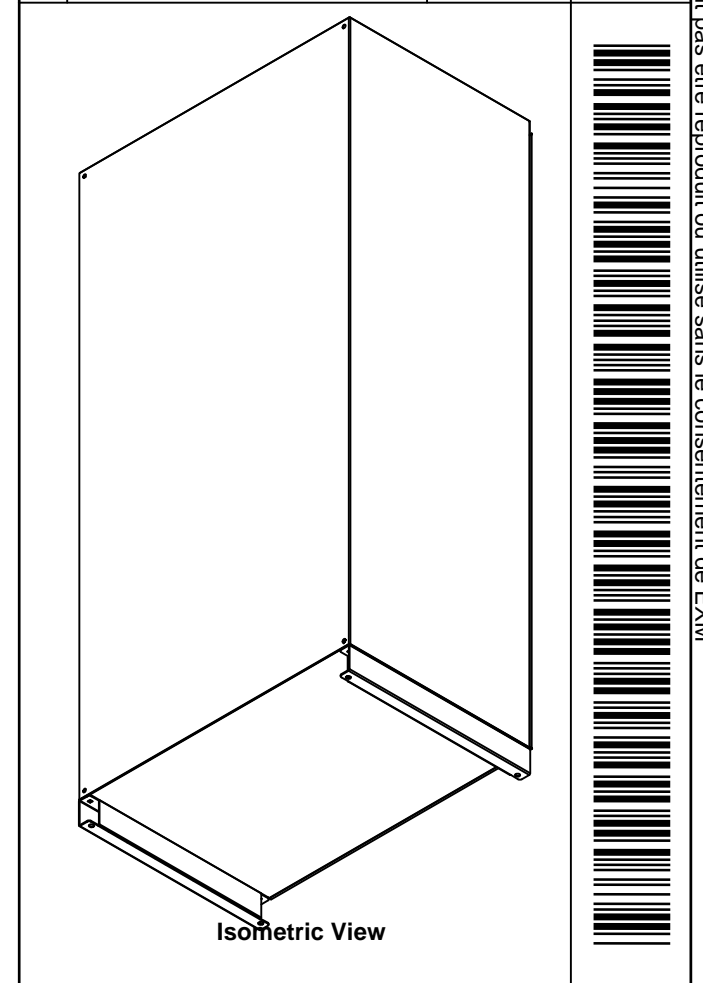

| Qty | Part Number | Rev | Description |
|------------|--------------------|-------|--------------------------------------|
| 1 | 5100ESFS723624MF | 0 | 880 MFT 24" Mounting Feet |
| 1 | STK-P-02400S | 0 | Powder Paint (Asa-61 Grey / Smooth) |
| 8 | STK-Q-16005 | 1 | Stud M8 x 35 (No Paint Cap Required) |
| 1 | STK-Q-16080 | 0.1.1 | M6 x 16mm Ground Stud |
| 1 | 5100ESFS723624BT-P | 0 | 5100ES 72" x 36" x 24" Body Part |
| 1 | 5100ESFS723624T-P | 0 | 5100ES 72" x 36" x 24" Body Part |
| 1 | 5100ESFS723624RS-P | 0 | 5100ES 72" x 36" x 24" Body Part |
| 1 | 5100ESFS723624B-P | 0 | 5100ES 72" x 36" x 24" Body Part |
| Parts List | | | |

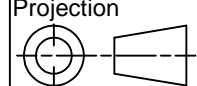
| | | | |
|--|--|---|-------------------------|
|  Tél: (450) 979-4373 Fax: (450) 979-4626 www.exmweb.com | | Flatness Aplatissement Max 3.0mm Projection  | |
| Customer Client | | Date | |
| Drawn By / Dessiné Par: BoxCad: Annie | | Date: 04/02/2015 | |
| Material / Matière: 14 Ga H.R.P. & O. (1.7mm) | | Color / Couleur: Asa-61 Grey | |
| | | Finish / Fini: Smooth | |
| Description: 5100ES 72" x 36" x 24" Body | | | Detail Rev. |
| Part Number / Numéro Pièce: 5100ESFS723624B | | Rev.: | 7 <hr/> 0 <hr/> 7 |

This drawing is confidential and must not be reproduced or used without the consent of EXM

Ce dessin est confidentiel et ne doit pas être reproduit ou utilisé sans le consentement de EXM

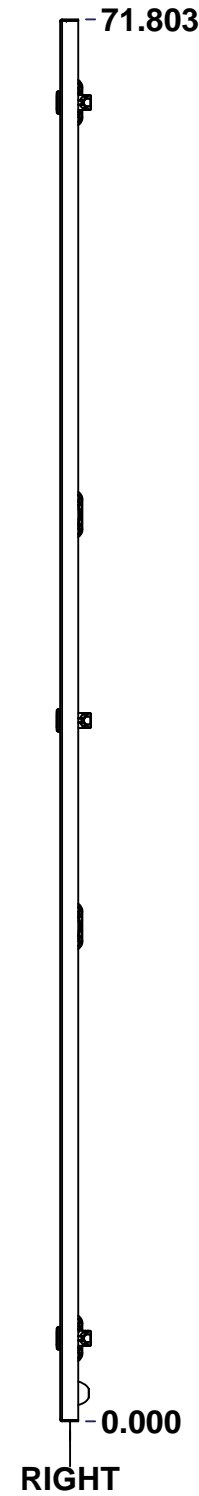
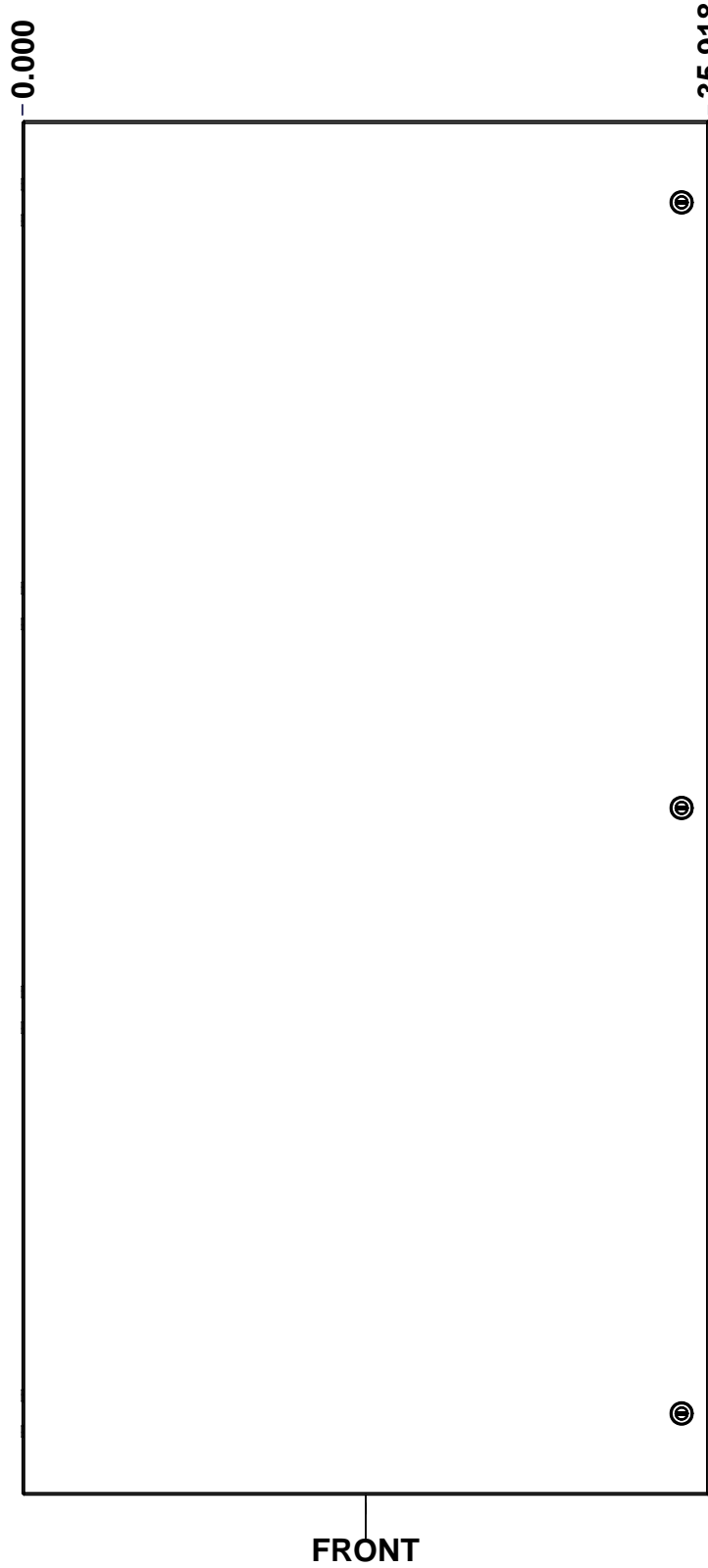
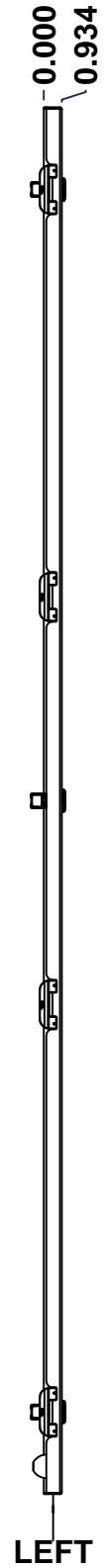
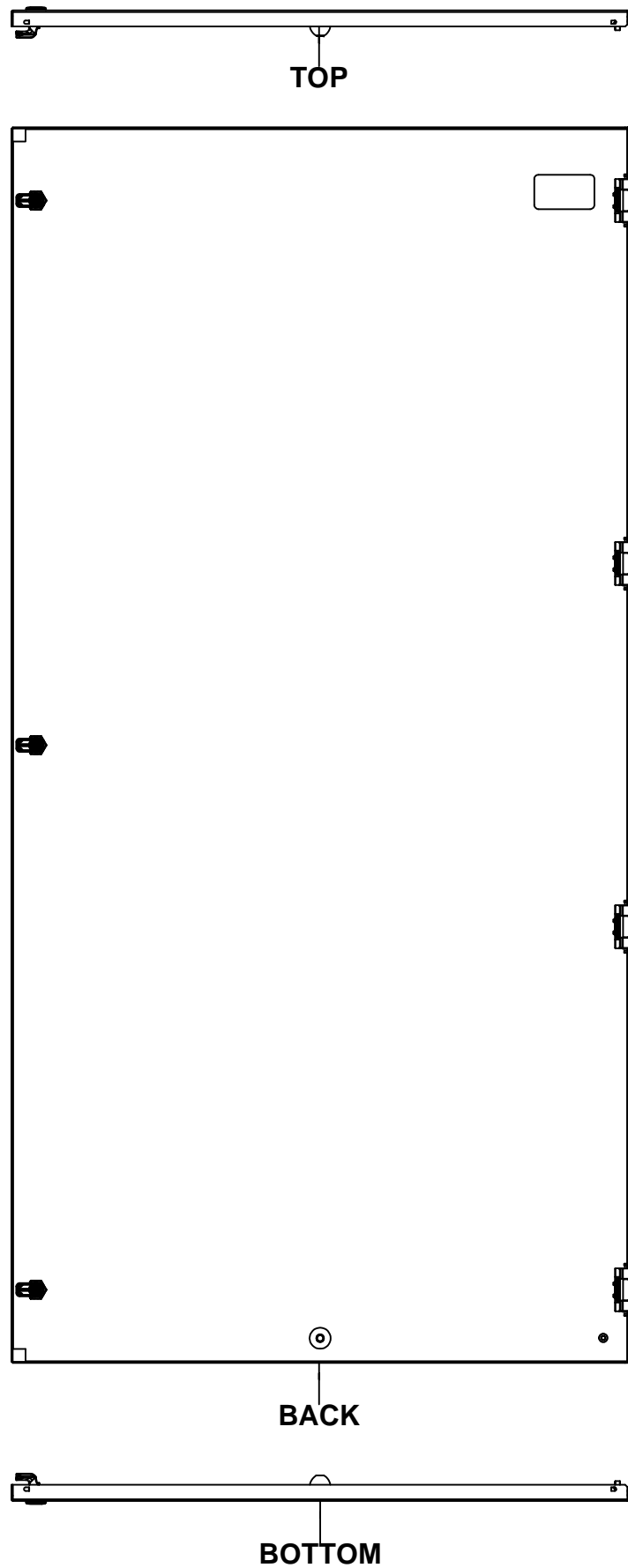

| No. | Revisions | Date | By/Par |
|-----|-----------|------|--------|
| | | | |
| | | | |
| | | | |
| | | | |
| | | | |

Isometric View

| | | | |
|--|-------------|--|----------|
| | | Flatness Aplatissement Max 3.0mm | |
| Tél: (450) 979-4373 Fax: (450) 979-4626 www.exmweb.com | | Projection | |
| Customer Client | | Date | |
| Drawn By Dessiné Par BoxCad: Annie | | Date 04/02/2015 | |
| Material Matière | | 14 Ga H.R.P. & O. (1.7mm) | |
| Color Couleur | Asa-61 Grey | Finish Fini | Smooth |
| Description | | Detail Rev. | |
| 5100ES 72" x 36" Cover | | | |
| Part Number Numéro Pièce | | Rev. | 1 |
| 5100ESFS723624C | | 0 | 3 |

SEE BILL OF MATERIAL ON LAST PAGE

This drawing is confidential and must not be reproduced or used without the consent of EXM

Ce dessin est confidentiel et ne doit pas être reproduit ou utilisé sans le consentement de EXM

| STANDARD FEATURES ARE NOT LISTED IN THIS HOLE TABLE | | | |
|---|--------|-------|-----------------------------|
| HOLE TABLE - FRONT VIEW (CUSTOM FEATURE ONLY) | | | |
| CUT-OUT | XDIM | YDIM | DESCRIPTION |
| 1 | 1.486 | 1.453 | GND STUD M6 x 16mm (Inside) |
| 2 | 17.959 | 1.435 | STUD M6 x 18mm (Inside) |

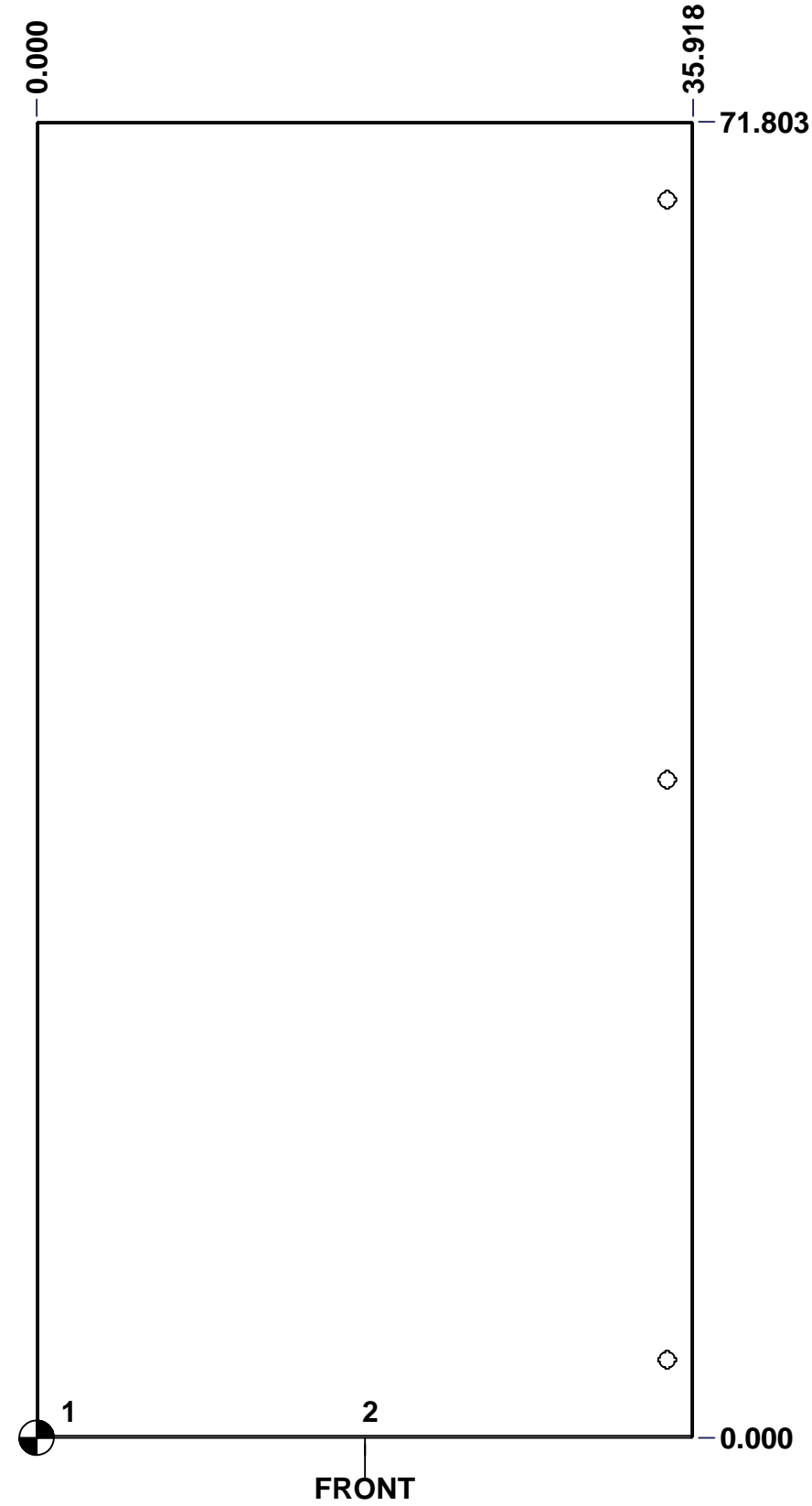

| | | | |
|--|-----------------------------|----------|--------|
| | Description | Status | |
| | 5100ES 72" x 36" Cover | (NULL) | |
| | Part Number Numéro Pièce | Rev. | |
| | 5100ESFS723624C | 0 | 2 3 |

This drawing is confidential and must not be reproduced or used without the consent of EXM

Ce dessin est confidentiel et ne doit pas être reproduit ou utilisé sans le consentement de EXM

| No. | Revisions | Date | By/Par |
|-----|-----------|------|--------|
| | | | |
| | | | |
| | | | |
| | | | |
| | | | |

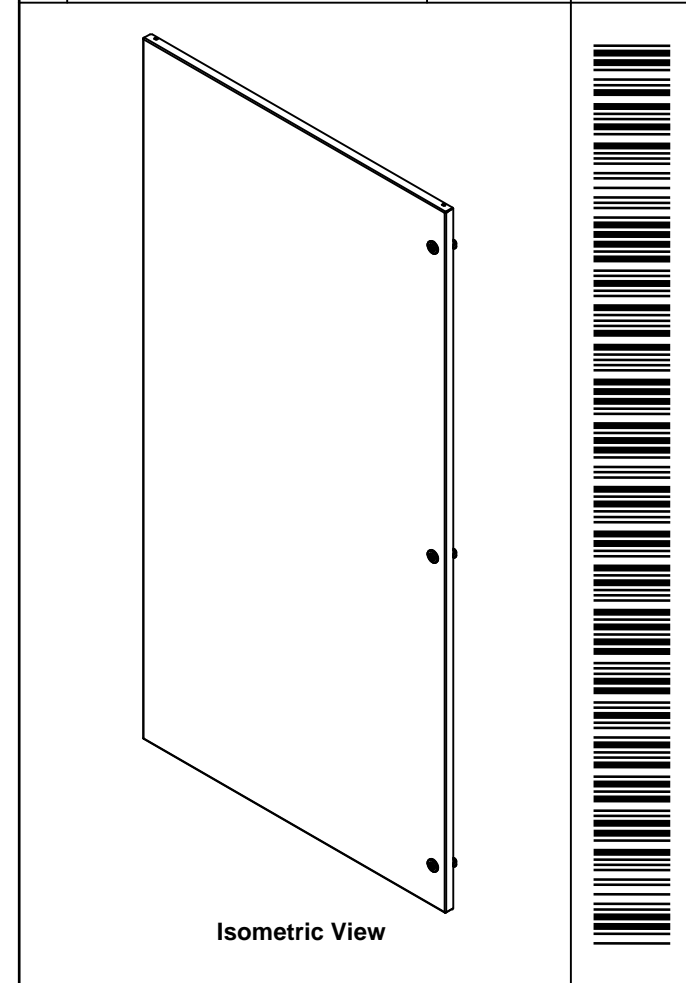

| Qty | Part Name | Rev | Description |
|-----|-------------------|------|---|
| 1 | STK-P-02400S | 0 | Powder Paint (Asa-61 Grey / Smooth) |
| 1 | STK-S-00100 | 0.1. | 3.5" x 2" Silver Milar Flexcon Sticker |
| 1 | STK-Q-16080 | 0.1. | M6 x 16mm Ground Stud |
| 1 | STK-Q-46515 | 3 | 5412 ES Door Support with Brass Insert |
| 1 | STK-Q-16055 | 1 | M6 x 18mm Stud (No Paint Cap Required) |
| 2 | STK-G-00350 | 1 | Rubber Gasket 3/4" x 3/4" x 7/32" |
| 1 | 5100ESFS723624C-P | 0 | 5100ES 72" x 36" Cover Part |
| 4 | STK-K-09800 | 5 | 5412 ES Hinge with 2 Captive Hinge Pins |
| 3 | 880 SCQ4-SL | 0 | 5412 ES 1/4 Turn Lock |
| | | | |
| | | | |

Parts List

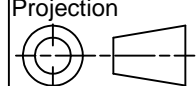
| | | |
|--|---------------------------|---|
|  Tél: (450) 979-4373 Fax: (450) 979-4626 www.exmweb.com | | Flatness Aplatissement Max 3.0mm Projection  |
| Customer Client | Date | |
| Drawn By Dessiné Par | BoxCad: Annie | Date 04/02/2015 |
| Material Matière | 14 Ga H.R.P. & O. (1.7mm) | |
| Color Couleur | Asa-61 Grey | Finish Fini Smooth |
| Description | Detail Rev. | |
| 5100ES 72" x 36" Cover | | |
| Part Number Numéro Pièce | Rev. 3 | 3 |
| 5100ESFS723624C | 0 | 3 |

This drawing is confidential and must not be reproduced or used without the consent of EXM

Ce dessin est confidentiel et ne doit pas être reproduit ou utilisé sans le consentement de EXM

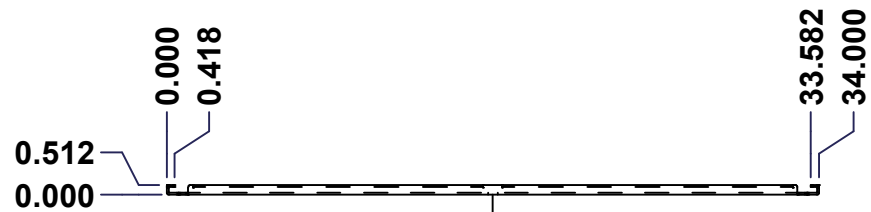

TOP

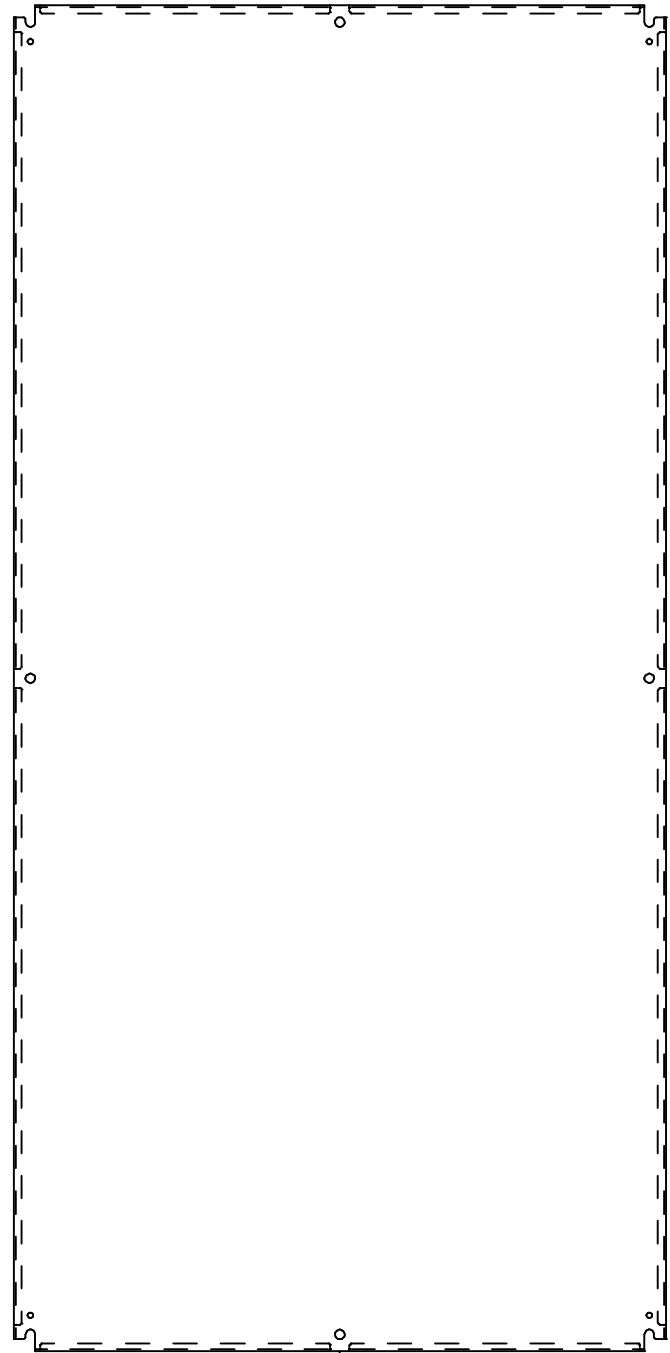

FRONT

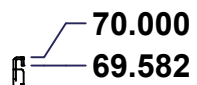

RIGHT

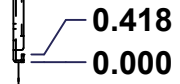

| No. | Revisions | Date | By/Par |
|-----|-----------|------|--------|
| | | | |
| | | | |
| | | | |
| | | | |
| | | | |

Isometric View

| Qty | Part Number | Rev | Description | Material | Color | Finish |
|------------|--------------|-----|-------------------------------|------------------------|---------------|--------|
| 1 | STK-P-02401S | 0 | Powder Paint (White / Smooth) | Polyester-Epoxy Hybrid | White RAL9003 | Smooth |
| 1 | 881 SP7236-P | 0 | 881 SP - Inner Panel Part | 12 Ga H.R.P. & O. | White | Smooth |
| Parts List | | | | | | |

Tél: (450) 979-4373
Fax: (450) 979-4626
www.exmweb.com

Flatness
Aplatissement
Max 3.0mm

Projection

| | |
|--|-------------------------------|
| Customer Client | Date |
| Drawn By Dessiné Par: BoxCad | Date: 1/23/2007 |
| Material Matière: See Part List | |
| Color Couleur: See Part List | Finish Fini: See Part List |
| Description: 881 SP - Inner Panel | |
| Part Number Numéro Pièce: 881 SP7236 | Detail Rev. Rev. 1 0 |

This drawing is confidential and must not be reproduced or used without the consent of EXM

Ce dessin est confidentiel et ne doit pas être reproduit ou utilisé sans le consentement de EXM

| Table 1 | | | FRONT VIEW |
|---------|--------|--------|----------------------------|
| CUT-OUT | XDIM | YDIM | DESCRIPTION |
| 1 | 17.000 | 0.875 | MTG STUD HOLE (RND Ø0.500) |
| 2 | 0.875 | 35.000 | MTG STUD HOLE (RND Ø0.500) |
| 3 | 33.125 | 35.000 | MTG STUD HOLE (RND Ø0.500) |
| 4 | 17.000 | 69.125 | MTG STUD HOLE (RND Ø0.500) |
| 5 | 0.875 | 1.875 | GROUND HOLE (RND Ø0.290) |
| 6 | 33.125 | 1.875 | GROUND HOLE (RND Ø0.290) |
| 7 | 0.875 | 68.125 | GROUND HOLE (RND Ø0.290) |
| 8 | 33.125 | 68.125 | GROUND HOLE (RND Ø0.290) |

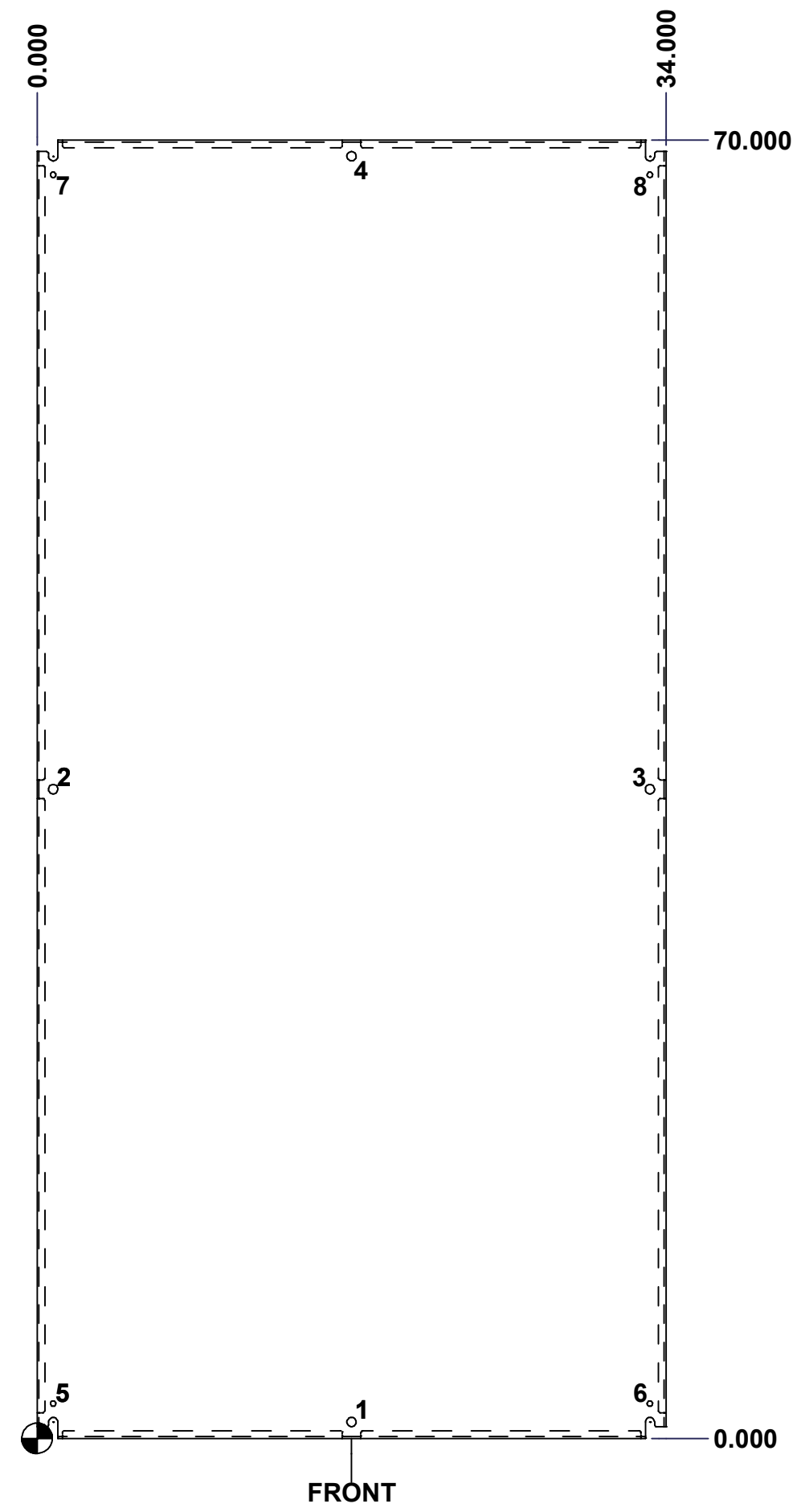

All knockouts are actual size / Les disques défonçables sont grandeur réel

| No. | Revisions | Date | By/Par |
|-----|-----------|------|--------|
| | | | |
| | | | |
| | | | |
| | | | |
| | | | |

Isometric View

| | | |
|-----------------------------|--|------------------------------|
| | Tél: (450) 979-4373 Fax: (450) 979-4626 www.exmweb.com | Flatness Aplatissement |
| | | Max 3.0mm |
| Projection | | |
| Customer Client | Date | |
| Drawn By Dessiné Par | BoxCad | Date 1/23/2007 |
| Material Matière | See Part List | |
| Color Couleur | See Part List | Finish Fini See Part List |
| Description | Detail Rev. | |
| 881 SP - Inner Panel | | |
| Part Number Numéro Pièce | Rev. | 2 |
| 881 SP7236 | | 0 |