

This drawing is confidential and must not be reproduced or used without the consent of EXM

Ce dessin est confidentiel et ne doit pas être reproduit ou utilisé sans le consentement de EXM

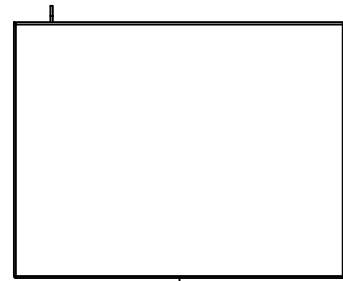

TOP

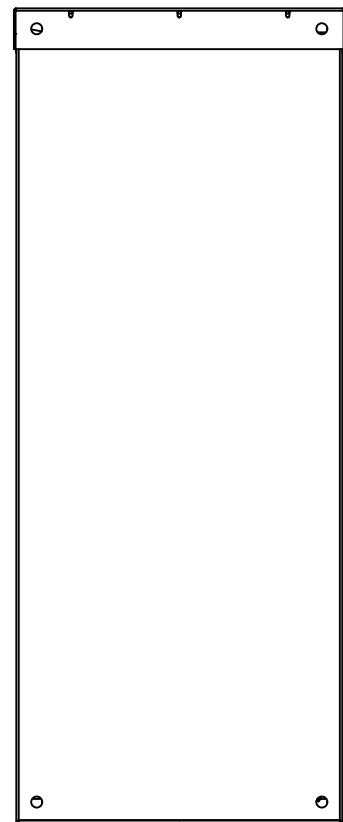

BACK

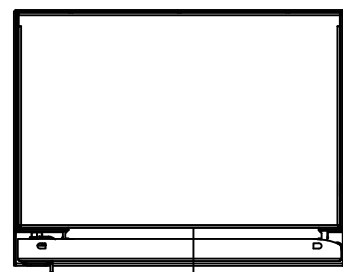

BOTTOM

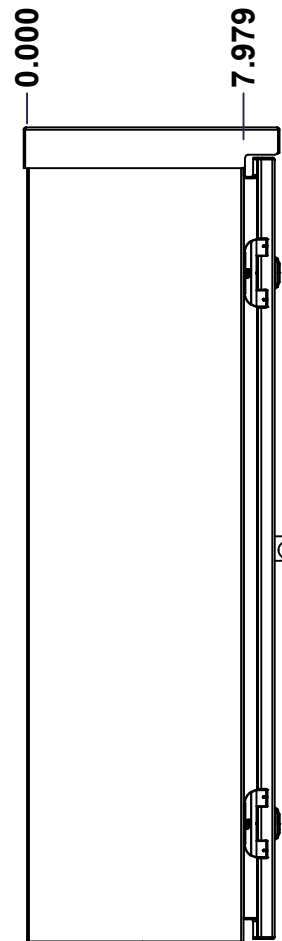

LEFT

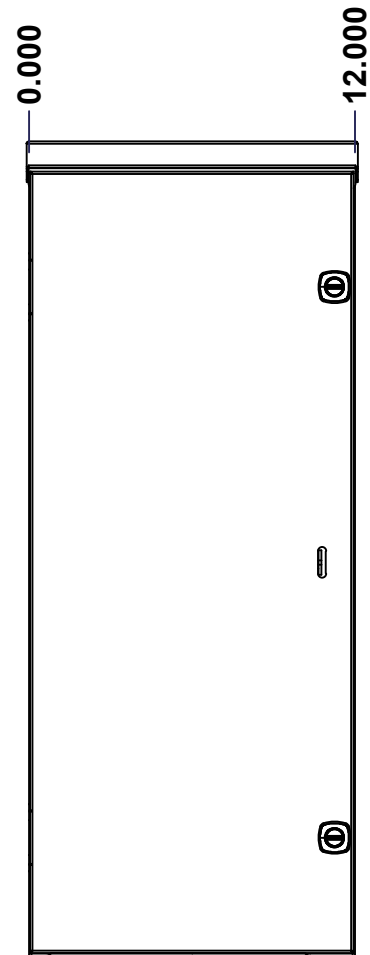

FRONT

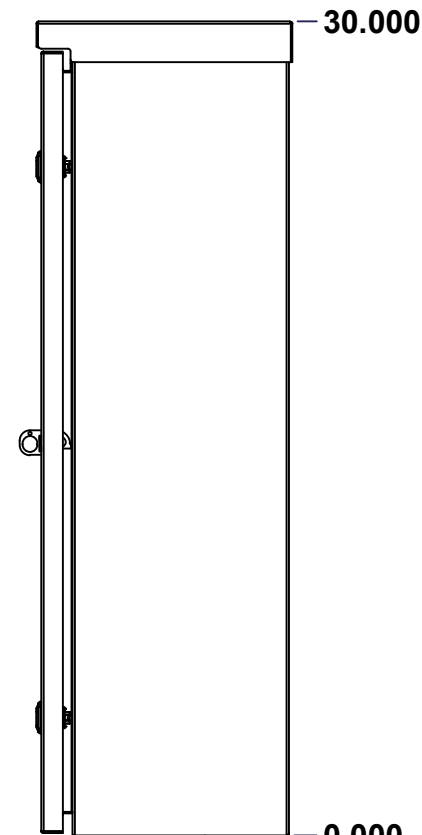

RIGHT

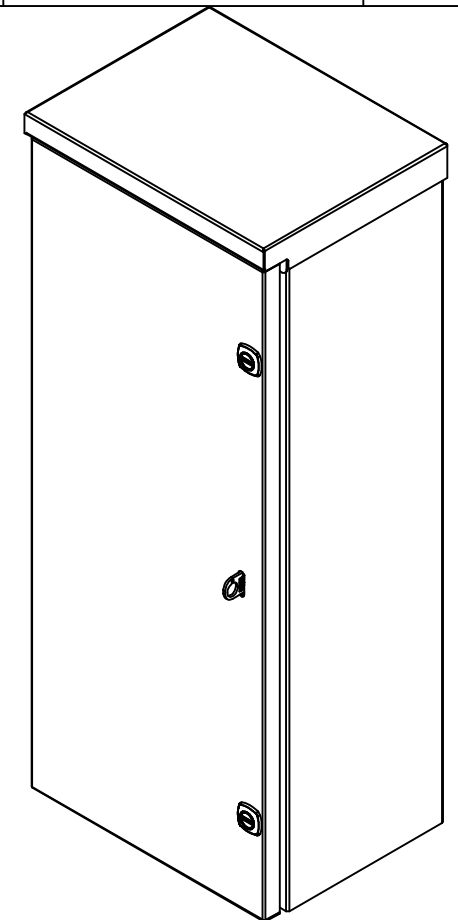

Isometric View

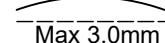
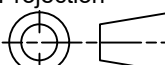

| No. | Revisions | Date | By/Par |
|-----|-----------|------|--------|
| | | | |
| | | | |
| | | | |
| | | | |
| | | | |

| | | |
|--|--------------------------|--|
|  Tél: (450) 979-4373 Fax: (450) 979-4626 www.exmweb.com | | Flatness Aplatissement  Max 3.0mm Projection  |
| Customer Client | Date | |
| Drawn By Dessiné Par | BoxCad: BoxCad | Date 31-Jan-22 |
| Material Matière | 16 Ga Galvanized (1.4mm) | |
| Color Couleur | Asa-61 Grey | Finish Fini Smooth |
| Description | Detail Rev. | |
| 5300ESG 30" x 12" x 8" Assembly | | |
| Part Number Numéro Pièce | Rev. | 1 |
| 5300ESG301208 | 0 | 10 |

SEE BILL OF MATERIAL ON LAST PAGE

This drawing is confidential and must not be reproduced or used without the consent of EXM

Ce dessin est confidentiel et ne doit pas être reproduit ou utilisé sans le consentement de EXM

| NOTE | |
|------|--|
| ITEM | DESCRIPTION |
| 1 | NEMA 3/3R Enclosure |
| 2 | C/W Standard ground studs on box and cover |
| 3 | W/O Standard door stiffener |
| 4 | W/O Inner panel |
| 5 | C/W Standard inner panel mounting studs |
| 6 | C/W Padlock sold separately (Kit) |

| No. | Revisions | Date | By/Par |
|-----|-----------|------|--------|
| | | | |
| | | | |
| | | | |
| | | | |
| | | | |
| | | | |

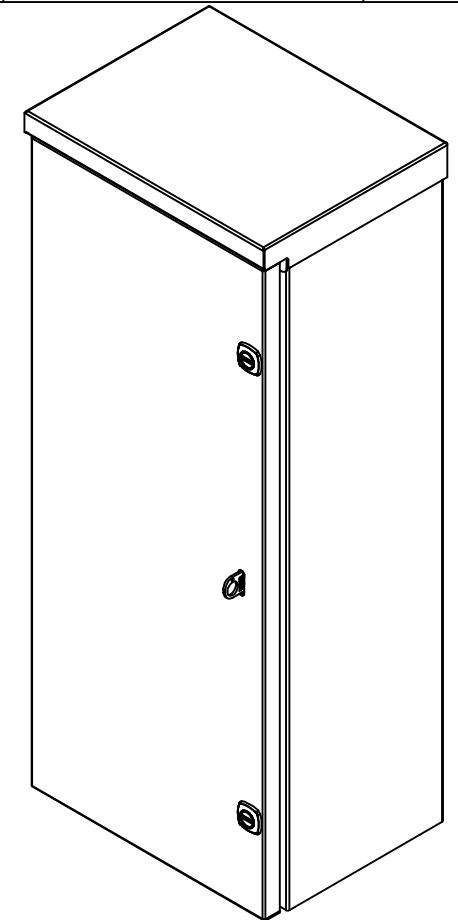

Isometric View

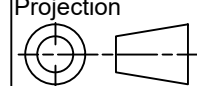
| | | |
|--|---------------------------|---|
|  Tél: (450) 979-4373 Fax: (450) 979-4626 www.exmweb.com | Flatness Aplatissement | Max 3.0mm |
| | Projection |  |
| Customer Client | Date | |
| Drawn By Dessiné Par | BoxCad: BoxCad | Date 31-Jan-22 |
| Material Matière | 16 Ga Galvanized (1.4mm) | |
| Color Couleur | Asa-61 Grey | Finish Fini Smooth |
| Description | Detail Rev. | |
| 5300ESG 30" x 12" x 8" Assembly | | |
| Part Number Numéro Pièce | Rev. | 2 |
| 5300ESG301208 | 0 | 10 |

| PACKING | | |
|-----------------------|-----|--|
| ITEM | QTY | DESCRIPTION |
| Cardboard sleeve | 2 | Top and Bottom |
| Cardboard strip | 2 | Between back of enclosure and inner panel |
| Plastic bag | 1 | To protect cover surface and inside gasket |
| Plastic strap - Black | 2 | To Squeeze the 2 cardboard sleeve together |
| Packaging label | 1 | White label with product number |

| | | | |
|------------|----------------|-----|--|
| 1 | STK-K-03000 | 1 | 5100 ES Accessory Kit |
| 1 | 5300ESG301208C | 0 | 5300ESG 30" x 12" Cover |
| 1 | 5300ESG301208B | 0 | 5300ESG 30" x 12" x 8" Body |
| 2 | STK-Q-04050-08 | 0 | M6 x 8mm Hexagon Socket Head Machine Screw |
| Qty | Part Number | Rev | Description |
| Parts List | | | |

This drawing is confidential and must not be reproduced or used without the consent of EXM

Ce dessin est confidentiel et ne doit pas être reproduit ou utilisé sans le consentement de EXM

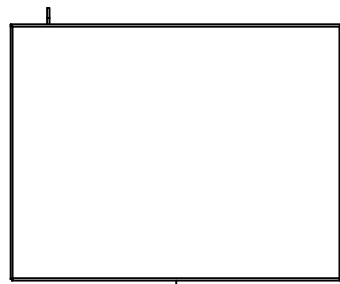

TOP

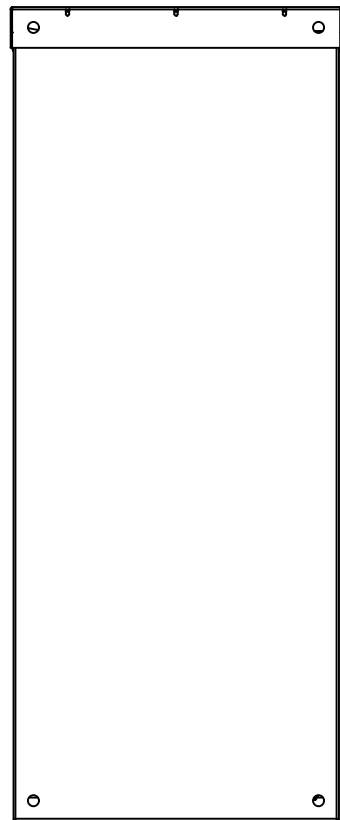

BACK

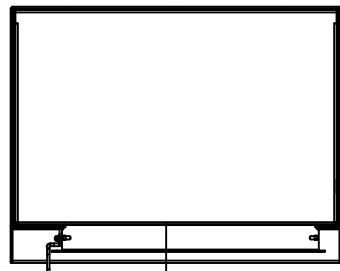

BOTTOM

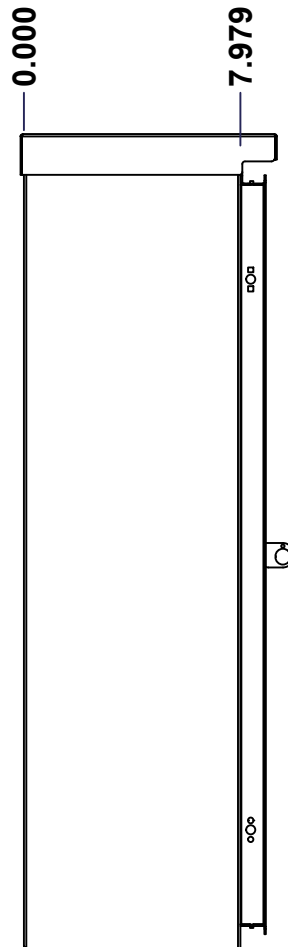

LEFT

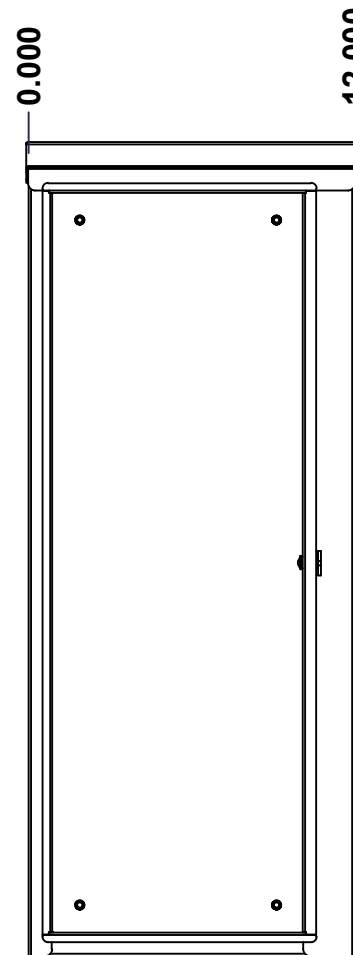

FRONT

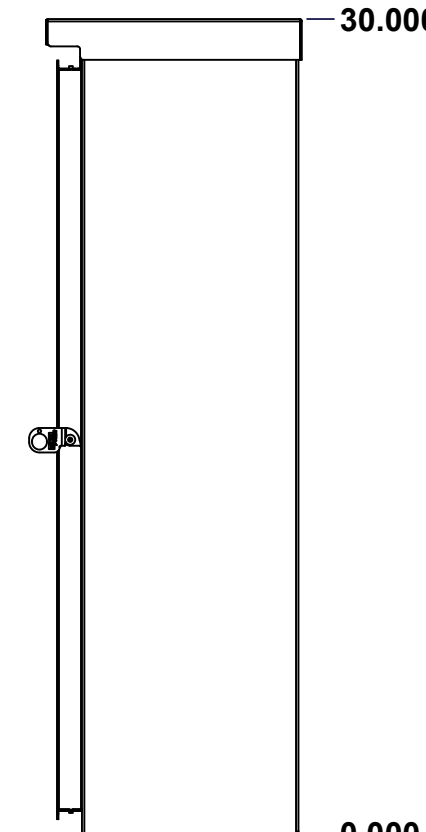

RIGHT

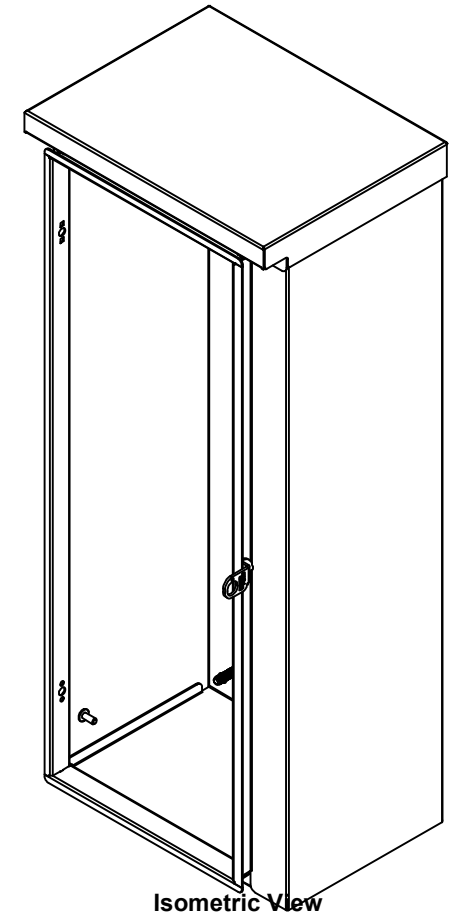

Isometric View

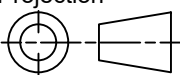

| No. | Revisions | Date | By/Par |
|-----|-----------|------|--------|
| | | | |
| | | | |
| | | | |
| | | | |

| | | |
|--|--------------------------|---|
|  Tél: (450) 979-4373 Fax: (450) 979-4626 www.exmweb.com | | Flatness Aplatissement Max 3.0mm Projection  |
| Customer Client | Date | |
| Drawn By Dessiné Par | BoxCad: BoxCad | Date 31-Jan-22 |
| Material Matière | 16 Ga Galvanized (1.4mm) | |
| Color Couleur | Asa-61 Grey | Finish Fini Smooth |
| Description | Detail Rev. | |
| 5300ESG 30" x 12" x 8" Body | | |
| Part Number Numéro Pièce | Rev. | 3 |
| 5300ESG301208B | 0 | 10 |

SEE BILL OF MATERIAL ON LAST PAGE

This drawing is confidential and must not be reproduced or used without the consent of EXM

Ce dessin est confidentiel et ne doit pas être reproduit ou utilisé sans le consentement de EXM

STANDARD FEATURES ARE NOT LISTED IN THIS HOLE TABLE

HOLE TABLE - RIGHT VIEW (CUSTOM FEATURE ONLY)

| CUT-OUT | XDIM | YDIM | DESCRIPTION |
|---------|-------|--------|-----------------|
| 1 | 8.418 | 14.500 | Padlock 880 PLH |

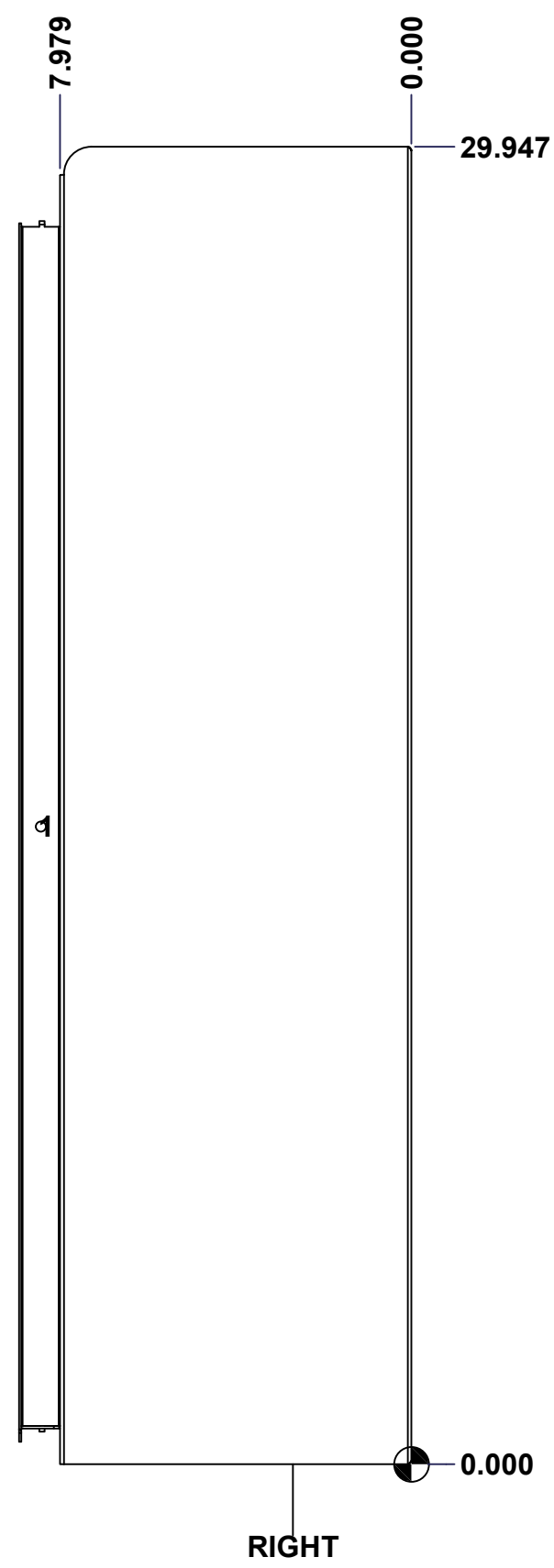

| | | | |
|--|-----------------------------|----------|---------|
| | Description | Status | |
| | 5300ESG 30" x 12" x 8" Body | (NULL) | |
| | Part Number Numéro Pièce | Rev. | |
| | 5300ESG301208B | 0 | 4 10 |

This drawing is confidential and must not be reproduced or used without the consent of EXM

Ce dessin est confidentiel et ne doit pas être reproduit ou utilisé sans le consentement de EXM

| STANDARD FEATURES ARE NOT LISTED IN THIS HOLE TABLE | | | |
|--|-------|-------|-----------------------------|
| HOLE TABLE - LEFT VIEW (CUSTOM FEATURE ONLY) | | | |
| CUT-OUT | XDIM | YDIM | DESCRIPTION |
| 1 | 6.500 | 2.000 | GND STUD M6 x 16mm (Inside) |

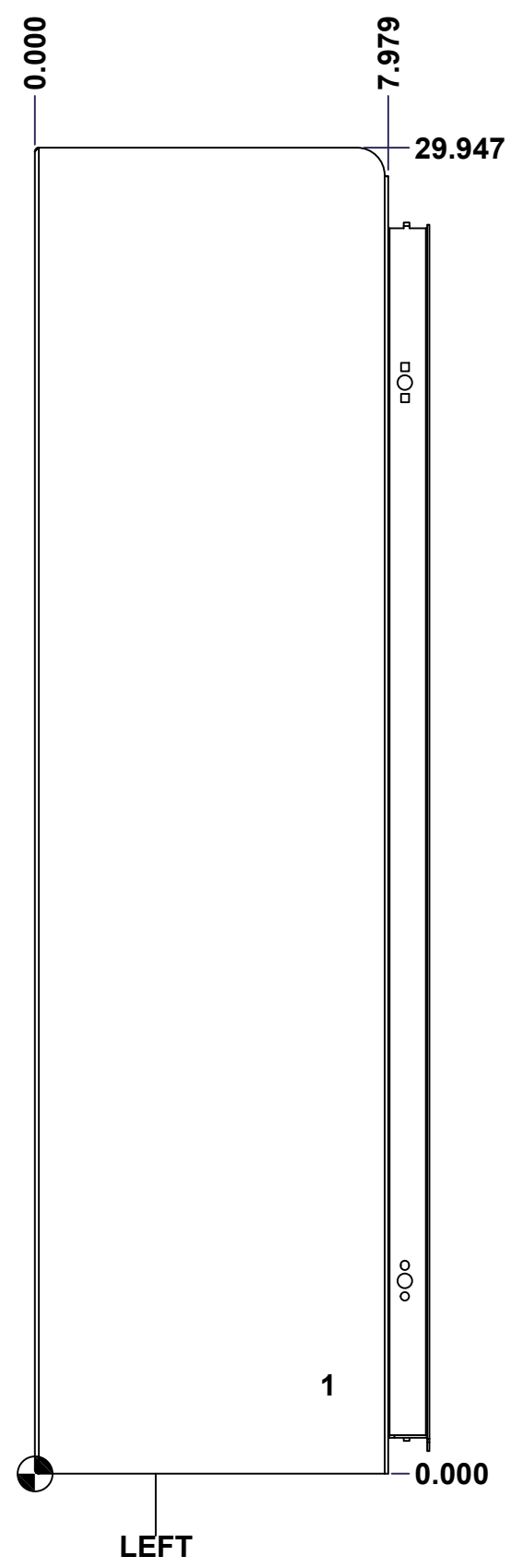

| | | | |
|--|-----------------------------|----------|----|
| | Description | Status | |
| | 5300ESG 30" x 12" x 8" Body | (NULL) | |
| | Part Number Numéro Pièce | Rev. | 5 |
| | 5300ESG301208B | 0 | 10 |

This drawing is confidential and must not be reproduced or used without the consent of EXM

Ce dessin est confidentiel et ne doit pas être reproduit ou utilisé sans le consentement de EXM

STANDARD FEATURES ARE NOT LISTED IN THIS HOLE TABLE

HOLE TABLE - BACK VIEW (CUSTOM FEATURE ONLY)

| CUT-OUT | XDIM | YDIM | DESCRIPTION |
|---------|--------|--------|----------------------------|
| 1 | 3.000 | 3.000 | IP STUD M8 x 35mm (Inside) |
| 2 | 3.000 | 27.000 | IP STUD M8 x 35mm (Inside) |
| 3 | 9.000 | 27.000 | IP STUD M8 x 35mm (Inside) |
| 4 | 9.000 | 3.000 | IP STUD M8 x 35mm (Inside) |
| ----- | | | |
| 5 | 11.250 | 0.750 | RND Ø0.390 |
| 6 | 11.250 | 29.250 | RND Ø0.390 |
| 7 | 0.750 | 29.250 | RND Ø0.390 |
| 8 | 0.750 | 0.750 | RND Ø0.390 |

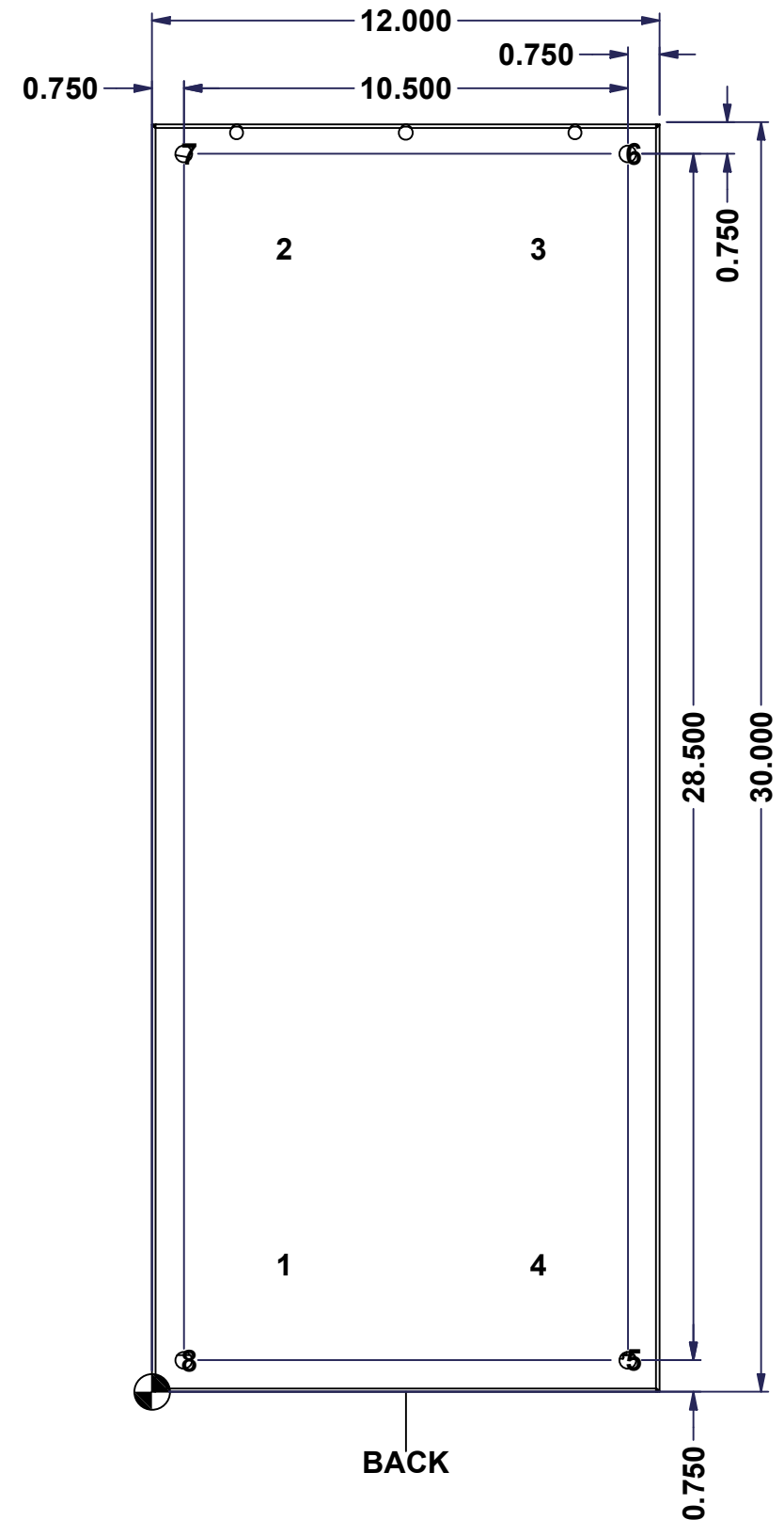

| | | |
|--|-----------------------------|--------------|
| | Description | Status |
| | 5300ESG 30" x 12" x 8" Body | (NULL) |
| | Part Number Numéro Pièce | Rev. |
| | 5300ESG301208B | 0 / 6 |
| | | 10 |

This drawing is confidential and must not be reproduced or used without the consent of EXM

Ce dessin est confidentiel et ne doit pas être reproduit ou utilisé sans le consentement de EXM

| No. | Revisions | Date | By/Par |
|-----|-----------|------|--------|
| | | | |
| | | | |
| | | | |
| | | | |
| | | | |

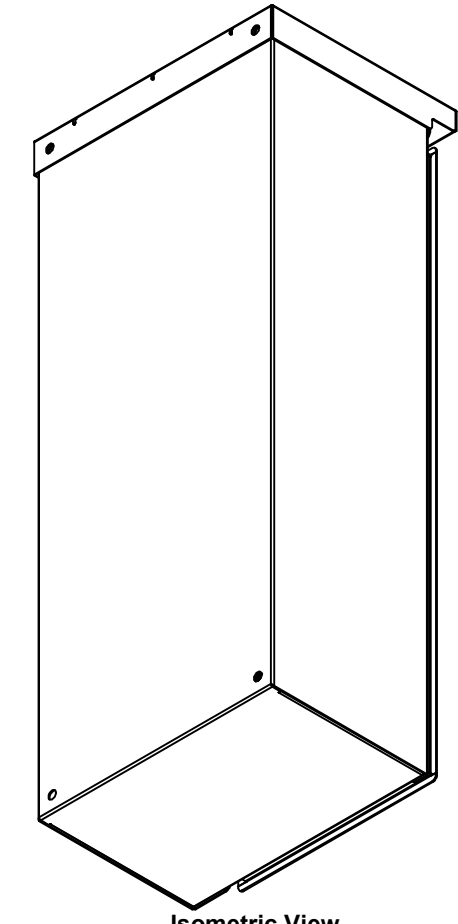

Isometric View



| | | |
|--|-----------------------|--|
|  Tél: (450) 979-4373 Fax: (450) 979-4626 www.exmweb.com | | Flatness Aplatissement Max 3.0mm |
| Customer Client | | Date |
| Drawn By / Dessiné Par: BoxCad: BoxCad | | Date: 31-Jan-22 |
| Material / Matière: 16 Ga Galvanized (1.4mm) | | |
| Color / Couleur: Asa-61 Grey | Finish / Fini: Smooth | |
| Description: 5300ESG 30" x 12" x 8" Body | | Detail Rev. |
| Part Number / Numéro Pièce: 5300ESG301208B | | Rev. 7 / 10 |

| Qty | Part Number | Rev | Description |
|------------|------------------|-----|--------------------------------------|
| 1 | STK-Q-16080 | 0 | Ground Stud M6 x 16mm Steel |
| 1 | STK-K-91208 | 0 | 5300 ESG Padlock Kit |
| 1 | STK-P-02400S | 0 | Powder Paint (Asa-61 Grey / Smooth) |
| 4 | STK-Q-16005 | 1 | Stud M8 x 35 (No Paint Cap Required) |
| 1 | 5300ESG301208T-P | 0 | 5300ESG 30" x 12" x 8" Top Part |
| 1 | 5300ESG301208B-P | 0 | 5300ESG 30" x 12" x 8" Body Part |
| Parts List | | | |

This drawing is confidential and must not be reproduced or used without the consent of EXM

Ce dessin est confidentiel et ne doit pas être reproduit ou utilisé sans le consentement de EXM

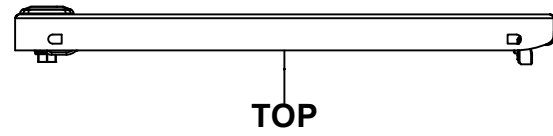

TOP

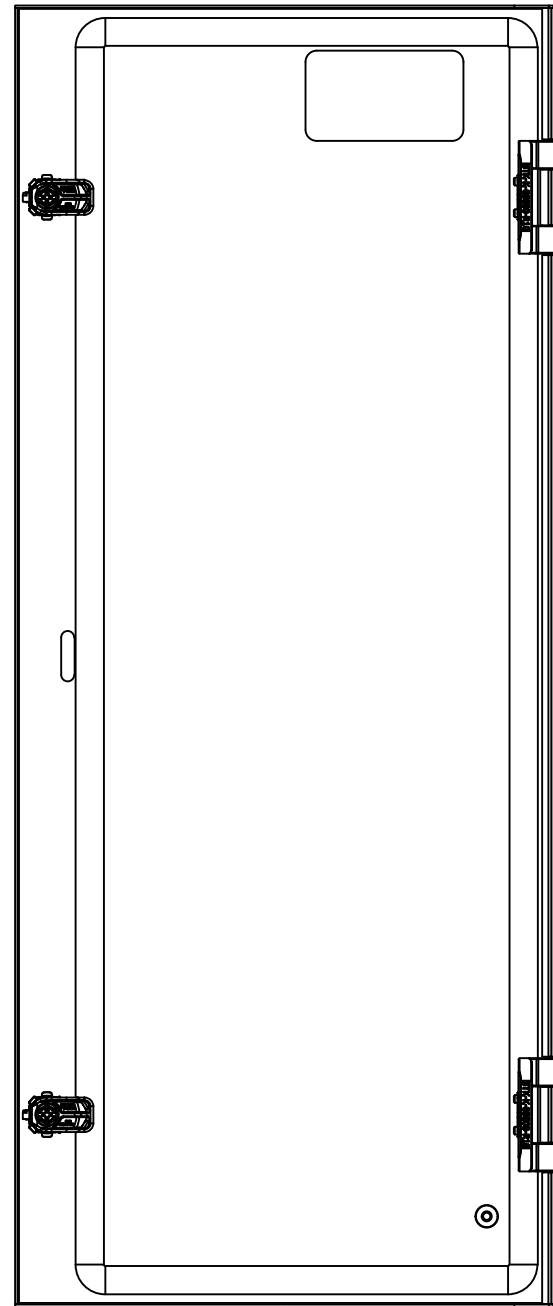

BACK

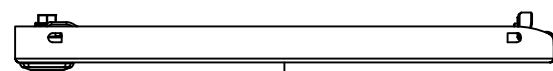

BOTTOM

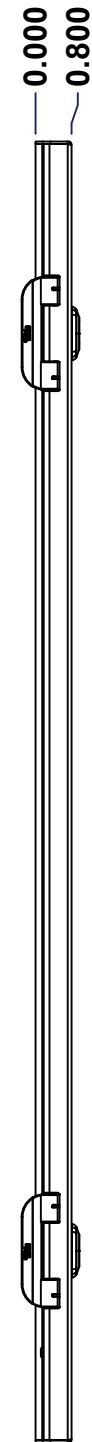

LEFT

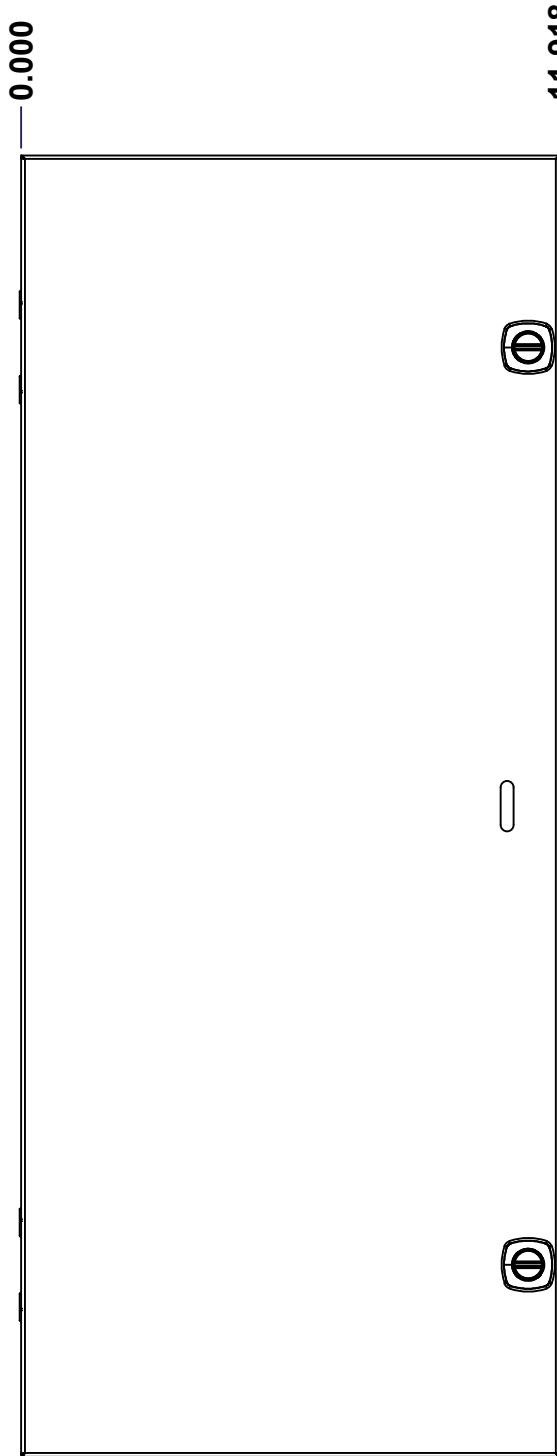

FRONT

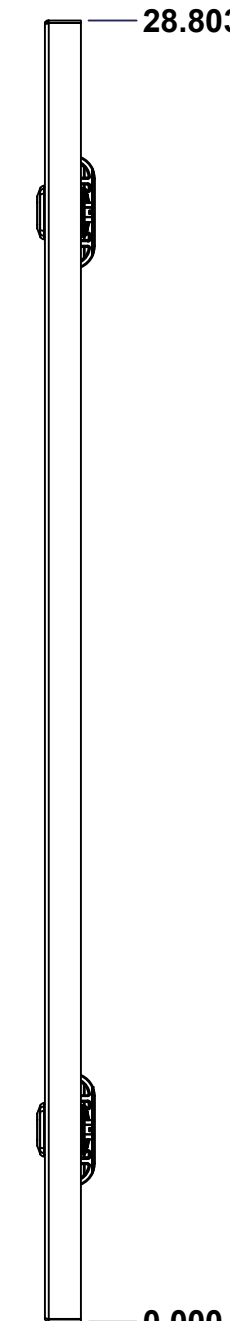

RIGHT

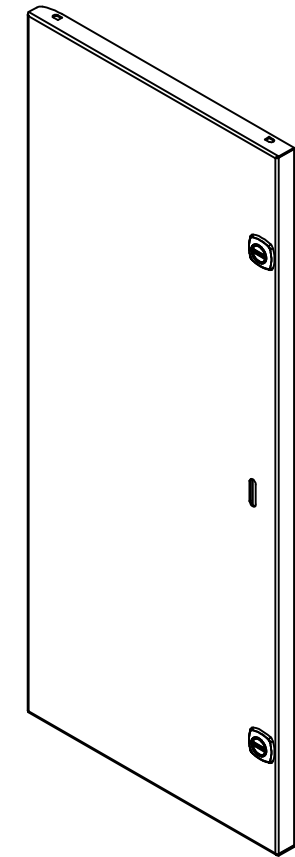

Isometric View



| No. | Revisions | Date | By/Par |
|-----|-----------|------|--------|
| | | | |
| | | | |
| | | | |
| | | | |
| | | | |

| | | |
|--|----------------|---------------------------|
|  Tél: (450) 979-4373 Fax: (450) 979-4626 www.exmweb.com | | Flatness Aplatissement |
| | | Max 3.0mm |
| Customer Client | | Date |
| Drawn By Dessiné Par | BoxCad: BoxCad | Date 31-Jan-22 |
| Material Matière 16 Ga Galvanized (1.4mm) | | |
| Color Couleur | Asa-61 Grey | Finish Fini Smooth |
| Description 5300ESG 30" x 12" Cover | | Detail Rev. |
| Part Number Numéro Pièce | Rev. 8 | 10 |
| SEE BILL OF MATERIAL ON LAST PAGE | | 5300ESG301208C |

This drawing is confidential and must not be reproduced or used without the consent of EXM

Ce dessin est confidentiel et ne doit pas être reproduit ou utilisé sans le consentement de EXM

STANDARD FEATURES ARE NOT LISTED IN THIS HOLE TABLE

HOLE TABLE - FRONT VIEW (CUSTOM FEATURE ONLY)

| CUT-OUT | XDIM | YDIM | DESCRIPTION |
|---------|--------|--------|-----------------------------|
| 1 | 10.755 | 14.401 | Padlock 880 PLH |
| 2 | 3.750 | 26.803 | LABEL_EXM (Inside) |
| 3 | 1.486 | 2.000 | GND STUD M6 x 16mm (Inside) |
| 4 | 11.218 | 24.553 | 880 SCQ4CH-SL |
| 5 | 11.218 | 4.250 | 880 SCQ4CH-SL |

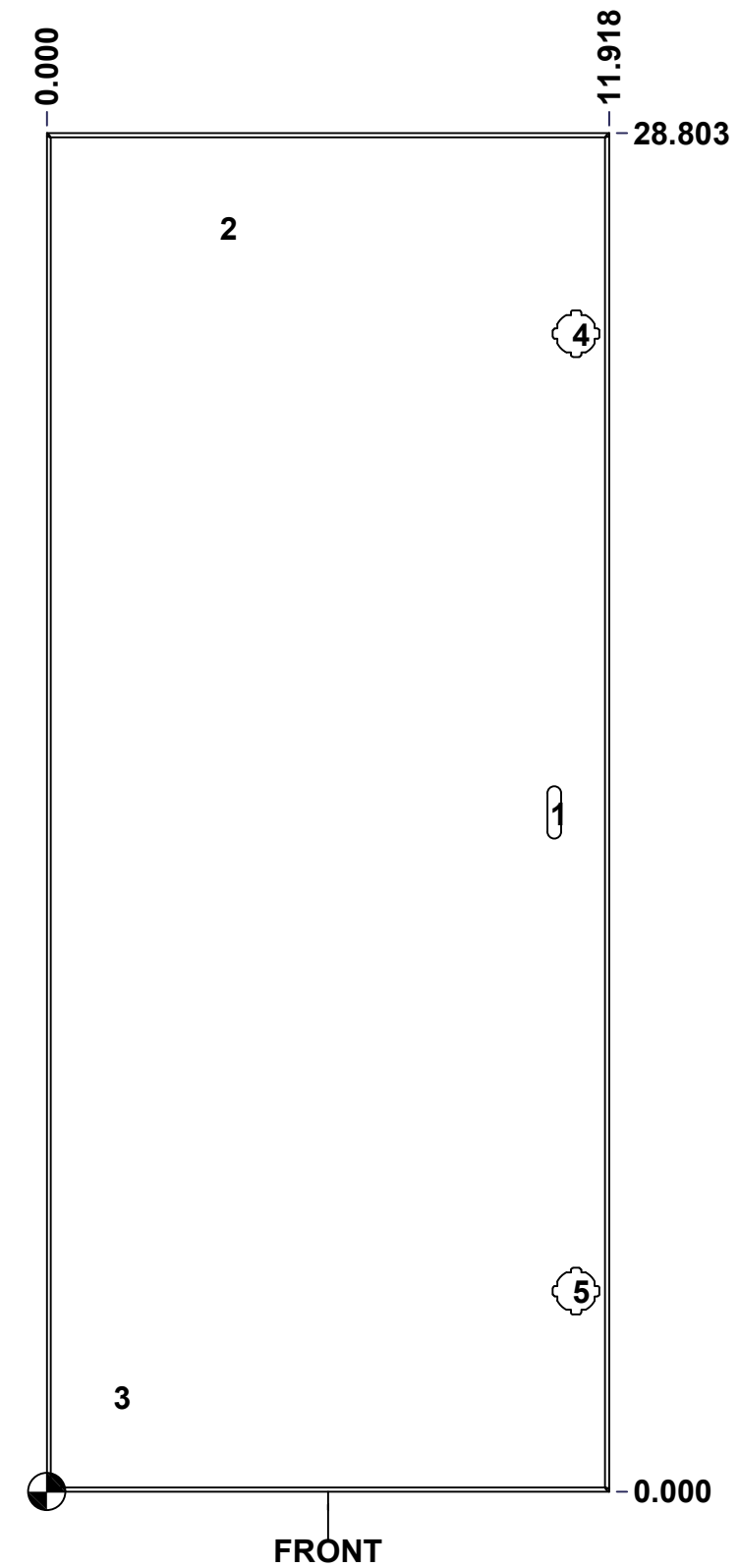

| | | |
|--|-----------------------------|----------|
| | Description | Status |
| | 5300ESG 30" x 12" Cover | (NULL) |
| | Part Number Numéro Pièce | Rev. |
| | 5300ESG301208C | 0 |
| | | 9 |
| | | 10 |

This drawing is confidential and must not be reproduced or used without the consent of EXM

Ce dessin est confidentiel et ne doit pas être reproduit ou utilisé sans le consentement de EXM

| No. | Revisions | Date | By/Par |
|-----|-----------|------|--------|
| | | | |
| | | | |
| | | | |
| | | | |
| | | | |

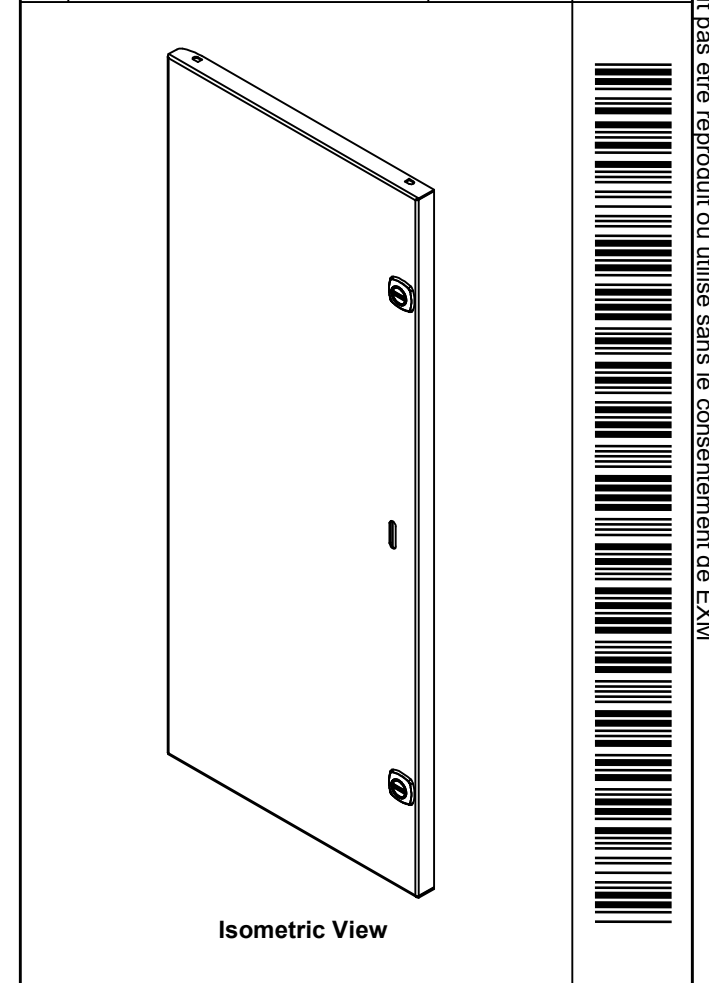

EXM
www.exmweb.com

Tél: (450) 979-4373
Fax: (450) 979-4626

Flatness
Aplatissement
Max 3.0mm

Projection

| | |
|--|-----------------|
| Customer Client | Date |
| Drawn By / Dessiné Par: BoxCad: BoxCad | Date: 31-Jan-22 |

Material / Matière: 16 Ga Galvanized (1.4mm)

| | |
|------------------------------|-----------------------|
| Color / Couleur: Asa-61 Grey | Finish / Fini: Smooth |
|------------------------------|-----------------------|

Description: 5300ESG 30" x 12" Cover

Detail Rev.

| | | |
|---|--------|---------|
| Part Number / Numéro Pièce: 5300ESG301208C | Rev. 0 | 10 / 10 |
|---|--------|---------|

| QTY | Part Number | Rev | Description |
|------------|------------------|-----|---|
| 1 | STK-Q-16080 | 0 | Ground Stud M6 x 16mm Steel |
| 1 | STK-S-00100 | 0 | 3.5" x 2" Silver Milar Flexcon Sticker |
| 1 | STK-P-02400S | 0 | Powder Paint (Asa-61 Grey / Smooth) |
| 1 | 5300ESG301208G | 0 | 5300ESG 30" x 12" Cover Gasket Part |
| 1 | 5300ESG301208C-P | 0 | 5300ESG 30" x 12" Cover Part |
| 2 | 880 SCQ4CH-SL | 0 | 5412 CH 1/4 Turn Lock |
| 2 | STK-K-09800 | 10 | 5412 ES Hinge with 2 Captive Hinge Pins |
| Parts List | | | |