

This drawing is confidential and must not be reproduced or used without the consent of EXM

Ce dessin est confidentiel et ne doit pas être reproduit ou utilisé sans le consentement de EXM

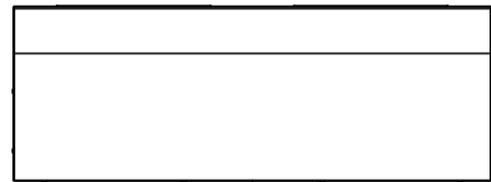

TOP

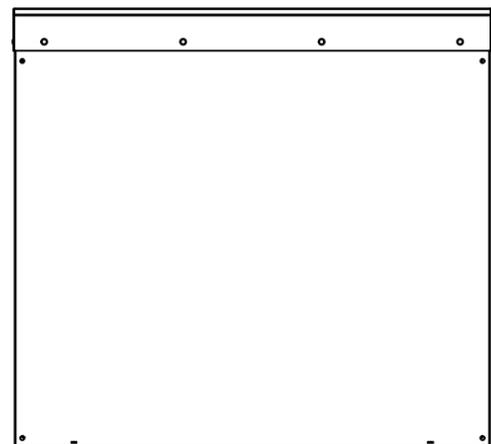

BACK

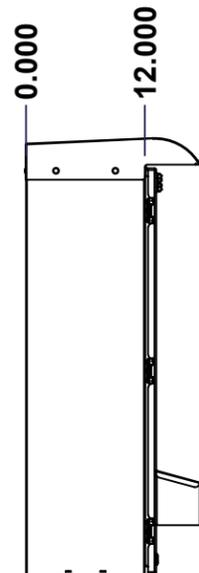

LEFT

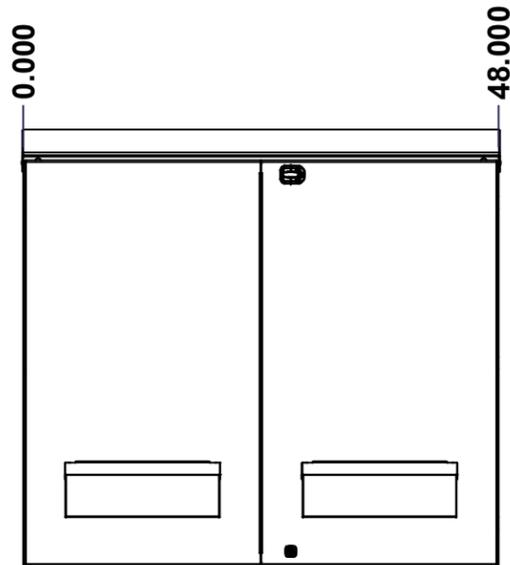

FRONT

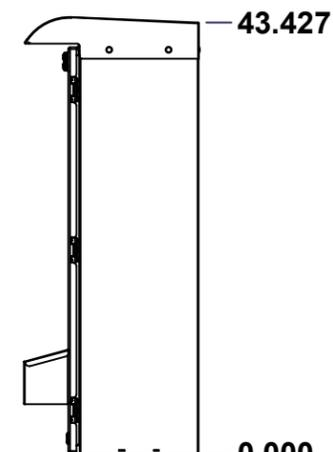

RIGHT

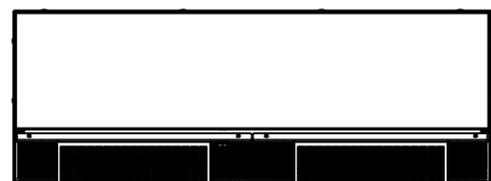

BOTTOM

No.	Revisions	Date	By/Par

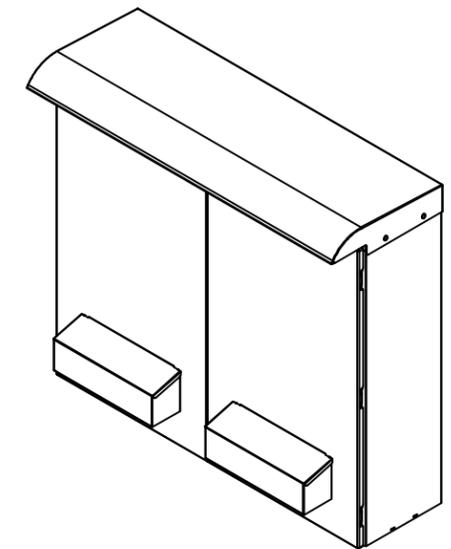

Isometric View



Tél: (450) 979-4373  
 Fax: (450) 979-4626  
[www.exmweb.com](http://www.exmweb.com)

Flatness  
Aplatissement

Max 3.0mm

Projection

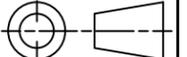

Customer Client	Date
Drawn By Dessiné Par BoxCad: BoxCad	Date 03-Sep-20
Material Matière 14 Ga Cold Rolled A1008 CS Type B (1.7mm)	
Color Couleur White RAL9003	Finish Fini Rough Textured
Description 5300EWBDD 41" x 48" x 12" Assembly	Detail Rev.
Part Number Numéro Pièce 5300EWBDD414812	Rev. 1
	0

SEE BILL OF MATERIAL ON LAST PAGE

This drawing is confidential and must not be reproduced or used without the consent of EXM

Ce dessin est confidentiel et ne doit pas être reproduit ou utilisé sans le consentement de EXM

NOTE	
ITEM	DESCRIPTION
1	NEMA 3/3R Enclosure
2	C/W Powdura® Epoxy Powder Coating Primer
3	C/W Standard ground studs on box and cover
4	W/O Standard door stiffener
5	W/O Inner panel
6	C/W Standard inner panel mounting studs
7	C/W 01141.9-00 Included (Installed)

No.	Revisions	Date	By/Par

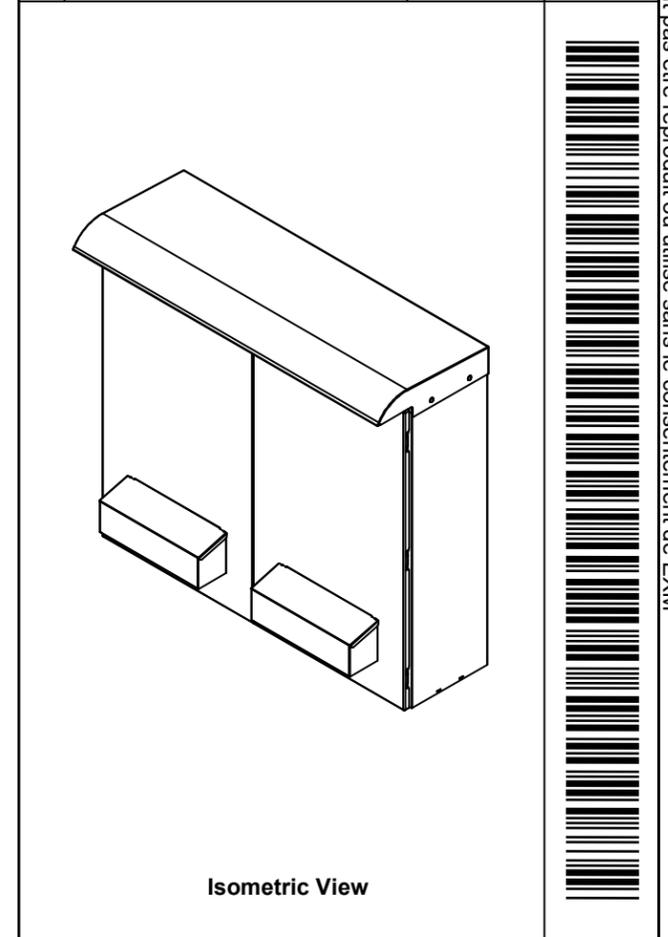

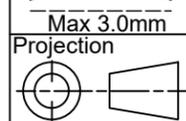
 Tél: (450) 979-4373 Fax: (450) 979-4626 <a href="http://www.exmweb.com">www.exmweb.com</a>	Flatness Aplatissement  Max 3.0mm
	Projection 
Customer Client	Date
Drawn By / Dessiné Par: BoxCad: BoxCad	Date: 03-Sep-20
Material / Matière: 14 Ga Cold Rolled A1008 CS Type B (1.7mm)	
Color / Couleur: White RAL9003	Finish / Fini: Rough Textured

PACKING		
ITEM	QTY	DESCRIPTION
Cardboard sleeve	2	Top and Bottom
Cardboard strip	2	Between back of enclosure and inner panel
Plastic bag	1	To protect cover surface and inside gasket
Plastic strap - Black	2	To Squeeze the 2 cardboard sleeve together
Packaging label	1	White label with product number

Qty	Part Number	Rev	Description
1	5300EWBDD414812FD	0	5300EWBDD 41" x 48" x 12" Flang Door
1	5300EWBDD414812LD	0	5300EWBDD 41" x 48" x 12" Lock Door
1	5300EWBDD414812B	0	5300EWBDD 41" x 48" x 12" Body
Parts List			

Description: 5300EWBDD 41" x 48" x 12" Assembly		Detail Rev.	
Part Number / Numéro Pièce: <b>5300EWBDD414812</b>		Rev.:	2
		<b>0</b>	13

This drawing is confidential and must not be reproduced or used without the consent of EXM

Ce dessin est confidentiel et ne doit pas être reproduit ou utilisé sans le consentement de EXM

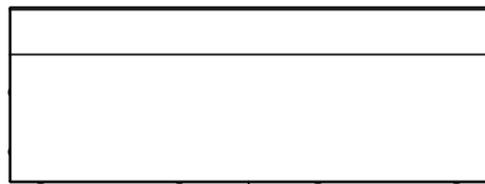

TOP

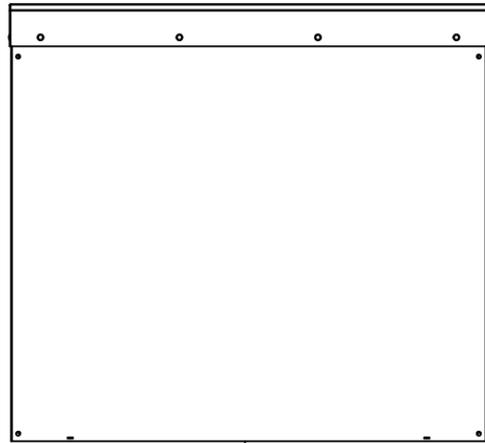

BACK

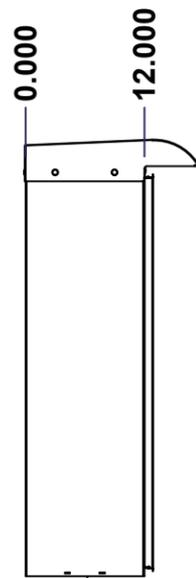

LEFT

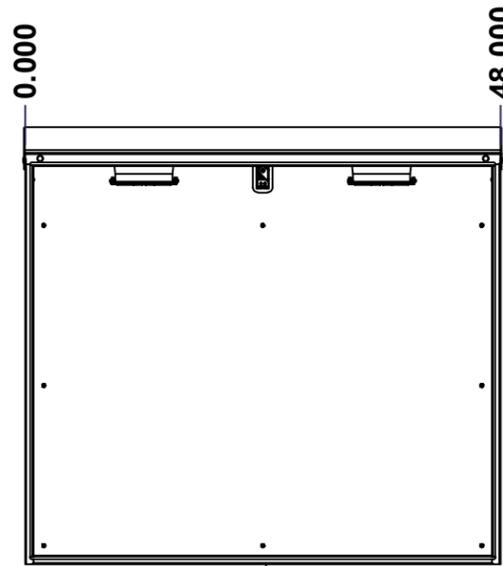

FRONT

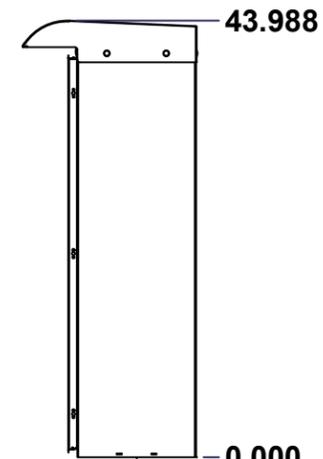

RIGHT

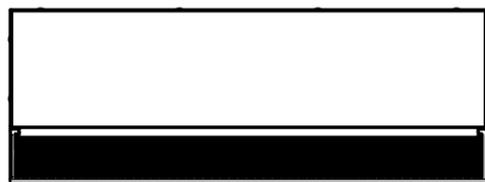

BOTTOM

No.	Revisions	Date	By/Par

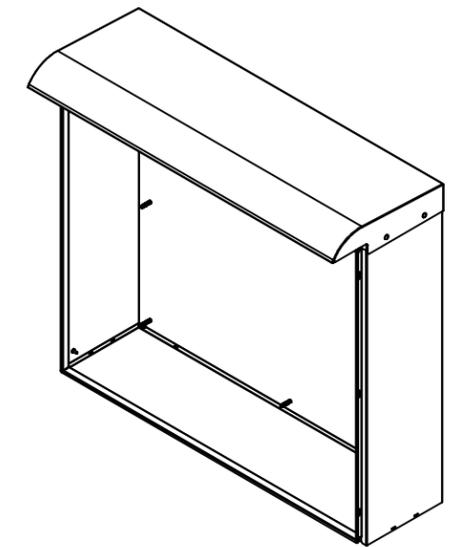

Isometric View



Tél: (450) 979-4373  
 Fax: (450) 979-4626  
[www.exmweb.com](http://www.exmweb.com)

Flatness  
Aplatissement

Max 3.0mm

Projection

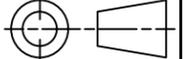

Customer Client	Date
Drawn By Dessiné Par BoxCad: BoxCad	Date 03-Sep-20
Material Matière 14 Ga Cold Rolled A1008 CS Type B (1.7mm)	

Color Couleur White RAL9003	Finish Fini Rough Textured
--------------------------------	-------------------------------

Description 5300EWBDD 41" x 48" x 12" Body	Detail Rev.
---	-------------

Part Number Numéro Pièce 5300EWBDD414812B	Rev. 0	3
--	--------	---

SEE BILL OF MATERIAL ON LAST PAGE

This drawing is confidential and must not be reproduced or used without the consent of EXM

Ce dessin est confidentiel et ne doit pas être reproduit ou utilisé sans le consentement de EXM

STANDARD FEATURES ARE NOT LISTED IN THIS HOLE TABLE			
HOLE TABLE - RIGHT VIEW (CUSTOM FEATURE ONLY)			
CUT-OUT	XDIM	YDIM	DESCRIPTION
1	10.500	2.000	GND STUD M6 x 16mm (Inside)

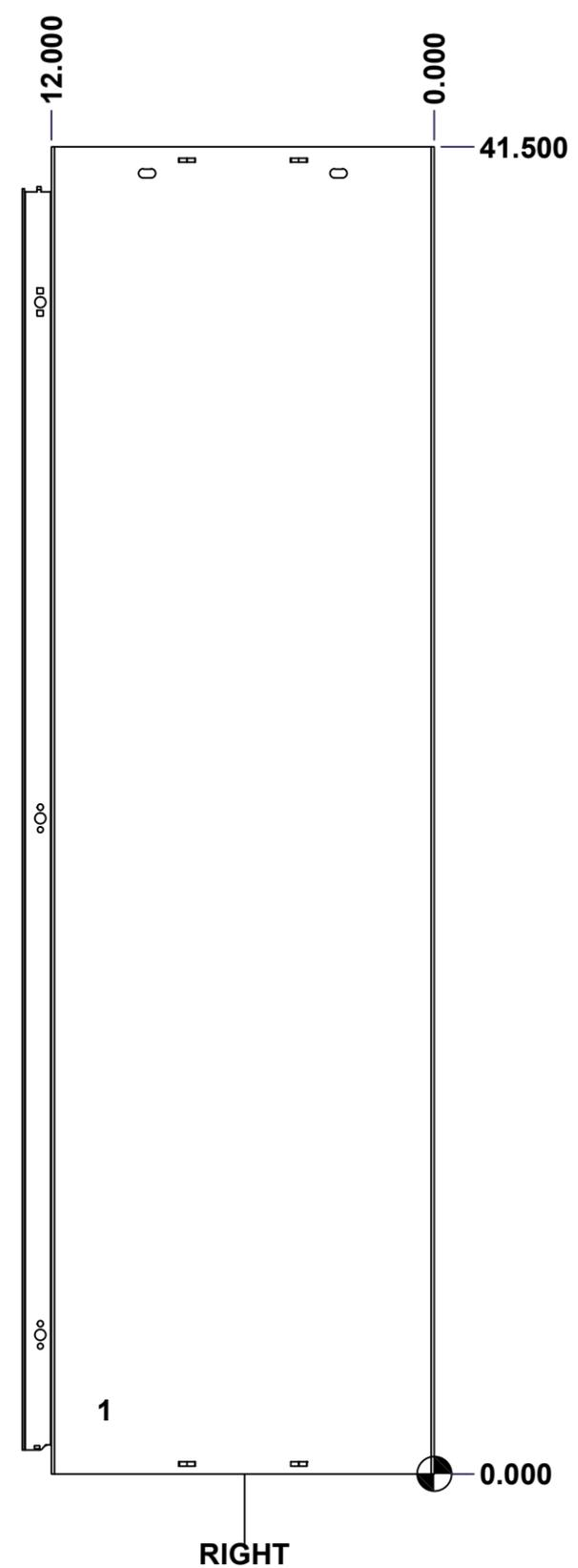

	Description	Status	
	5300EWBDD 41" x 48" x 12" Body	(NULL)	
	Part Number Numéro Pièce	Rev.	
	<b>5300EWBDD414812B</b>	<b>0</b>	4 13

This drawing is confidential and must not be reproduced or used without the consent of EXM

Ce dessin est confidentiel et ne doit pas être reproduit ou utilisé sans le consentement de EXM

STANDARD FEATURES ARE NOT LISTED IN THIS HOLE TABLE			
HOLE TABLE - LEFT VIEW (CUSTOM FEATURE ONLY)			
CUT-OUT	XDIM	YDIM	DESCRIPTION
1	10.500	2.000	GND STUD M6 x 16mm (Inside)

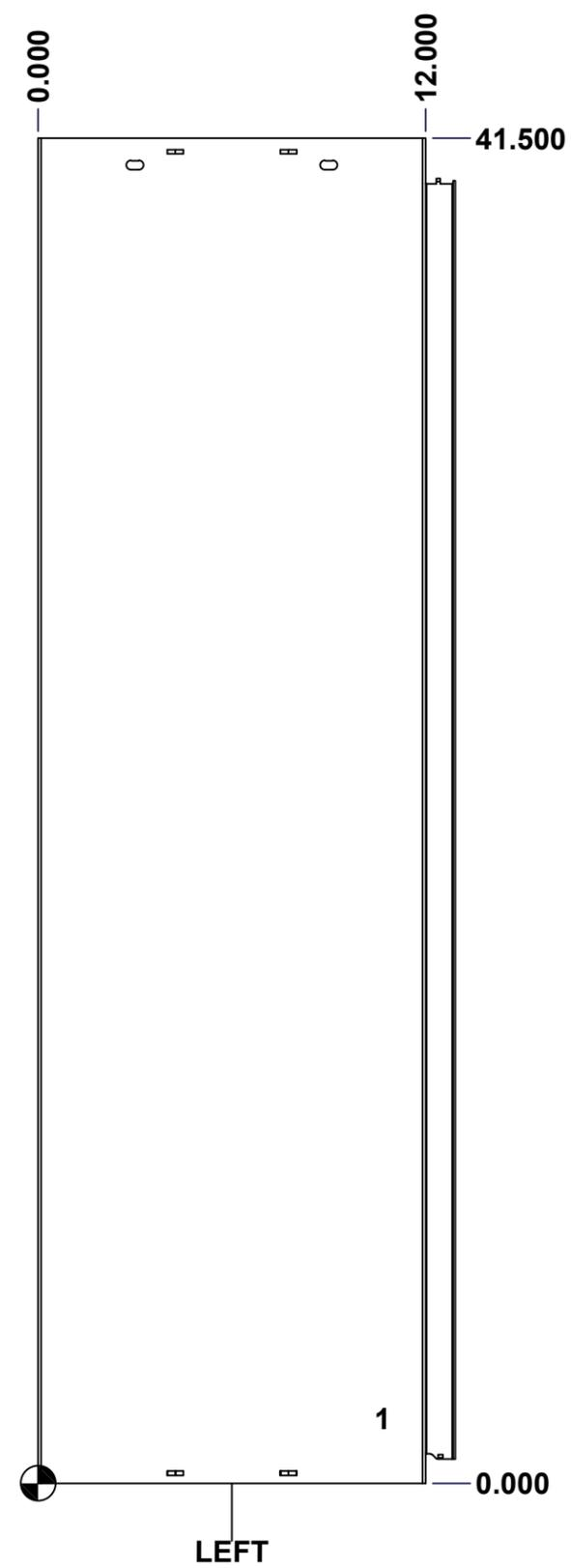

	Description	Status
	5300EWBDD 41" x 48" x 12" Body	(NULL)
	Part Number Numéro Pièce	Rev.
	<b>5300EWBDD414812B</b>	<b>0</b> / 5
		13

This drawing is confidential and must not be reproduced or used without the consent of EXM

Ce dessin est confidentiel et ne doit pas être reproduit ou utilisé sans le consentement de EXM

**STANDARD FEATURES ARE NOT LISTED IN THIS HOLE TABLE**

**HOLE TABLE - BACK VIEW (CUSTOM FEATURE ONLY)**

CUT-OUT	XDIM	YDIM	DESCRIPTION
1	1.875	1.875	IP STUD M8 x 35mm (Inside)
2	1.875	34.125	IP STUD M8 x 35mm (Inside)
3	46.125	34.125	IP STUD M8 x 35mm (Inside)
4	46.125	1.875	IP STUD M8 x 35mm (Inside)
5	1.875	18.000	IP STUD M8 x 35mm (Inside)
6	46.125	18.000	IP STUD M8 x 35mm (Inside)
7	24.000	1.875	IP STUD M8 x 35mm (Inside)
8	24.000	34.125	IP STUD M8 x 35mm (Inside)
-----			
9	47.250	0.750	RND Ø0.390
10	47.250	38.750	RND Ø0.390
11	0.750	38.750	RND Ø0.390
12	0.750	0.750	RND Ø0.390

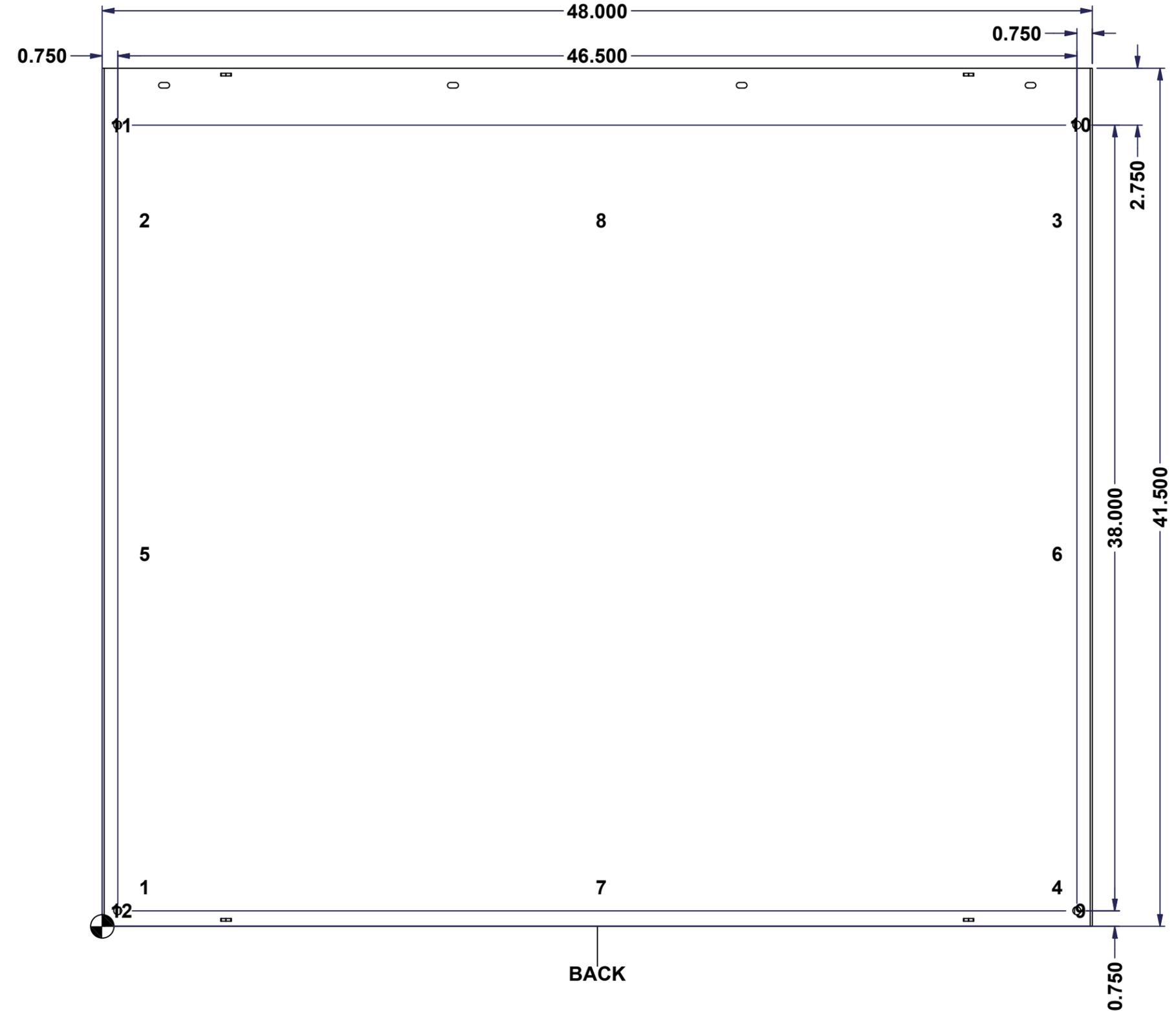

	Description	Status
	5300EWBDD 41" x 48" x 12" Body	(NULL)
	Part Number	Rev.
	Numéro Pièce <b>5300EWBDD414812B</b>	<b>0</b> / 6
		13

This drawing is confidential and must not be reproduced or used without the consent of EXM

Ce dessin est confidentiel et ne doit pas être reproduit ou utilisé sans le consentement de EXM

No.	Revisions	Date	By/Par

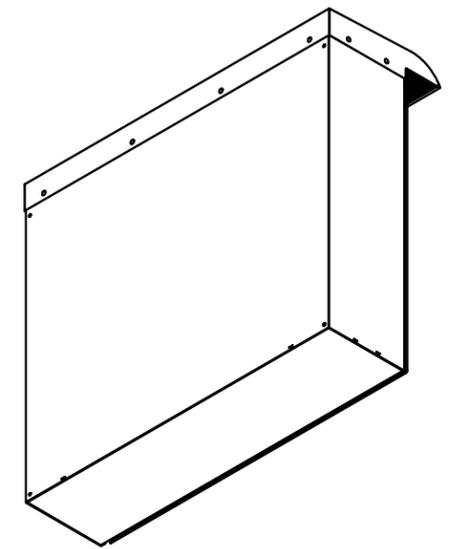

Isometric View



2	STK-Q-16080	0	Ground Stud M6 x 16mm Steel
1	STK-P-04752	0	Epoxy Primer Gray Powdura EAS6-C0000 (Bottom Layer)
1	STK-P-02401R	0	Powder Paint (White / Rough Textured)
1	01141.9-00	0	Small Thermostat (°F Normally Open)
2	STK-Q-05020	5	M5 x 8mm Thread Rolling Screw
1	5300EWBDD414812TH-P	0	5300EWBDD Thermostat Support Part
2	880FP325-239-115	5	Filter Fan - 325mm x 325mm (239CFM)
1	5300EWBDD414812GP-P	0	5300EWBDD 41" x 48" x 12" Fan Gland Plate Part
10	STK-Q-07220	1	M6 Nylon Insert Lock Nut
10	STK-Q-00260	1	M6 x 13mm Carriage Bolt
1	5300EWBDD414812T-P	0	5300EWBDD 48" x 12" Top Part
8	STK-Q-16005	1	Stud M8 x 35 (No Paint Cap Required)
1	5300EWBDD414812BT-P	0	5300EWBDD 41" x 48" x 12" Bottom Part
1	5300EWBDD414812F-P	0	5300EWBDD 41" x 48" x 12" Front Part
1	5300EWBDD414812B-P	0	5300EWBDD 41" x 48" x 12" Body Part

Qty	Part Number	Rev	Description
Parts List			

Tél: (450) 979-4373 Fax: (450) 979-4626 <a href="http://www.exmweb.com">www.exmweb.com</a>	Flatness Aplatissement	Max 3.0mm
	Projection	
Customer Client	Date	
Drawn By Dessiné Par	BoxCad: BoxCad	Date 03-Sep-20
Material Matière	14 Ga Cold Rolled A1008 CS Type B (1.7mm)	
Color Couleur	White RAL9003	Finish Fini
Description		Detail Rev.
5300EWBDD 41" x 48" x 12" Body		
Part Number Numéro Pièce	Rev.	7
<b>5300EWBDD414812B</b>	<b>0</b>	13

This drawing is confidential and must not be reproduced or used without the consent of EXM

Ce dessin est confidentiel et ne doit pas être reproduit ou utilisé sans le consentement de EXM

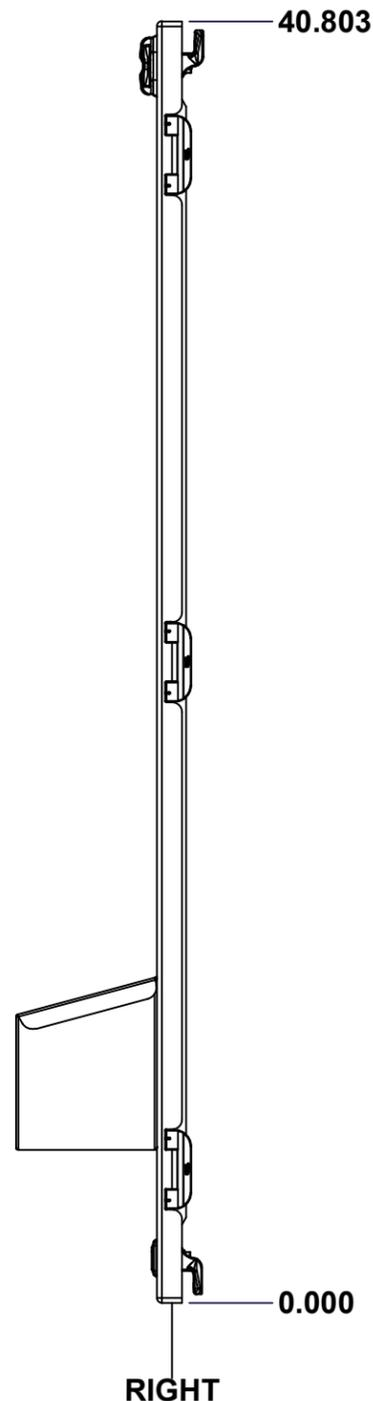
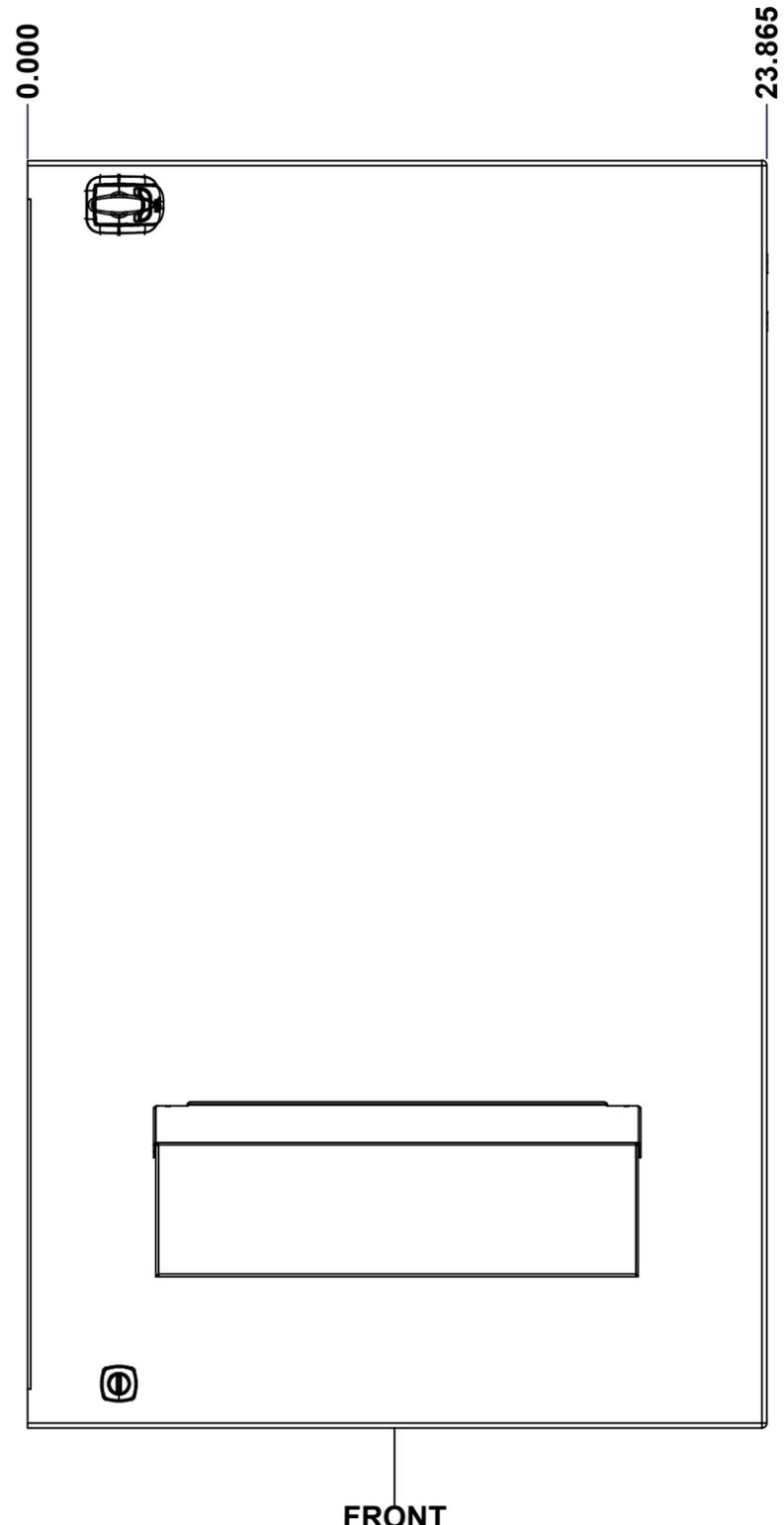
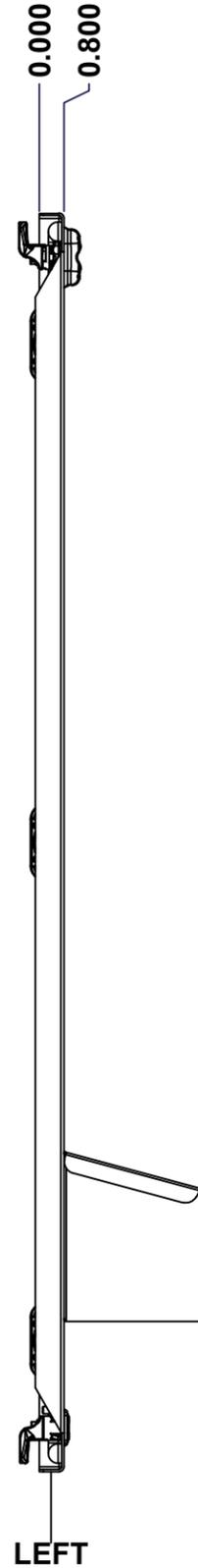
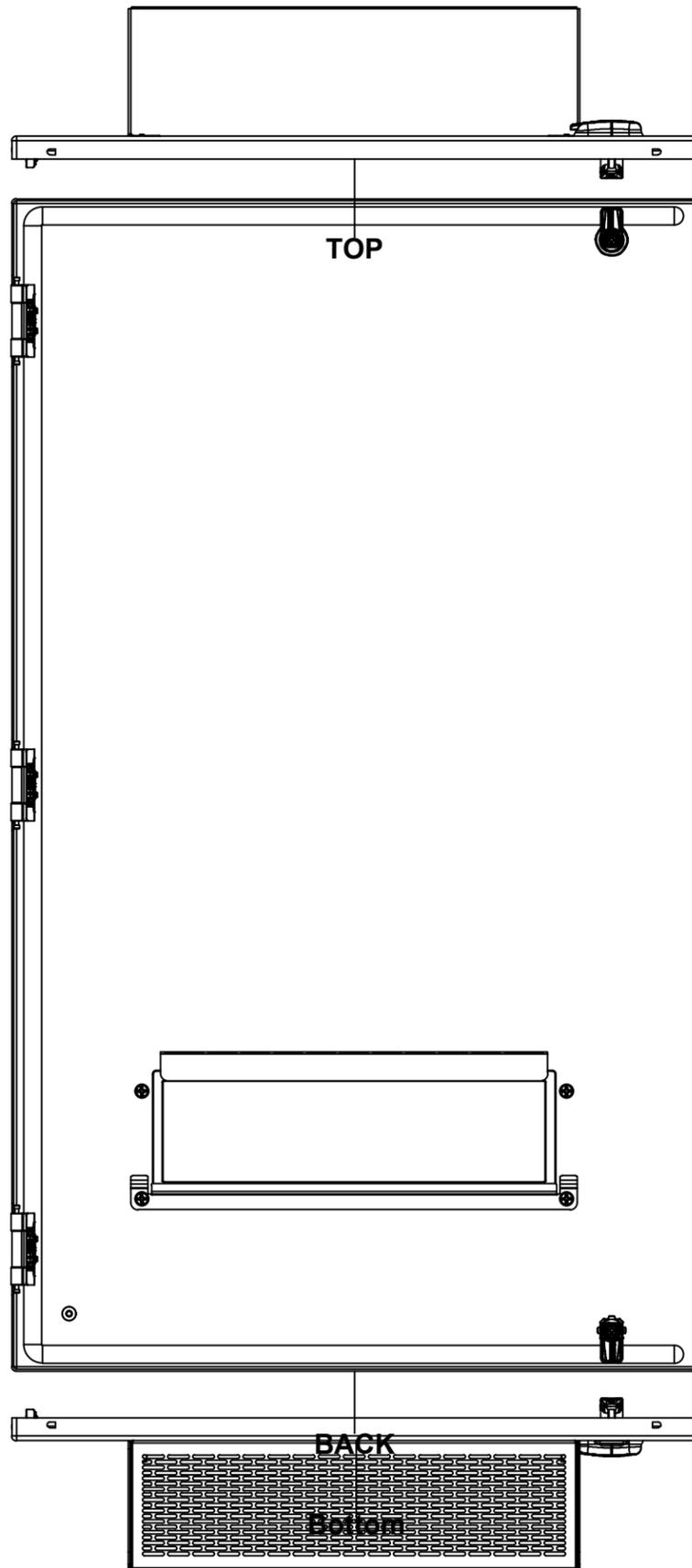

No.	Revisions	Date	By/Par

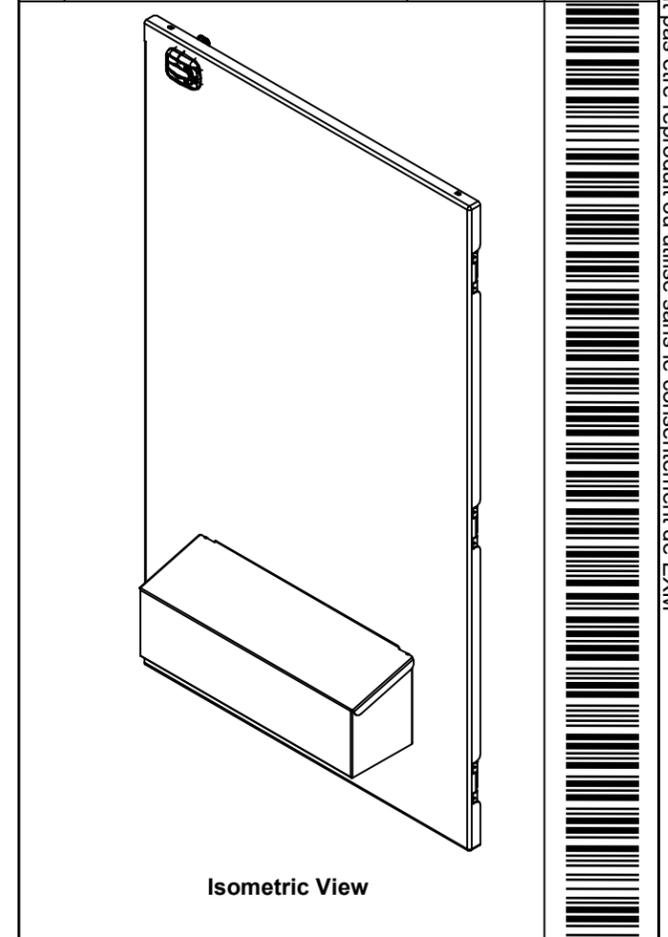

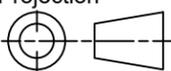
 Tél: (450) 979-4373 Fax: (450) 979-4626 <a href="http://www.exmweb.com">www.exmweb.com</a>	Flatness Aplatissement Max 3.0mm
	Projection 
Customer Client	Date
Drawn By Dessiné Par BoxCad: BoxCad	Date 03-Sep-20
Material Matière 14 Ga Cold Rolled A1008 CS Type B (1.7mm)	
Color Couleur White RAL9003	Finish Fini Rough Textured
Description	
5300EWBDD 41" x 48" x 12" Lock Door	
Part Number Numéro Pièce	Rev. 8 0
SEE BILL OF MATERIAL ON LAST PAGE <b>5300EWBDD414812LD</b>	

SEE BILL OF MATERIAL ON LAST PAGE

**5300EWBDD414812LD**

Rev. 8  
0

This drawing is confidential and must not be reproduced or used without the consent of EXM

Ce dessin est confidentiel et ne doit pas être reproduit ou utilisé sans le consentement de EXM

**STANDARD FEATURES ARE NOT LISTED IN THIS HOLE TABLE**

**HOLE TABLE - FRONT VIEW (CUSTOM FEATURE ONLY)**

CUT-OUT	XDIM	YDIM	DESCRIPTION
1	2.000	2.000	GND STUD M6 x 16mm (Inside)
2	20.913	39.378	LOCK 880 SCQ4PL-SL @ 90.0°
3	20.913	1.425	LOCK 880 SCQ4-SL @ 270.0°

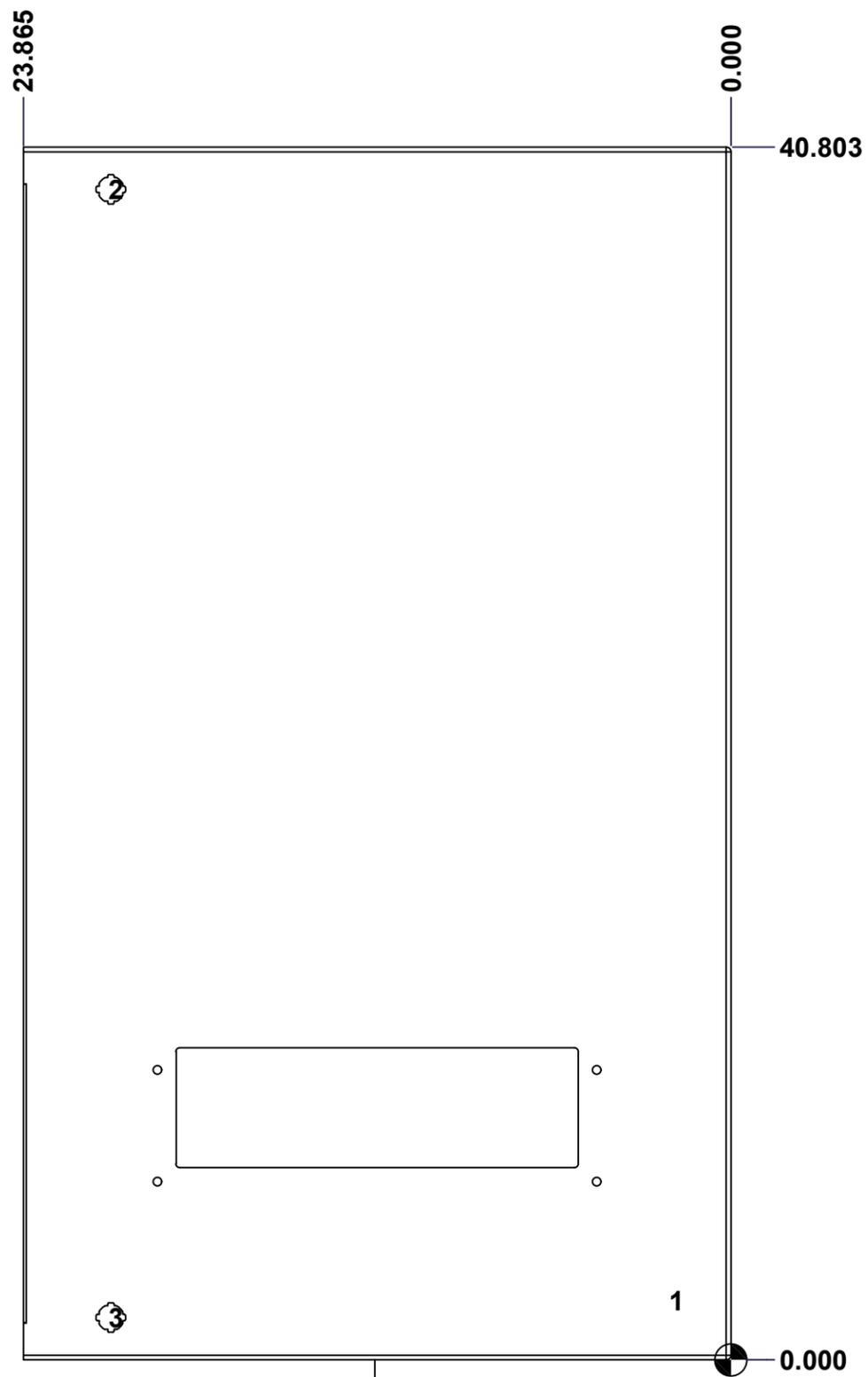

FRONT

	Description	Status
	5300EWBDD 41" x 48" LD	(NULL)
	Part Number Numéro Pièce	Rev.
	<b>5300EWBDD414812LD</b>	<b>0</b>
		9
		13

This drawing is confidential and must not be reproduced or used without the consent of EXM

Ce dessin est confidentiel et ne doit pas être reproduit ou utilisé sans le consentement de EXM

No.	Revisions	Date	By/Par

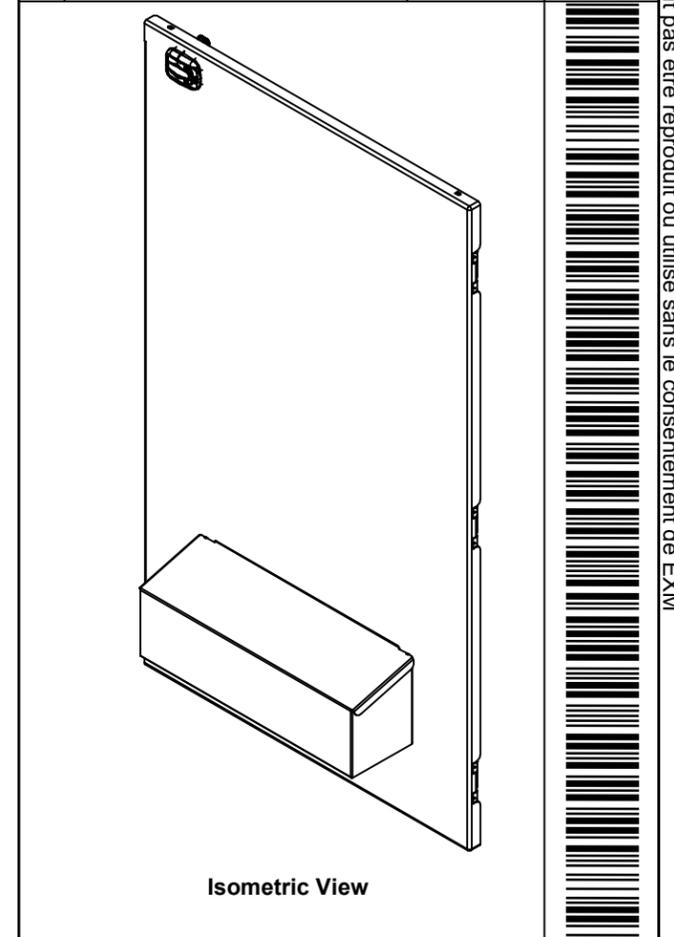

**EXM**  
www.exmweb.com

Tél: (450) 979-4373  
Fax: (450) 979-4626

Flatness  
Aplatissement  
Max 3.0mm

Projection

1	STK-P-02401R	0	Powder Paint (White / Rough Textured)
1	5300EWBDD414812LD-G	0	5300EWBDD 41" x 48" Lock Door Gasket
1	5300EWBDD414812LPF	0	Filter 14.062" x 4.250"
1	5300EWBDD414812FPH2 39	0	5300EWBDD 41" x 48" x 12" Rain Hood
1	STK-K-12500	16	5412 ES 1/4 Turn Lock
1	880 SCQ4PL-SL	3	5412 ES Padlockable 1/4 Turn Lock
1	STK-Q-16080	0	Ground Stud M6 x 16mm Steel
1	STK-P-04752	0	Epoxy Primer Gray Powdura EAS6-C0000 (Bottom Layer)
3	STK-K-09800	10	5412 ES Hinge with 2 Captive Hinge Pins
1	5300EWBDD414812LD-P	0	5300EWBDD 41" x 48" Lock Door

Customer Client	Date
Drawn By Dessiné Par BoxCad: BoxCad	Date 03-Sep-20
Material Matière 14 Ga Cold Rolled A1008 CS Type B (1.7mm)	
Color Couleur White RAL9003	Finish Fini Rough Textured
Description 5300EWBDD 41" x 48" x 12" Lock Door	Detail Rev.
Part Number Numéro Pièce <b>5300EWBDD414812LD</b>	Rev. 10 <b>0</b>

Qty	Part Name	Rev	Description
Parts List			

This drawing is confidential and must not be reproduced or used without the consent of EXM

Ce dessin est confidentiel et ne doit pas être reproduit ou utilisé sans le consentement de EXM

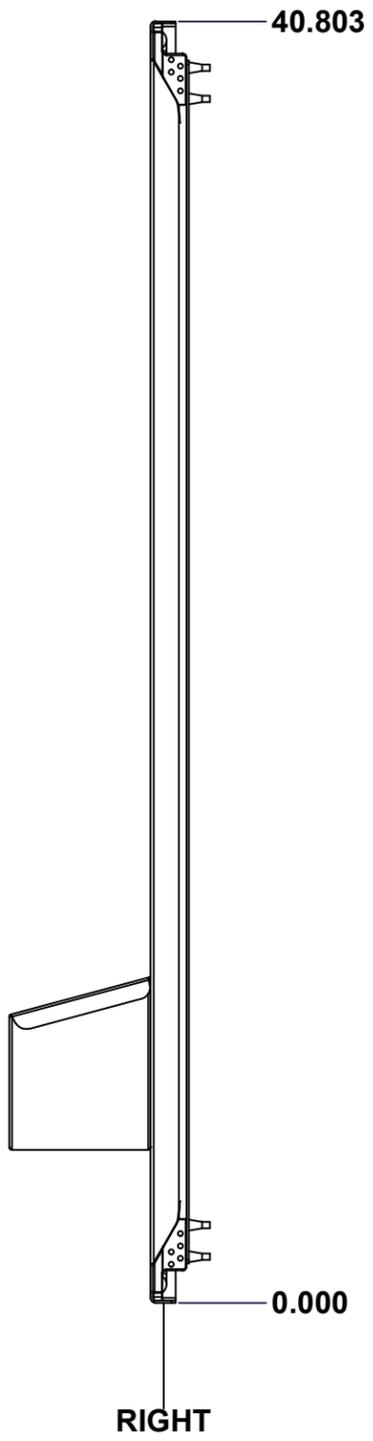
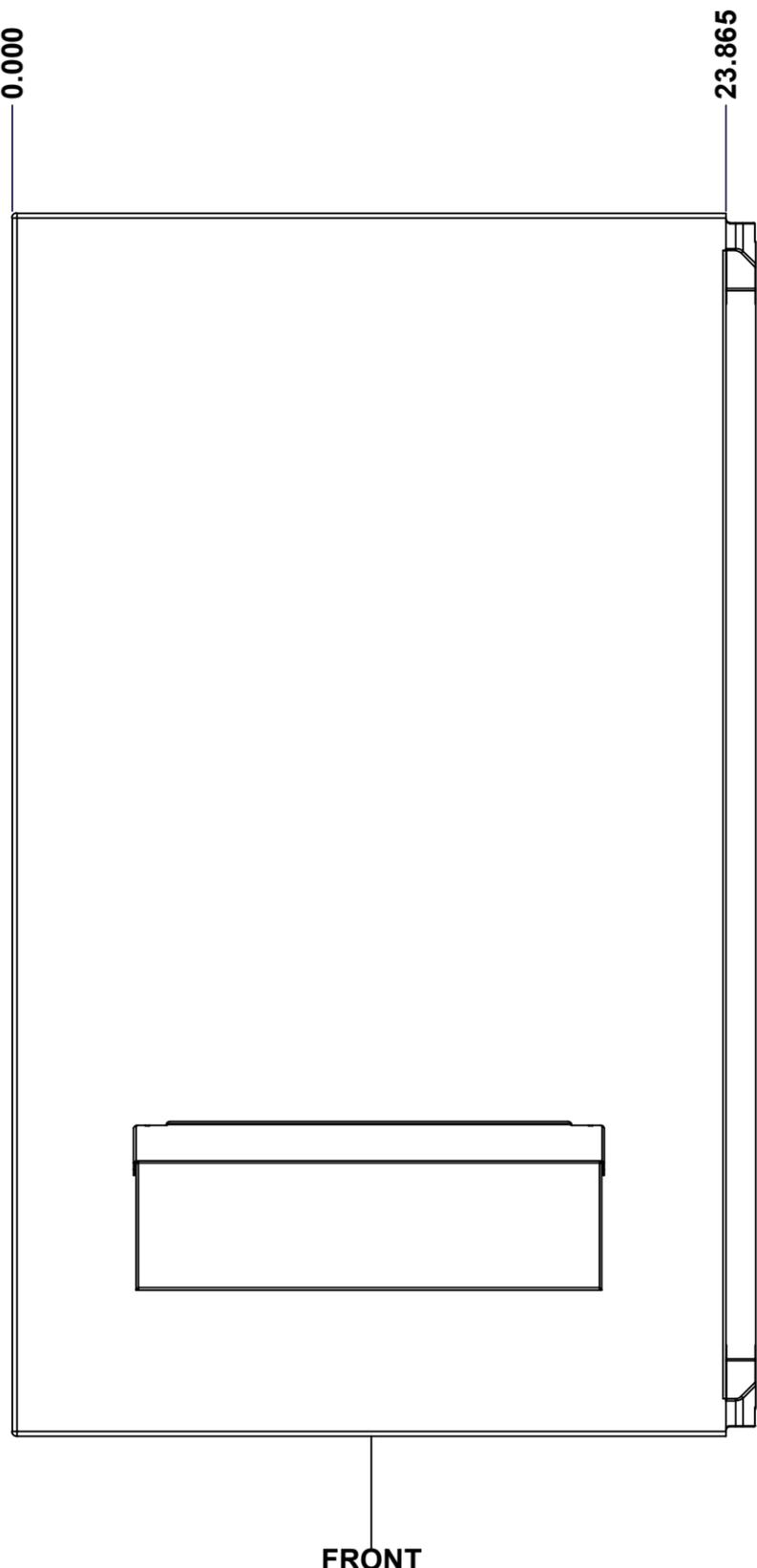
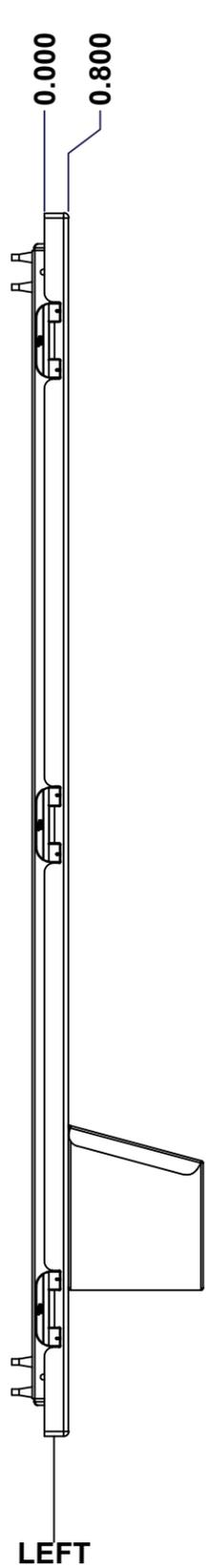
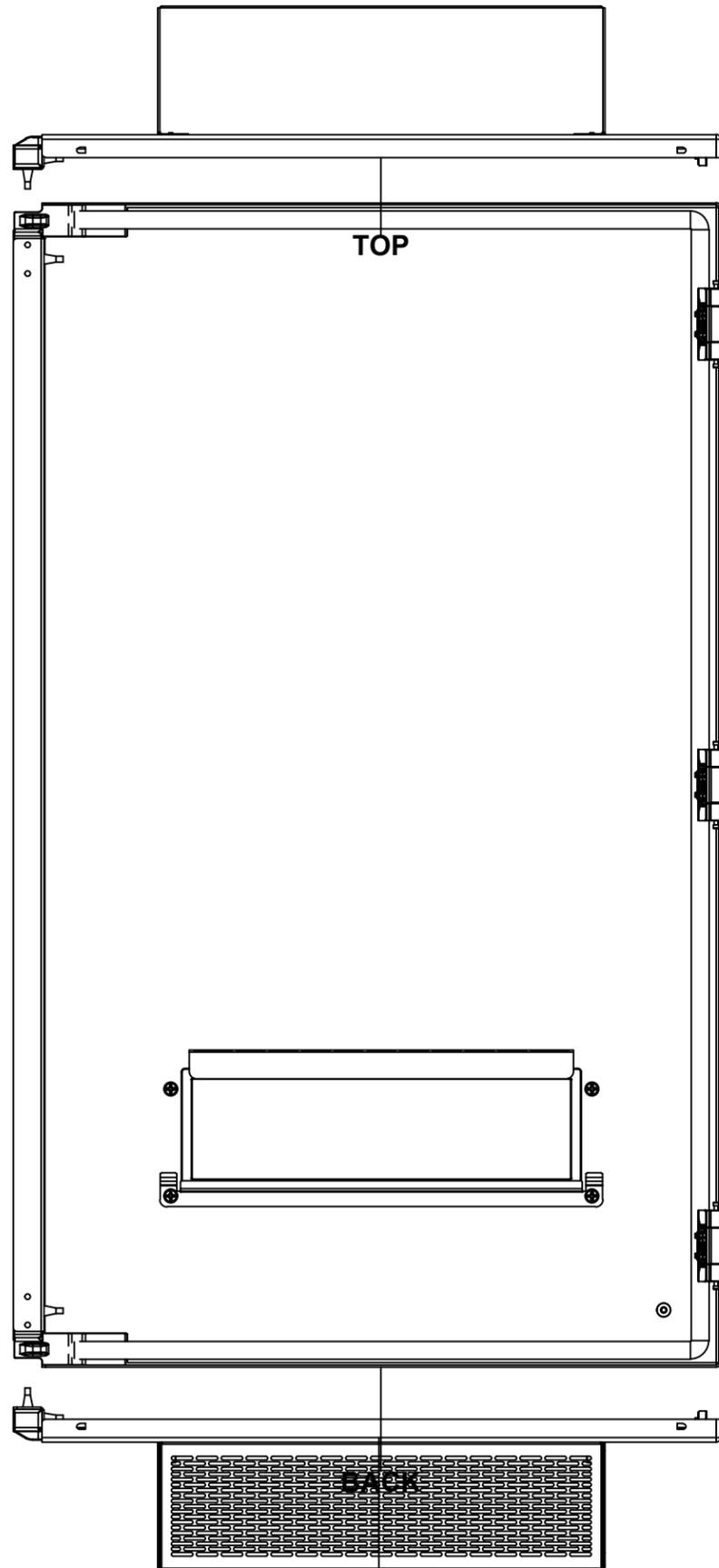

No.	Revisions	Date	By/Par

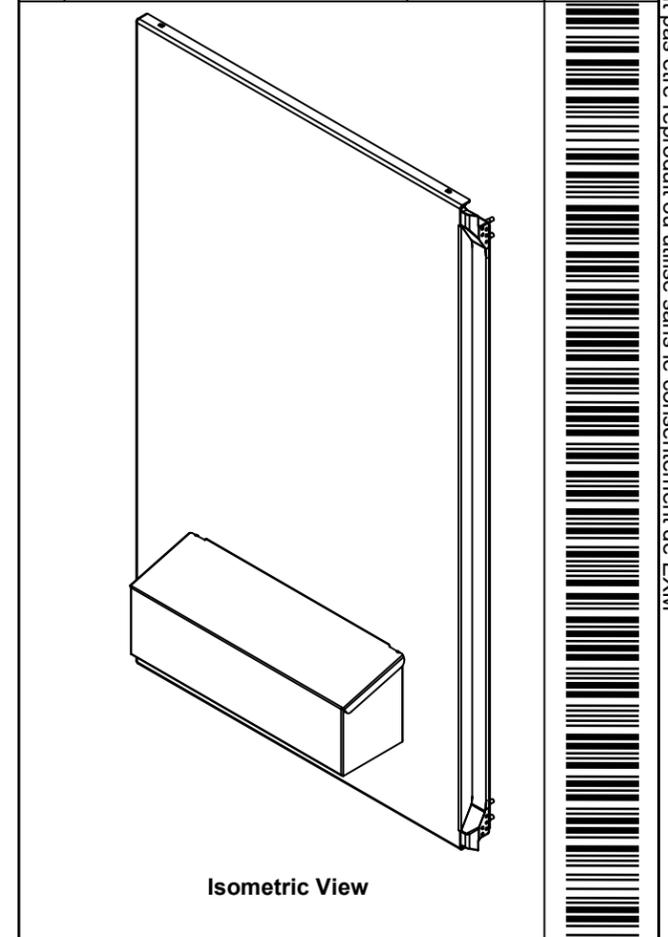

 Tél: (450) 979-4373 Fax: (450) 979-4626 <a href="http://www.exmweb.com">www.exmweb.com</a>		Flatness Aplatissement	
		Max 3.0mm	
Customer Client		Date	
Drawn By Dessiné Par BoxCad: BoxCad		Date 03-Sep-20	
Material Matière 14 Ga Cold Rolled A1008 CS Type B (1.7mm)			
Color Couleur White RAL9003		Finish Fini Rough Textured	
Description 5300EWBDD 41" x 48" x 12" Flang Door			Detail Rev.
Part Number Numéro Pièce <b>5300EWBDD414812FD</b>		Rev. <b>0</b>	11 13

SEE BILL OF MATERIAL ON LAST PAGE

This drawing is confidential and must not be reproduced or used without the consent of EXM

Ce dessin est confidentiel et ne doit pas être reproduit ou utilisé sans le consentement de EXM

STANDARD FEATURES ARE NOT LISTED IN THIS HOLE TABLE			
HOLE TABLE - FRONT VIEW (CUSTOM FEATURE ONLY)			
CUT-OUT	XDIM	YDIM	DESCRIPTION
1	2.000	2.000	GND STUD M6 x 16mm (Inside)

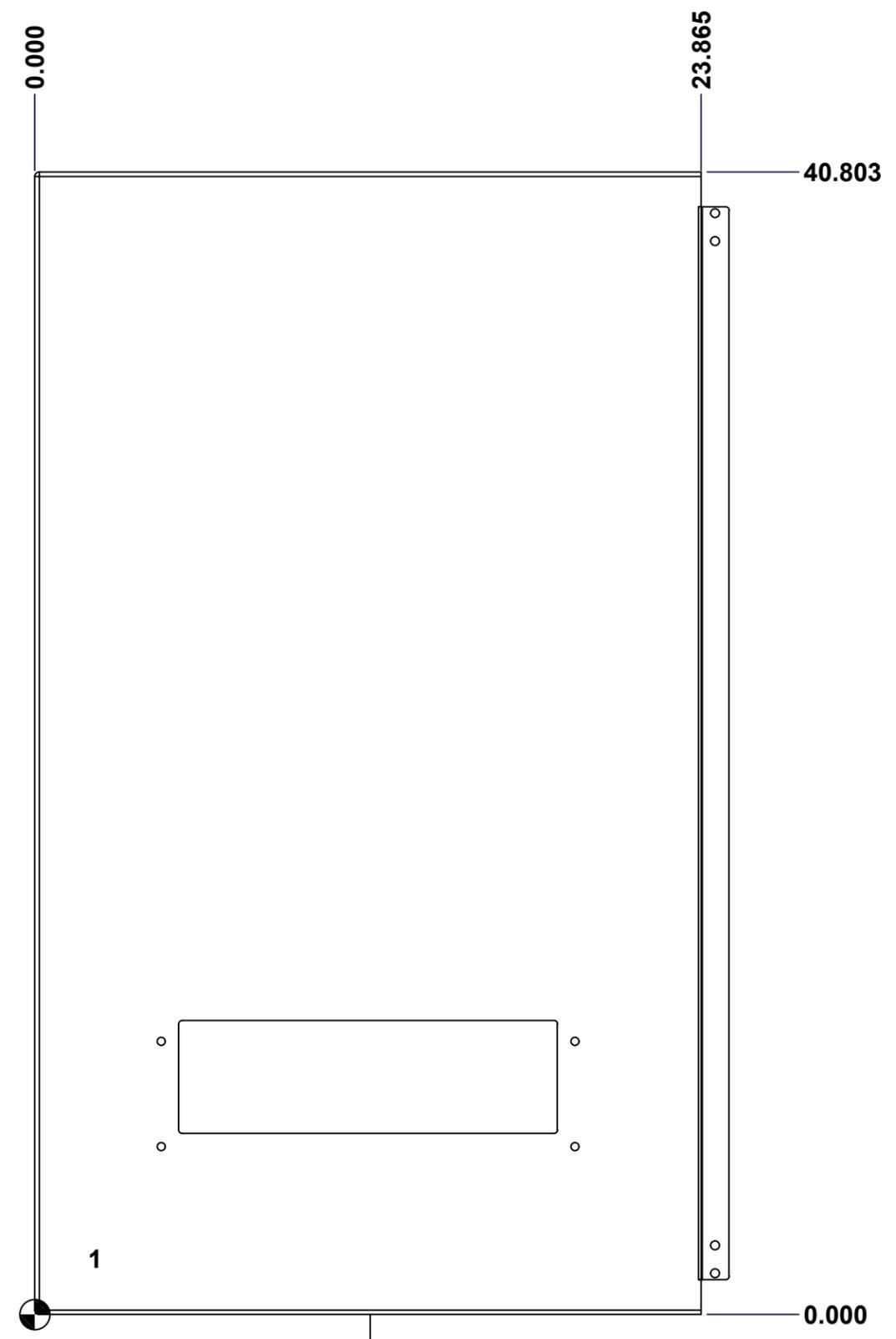

FRONT

	Description	Status
	5300EWBDD 41" x 48" Flange Door	(NULL)
	Part Number Numéro Pièce	Rev.
	<b>5300EWBDD414812FD</b>	<b>0</b>
		12
		13

This drawing is confidential and must not be reproduced or used without the consent of EXM

Ce dessin est confidentiel et ne doit pas être reproduit ou utilisé sans le consentement de EXM

No.	Revisions	Date	By/Par

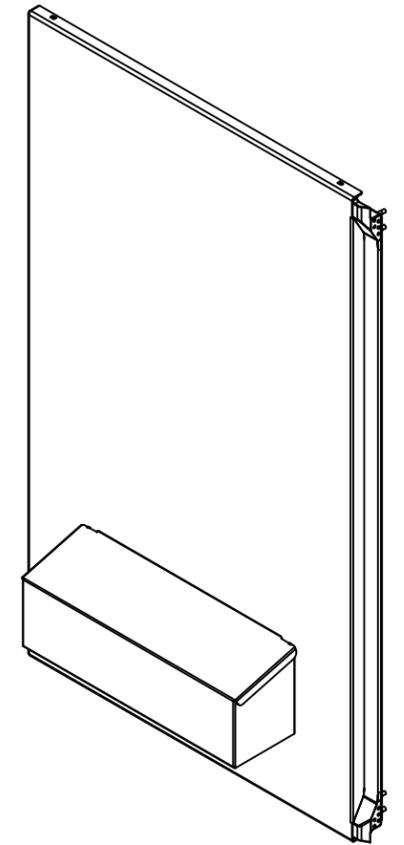

Isometric View

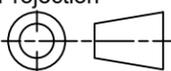

Qty	Part Name	Rev	Description
1	STK-Q-16080	0	Ground Stud M6 x 16mm Steel
1	5300EWBDD414812LPF	0	Filter 14.062" x 4.250"
1	5300EWBDD414812FPH239	0	5300EWBDD 41" x 48" x 12" Rain Hood
1	5300EWBDD414812FD-G	0	5300EWBDD 41" x 48" Flange Door Gasket
1	STK-G-00701	0	1" x 1/4" Self-Adhesive Neoprene Gasket
1	STK-P-04752	0	Epoxy Primer Gray Powdura EAS6-C0000 (Bottom Layer)
1	STK-P-02401R	0	Powder Paint (White / Rough Textured)
1	STK-G-03200	7	5500 ESDD Lower Flange Door Gasket
1	STK-G-03100	7	5500 ESDD Upper Flange Door Gasket
3	STK-K-09800	10	5412 ES Hinge with 2 Captive Hinge Pins
1	5300EWBDD414812FD-P	0	5300EWBDD 41" x 48" Flange Door Part

 Tél: (450) 979-4373 Fax: (450) 979-4626 <a href="http://www.exmweb.com">www.exmweb.com</a>		Flatness Aplatissement Max 3.0mm Projection 
Customer Client	Date	
Drawn By Dessiné Par	BoxCad: BoxCad	Date 03-Sep-20
Material Matière	14 Ga Cold Rolled A1008 CS Type B (1.7mm)	
Color Couleur	White RAL9003	Finish Fini Rough Textured
Description		Detail Rev.
5300EWBDD 41" x 48" x 12" Flang Door		
Part Number Numéro Pièce	Rev.	13
<b>5300EWBDD414812FD</b>	<b>0</b>	13

Parts List