

This drawing is confidential and must not be reproduced or used without the consent of EXM

Ce dessin est confidentiel et ne doit pas être reproduit ou utilisé sans le consentement de EXM

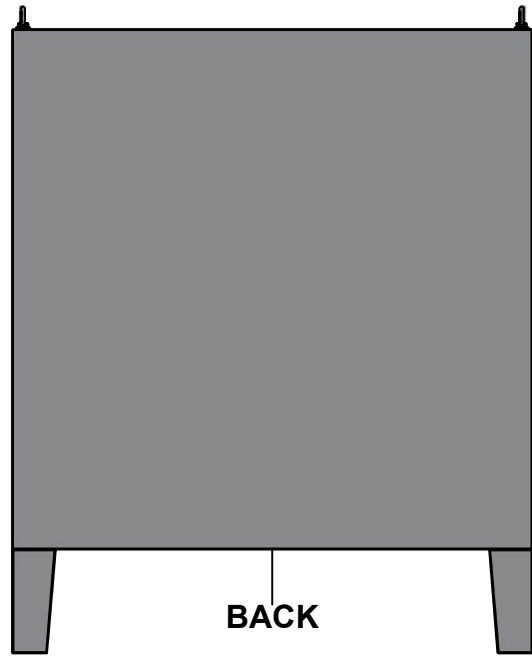

TOP



BACK

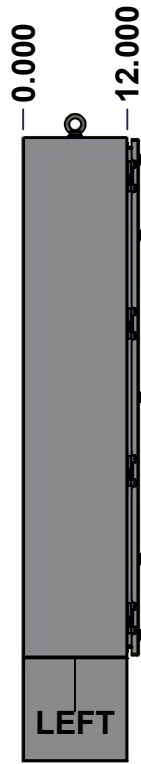

LEFT

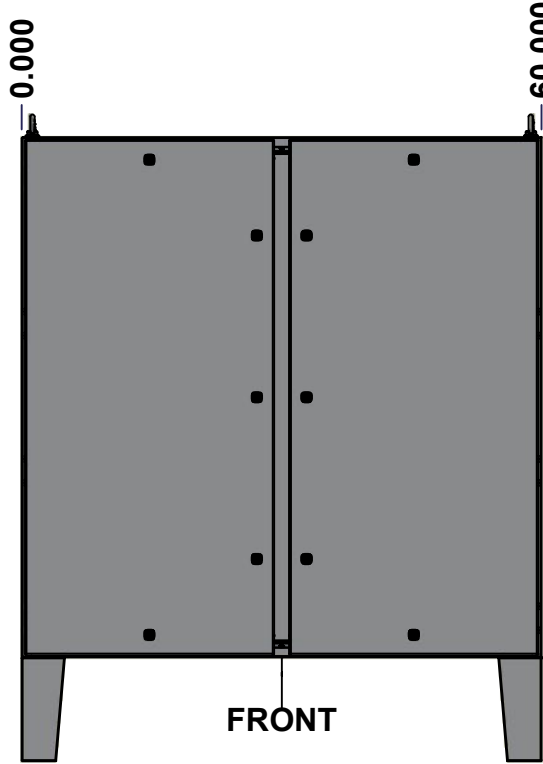

FRONT

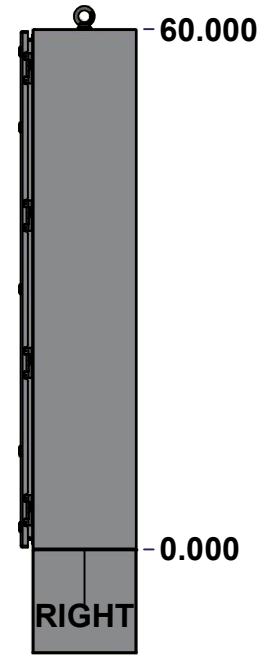

RIGHT



BOTTOM

No.	Revisions	Date	By/Par

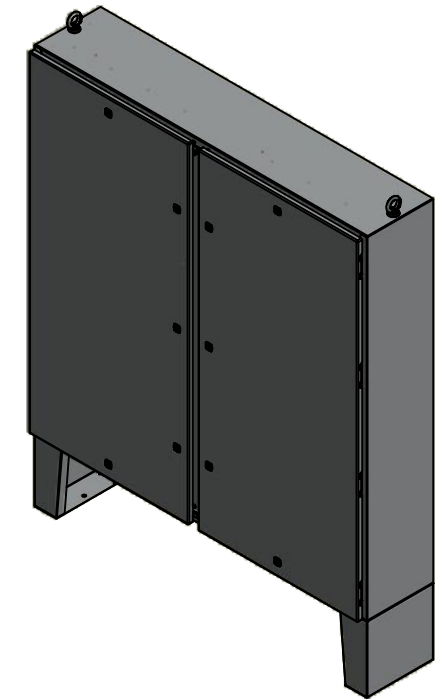

Isometric View



Tél: (450) 979-4373  
 Fax: (450) 979-4626  
[www.exmweb.com](http://www.exmweb.com)

Flatness  
Aplatissement

Max 3.0mm

Projection



Customer Client	Date
Drawn By / Dessiné Par: BoxCad: BoxCad	Date: 18-Sep-14

Material / Matière: 12 Ga Cold Rolled A1008 CS Type B (2.5mm)

Color / Couleur: Asa-61 Grey	Finish / Fini: Smooth
------------------------------	-----------------------

Description: 5412DDS 60" x 60" x 12" Assembly

Part Number / Numéro Pièce: 5412DDS606012	Rev. 0	1
---	--------	---

SEE BILL OF MATERIAL ON LAST PAGE

This drawing is confidential and must not be reproduced or used without the consent of EXM

Ce dessin est confidentiel et ne doit pas être reproduit ou utilisé sans le consentement de EXM

NOTE	
ITEM	DESCRIPTION
1	NEMA 4/12 Enclosure
2	C/W Standard ground studs on box and cover
3	W/O Standard door stiffener
4	C/W Standard inner panel (Included)
5	C/W Standard inner panel mounting studs
6	C/W 880 PPL included (Not installed)
7	C/W Eyebolts
8	C/W Mounting feet sold separately (Installed)
9	C/W Struts installed (Included)
10	C/W Interlock Kit (Installed by EXM)

No.	Revisions	Date	By/Par

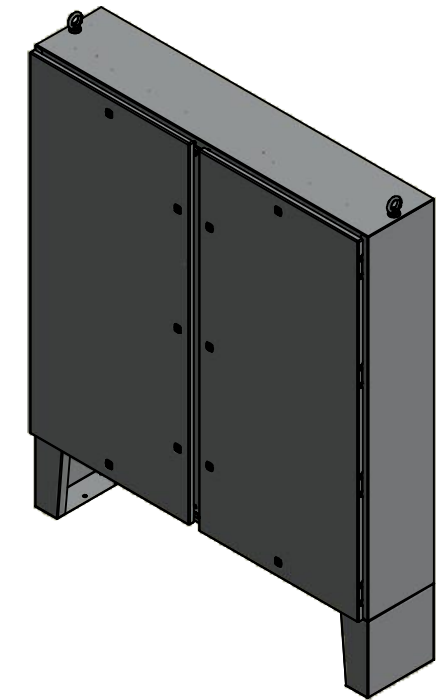

Isometric View

 Tél: (450) 979-4373  
 Fax: (450) 979-4626  
[www.exmweb.com](http://www.exmweb.com)

Flatness  
 Aplatissement  
 Max 3.0mm  
 Projection  

1	5412DDS606012MF	0	885 MFHD 12" x 12" Mounting Feet
1	880INTI	2	880 INTI - Interlock Post Kit
1	880EB14	2	Eye Bolt M14 (Pack of 2)
8	STK-Q-07320	0	Flange Lock Nut M10
1	885SP6060G	0	885 SP6060G Inner Panel
8	STK-Q-07620	0	M10 Plastic Spacer 0.875"
1	5412DDS606012FD	0	5412DDS 60" x 60" Master Door
1	5412DDS606012LD	0	5412DDS 60" x 60" Slave Door
1	5412DDS606012B	0	5412DDS 60" x 60" x 12" Body
2	5412DDS606012GP	0	5412DDS Gland Plate
8	STK-Q-04050-10	8	M6 x 10mm Hexagon Socket Head Machine Screw with Nyseal
Qty	Part Number	Rev	Description
Parts List			

PACKING		
ITEM	QTY	DESCRIPTION
Cardboard sleeve	2	Top and Bottom
Cardboard strip	2	Between back of enclosure and inner panel
Plastic bag	1	To protect cover surface and inside gasket
Cardboard corner	4	To reinforced for the plastic strap tightening
Plastic strap - Black	2	To Squeeze 2 cardboard sleeve together
Packaging label	3	White label with PN
Plastic strap- Green	2	To secure the enclosure to the wood pallet
Wood Pallet	1	2" deeper and 3" larger than enclosure size

Customer Client

Drawn By Dessiné Par BoxCad: BoxCad

Material Matière 12 Ga Cold Rolled A1008 CS Type B (2.5mm)

Color Couleur Asa-61 Grey

Finish Fini Smooth

Description 5412DDS 60" x 60" x 12" Assembly

Part Number Numéro Pièce **5412DDS606012**

Date 18-Sep-14

Detail Rev. 0

Rev. 2

18

This drawing is confidential and must not be reproduced or used without the consent of EXM

Ce dessin est confidentiel et ne doit pas être reproduit ou utilisé sans le consentement de EXM



TOP



BACK

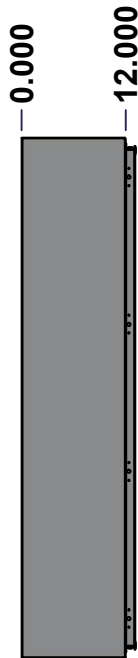

LEFT

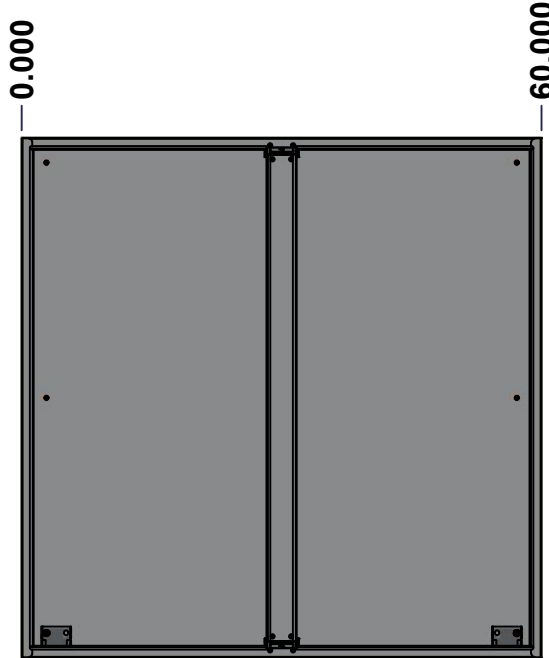

FRONT

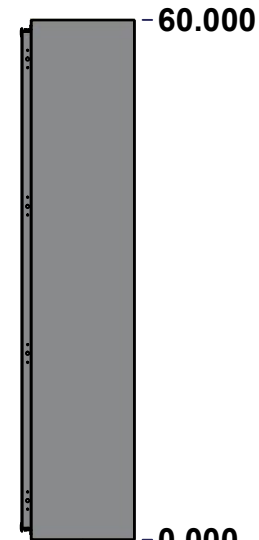

RIGHT



BOTTOM

No.	Revisions	Date	By/Par

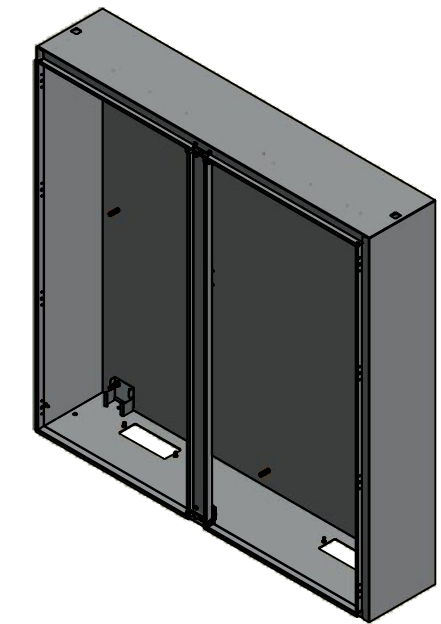

Isometric View

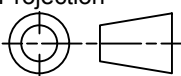

 Tél: (450) 979-4373 Fax: (450) 979-4626 <a href="http://www.exmweb.com">www.exmweb.com</a>		Flatness Aplatissement Max 3.0mm Projection 
Customer Client	Date	
Drawn By Dessiné Par	BoxCad: BoxCad	Date 18-Sep-14
Material Matière	12 Ga Cold Rolled A1008 CS Type B (2.5mm)	
Color Couleur	Asa-61 Grey	Finish Fini Smooth
Description	Detail Rev.	
5412DDS 60" x 60" x 12" Body		
Part Number Numéro Pièce	Rev. 3	18
5412DDS606012B		0

SEE BILL OF MATERIAL ON LAST PAGE

This drawing is confidential and must not be reproduced or used without the consent of EXM

Ce dessin est confidentiel et ne doit pas être reproduit ou utilisé sans le consentement de EXM

**STANDARD FEATURES ARE NOT LISTED IN THIS HOLE TABLE**

**HOLE TABLE - TOP VIEW (CUSTOM FEATURE ONLY)**

CUT-OUT	XDIM	YDIM	DESCRIPTION
1	44.911	7.911	Struts CR400 21.500" (Inside)
2	14.911	7.911	Struts CR400 21.500" (Inside)
3	44.911	7.911	STUDS M6 x 10mm (Inside)
4	37.161	7.911	STUDS M6 x 10mm (Inside)
5	52.661	7.911	STUDS M6 x 10mm (Inside)
6	14.911	7.911	STUDS M6 x 10mm (Inside)
7	7.161	7.911	STUDS M6 x 10mm (Inside)
8	22.661	7.911	STUDS M6 x 10mm (Inside)

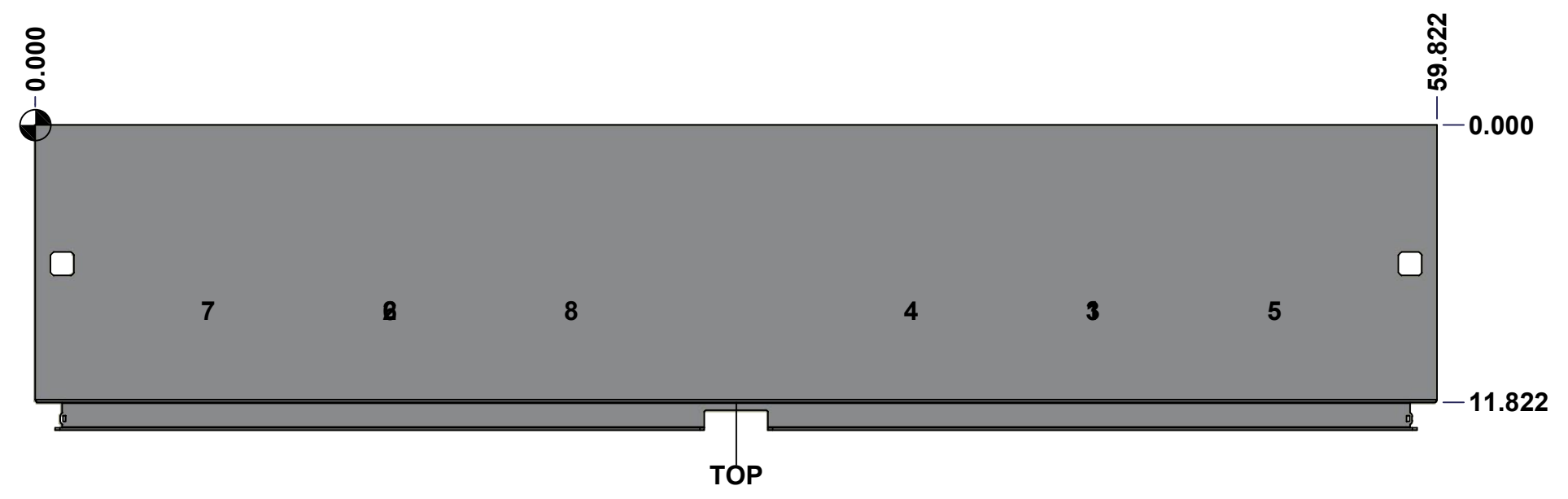

	Description	Status	
	5412DDS 60" x 60" x 12" Body	(NULL)	
	Part Number Numéro Pièce	Rev.	
	<b>5412DDS606012B</b>	<b>0</b>	4
			18

This drawing is confidential and must not be reproduced or used without the consent of EXM

Ce dessin est confidentiel et ne doit pas être reproduit ou utilisé sans le consentement de EXM

<b>STANDARD FEATURES ARE NOT LISTED IN THIS HOLE TABLE</b>			
<b>HOLE TABLE - RIGHT VIEW (CUSTOM FEATURE ONLY)</b>			
CUT-OUT	XDIM	YDIM	DESCRIPTION
1	10.411	3.286	GND STUD M6 x 16mm (Inside)

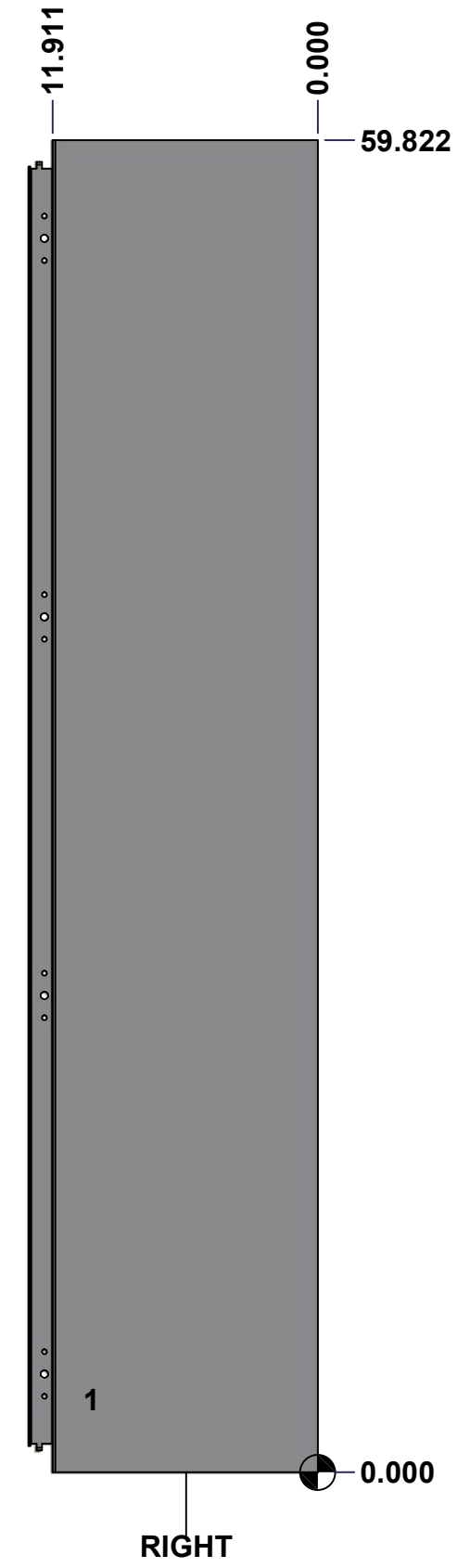

	Description	Status	
	5412DDS 60" x 60" x 12" Body	(NULL)	
	Part Number Numéro Pièce	Rev.	5
	<b>5412DDS606012B</b>	<b>0</b>	18

This drawing is confidential and must not be reproduced or used without the consent of EXM

Ce dessin est confidentiel et ne doit pas être reproduit ou utilisé sans le consentement de EXM

**STANDARD FEATURES ARE NOT LISTED IN THIS HOLE TABLE**

**HOLE TABLE - BOTTOM VIEW (CUSTOM FEATURE ONLY)**

CUT-OUT	XDIM	YDIM	DESCRIPTION
1	7.286	3.411	GP STUD M6 x 16mm (Inside)
2	16.536	3.411	GP STUD M6 x 16mm (Inside)
3	43.286	3.411	GP STUD M6 x 16mm (Inside)
4	52.536	3.411	GP STUD M6 x 16mm (Inside)
-----			
5	3.911	0.911	RND Ø0.500
6	0.911	5.911	RND Ø0.500
7	3.911	10.911	RND Ø0.500
8	55.911	0.911	RND Ø0.500
9	58.911	5.911	RND Ø0.500
10	55.911	10.911	RND Ø0.500

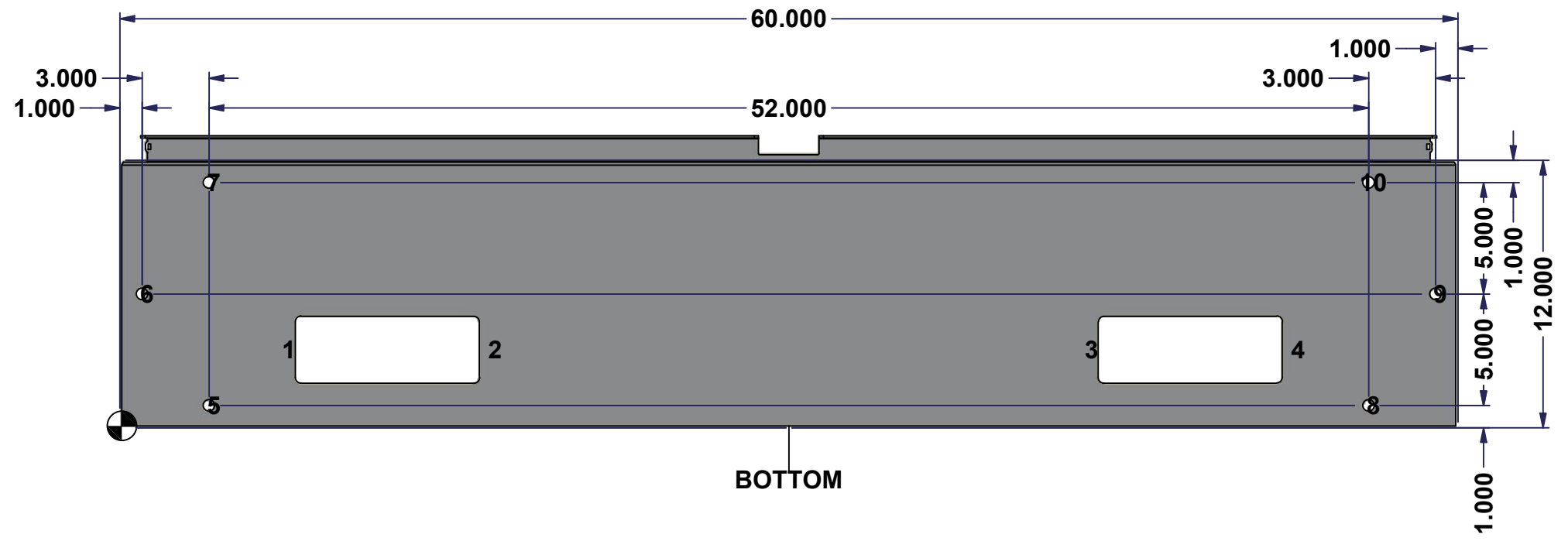

	Description	Status
	5412DDS 60" x 60" x 12" Body	(NULL)
	Part Number	Rev.
	Numéro Pièce	6
	<b>5412DDS606012B</b>	<b>0</b>
		18

This drawing is confidential and must not be reproduced or used without the consent of EXM

Ce dessin est confidentiel et ne doit pas être reproduit ou utilisé sans le consentement de EXM

STANDARD FEATURES ARE NOT LISTED IN THIS HOLE TABLE			
HOLE TABLE - LEFT VIEW (CUSTOM FEATURE ONLY)			
CUT-OUT	XDIM	YDIM	DESCRIPTION
1	10.411	3.286	GND STUD M6 x 16mm (Inside)

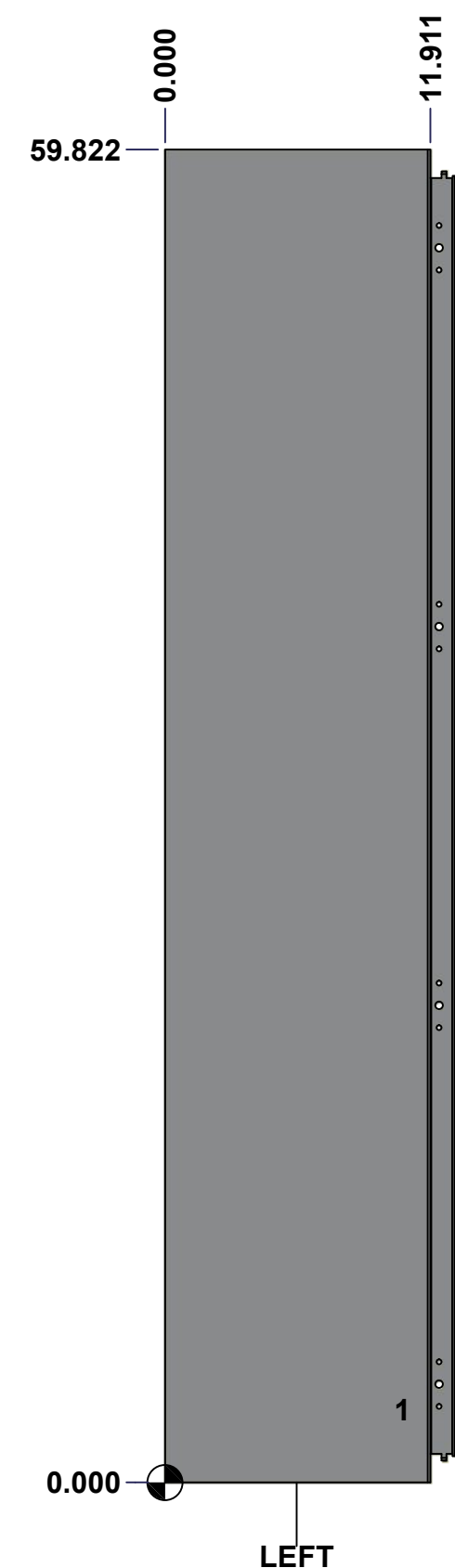

	Description	Status	
	5412DDS 60" x 60" x 12" Body	(NULL)	
	Part Number Numéro Pièce	Rev.	7
	<b>5412DDS606012B</b>	<b>0</b>	18

This drawing is confidential and must not be reproduced or used without the consent of EXM

Ce dessin est confidentiel et ne doit pas être reproduit ou utilisé sans le consentement de EXM

**STANDARD FEATURES ARE NOT LISTED IN THIS HOLE TABLE**

**HOLE TABLE - BACK VIEW (CUSTOM FEATURE ONLY)**

CUT-OUT	XDIM	YDIM	DESCRIPTION
1	2.786	2.786	IP STUD M10 x 40mm (Inside)
2	57.036	2.786	IP STUD M10 x 40mm (Inside)
3	2.786	29.911	IP STUD M10 x 40mm (Inside)
4	57.036	29.911	IP STUD M10 x 40mm (Inside)
5	2.786	57.036	IP STUD M10 x 40mm (Inside)
6	57.036	57.036	IP STUD M10 x 40mm (Inside)
7	29.911	2.786	IP STUD M10 x 40mm (Inside)
8	29.911	57.036	IP STUD M10 x 40mm (Inside)

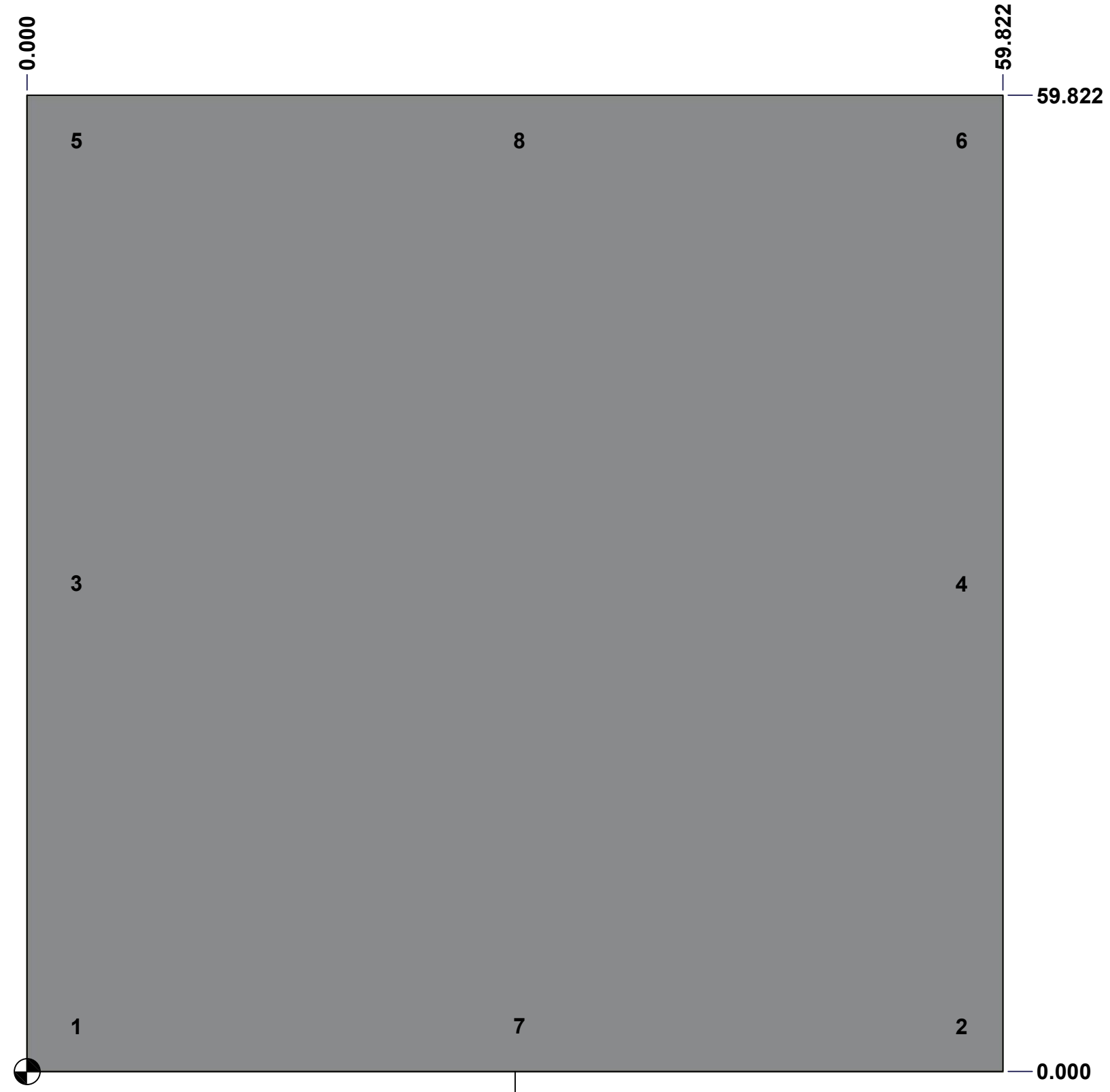

BACK

	Description	Status
	5412DDS 60" x 60" x 12" Body	(NULL)
	Part Number Numéro Pièce	Rev.
	<b>5412DDS606012B</b>	<b>0</b> / 8
		18



This drawing is confidential and must not be reproduced or used without the consent of EXM

Ce dessin est confidentiel et ne doit pas être reproduit ou utilisé sans le consentement de EXM

STANDARD FEATURES ARE NOT LISTED IN THIS HOLE TABLE			
HOLE TABLE - CENTER VIEW (CUSTOM FEATURE ONLY)			
CUT-OUT	XDIM	YDIM	DESCRIPTION
1	0.748	36.220	INTERLOCK STUD M6 x 16mm (Inside)
2	0.748	38.346	INTERLOCK STUD M6 x 16mm (Inside)
3	2.717	36.220	INTERLOCK STUD M6 x 16mm (Inside)
4	2.717	38.346	INTERLOCK STUD M6 x 16mm (Inside)

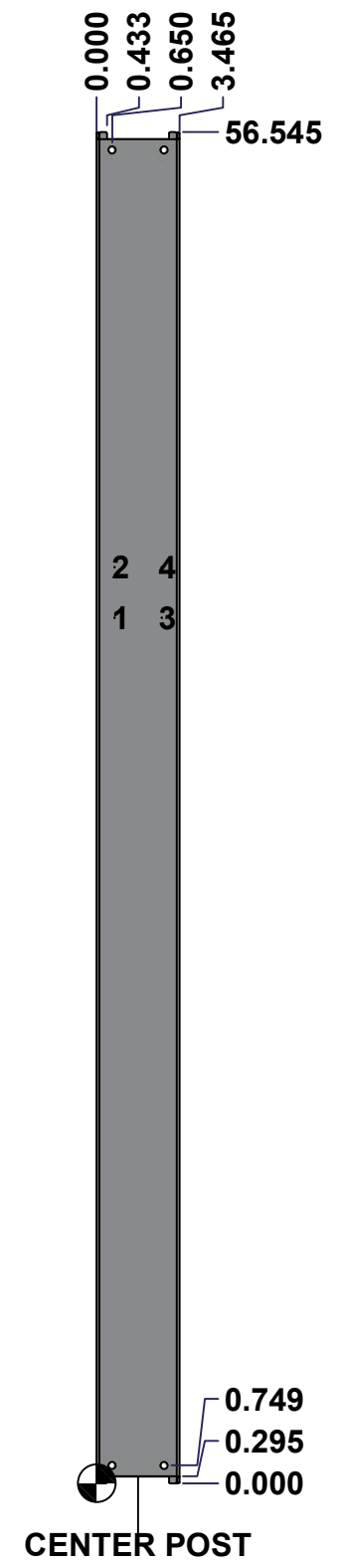

	Description	Status
	5412DDS 60" x 60" x 12" Body	(NULL)
	Part Number Numéro Pièce	Rev.
	<b>5412DDS606012B</b>	<b>0</b> / 9
		18

This drawing is confidential and must not be reproduced or used without the consent of EXM

Ce dessin est confidentiel et ne doit pas être reproduit ou utilisé sans le consentement de EXM

No.	Revisions	Date	By/Par

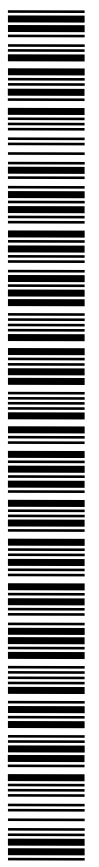
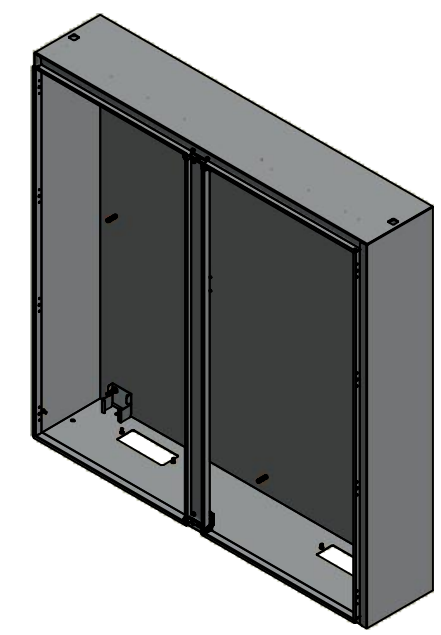

Isometric View

6	STK-Q-16030	0	Stud M6 x 10mm
6	STK-Q-07220	1	M6 Nylon Insert Lock Nut
2	STK-Q-74900	0	Eyebolt Lifting Angle (8.750")
1	STK-P-02400S	0	Powder Paint (Asa-61 Grey / Smooth)
4	STK-Q-16055	1	M6 x 18mm Stud (No Paint Cap Required)
1	STK-A-75454	3	Center Post - Sealing Block with Latch Assembly (Large)
1	5412DDS606012CP-P	0	5412DDS 60" Center Post Part
2	STK-Q-07320	0	Flange Lock Nut M10
2	STK-Q-07618	1	5500 Series Inner Panel Support Bracket
8	STK-Q-16100	0	Stud M10 x 40mm
1	5412DDS606012BT-P	0	5412DDS 60" x 12" Bottom Part
1	5412DDS606012T-P	0	5412DDS 60" x 12" Top Part
1	5412DDS606012RS-P	0	5412DDS 60" x 60" Right Part
1	5412DDS606012LS-P	0	5412DDS 60" x 60" Left Part
1	5412DDS606012B-P	0	5412DDS 60" x 60" Back Part
2	CR400MS_21.5	0	Commercial Roll Mild Steel (21.5in long)
6	STK-Q-16080	0	Ground Stud M6 x 16mm

Qty	Part Number	Rev	Description
Parts List			

Tél: (450) 979-4373 Fax: (450) 979-4626 <a href="http://www.exmweb.com">www.exmweb.com</a>	Flatness Aplatissement	Max 3.0mm
	Projection	
Customer Client	Date	
Drawn By Dessiné Par	BoxCad: BoxCad	Date 18-Sep-14
Material Matière	12 Ga Cold Rolled A1008 CS Type B (2.5mm)	
Color Couleur	Asa-61 Grey	Finish Fini Smooth
Description	5412DDS 60" x 60" x 12" Body	
Part Number Numéro Pièce	Rev. 0	10/18
<b>5412DDS606012B</b>		

This drawing is confidential and must not be reproduced or used without the consent of EXM

Ce dessin est confidentiel et ne doit pas être reproduit ou utilisé sans le consentement de EXM



TOP



BACK

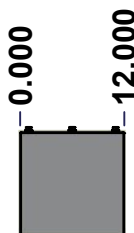

LEFT



FRONT

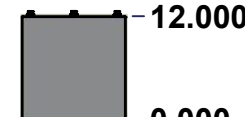

RIGHT



BOTTOM

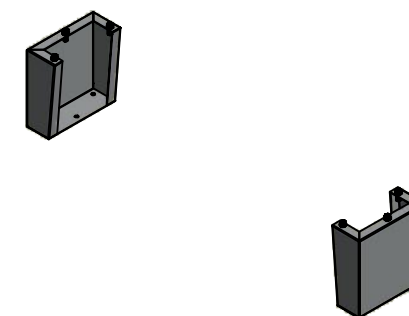

Isometric View



No.	Revisions	Date	By/Par

 Tél: (450) 979-4373  
 Fax: (450) 979-4626  
[www.exmweb.com](http://www.exmweb.com)

Flatness  
 Aplatissement  
 Max 3.0mm  
 Projection

Customer Client	Date
Drawn By Dessiné Par BoxCad: BoxCad	Date 18-Sep-14

Material Matière 12 Ga Cold Rolled A1008 CS Type B (2.5mm)

Color Couleur	Asa-61 Grey	Finish Fini	Smooth
---------------	-------------	-------------	--------

Description	Detail Rev.
885 MFHD 12" x 12" Mounting Feet	

Part Number Numéro Pièce	Rev.	11
<b>5412DDS606012MF</b>	<b>0</b>	18

SEE BILL OF MATERIAL ON LAST PAGE

This drawing is confidential and must not be reproduced or used without the consent of EXM

Ce dessin est confidentiel et ne doit pas être reproduit ou utilisé sans le consentement de EXM

No.	Revisions	Date	By/Par

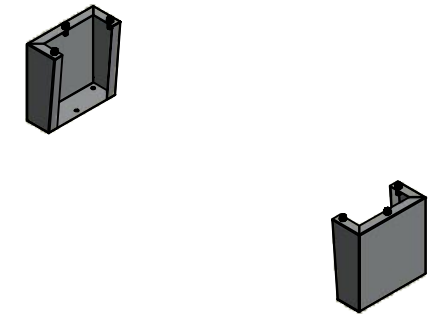

Isometric View

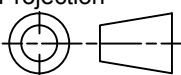

 Tél: (450) 979-4373 Fax: (450) 979-4626 <a href="http://www.exmweb.com">www.exmweb.com</a>		Flatness Aplatissement Max 3.0mm Projection 
Customer Client	Date	
Drawn By Dessiné Par	BoxCad: BoxCad	Date 18-Sep-14
Material Matière	12 Ga Cold Rolled A1008 CS Type B (2.5mm)	
Color Couleur	Asa-61 Grey	Finish Fini Smooth
Description		Detail Rev.
885 MFHD 12" x 12" Mounting Feet		
Part Number Numéro Pièce	Rev.	12
<b>5412DDS606012MF</b>	<b>0</b>	18

Qty	Part Name	Rev	Description
1	STK-P-02400S	0	Powder Paint (Asa-61 Grey / Smooth)
6	RIVET_NUT_M10_FH_CE	0	Rivet Nut M10 (Low Profile Close End)
1	5412DDS606012MFR-P	0	885 MFHD 12" x 12" Right Mounting Feet Part
1	5412DDS606012MFL-P	0	885 MFHD 12" x 12" Left Mounting Feet Part
1	STK-K-11600	2	885 MF Accessory Kit
Parts List			

This drawing is confidential and must not be reproduced or used without the consent of EXM

Ce dessin est confidentiel et ne doit pas être reproduit ou utilisé sans le consentement de EXM

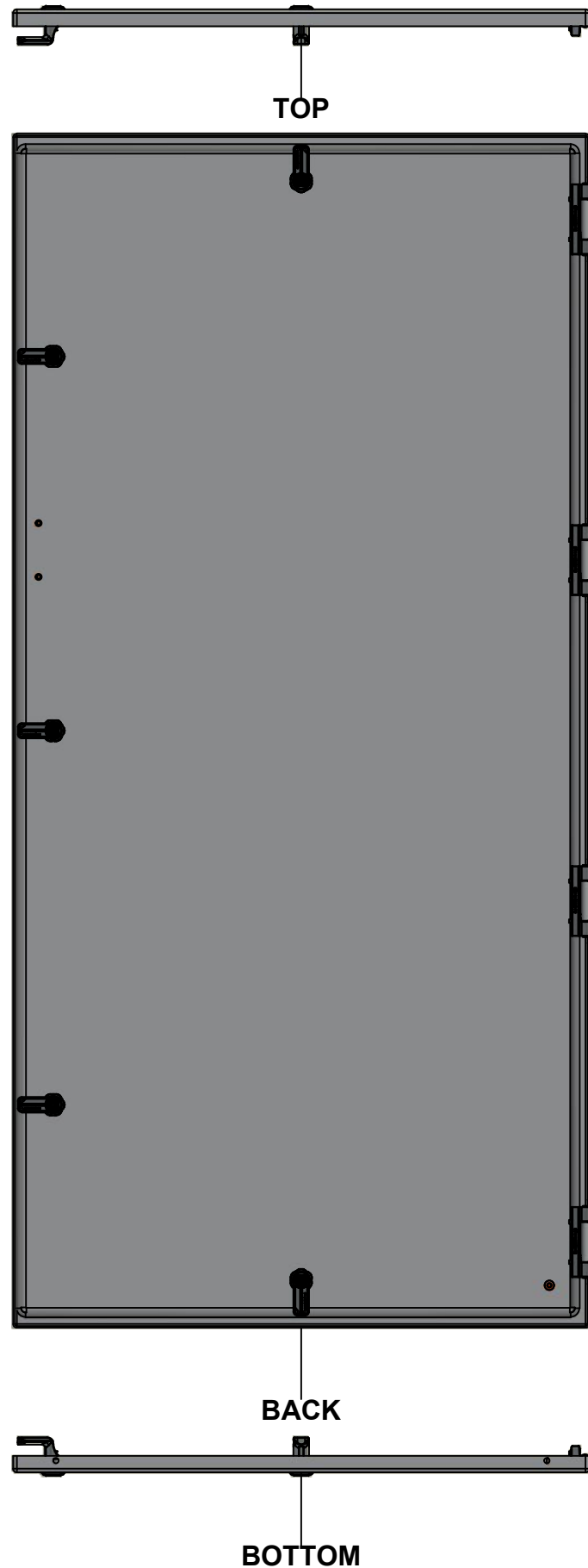

No.	Revisions	Date	By/Par

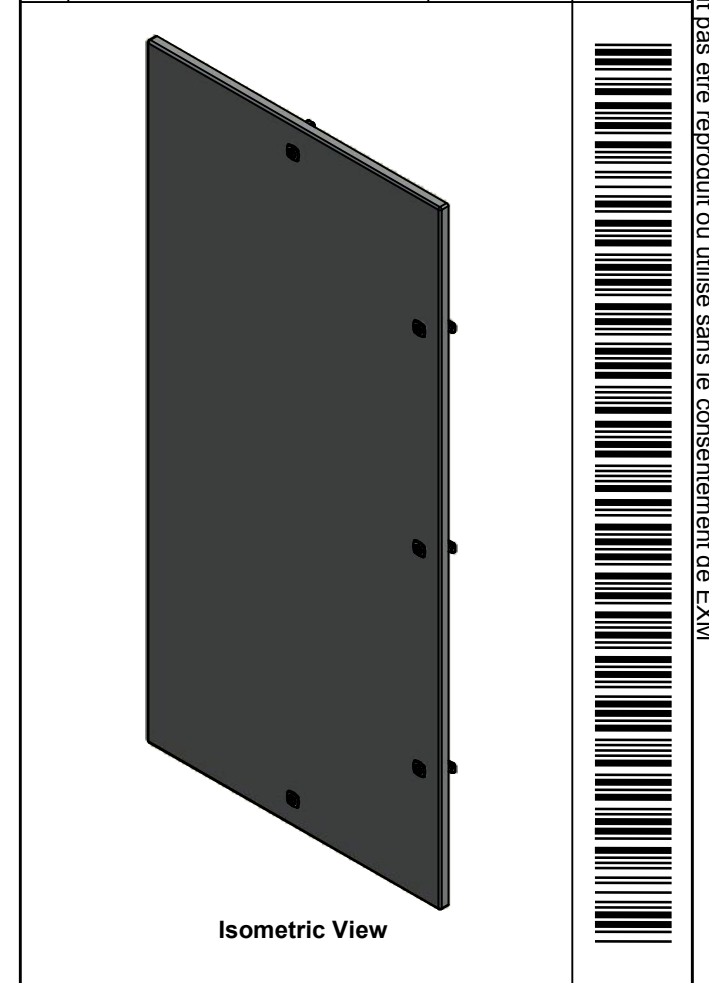

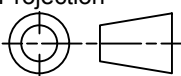
 Tél: (450) 979-4373 Fax: (450) 979-4626 <a href="http://www.exmweb.com">www.exmweb.com</a>		Flatness Aplatissement Max 3.0mm Projection 
Customer Client	Date	
Drawn By Dessiné Par	BoxCad: BoxCad	Date 18-Sep-14
Material Matière	12 Ga Cold Rolled A1008 CS Type B (2.5mm)	
Color Couleur	Asa-61 Grey	Finish Fini Smooth
Description 5412DDS 60" x 60" Slave Door		Detail Rev.
Part Number Numéro Pièce	Rev. 0	13 18

SEE BILL OF MATERIAL ON LAST PAGE

**5412DDS606012LD**

This drawing is confidential and must not be reproduced or used without the consent of EXM

Ce dessin est confidentiel et ne doit pas être reproduit ou utilisé sans le consentement de EXM

**STANDARD FEATURES ARE NOT LISTED IN THIS HOLE TABLE**

**HOLE TABLE - FRONT VIEW (CUSTOM FEATURE ONLY)**

CUT-OUT	XDIM	YDIM	DESCRIPTION
1	2.000	2.118	GND STUD M6 x 16mm (Inside)
2	26.750	11.118	LOCK 889 SCQ4-SL @ 0.0°
3	26.750	48.430	LOCK 889 SCQ4-SL @ 0.0°
4	26.750	29.774	LOCK 889 SCQ4-SL @ 0.0°
5	14.375	57.180	LOCK 889 SCQ4-SL @ 90.0°
6	14.375	2.368	LOCK 889 SCQ4-SL @ 270.0°
7	27.489	37.445	STUDS M6 x 18mm (Inside)
8	27.489	40.123	STUDS M6 x 18mm (Inside)

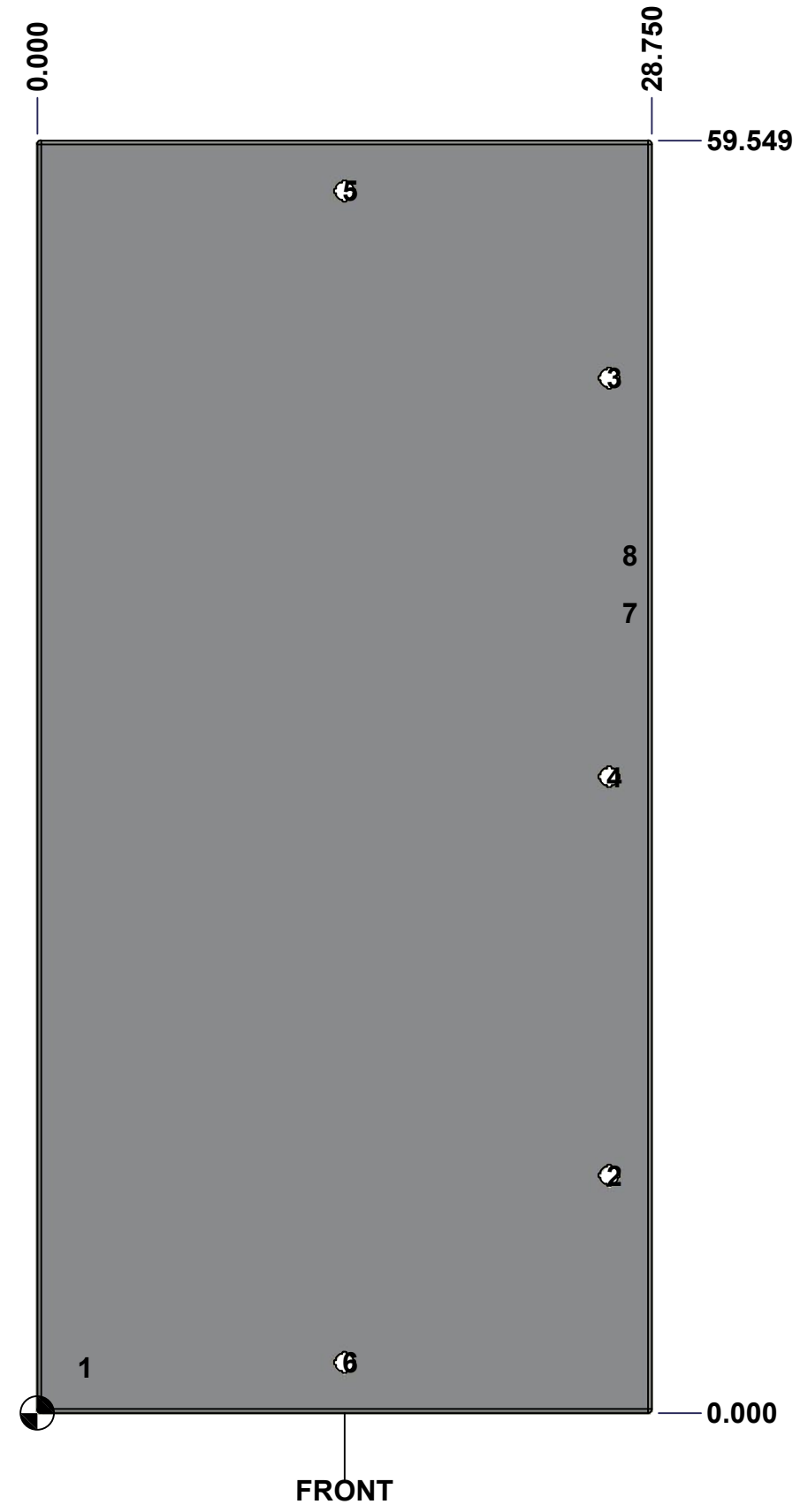

FRONT

	Description	Status	
	5412DDS 60" x 60" Slave Door	(NULL)	
	Part Number Numéro Pièce	Rev.	14
	<b>5412DDS606012LD</b>	<b>0</b>	18

This drawing is confidential and must not be reproduced or used without the consent of EXM

Ce dessin est confidentiel et ne doit pas être reproduit ou utilisé sans le consentement de EXM

No.	Revisions	Date	By/Par

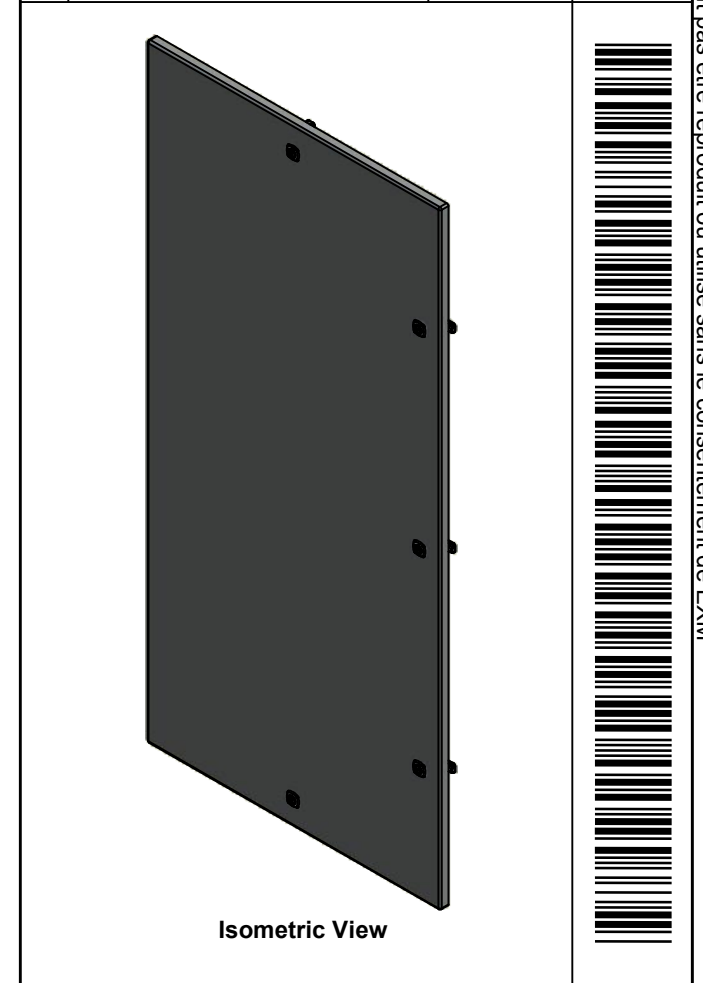

**EXM**  
www.exmweb.com

Tél: (450) 979-4373  
Fax: (450) 979-4626

Flatness  
Aplatissement  
Max 3.0mm

Projection

Customer Client \_\_\_\_\_ Date \_\_\_\_\_

Drawn By / Dessiné Par BoxCad: BoxCad Date 18-Sep-14

Material / Matière 12 Ga Cold Rolled A1008 CS Type B (2.5mm)

Color / Couleur Asa-61 Grey Finish / Fini Smooth

Description 5412DDS 60" x 60" Slave Door Detail Rev. \_\_\_\_\_

Part Number / Numéro Pièce **5412DDS606012LD** Rev. **0** 15/18

Qty	Part Name	Rev	Description
2	STK-Q-16055	1	M6 x 18mm Stud (No Paint Cap Required)
1	5412DDS606012DG	0	5412DDS 60" x 60" Door Gasket
1	STK-Q-16080	0	Ground Stud M6 x 16mm
1	STK-P-02400S	0	Powder Paint (Asa-61 Grey / Smooth)
1	5412DDS606012LD-P	0	5412DDS 60" x 60" Slave Door Part
4	STK-K-09860	7	Cabinet Hinge with Captive Pins
5	STK-K-12580	0	9412 1/4 Turn Lock
Parts List			

This drawing is confidential and must not be reproduced or used without the consent of EXM

Ce dessin est confidentiel et ne doit pas être reproduit ou utilisé sans le consentement de EXM

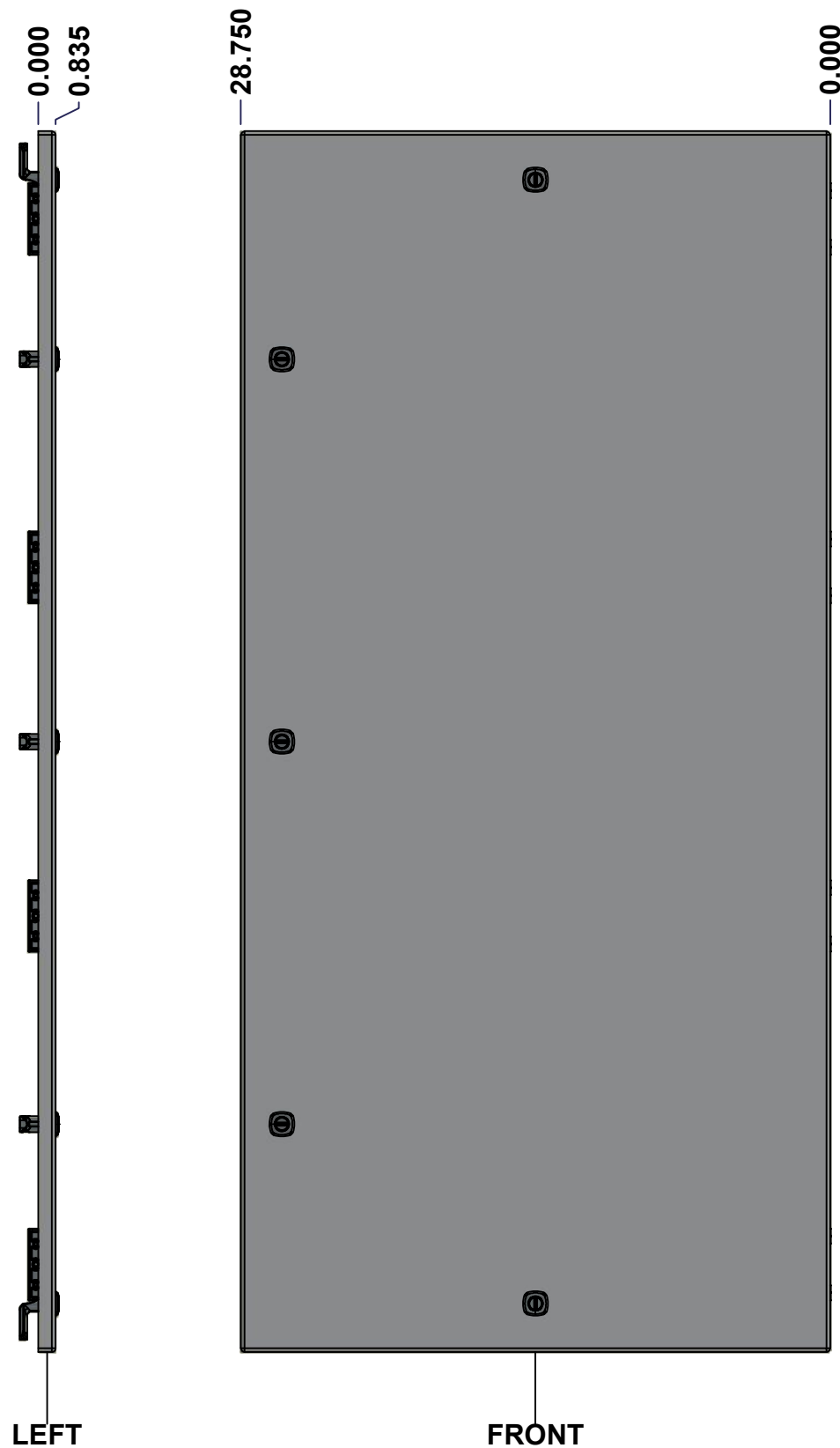
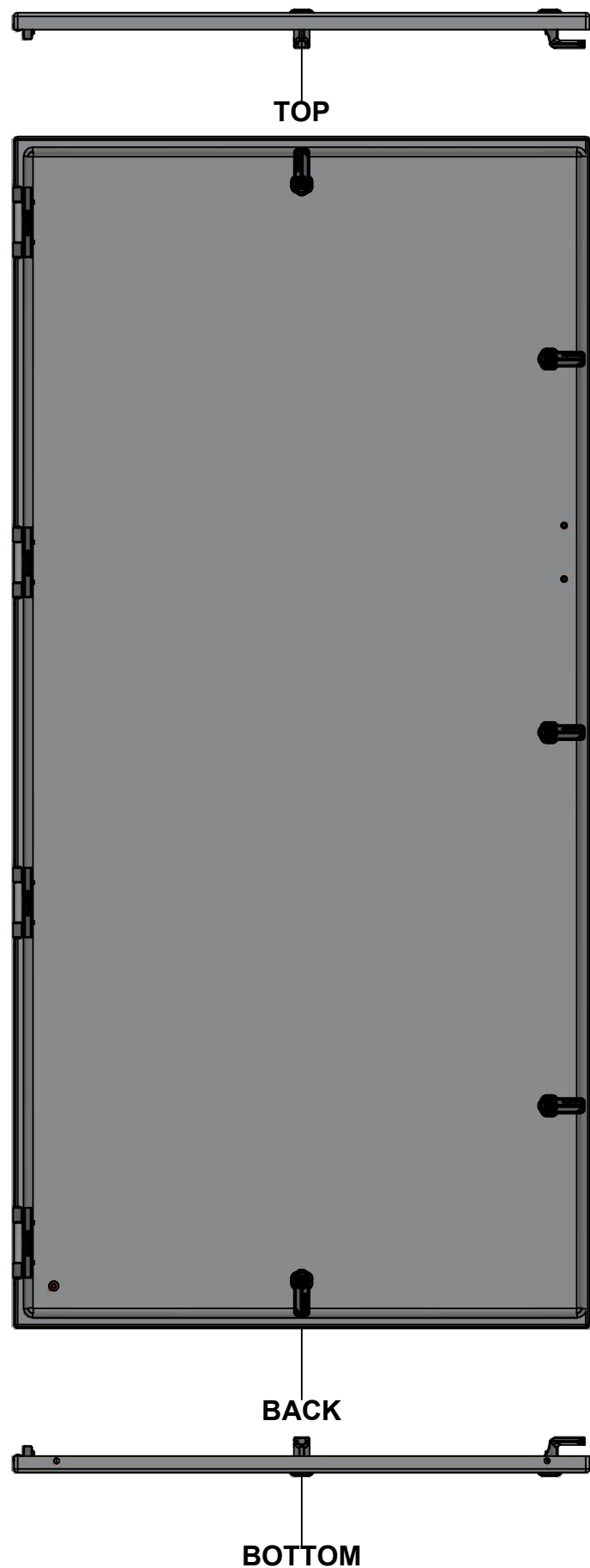

No.	Revisions	Date	By/Par

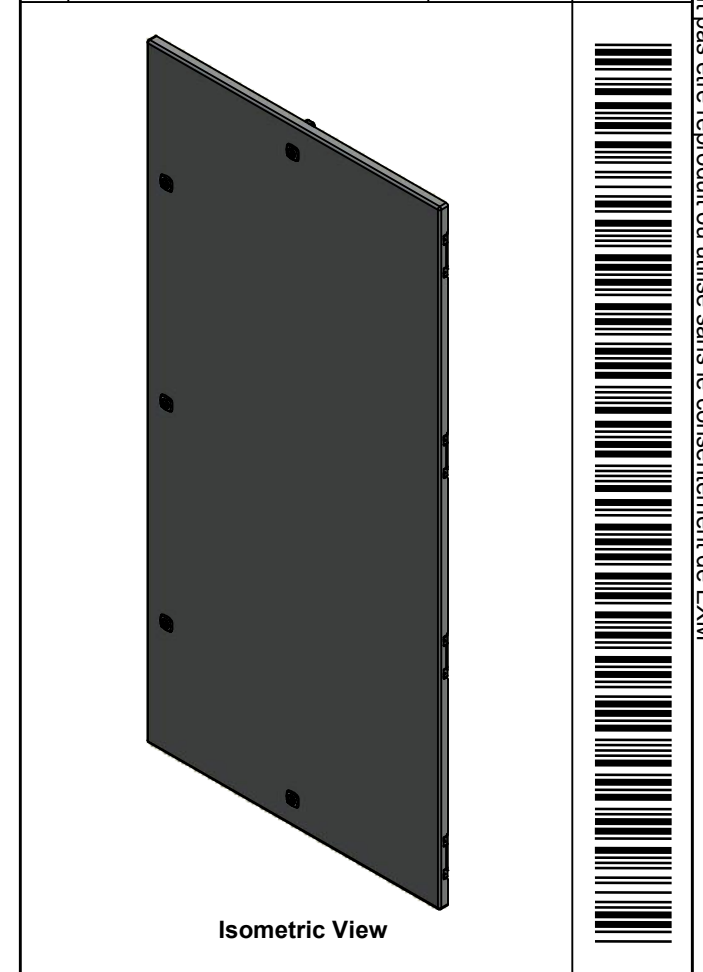

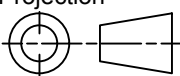
 Tél: (450) 979-4373 Fax: (450) 979-4626 <a href="http://www.exmweb.com">www.exmweb.com</a>	Flatness Aplatissement	Max 3.0mm
	Projection	
Customer Client	Date	
Drawn By Dessiné Par	BoxCad: BoxCad	Date 18-Sep-14
Material Matière	12 Ga Cold Rolled A1008 CS Type B (2.5mm)	
Color Couleur	Asa-61 Grey	Finish Fini Smooth
Description	Detail Rev.	
5412DDS 60" x 60" Master Door		
Part Number Numéro Pièce	Rev. 0	16 / 18

SEE BILL OF MATERIAL ON LAST PAGE

**5412DDS606012FD**



This drawing is confidential and must not be reproduced or used without the consent of EXM

Ce dessin est confidentiel et ne doit pas être reproduit ou utilisé sans le consentement de EXM

**STANDARD FEATURES ARE NOT LISTED IN THIS HOLE TABLE**

**HOLE TABLE - FRONT VIEW (CUSTOM FEATURE ONLY)**

CUT-OUT	XDIM	YDIM	DESCRIPTION
1	2.000	2.118	GND STUD M6 x 16mm (Inside)
2	26.750	48.430	LOCK 889 SCQ4-SL @ 180.0°
3	26.750	29.774	LOCK 889 SCQ4-SL @ 180.0°
4	26.750	11.118	LOCK 889 SCQ4-SL @ 180.0°
5	14.375	57.180	LOCK 889 SCQ4-SL @ 90.0°
6	14.375	2.368	LOCK 889 SCQ4-SL @ 270.0°
7	27.489	37.445	STUDS M6 x 18mm (Inside)
8	27.489	40.123	STUDS M6 x 18mm (Inside)

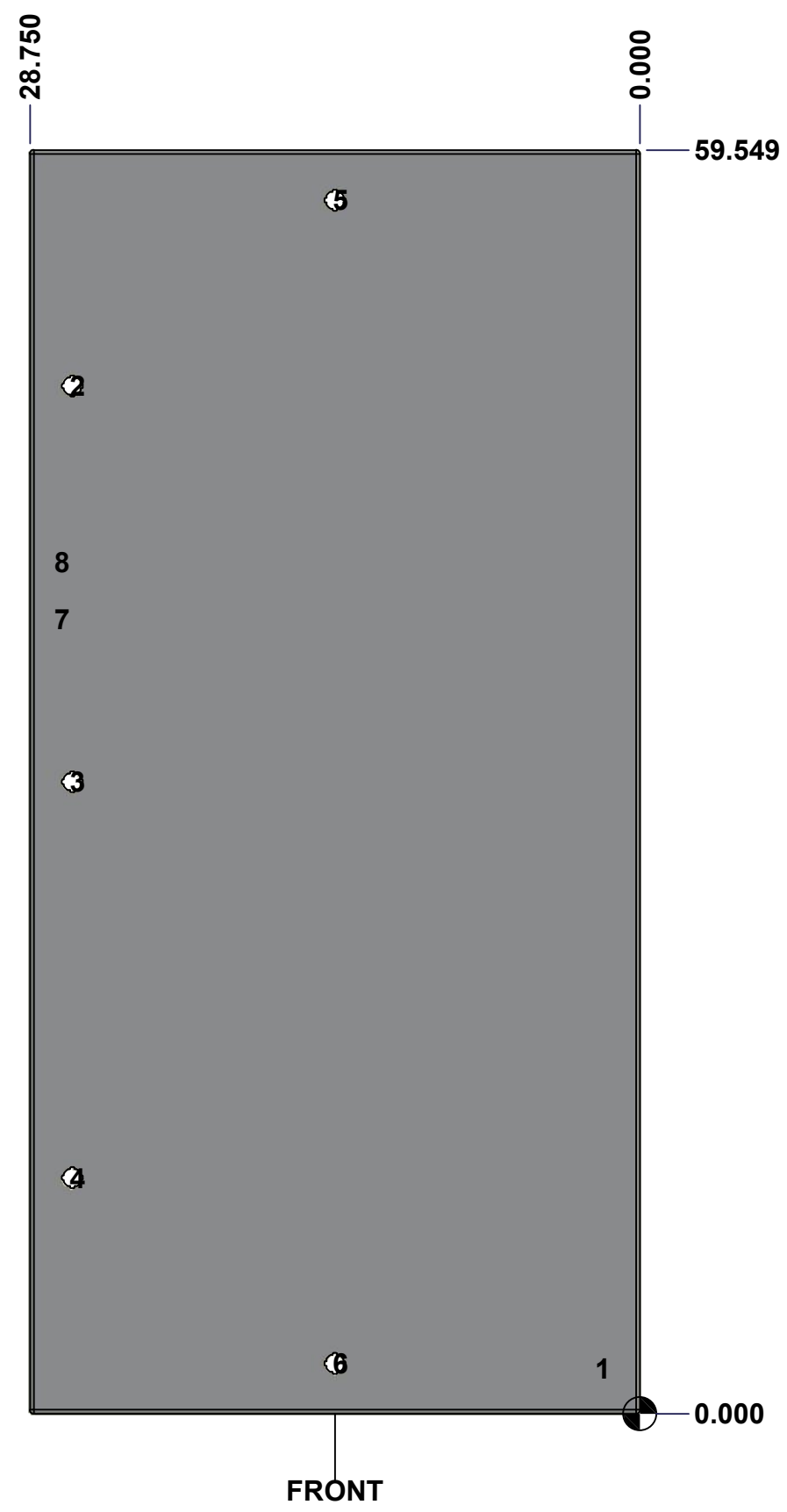

	Description	Status
	5412DDS 60" x 60" Master Door	(NULL)
	Part Number Numéro Pièce	Rev.
	<b>5412DDS606012FD</b>	<b>0</b>
		17 18

This drawing is confidential and must not be reproduced or used without the consent of EXM

Ce dessin est confidentiel et ne doit pas être reproduit ou utilisé sans le consentement de EXM

No.	Revisions	Date	By/Par

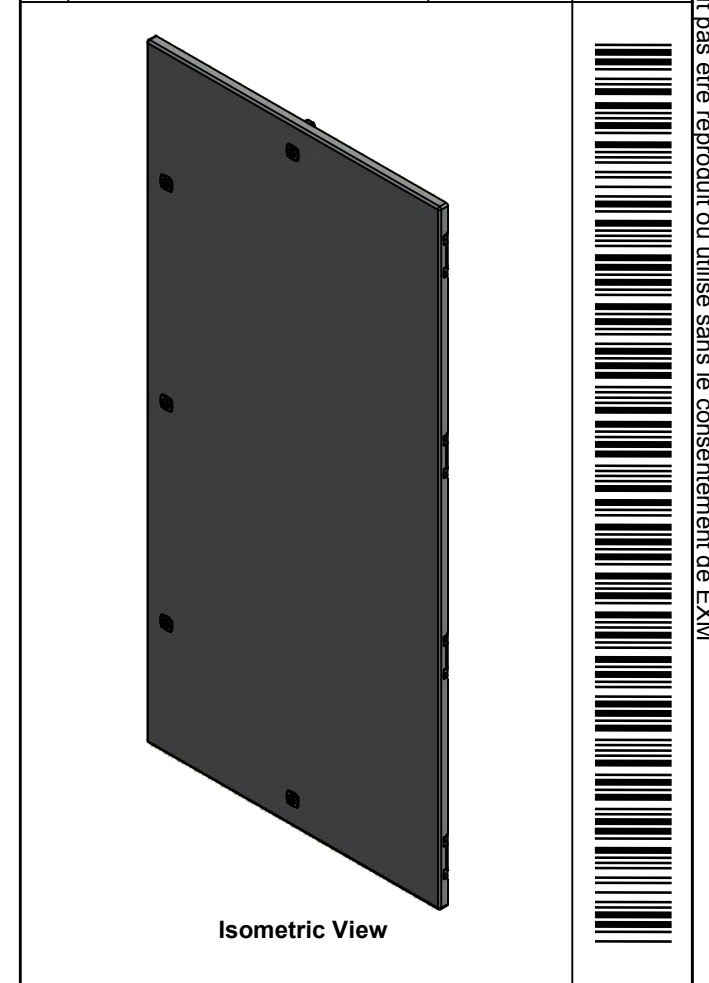

**EXM**  
www.exmweb.com

Tél: (450) 979-4373  
Fax: (450) 979-4626

Flatness  
Aplatissement  
Max 3.0mm

Projection

Customer Client \_\_\_\_\_ Date \_\_\_\_\_

Drawn By / Dessiné Par BoxCad: BoxCad Date 18-Sep-14

Material / Matière 12 Ga Cold Rolled A1008 CS Type B (2.5mm)

Color / Couleur Asa-61 Grey Finish / Fini Smooth

Description 5412DDS 60" x 60" Master Door Detail Rev. \_\_\_\_\_

Part Number / Numéro Pièce **5412DDS606012FD** Rev. **0** 18/18

2	STK-Q-16055	1	M6 x 18mm Stud (No Paint Cap Required)
1	5412DDS606012DG	0	5412DDS 60" x 60" Door Gasket
1	STK-Q-16080	0	Ground Stud M6 x 16mm
1	STK-P-02400S	0	Powder Paint (Asa-61 Grey / Smooth)
1	5412DDS606012FD-P	0	5412DDS 60" x 60" Master Door Part
4	STK-K-09860	7	Cabinet Hinge with Captive Pins
5	STK-K-12580	0	9412 1/4 Turn Lock
Qty	Part Name	Rev	Description
Parts List			

This drawing is confidential and must not be reproduced or used without the consent of EXM

Ce dessin est confidentiel et ne doit pas être reproduit ou utilisé sans le consentement de EXM

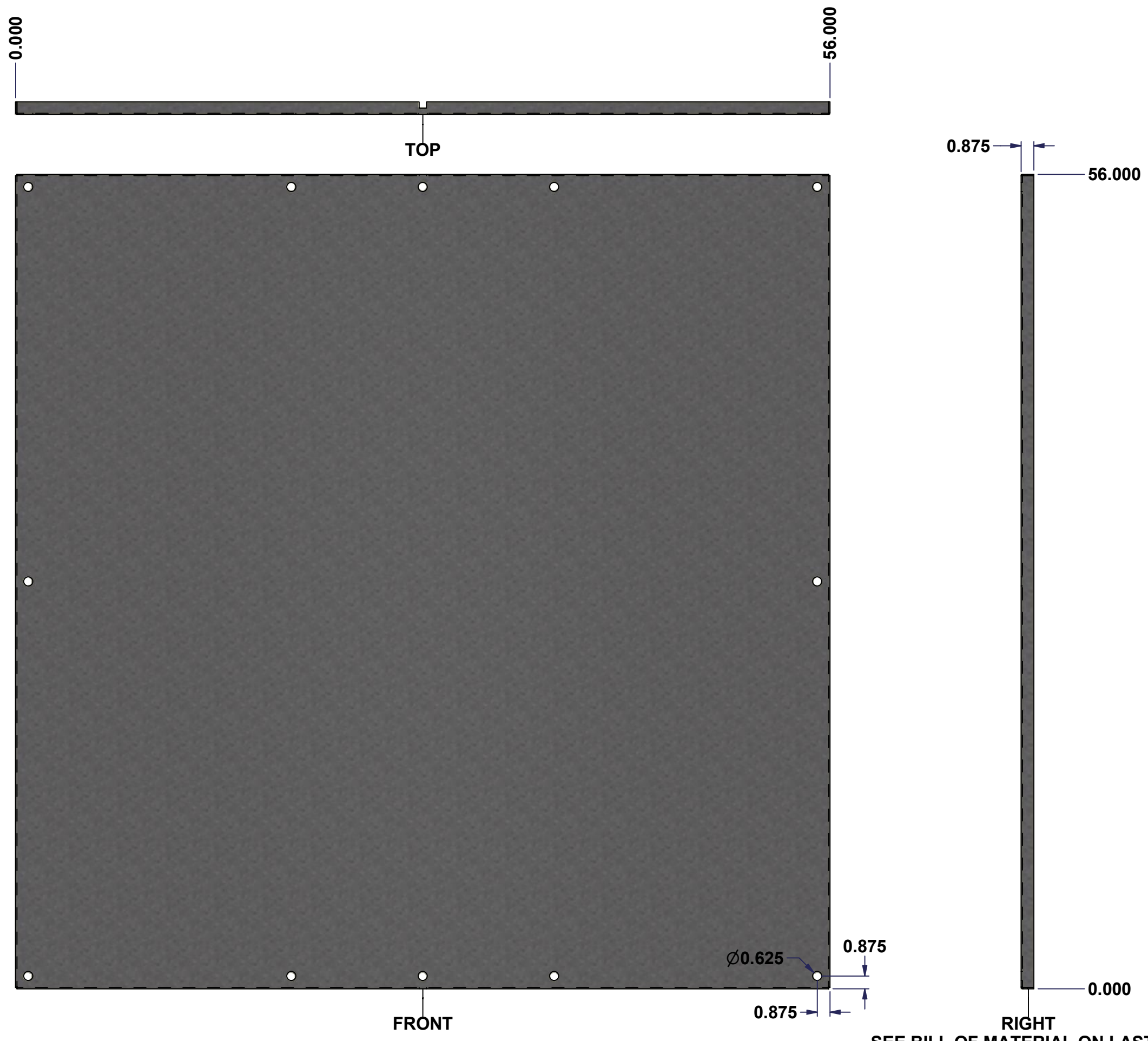

No.	Revisions	Date	By/Par

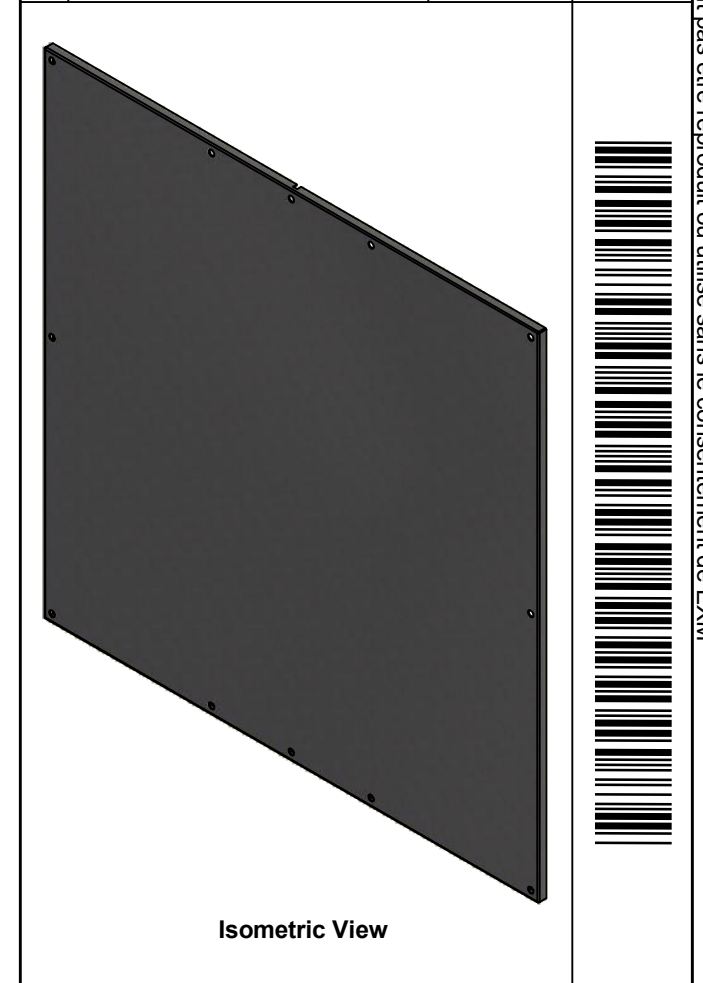

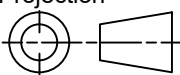
 Tél: (450) 979-4373 Fax: (450) 979-4626 www.exmweb.com	Flatness Aplatissement Max 3.0mm
	Projection 
Customer Client	Date
Drawn By Dessiné Par BoxCad	Date 04/11/2009
Material Matière 12 Ga Galvanized (2.5mm)	
Color Couleur Unpainted	Finish Fini Unpainted
Description 885 SP6060G Inner Panel	
Part Number Numéro Pièce <b>885SP6060G</b>	Detail Rev.
Rev. <b>0</b>	1 2

**SEE BILL OF MATERIAL ON LAST PAGE**

This drawing is confidential and must not be reproduced or used without the consent of EXM

Ce dessin est confidentiel et ne doit pas être reproduit ou utilisé sans le consentement de EXM

No.	Revisions	Date	By/Par

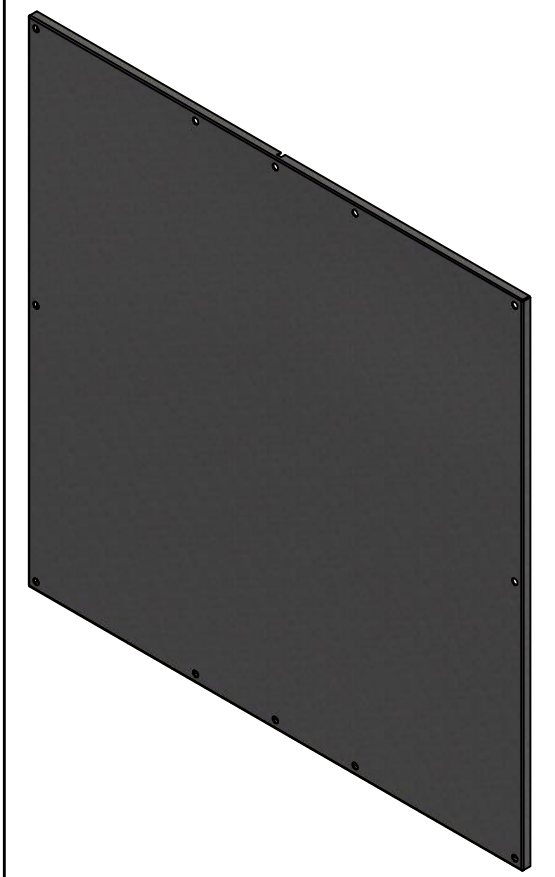

Isometric View

 Tél: (450) 979-4373 Fax: (450) 979-4626 www.exmweb.com		Flatness Aplatissement Max 3.0mm
Customer Client		Date
Drawn By / Dessiné Par: BoxCad		Date: 04/11/2009
Material / Matière: 12 Ga Galvanized (2.5mm)		
Color / Couleur: Unpainted	Finish / Fini: Unpainted	
Description: 885 SP6060G Inner Panel		Detail Rev.
Part Number / Numéro Pièce: <b>885SP6060G</b>		Rev. 0 / 2

Qty	Part Number	Rev	Description
1	885SP6060G-P	0	885 SP6060G Inner Panel Part
Parts List			