

This drawing is confidential and must not be reproduced or used without the consent of EXM

Ce dessin est confidentiel et ne doit pas être reproduit ou utilisé sans le consentement de EXM

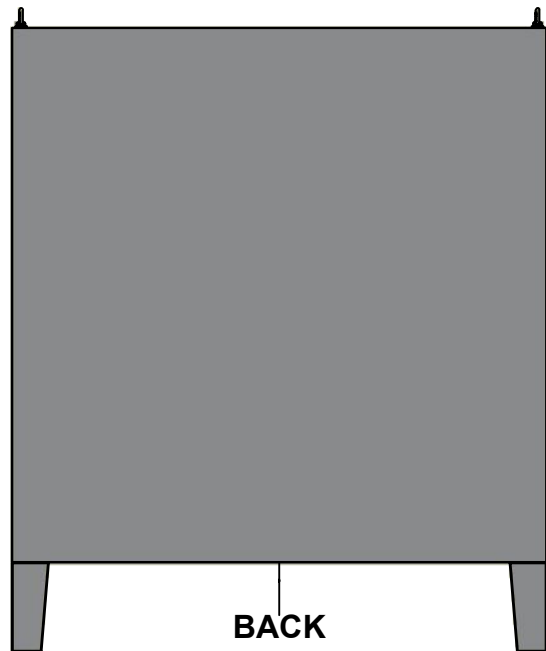

TOP



BACK

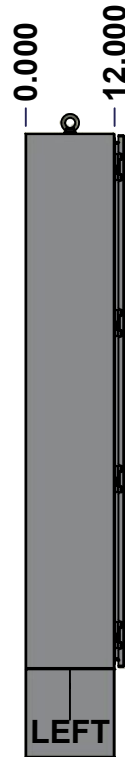

LEFT

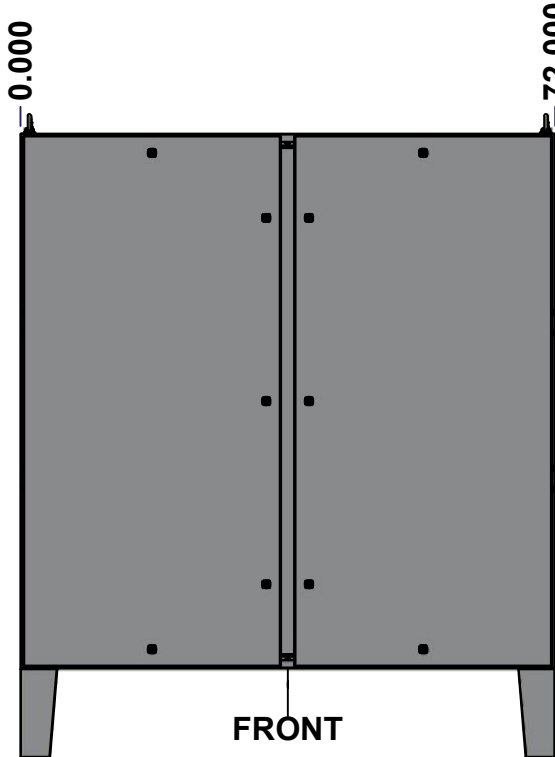

FRONT

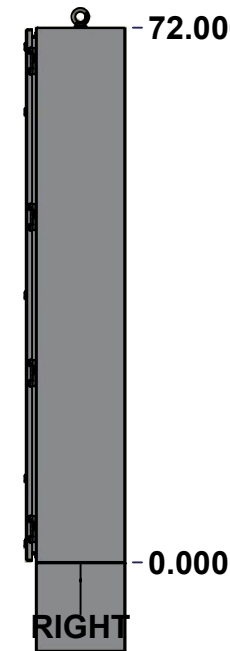

RIGHT



BOTTOM

No.	Revisions	Date	By/Par

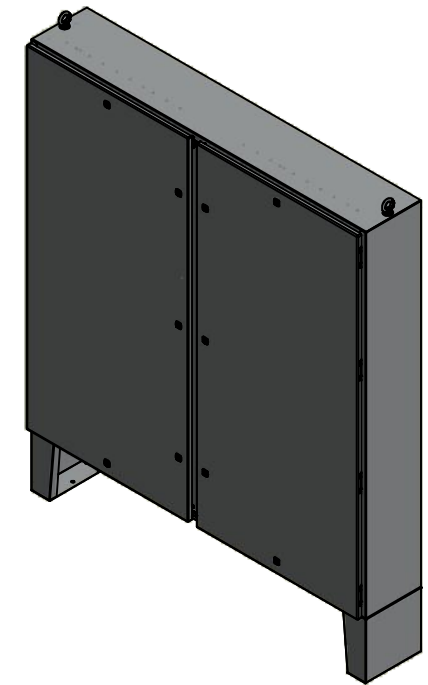

Isometric View



Tél: (450) 979-4373
 Fax: (450) 979-4626
www.exmweb.com

Flatness
Aplatissement

Max 3.0mm

Projection

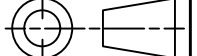

Customer Client	Date
Drawn By Dessiné Par	Date

BoxCad: BoxCad
 2014-09-18
 Material
Matière

12 Ga Cold Rolled A1008 CS Type B (2.5mm)
 Color
Couleur

Asa-61 Grey
 Finish
Fini

Smooth
 Description

5412DDS 72" x 72" x 12" Assembly
 Detail Rev.

Part Number Numéro Pièce	Rev.	1
5412DDS727212	0	18

SEE BILL OF MATERIAL ON LAST PAGE

This drawing is confidential and must not be reproduced or used without the consent of EXM

Ce dessin est confidentiel et ne doit pas être reproduit ou utilisé sans le consentement de EXM

NOTE	
ITEM	DESCRIPTION
1	NEMA 4/12 Enclosure
2	C/W Standard ground studs on box and cover
3	W/O Standard door stiffener
4	C/W Standard inner panel (Included)
5	C/W Standard inner panel mounting studs
6	C/W Struts installed (Included)
7	C/W 880 PPL included (Not installed)
8	C/W Eyebolts
9	C/W Mounting feet sold separately (Installed)
10	C/W Interlock Kit (Installed by EXM)

No.	Revisions	Date	By/Par

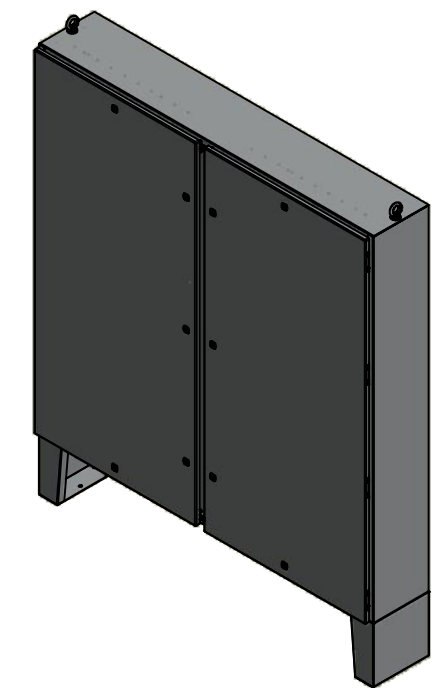

Isometric View

PACKING		
ITEM	QTY	DESCRIPTION
Cardboard sleeve	2	Top and Bottom
Cardboard strip	2	Between back of enclosure and inner panel
Plastic bag	1	To protect cover surface and inside gasket
Cardboard corner	4	To reinforced for the plastic strap tightening
Plastic strap - Black	2	To Squeeze 2 cardboard sleeve together
Packaging label	3	White label with PN
Plastic strap- Green	2	To secure the enclosure to the wood pallet
Wood Pallet	1	2" deeper and 3" larger than enclosure size

1	5412DDS727212MF	0	885 MFHD 12" x 12" Mounting Feet
1	880INTI	2	880 INTI - Interlock Post Kit
1	880EB14	2	Eye Bolt M14 (Pack of 2)
8	STK-Q-07320	0	Flange Lock Nut M10
1	885SP7272G	0	885 SP7272G Inner Panel
8	STK-Q-07620	0	M10 Plastic Spacer 0.875"
1	5412DDS727212FD	0	5412DDS 72" x 72" Master Door
1	5412DDS727212LD	0	5412DDS 72" x 72" Slave Door
1	5412DDS727212B	0	5412DDS 72" x 72" x 12" Body
2	5412DDS727212GP	0	5412DDS Gland Plate
8	STK-Q-04050-10	8	M6 x 10mm Hexagon Socket Head Machine Screw with Nyseal
Qty	Part Number	Rev	Description
Parts List			

	Tél: (450) 979-4373 Fax: (450) 979-4626 www.exmweb.com	Flatness Aplatissement Max 3.0mm Projection
	Customer Client	Date
Drawn By Dessiné Par	BoxCad: BoxCad	Date 2014-09-18
Material Matière	12 Ga Cold Rolled A1008 CS Type B (2.5mm)	
Color Couleur	Asa-61 Grey	Finish Fini Smooth
Description 5412DDS 72" x 72" x 12" Assembly		Detail Rev.
Part Number Numéro Pièce 5412DDS727212		Rev. 0 2 18

This drawing is confidential and must not be reproduced or used without the consent of EXM

Ce dessin est confidentiel et ne doit pas être reproduit ou utilisé sans le consentement de EXM



TOP



BACK

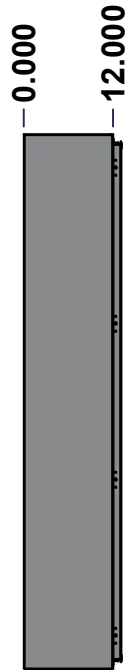

LEFT

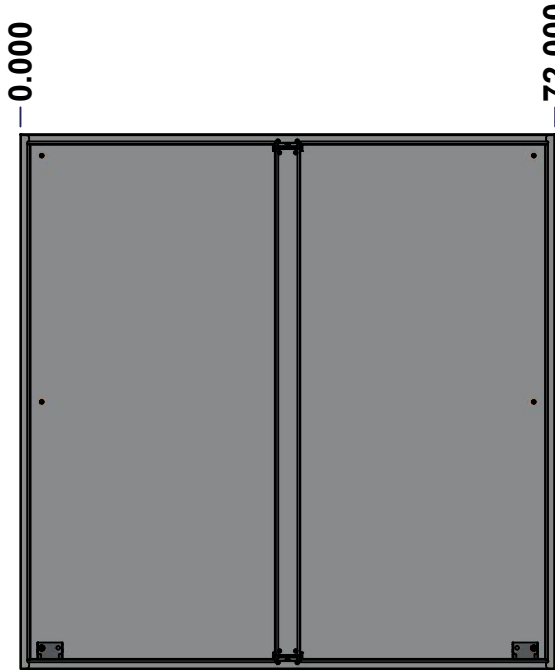

FRONT

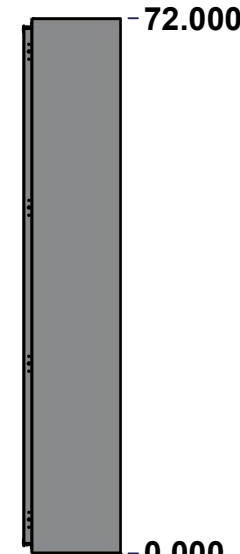

RIGHT



BOTTOM

No.	Revisions	Date	By/Par

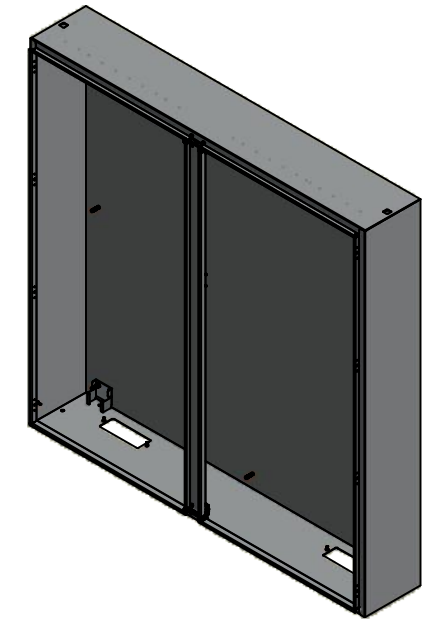

Isometric View



Tél: (450) 979-4373
 Fax: (450) 979-4626
www.exmweb.com

Flatness
Aplatissement

Max 3.0mm

Projection



Customer Client	Date
Drawn By / Dessiné Par: BoxCad: BoxCad	Date: 2014-09-18
Material / Matière: 12 Ga Cold Rolled A1008 CS Type B (2.5mm)	

Color / Couleur: Asa-61 Grey	Finish / Fini: Smooth
------------------------------	-----------------------

Description: 5412DDS 72" x 72" x 12" Body	Detail Rev.
---	-------------

Part Number / Numéro Pièce: 5412DDS727212B	Rev. 0	3
--	--------	---

SEE BILL OF MATERIAL ON LAST PAGE

This drawing is confidential and must not be reproduced or used without the consent of EXM

Ce dessin est confidentiel et ne doit pas être reproduit ou utilisé sans le consentement de EXM

STANDARD FEATURES ARE NOT LISTED IN THIS HOLE TABLE

HOLE TABLE - TOP VIEW (CUSTOM FEATURE ONLY)

CUT-OUT	XDIM	YDIM	DESCRIPTION
1	53.911	7.911	Struts CR400 27.500" (Inside)
2	17.911	7.911	Struts CR400 27.500" (Inside)
3	53.911	7.911	STUDS M6 x 10mm (Inside)
4	43.161	7.911	STUDS M6 x 10mm (Inside)
5	64.661	7.911	STUDS M6 x 10mm (Inside)
6	17.911	7.911	STUDS M6 x 10mm (Inside)
7	7.161	7.911	STUDS M6 x 10mm (Inside)
8	28.661	7.911	STUDS M6 x 10mm (Inside)

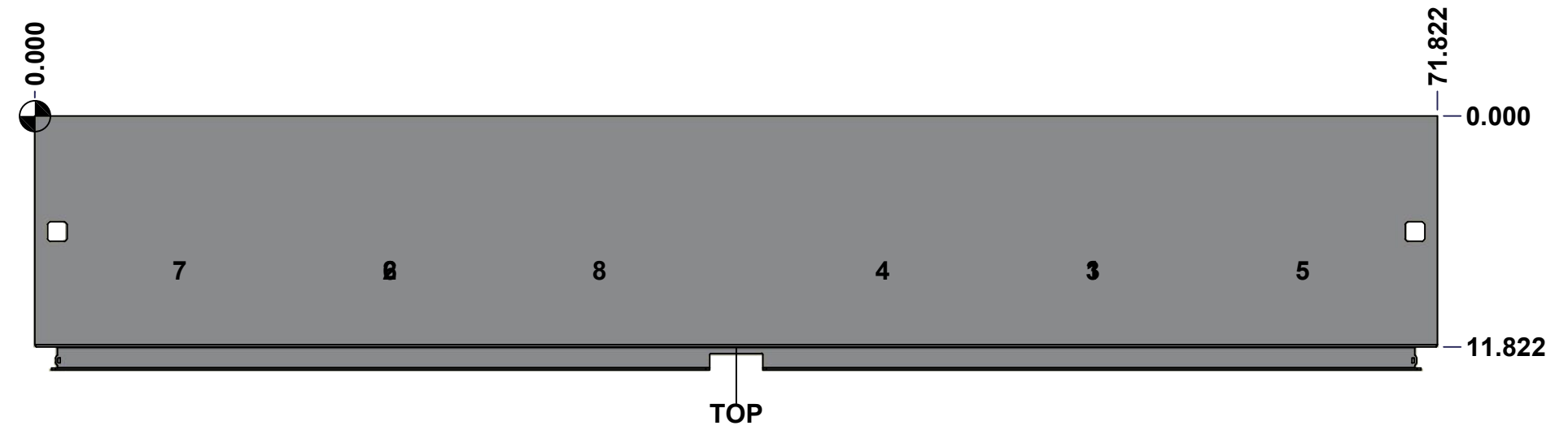

	Description	Status
	5412DDS 72" x 72" x 12" Body	(NULL)
	Part Number Numéro Pièce	Rev.
	5412DDS727212B	0
		4
		18

This drawing is confidential and must not be reproduced or used without the consent of EXM

Ce dessin est confidentiel et ne doit pas être reproduit ou utilisé sans le consentement de EXM

STANDARD FEATURES ARE NOT LISTED IN THIS HOLE TABLE			
HOLE TABLE - RIGHT VIEW (CUSTOM FEATURE ONLY)			
CUT-OUT	XDIM	YDIM	DESCRIPTION
1	10.411	3.286	GND STUD M6 x 16mm (Inside)

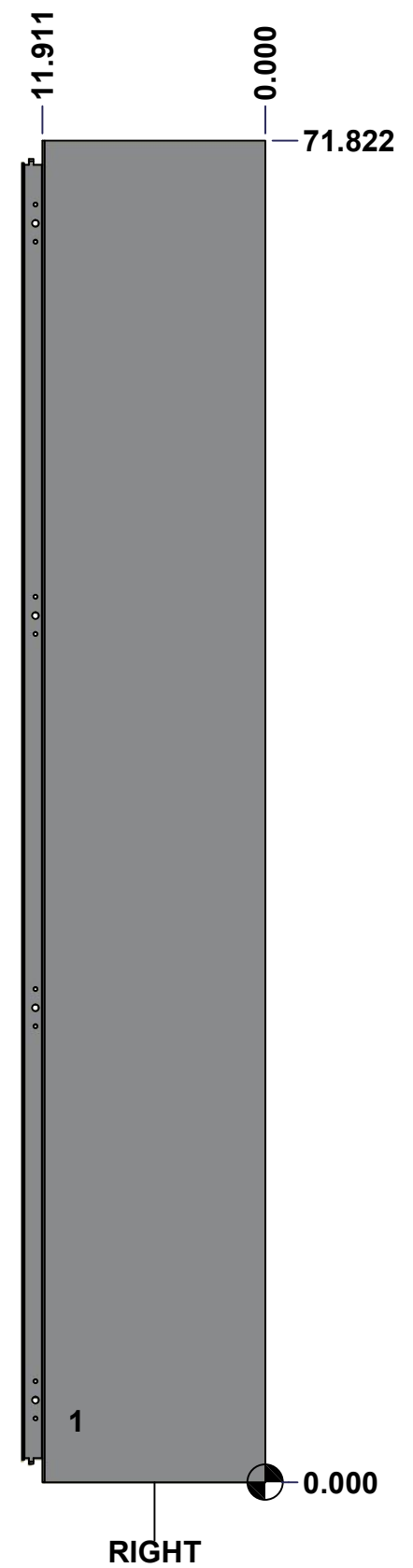

	Description	Status
	5412DDS 72" x 72" x 12" Body	(NULL)
	Part Number Numéro Pièce	Rev.
	5412DDS727212B	0 / 5
		18

This drawing is confidential and must not be reproduced or used without the consent of EXM

Ce dessin est confidentiel et ne doit pas être reproduit ou utilisé sans le consentement de EXM

STANDARD FEATURES ARE NOT LISTED IN THIS HOLE TABLE

HOLE TABLE - BOTTOM VIEW (CUSTOM FEATURE ONLY)

CUT-OUT	XDIM	YDIM	DESCRIPTION
1	7.286	3.411	GP STUD M6 x 16mm (Inside)
2	16.536	3.411	GP STUD M6 x 16mm (Inside)
3	55.286	3.411	GP STUD M6 x 16mm (Inside)
4	64.536	3.411	GP STUD M6 x 16mm (Inside)

5	3.911	0.911	RND Ø0.500
6	0.911	5.911	RND Ø0.500
7	3.911	10.911	RND Ø0.500
8	67.911	0.911	RND Ø0.500
9	70.911	5.911	RND Ø0.500
10	67.911	10.911	RND Ø0.500

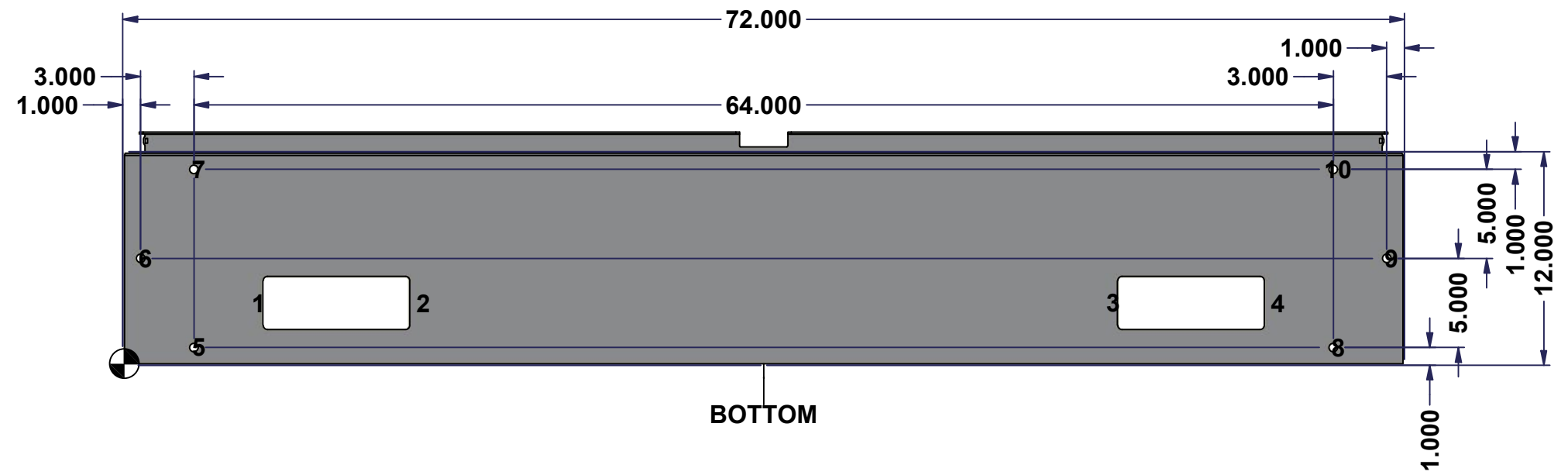

	Description	Status
	5412DDS 72" x 72" x 12" Body	(NULL)
	Part Number Numéro Pièce	Rev.
	5412DDS727212B	0 / 6
		18

This drawing is confidential and must not be reproduced or used without the consent of EXM

Ce dessin est confidentiel et ne doit pas être reproduit ou utilisé sans le consentement de EXM

STANDARD FEATURES ARE NOT LISTED IN THIS HOLE TABLE			
HOLE TABLE - LEFT VIEW (CUSTOM FEATURE ONLY)			
CUT-OUT	XDIM	YDIM	DESCRIPTION
1	10.411	3.286	GND STUD M6 x 16mm (Inside)

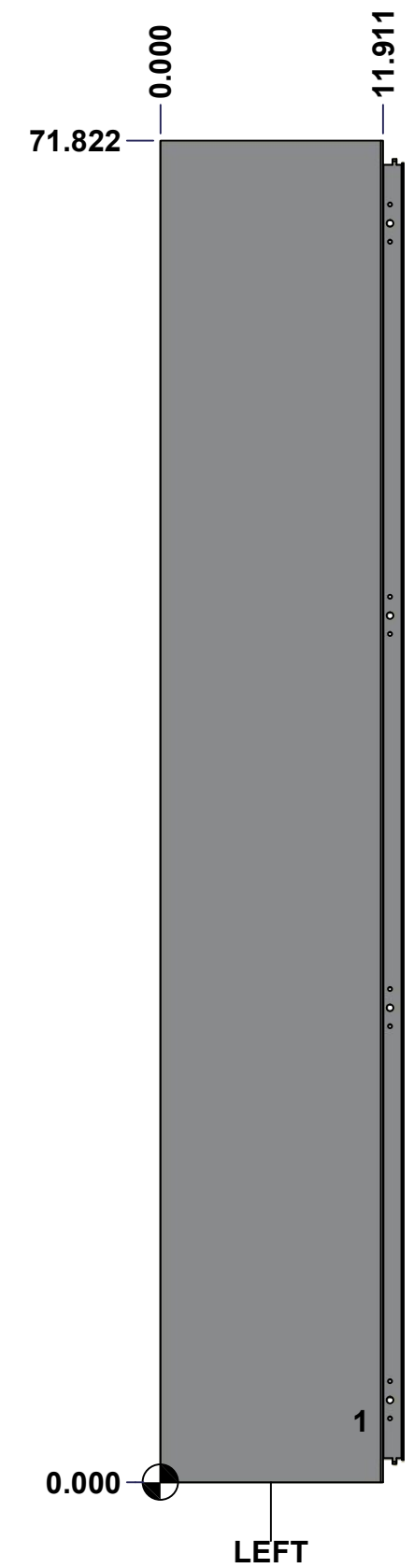

	Description	Status	
	5412DDS 72" x 72" x 12" Body	(NULL)	
	Part Number Numéro Pièce	Rev.	7
	5412DDS727212B	0	18

This drawing is confidential and must not be reproduced or used without the consent of EXM

Ce dessin est confidentiel et ne doit pas être reproduit ou utilisé sans le consentement de EXM

STANDARD FEATURES ARE NOT LISTED IN THIS HOLE TABLE

HOLE TABLE - BACK VIEW (CUSTOM FEATURE ONLY)

CUT-OUT	XDIM	YDIM	DESCRIPTION
1	2.786	2.786	IP STUD M10 x 40mm (Inside)
2	69.036	2.786	IP STUD M10 x 40mm (Inside)
3	2.786	35.911	IP STUD M10 x 40mm (Inside)
4	69.036	35.911	IP STUD M10 x 40mm (Inside)
5	2.786	69.036	IP STUD M10 x 40mm (Inside)
6	69.036	69.036	IP STUD M10 x 40mm (Inside)
7	35.911	2.786	IP STUD M10 x 40mm (Inside)
8	35.911	69.036	IP STUD M10 x 40mm (Inside)

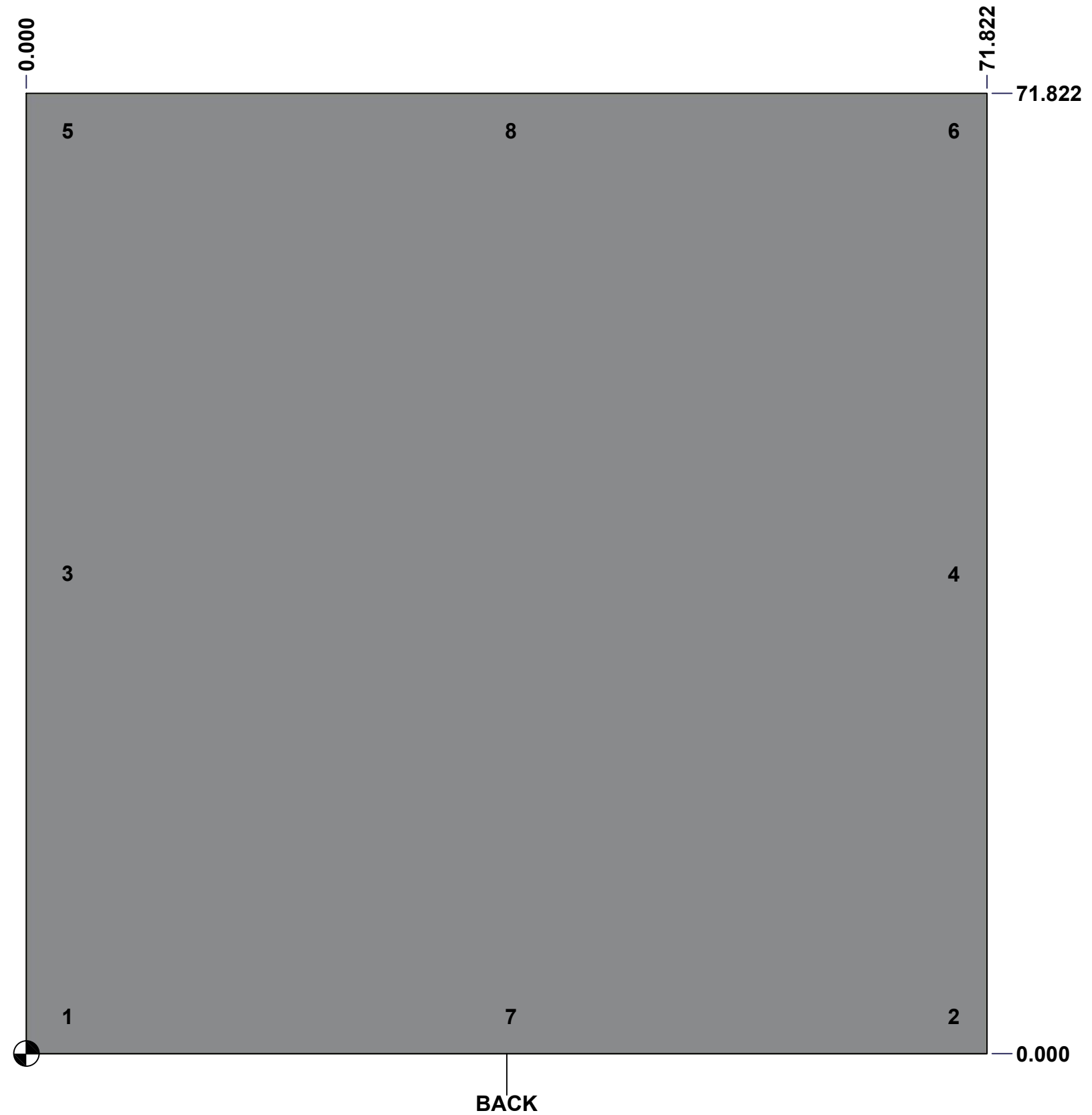

	Description	Status
	5412DDS 72" x 72" x 12" Body	(NULL)
	Part Number Numéro Pièce	Rev.
	5412DDS727212B	0 / 8
		18

This drawing is confidential and must not be reproduced or used without the consent of EXM

Ce dessin est confidentiel et ne doit pas être reproduit ou utilisé sans le consentement de EXM

STANDARD FEATURES ARE NOT LISTED IN THIS HOLE TABLE			
HOLE TABLE - CENTER VIEW (CUSTOM FEATURE ONLY)			
CUT-OUT	XDIM	YDIM	DESCRIPTION
1	0.748	42.220	INTERLOCK STUD M6 x 16mm (Inside)
2	0.748	44.346	INTERLOCK STUD M6 x 16mm (Inside)
3	2.717	42.220	INTERLOCK STUD M6 x 16mm (Inside)
4	2.717	44.346	INTERLOCK STUD M6 x 16mm (Inside)

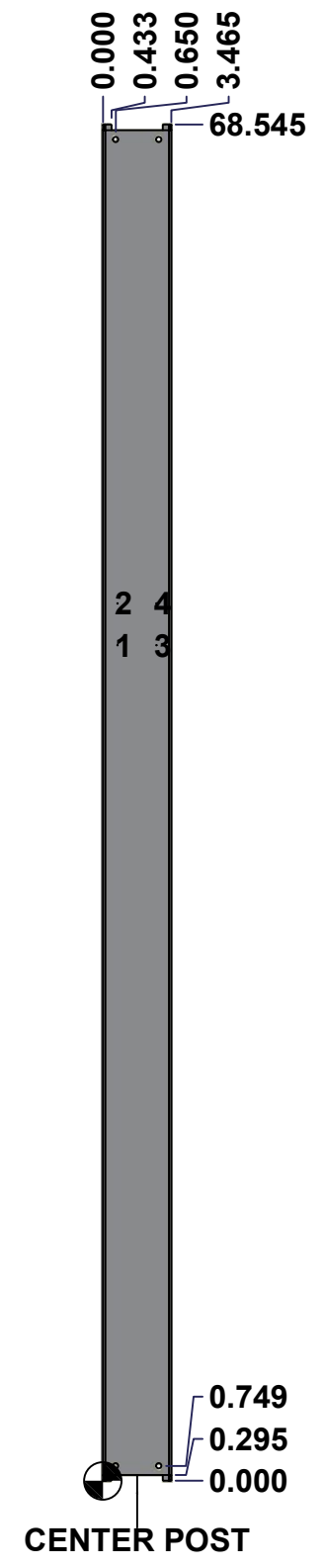

	Description	Status	
	5412DDS 72" x 72" x 12" Body	(NULL)	
	Part Number Numéro Pièce	Rev.	9
	5412DDS727212B	0	18

This drawing is confidential and must not be reproduced or used without the consent of EXM

Ce dessin est confidentiel et ne doit pas être reproduit ou utilisé sans le consentement de EXM

No.	Revisions	Date	By/Par

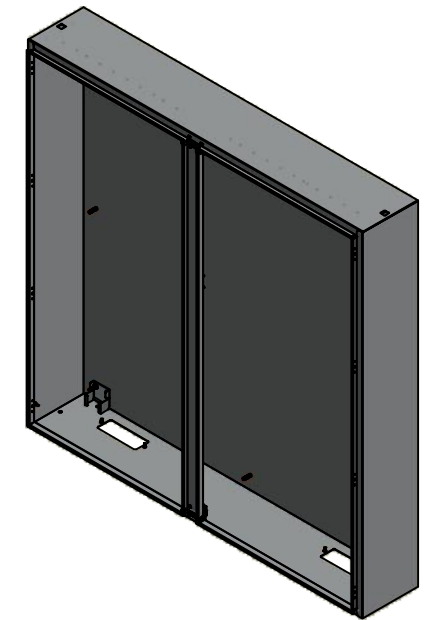

Isometric View

6	STK-Q-16030	0	Stud M6 x 10mm
6	STK-Q-07220	1	M6 Nylon Insert Lock Nut
2	STK-Q-74900	0	Eyebolt Lifting Angle (8.750")
1	STK-P-02400S	0	Powder Paint (Asa-61 Grey / Smooth)
4	STK-Q-16055	1	M6 x 18mm Stud (No Paint Cap Required)
1	STK-A-75454	3	Center Post - Sealing Block with Latch Assembly (Large)
1	5412DDS727212CP-P	0	5412DDS 72" Center Post Part
2	STK-Q-07320	0	Flange Lock Nut M10
2	STK-Q-07618	1	5500 Series Inner Panel Support Bracket
8	STK-Q-16100	0	Stud M10 x 40mm
1	5412DDS727212BT-P	0	5412DDS 72" x 12" Bottom Part
1	5412DDS727212T-P	0	5412DDS 72" x 12" Top Part
1	5412DDS727212RS-P	0	5412DDS 72" x 72" Right Part
1	5412DDS727212LS-P	0	5412DDS 72" x 72" Left Part
1	5412DDS727212B-P	0	5412DDS 72" x 72" Back Part
2	CR400MS_27.5	0	Commercial Roll Mild Steel (27.5in long)
6	STK-Q-16080	0	Ground Stud M6 x 16mm

Qty	Part Number	Rev	Description
Parts List			

Tél: (450) 979-4373 Fax: (450) 979-4626 www.exmweb.com	Flatness Aplatissement	Max 3.0mm
	Projection	
Customer Client	Date	
Drawn By Dessiné Par	BoxCad: BoxCad	Date 2014-09-18
Material Matière	12 Ga Cold Rolled A1008 CS Type B (2.5mm)	
Color Couleur	Asa-61 Grey	Finish Fini Smooth
Description	5412DDS 72" x 72" x 12" Body	
Part Number Numéro Pièce	Rev.	10 18
5412DDS727212B		0

This drawing is confidential and must not be reproduced or used without the consent of EXM

Ce dessin est confidentiel et ne doit pas être reproduit ou utilisé sans le consentement de EXM

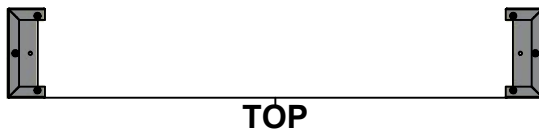

TOP

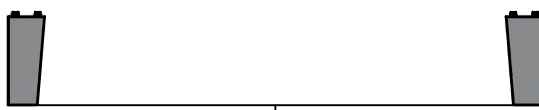

BACK

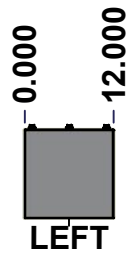

LEFT

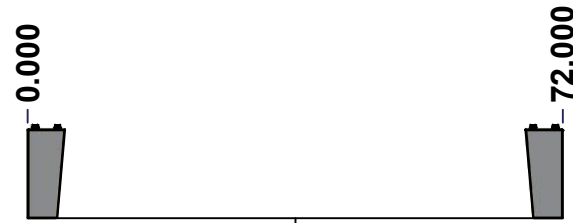

FRONT

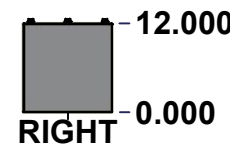

RIGHT



BOTTOM

No.	Revisions	Date	By/Par

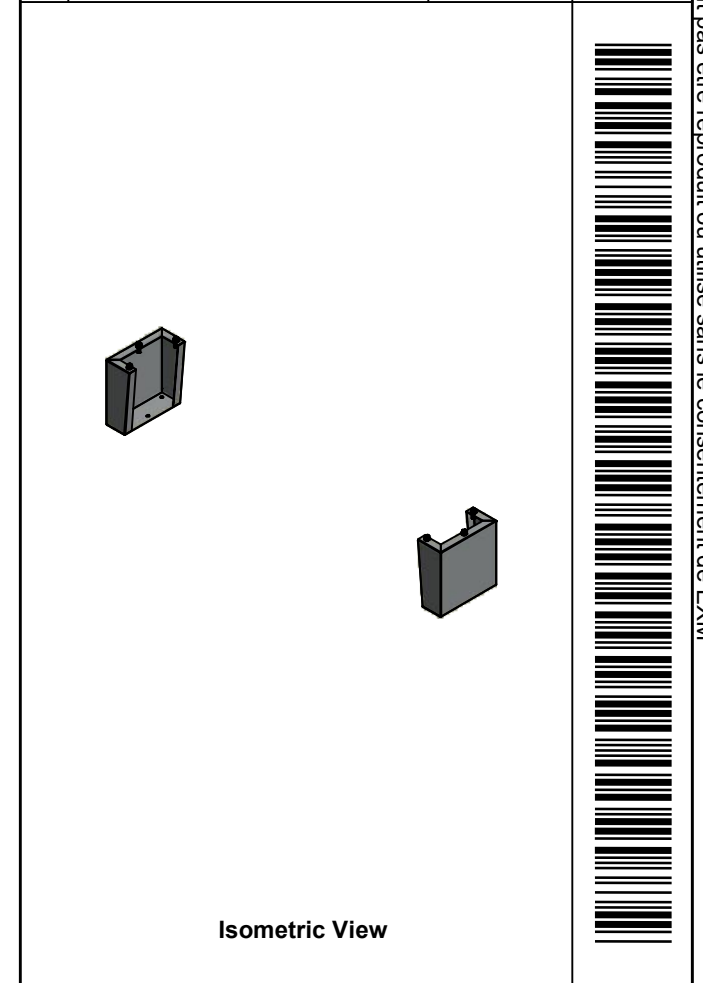

Isometric View

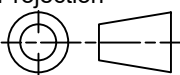

 Tél: (450) 979-4373 Fax: (450) 979-4626 www.exmweb.com		Flatness Aplatissement Max 3.0mm Projection 
Customer Client	Date	
Drawn By Dessiné Par	BoxCad: BoxCad	Date 2014-09-18
Material Matière	12 Ga Cold Rolled A1008 CS Type B (2.5mm)	
Color Couleur	Asa-61 Grey	Finish Fini Smooth
Description 885 MFHD 12" x 12" Mounting Feet		Detail Rev.
Part Number Numéro Pièce	Rev. 0	11 / 18

SEE BILL OF MATERIAL ON LAST PAGE

5412DDS727212MF

This drawing is confidential and must not be reproduced or used without the consent of EXM

Ce dessin est confidentiel et ne doit pas être reproduit ou utilisé sans le consentement de EXM

No.	Revisions	Date	By/Par

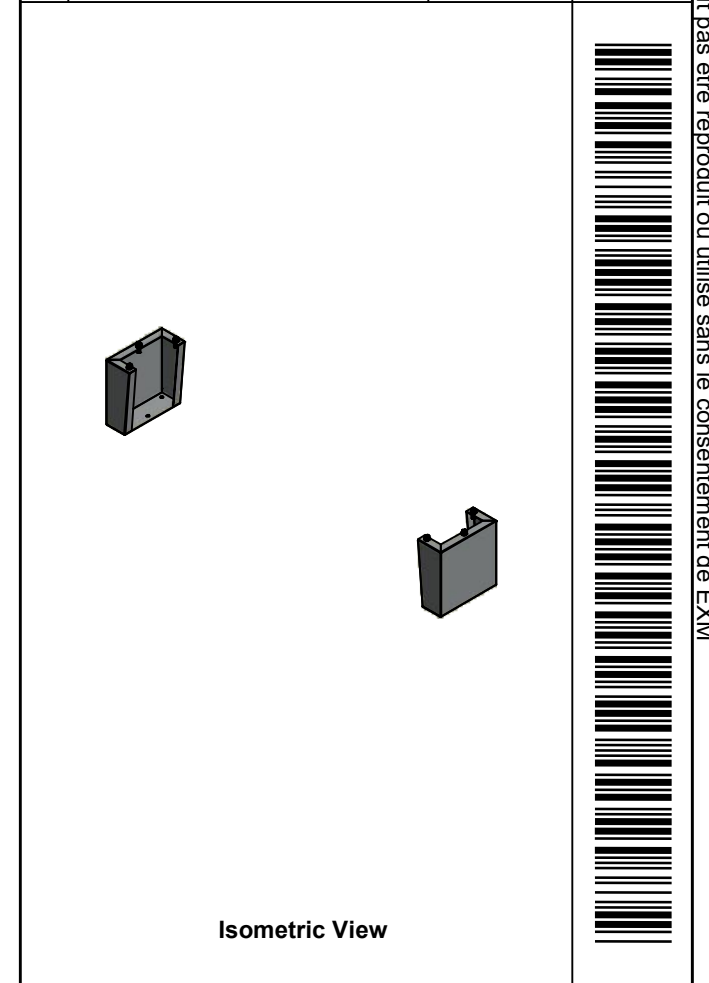

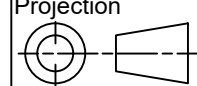
 Tél: (450) 979-4373 Fax: (450) 979-4626 www.exmweb.com		Flatness Aplatissement Max 3.0mm Projection 
Customer Client	Date	
Drawn By Dessiné Par	BoxCad: BoxCad	Date 2014-09-18
Material Matière	12 Ga Cold Rolled A1008 CS Type B (2.5mm)	
Color Couleur	Asa-61 Grey	Finish Fini Smooth
Description		Detail Rev.
885 MFHD 12" x 12" Mounting Feet		
Part Number Numéro Pièce	Rev.	12
5412DDS727212MF	0	18

Qty	Part Name	Rev	Description
1	STK-P-02400S	0	Powder Paint (Asa-61 Grey / Smooth)
6	RIVET_NUT_M10_FH_CE	0	Rivet Nut M10 (Low Profile Close End)
1	5412DDS727212MFR-P	0	885 MFHD 12" x 12" Right Mounting Feet Part
1	5412DDS727212MFL-P	0	885 MFHD 12" x 12" Left Mounting Feet Part
1	STK-K-11600	2	885 MF Accessory Kit
Parts List			

This drawing is confidential and must not be reproduced or used without the consent of EXM

Ce dessin est confidentiel et ne doit pas être reproduit ou utilisé sans le consentement de EXM

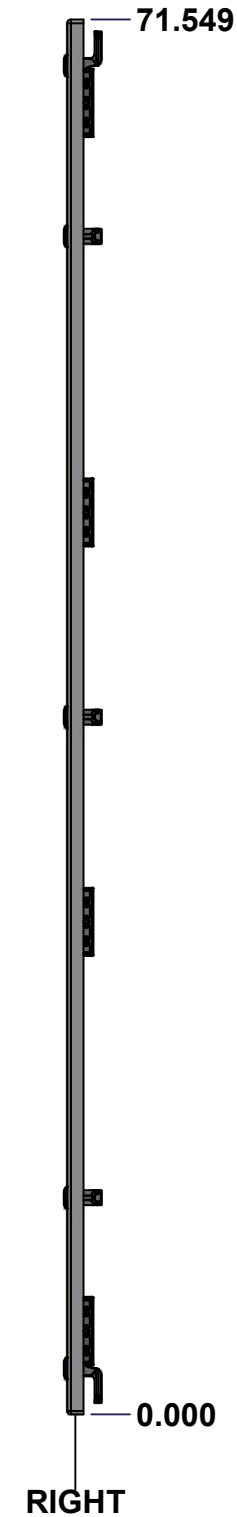
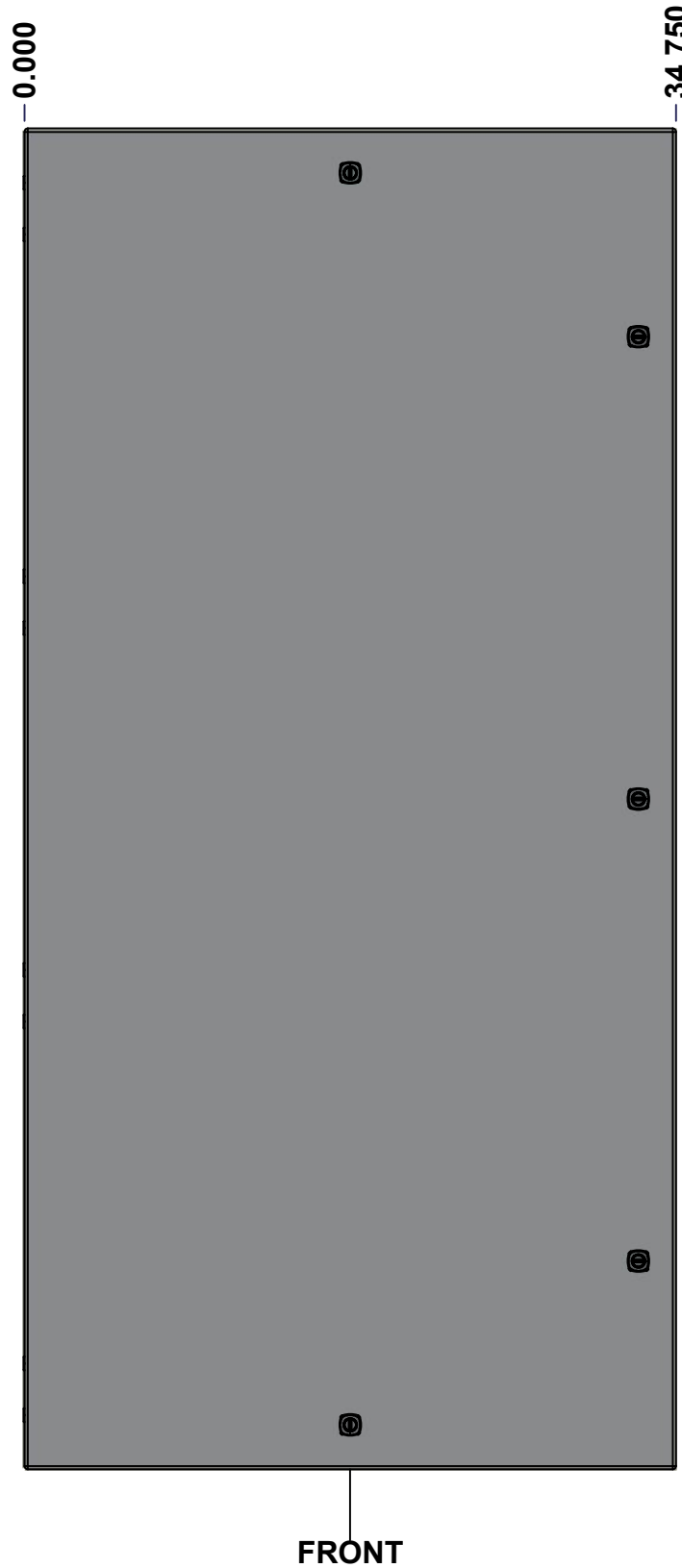
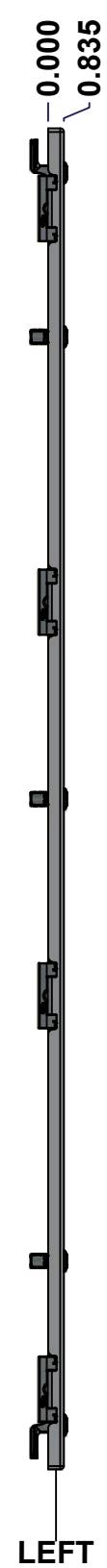
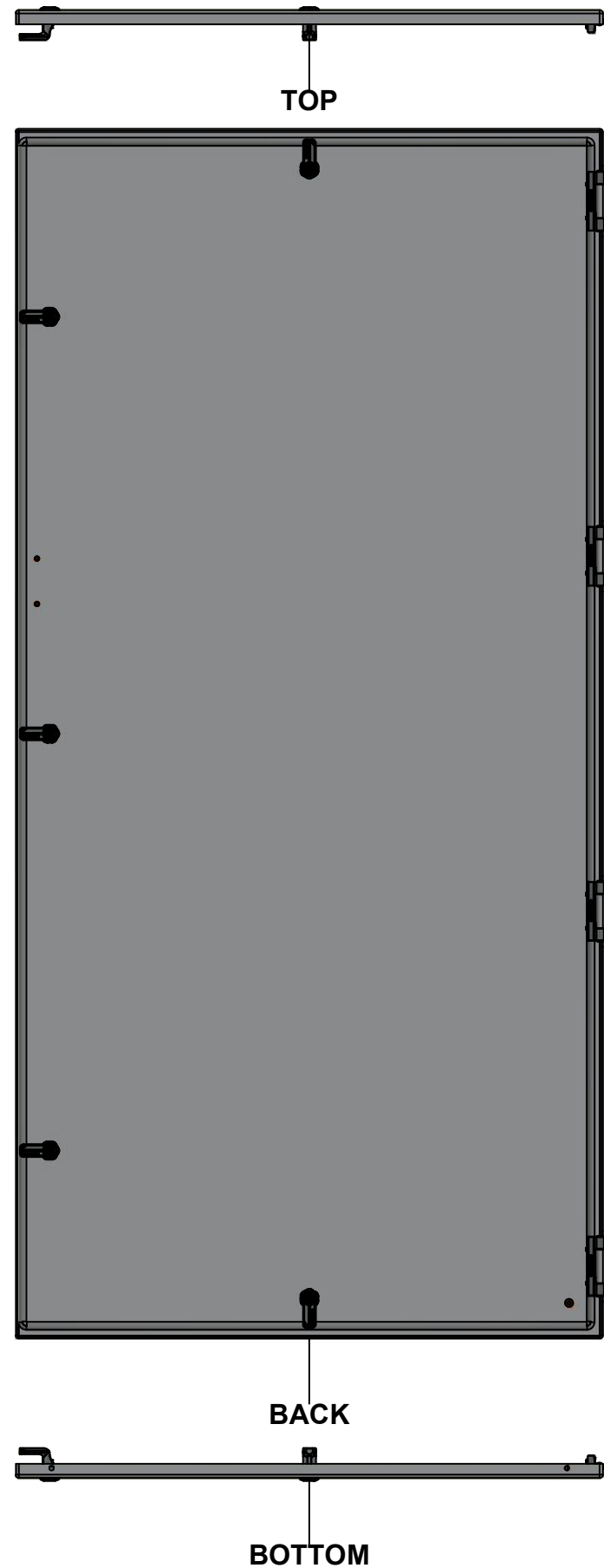

No.	Revisions	Date	By/Par

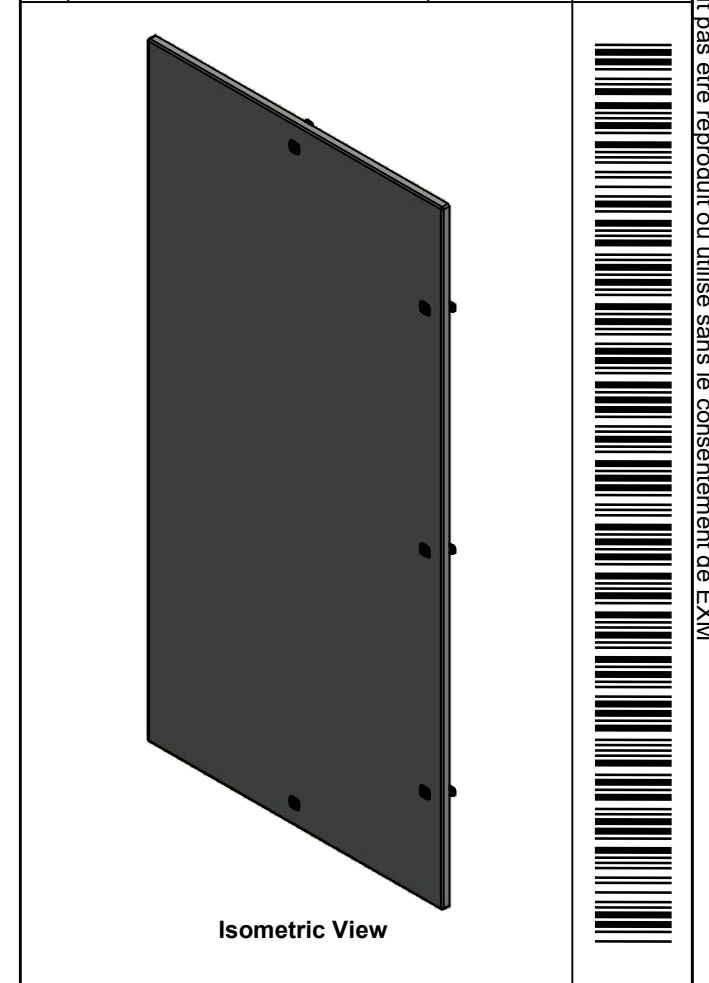

<p>Tél: (450) 979-4373 Fax: (450) 979-4626 www.exmweb.com</p>	Flatness Aplatissement	Max 3.0mm
	Projection	
Customer Client	Date	
Drawn By Dessiné Par	BoxCad: BoxCad	Date 2014-09-18
Material Matière	12 Ga Cold Rolled A1008 CS Type B (2.5mm)	
Color Couleur	Asa-61 Grey	Finish Fini Smooth
Description	Detail Rev.	
Part Number Numéro Pièce	5412DDS727212LD	Rev. 13
		0 18

SEE BILL OF MATERIAL ON LAST PAGE

This drawing is confidential and must not be reproduced or used without the consent of EXM

Ce dessin est confidentiel et ne doit pas être reproduit ou utilisé sans le consentement de EXM

STANDARD FEATURES ARE NOT LISTED IN THIS HOLE TABLE

HOLE TABLE - FRONT VIEW (CUSTOM FEATURE ONLY)

CUT-OUT	XDIM	YDIM	DESCRIPTION
1	2.000	2.118	GND STUD M6 x 16mm (Inside)
2	32.750	60.430	LOCK 889 SCQ4-SL @ 0.0°
3	32.750	35.774	LOCK 889 SCQ4-SL @ 0.0°
4	32.750	11.118	LOCK 889 SCQ4-SL @ 0.0°
5	17.375	69.180	LOCK 889 SCQ4-SL @ 90.0°
6	17.375	2.368	LOCK 889 SCQ4-SL @ 270.0°
7	33.489	43.445	STUDS M6 x 18mm (Inside)
8	33.489	46.123	STUDS M6 x 18mm (Inside)

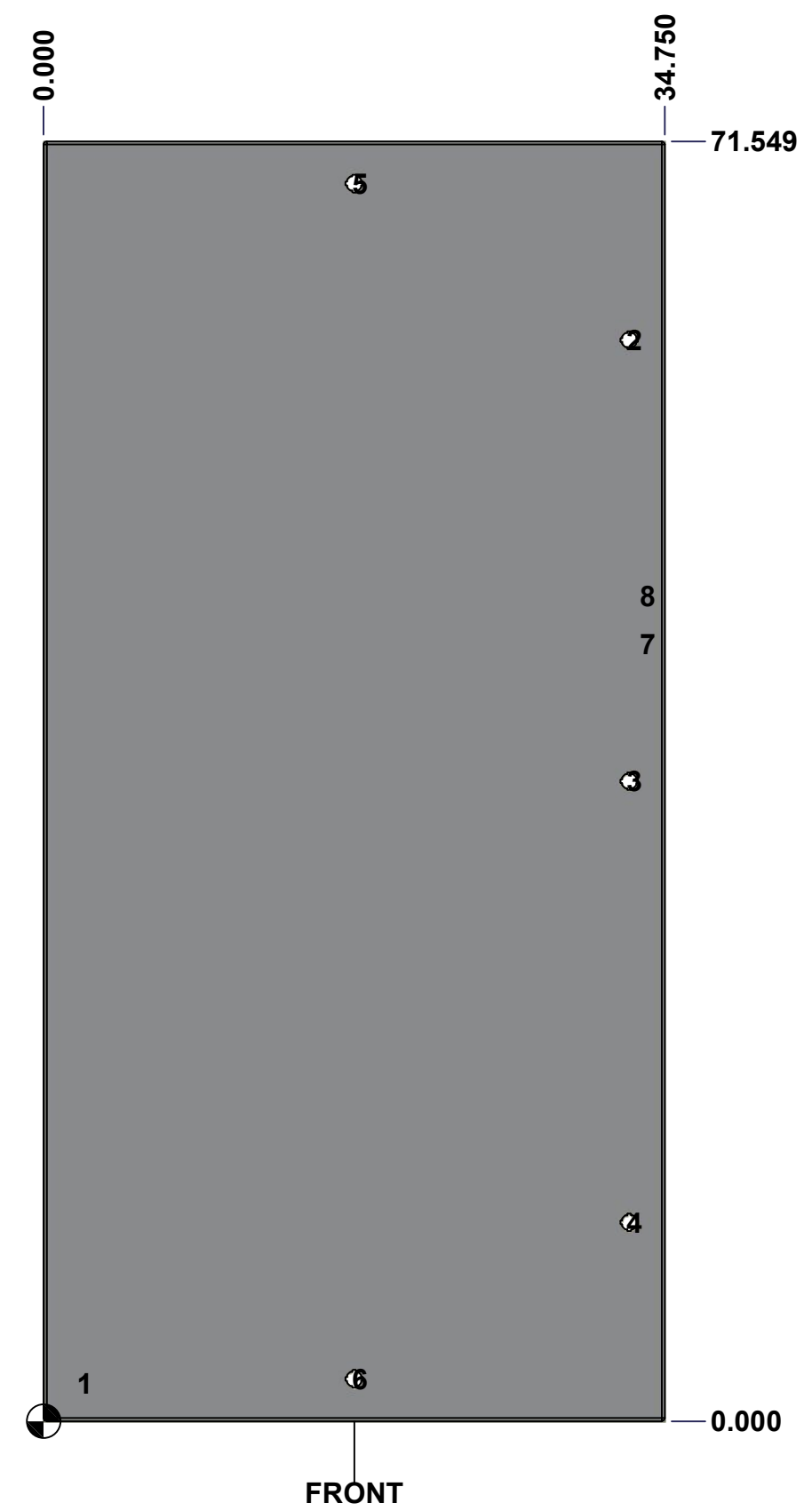

FRONT

	Description	Status	
	5412DDS 72" x 72" Slave Door	(NULL)	
	Part Number Numéro Pièce	Rev.	14
	5412DDS727212LD	0	18

This drawing is confidential and must not be reproduced or used without the consent of EXM

Ce dessin est confidentiel et ne doit pas être reproduit ou utilisé sans le consentement de EXM

No.	Revisions	Date	By/Par

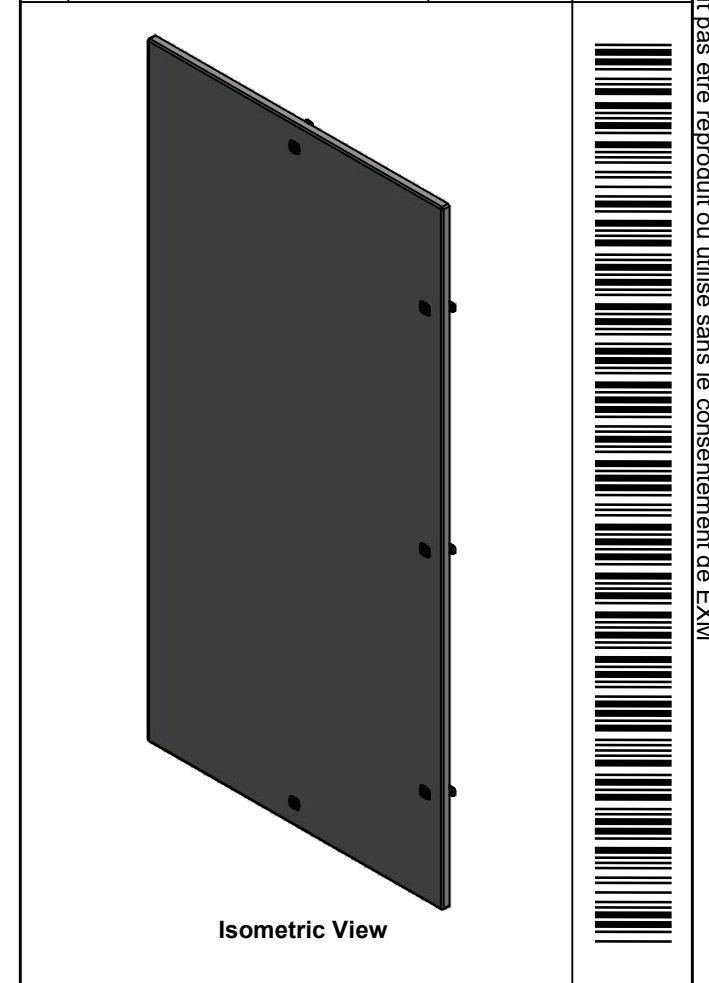

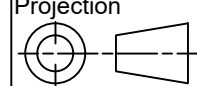
 Tél: (450) 979-4373 Fax: (450) 979-4626 www.exmweb.com		Flatness Aplatissement Max 3.0mm Projection 
Customer Client	Date	
Drawn By Dessiné Par	BoxCad: BoxCad	Date 2014-09-18
Material Matière	12 Ga Cold Rolled A1008 CS Type B (2.5mm)	
Color Couleur	Asa-61 Grey	Finish Fini Smooth
Description		Detail Rev.
5412DDS 72" x 72" Slave Door		
Part Number Numéro Pièce	Rev.	15
5412DDS727212LD	0	18

Qty	Part Name	Rev	Description
2	STK-Q-16055	1	M6 x 18mm Stud (No Paint Cap Required)
1	5412DDS727212DG	0	5412DDS 72" x 72" Door Gasket
1	STK-Q-16080	0	Ground Stud M6 x 16mm
1	STK-P-02400S	0	Powder Paint (Asa-61 Grey / Smooth)
1	5412DDS727212LD-P	0	5412DDS 72" x 72" Slave Door Part
4	STK-K-09860	7	Cabinet Hinge with Captive Pins
5	STK-K-12580	0	9412 1/4 Turn Lock
Parts List			

This drawing is confidential and must not be reproduced or used without the consent of EXM

Ce dessin est confidentiel et ne doit pas être reproduit ou utilisé sans le consentement de EXM

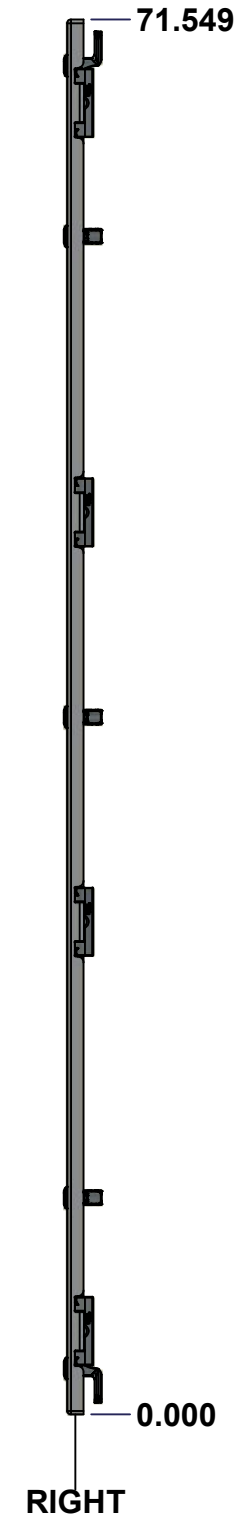
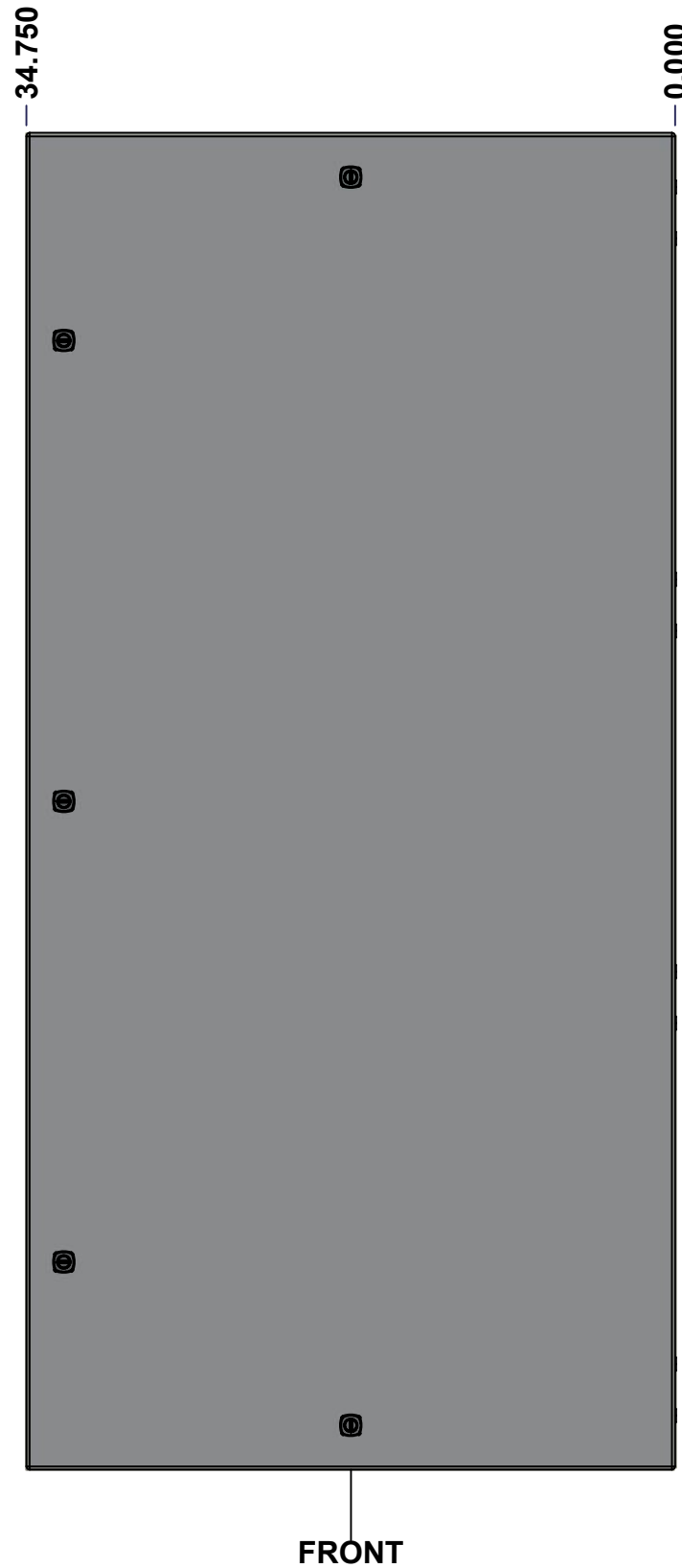
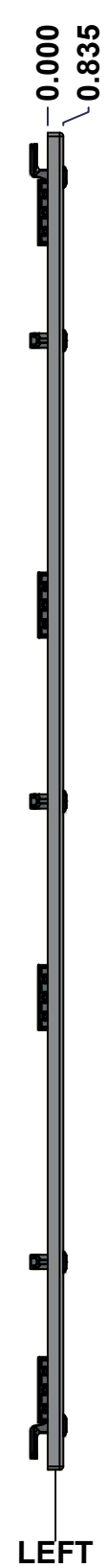
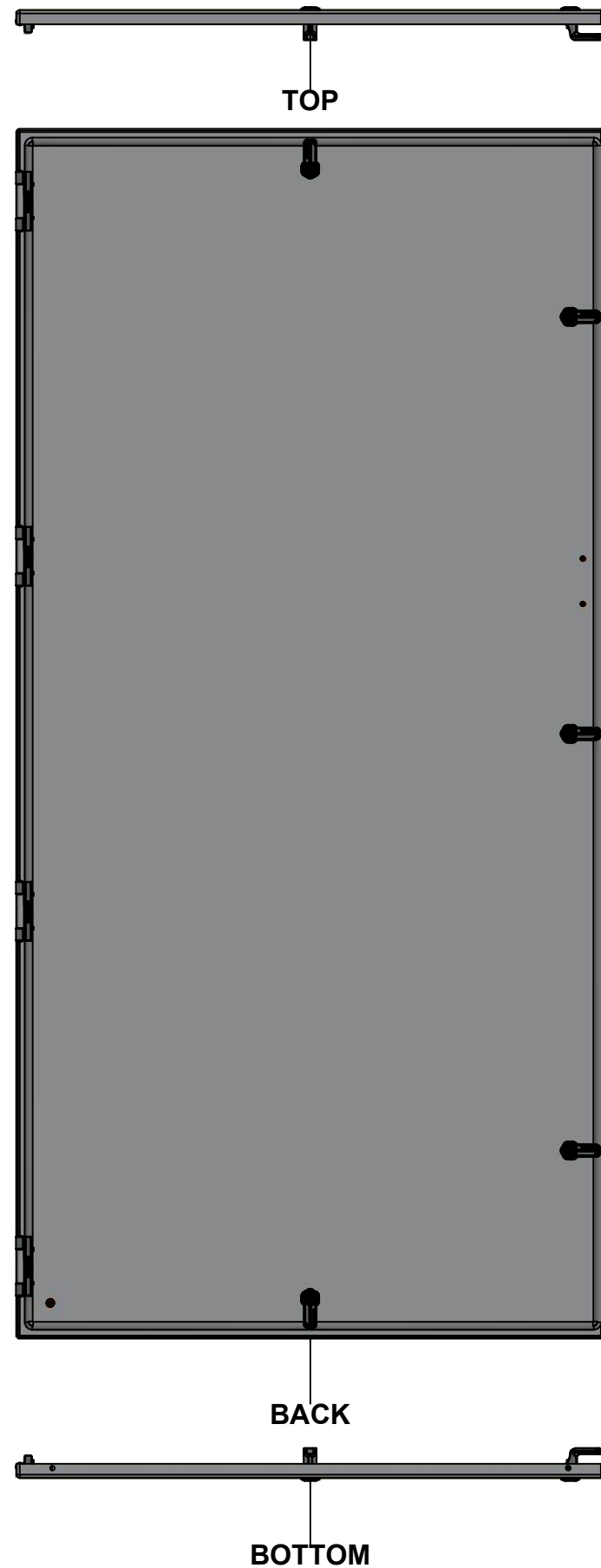

No.	Revisions	Date	By/Par

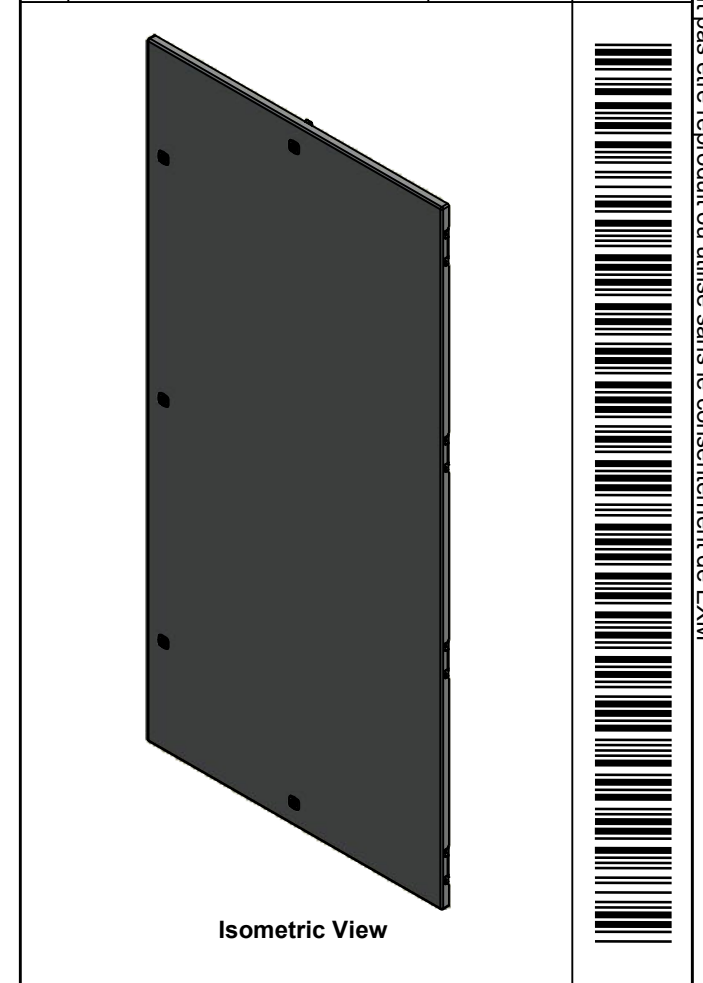

Tél: (450) 979-4373 Fax: (450) 979-4626 www.exmweb.com		Flatness Aplatissement	
		Max 3.0mm	
Customer Client		Date	
Drawn By Dessiné Par BoxCad: BoxCad		Date 2014-09-18	
Material Matière 12 Ga Cold Rolled A1008 CS Type B (2.5mm)			
Color Couleur Asa-61 Grey		Finish Fini Smooth	
Description 5412DDS 72" x 72" Master Door			Detail Rev.
Part Number Numéro Pièce 5412DDS727212FD		Rev. 0	16 / 18

SEE BILL OF MATERIAL ON LAST PAGE

This drawing is confidential and must not be reproduced or used without the consent of EXM

Ce dessin est confidentiel et ne doit pas être reproduit ou utilisé sans le consentement de EXM

STANDARD FEATURES ARE NOT LISTED IN THIS HOLE TABLE

HOLE TABLE - FRONT VIEW (CUSTOM FEATURE ONLY)

CUT-OUT	XDIM	YDIM	DESCRIPTION
1	2.000	2.118	GND STUD M6 x 16mm (Inside)
2	32.750	60.430	LOCK 889 SCQ4-SL @ 180.0°
3	32.750	35.774	LOCK 889 SCQ4-SL @ 180.0°
4	32.750	11.118	LOCK 889 SCQ4-SL @ 180.0°
5	17.375	69.180	LOCK 889 SCQ4-SL @ 90.0°
6	17.375	2.368	LOCK 889 SCQ4-SL @ 270.0°
7	33.489	43.445	STUDS M6 x 18mm (Inside)
8	33.489	46.123	STUDS M6 x 18mm (Inside)

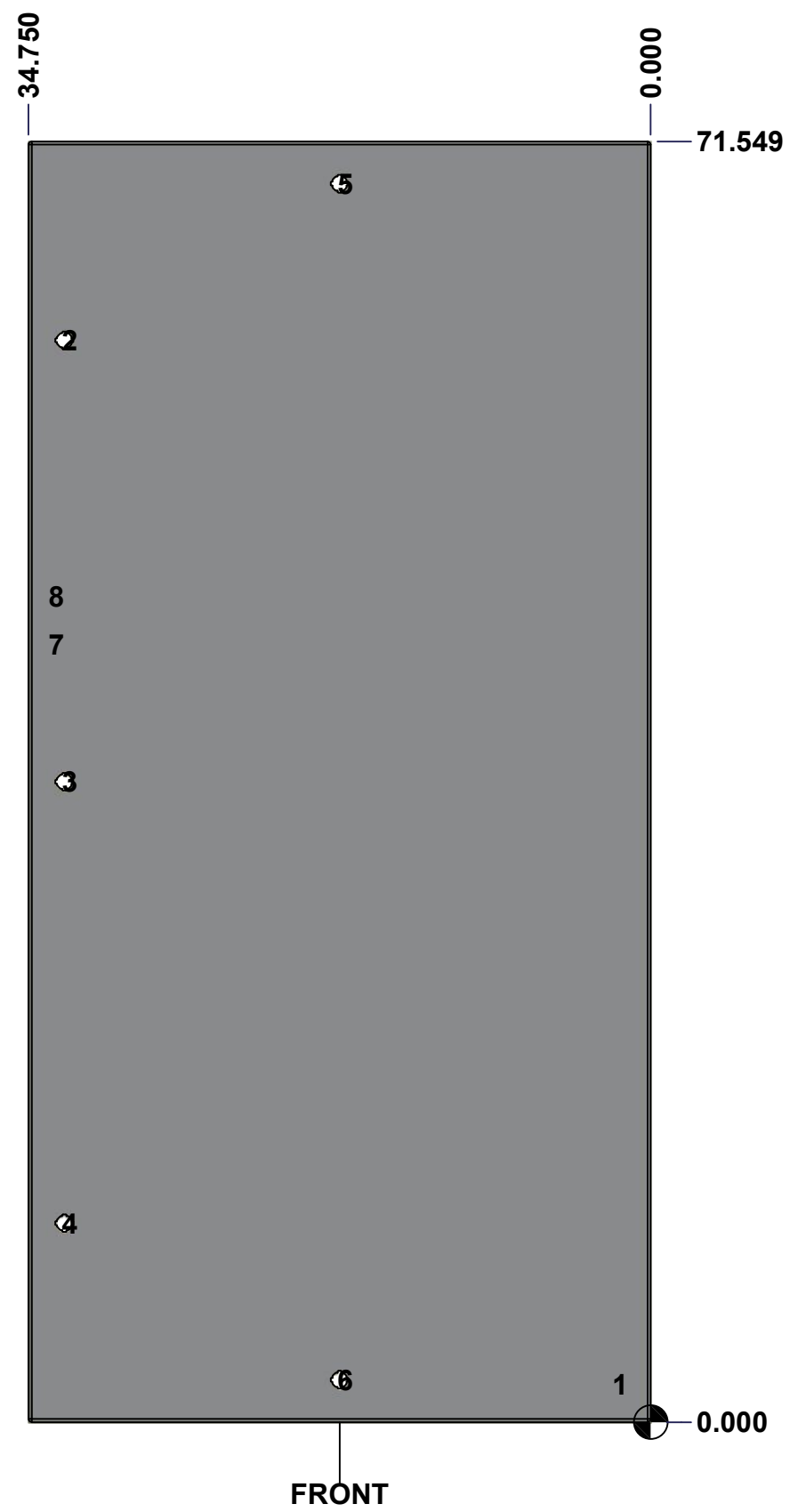

FRONT

	Description	Status
	5412DDS 72" x 72" Master Door	(NULL)
	Part Number Numéro Pièce	Rev.
	5412DDS727212FD	0 / 17
		18

This drawing is confidential and must not be reproduced or used without the consent of EXM

Ce dessin est confidentiel et ne doit pas être reproduit ou utilisé sans le consentement de EXM

No.	Revisions	Date	By/Par

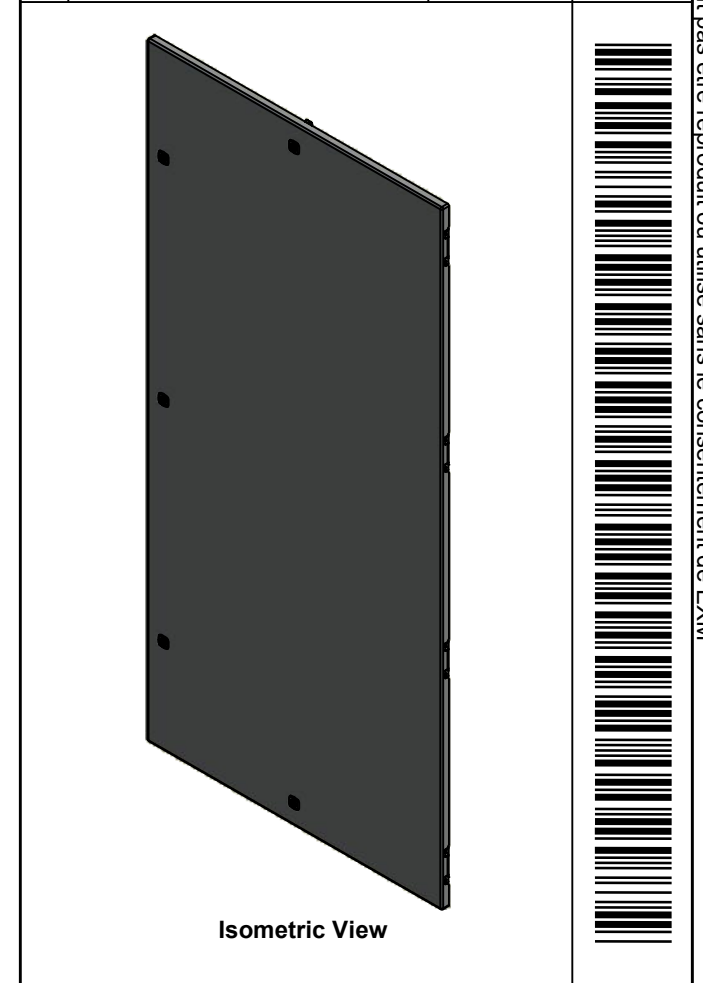

EXM
www.exmweb.com

Tél: (450) 979-4373
Fax: (450) 979-4626

Flatness
Aplatissement
Max 3.0mm

Projection

Customer Client _____ Date _____

Drawn By / Dessiné Par BoxCad: BoxCad Date 2014-09-18

Material / Matière 12 Ga Cold Rolled A1008 CS Type B (2.5mm)

Color / Couleur Asa-61 Grey Finish / Fini Smooth

Description 5412DDS 72" x 72" Master Door Detail Rev. _____

Part Number / Numéro Pièce **5412DDS727212FD** Rev. **0** 18

Qty	Part Name	Rev	Description
2	STK-Q-16055	1	M6 x 18mm Stud (No Paint Cap Required)
1	5412DDS727212DG	0	5412DDS 72" x 72" Door Gasket
1	STK-Q-16080	0	Ground Stud M6 x 16mm
1	STK-P-02400S	0	Powder Paint (Asa-61 Grey / Smooth)
1	5412DDS727212FD-P	0	5412DDS 72" x 72" Master Door Part
4	STK-K-09860	7	Cabinet Hinge with Captive Pins
5	STK-K-12580	0	9412 1/4 Turn Lock
Parts List			

This drawing is confidential and must not be reproduced or used without the consent of EXM

Ce dessin est confidentiel et ne doit pas être reproduit ou utilisé sans le consentement de EXM



TOP

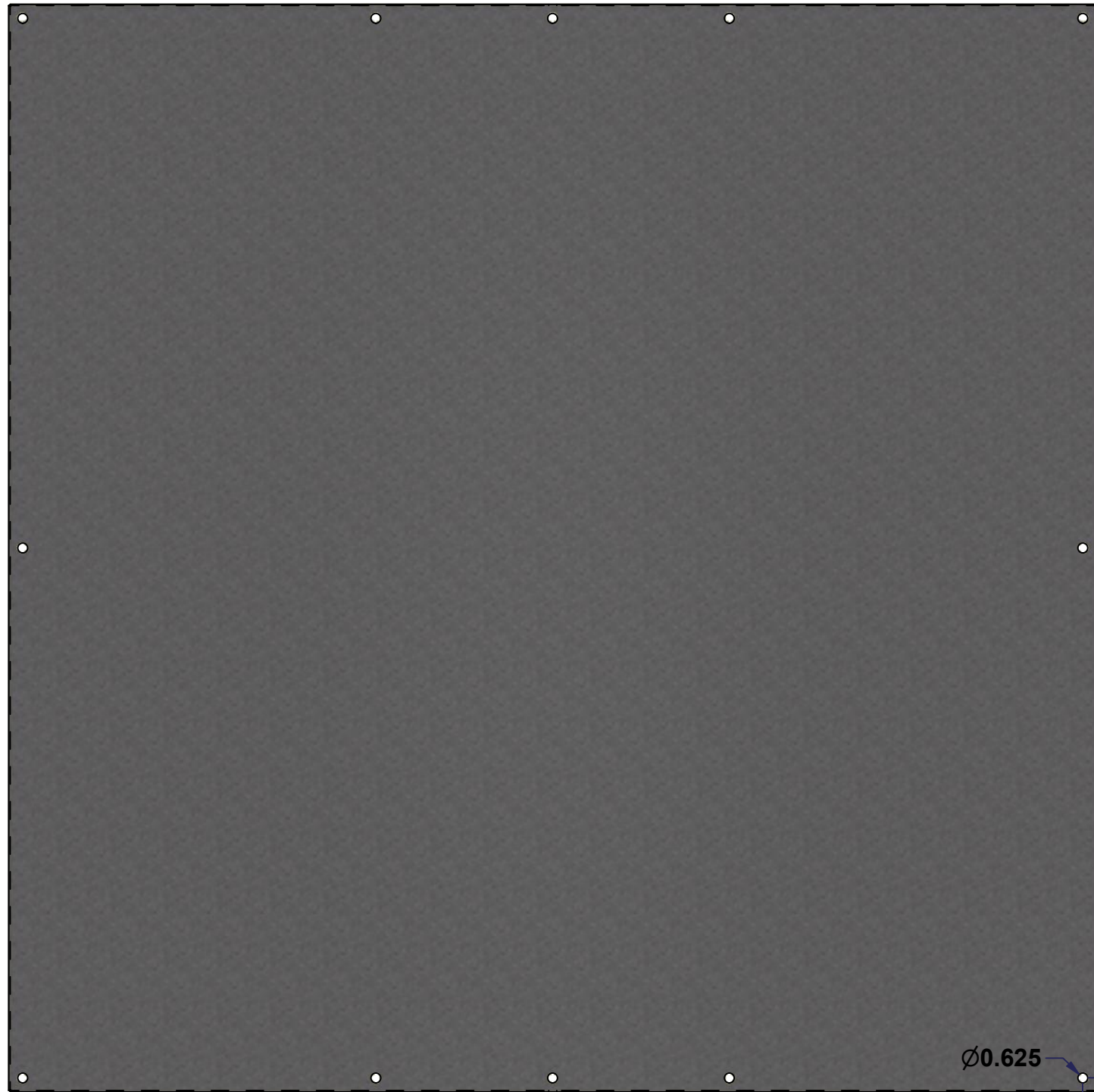

FRONT

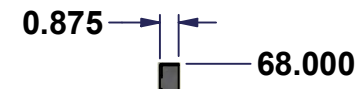

RIGHT

0.000

No.	Revisions	Date	By/Par

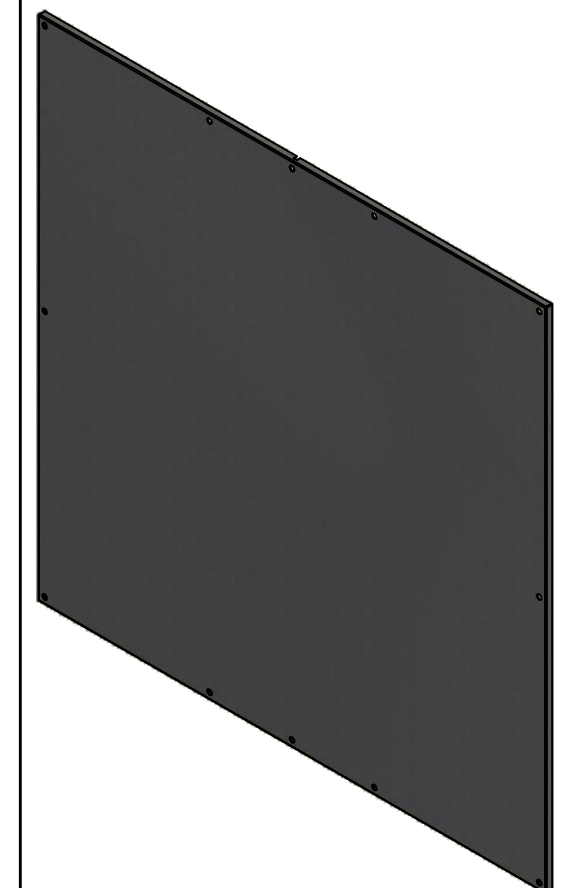

Isometric View



Tél: (450) 979-4373 Fax: (450) 979-4626 www.exmweb.com	Flatness Aplatissement	Max 3.0mm
	Projection	
Customer Client	Date	
Drawn By Dessiné Par	BoxCad	Date 04/11/2009
Material Matière	12 Ga Galvanized (2.5mm)	
Color Couleur	Unpainted	Finish Fini Unpainted
Description	Detail Rev.	
885 SP7272G Inner Panel		
Part Number Numéro Pièce	Rev.	1
885SP7272G	0	2

SEE BILL OF MATERIAL ON LAST PAGE

This drawing is confidential and must not be reproduced or used without the consent of EXM

Ce dessin est confidentiel et ne doit pas être reproduit ou utilisé sans le consentement de EXM

No.	Revisions	Date	By/Par

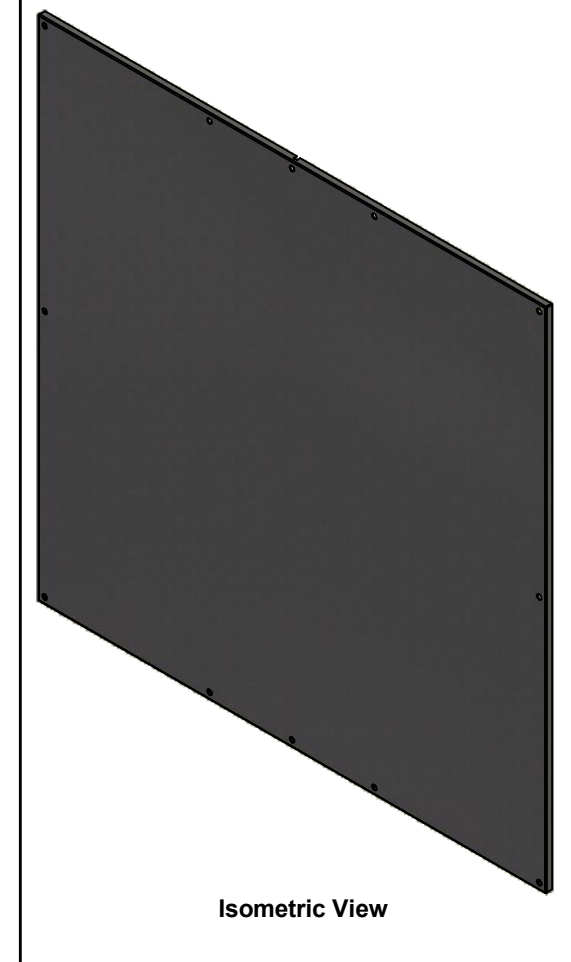

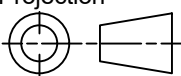
 Tél: (450) 979-4373 Fax: (450) 979-4626 www.exmweb.com		Flatness Aplatissement Max 3.0mm
Customer Client		Projection 
Drawn By / Dessiné Par: BoxCad		Date: 04/11/2009
Material / Matière: 12 Ga Galvanized (2.5mm)		
Color / Couleur: Unpainted	Finish / Fini: Unpainted	
Description: 885 SP7272G Inner Panel		Detail Rev.
Part Number / Numéro Pièce: 885SP7272G		Rev. 0 / 2

Qty	Part Number	Rev	Description
1	885SP7272G-P	0	885 SP7272G Inner Panel Part
Parts List			